



Edition

01/2024

EQUIPMENT MANUAL

SIMATIC

S7-1500R/H

CPU 1518HF-4 PN
6ES7518-4JP00-0AB0

support.industry.siemens.com

SIEMENS

SIMATIC

S7-1500R/H CPU 1518HF-4 PN (6ES7518-4JP00-0AB0)

Equipment Manual

Introduction

1

Industrial cybersecurity

2

Product overview

3

Connecting

4

Alarm, error and system
messages

5

Technical specifications

6

Dimension drawing

A



01/2024

A5E49868646-AC

Legal information

Warning notice system

This manual contains notices you have to observe in order to ensure your personal safety, as well as to prevent damage to property. The notices referring to your personal safety are highlighted in the manual by a safety alert symbol, notices referring only to property damage have no safety alert symbol. These notices shown below are graded according to the degree of danger.

 DANGER
indicates that death or severe personal injury will result if proper precautions are not taken.
 WARNING
indicates that death or severe personal injury may result if proper precautions are not taken.
 CAUTION
indicates that minor personal injury can result if proper precautions are not taken.
NOTICE
indicates that property damage can result if proper precautions are not taken.

If more than one degree of danger is present, the warning notice representing the highest degree of danger will be used. A notice warning of injury to persons with a safety alert symbol may also include a warning relating to property damage.

Qualified Personnel

The product/system described in this documentation may be operated only by **personnel qualified** for the specific task in accordance with the relevant documentation, in particular its warning notices and safety instructions. Qualified personnel are those who, based on their training and experience, are capable of identifying risks and avoiding potential hazards when working with these products/systems.

Proper use of Siemens products

Note the following:

 WARNING
Siemens products may only be used for the applications described in the catalog and in the relevant technical documentation. If products and components from other manufacturers are used, these must be recommended or approved by Siemens. Proper transport, storage, installation, assembly, commissioning, operation and maintenance are required to ensure that the products operate safely and without any problems. The permissible ambient conditions must be complied with. The information in the relevant documentation must be observed.

Trademarks

All names identified by ® are registered trademarks of Siemens Aktiengesellschaft. The remaining trademarks in this publication may be trademarks whose use by third parties for their own purposes could violate the rights of the owner.

Disclaimer of Liability

We have reviewed the contents of this publication to ensure consistency with the hardware and software described. Since variance cannot be precluded entirely, we cannot guarantee full consistency. However, the information in this publication is reviewed regularly and any necessary corrections are included in subsequent editions.

Table of contents

1	Introduction.....	5
1.1	S7-1500R/H Documentation Guide.....	6
1.1.1	Information classes S7-1500R/H.....	6
1.1.2	SIMATIC Technical Documentation.....	8
2	Industrial cybersecurity.....	10
2.1	Introduction to industrial cybersecurity.....	10
2.2	Cybersecurity information.....	10
2.3	Cybersecurity-relevant information.....	11
3	Product overview.....	13
3.1	New functions.....	13
3.2	Configuration and operating principle.....	16
3.3	Hardware properties.....	19
3.4	Firmware functions.....	21
3.5	Operator controls and display elements.....	24
3.5.1	Front view of the CPU with closed front flap.....	24
3.5.2	Front view of the CPU without front flaps.....	26
3.5.3	Rear view of the CPU.....	27
3.5.4	Bottom view.....	28
3.6	Mode selector.....	28
4	Connecting.....	30
4.1	Terminal assignment.....	30
5	Alarm, error and system messages.....	35
5.1	Status and error display of the CPU.....	35
6	Technical specifications.....	40
A	Dimension drawing.....	51

Introduction

Purpose of the documentation

This manual supplements the system manual of the S7-1500R/H redundant system and the function manuals. This manual contains a description of the module-specific information. The system-related functions are described in the system manual. All system-spanning functions are described in the function manuals.

The information provided in this manual and the system manual enables you to commission the CPU 1518HF-4 PN.

NOTE

When using CPU 1518HF-4 PN in Safety mode, note the description of the fail-safe system SIMATIC Safety SIMATIC Safety - Configuring and Programming (<https://support.industry.siemens.com/cs/ww/en/view/54110126>) programming and operating manual.

Conventions

STEP 7: In this documentation, "STEP 7" is used as a synonym for all versions of the configuration and programming software "STEP 7 (TIA Portal)".

Please also observe notes marked as follows:

NOTE

A note contains important information on the product described in the documentation, on the handling of the product or on the section of the documentation to which particular attention should be paid.

Recycling and disposal

For environmentally friendly recycling and disposal of your old equipment, contact a certified electronic waste disposal company and dispose of the equipment according to the applicable regulations in your country.

Industry Mall

The Industry Mall is the catalog and order system of Siemens AG for automation and drive solutions on the basis of Totally Integrated Automation (TIA) and Totally Integrated Power (TIP).

You can find catalogs for all automation and drive products on the Internet (<https://mall.industry.siemens.com>).

ID-Link for the digital nameplate



The ID-Link is a globally unique identifier according to IEC 61406-1, which you will find in the future as a QR code on your product.

The figure shows an example of an ID-Link for the CPU 1518HF-4 PN.

You can recognize the ID-Link by the frame with a black corner at the bottom right. The ID-Link takes you to the digital nameplate of your product.

Scan the QR code on the product or packaging label with a smartphone camera, barcode scanner, or reader app. Call the ID-Link.

In the digital nameplate, you will find product data, manuals, declarations of conformity, certificates, and other helpful information about your product.

1.1 S7-1500R/H Documentation Guide

1.1.1 Information classes S7-1500R/H



The documentation for the redundant S7-1500R/H system is arranged into three areas. This arrangement enables you to access the specific content you require. You can download the documentation free of charge from the Internet (<https://support.industry.siemens.com/cs/ww/en/view/109742691>).

Basic information



The System Manual and Getting Started describe in detail the configuration, installation, wiring and commissioning of the redundant S7-1500R/H system.

The STEP 7 online help supports you in the configuration and programming.

Examples:

- Getting Started S7-1500R/H
- System manual S7-1500R/H
- Online help TIA Portal

Device information



Equipment manuals contain a compact description of the module-specific information, such as properties, wiring diagrams, characteristics and technical specifications.

Examples:

- Equipment Manuals CPUs
- Equipment Manuals Power Supply Modules

General information



The function manuals contain detailed descriptions on general topics relating to the redundant S7-1500R/H system.

Examples:

- Function Manual Diagnostics
- Function Manual Communication
- Function manual Structure and Use of the CPU Memory
- Function Manual Cycle and Response Times
- PROFINET Function Manual

Product Information

Changes and supplements to the manuals are documented in a Product Information. The Product Information takes precedence over the device and system manuals.

You can find the latest Product Information on the redundant S7-1500R/H system on the Internet. (<https://support.industry.siemens.com/cs/ww/en/view/109742691>)

Manual Collection S7-1500/ET 200MP

The Manual Collection S7-1500/ET 200MP contains the complete documentation on the redundant S7-1500R/H system gathered together in one file.

You can find the Manual Collection on the Internet.

(<https://support.industry.siemens.com/cs/ww/en/view/86140384>)

SIMATIC S7-1500 comparison list for programming languages

The comparison list contains an overview of which instructions and functions you can use for which controller families.

You can find the comparison list on the Internet.

(<https://support.industry.siemens.com/cs/ww/en/view/86630375>)

1.1.2 SIMATIC Technical Documentation

Additional SIMATIC documents will complete your information. You can find these documents and their use at the following links and QR codes.

The Industry Online Support gives you the option to get information on all topics. Application examples support you in solving your automation tasks.

Overview of the SIMATIC Technical Documentation

Here you will find an overview of the SIMATIC documentation available in Siemens Industry Online Support:



Industry Online Support International

<https://support.industry.siemens.com/cs/ww/en/view/109742705>

Watch this short video to find out where you can find the overview directly in Siemens Industry Online Support and how to use Siemens Industry Online Support on your mobile device:



Quick introduction to the technical documentation of automation products per video <https://support.industry.siemens.com/cs/us/en/view/109780491>



YouTube video: Siemens Automation Products - Technical Documentation at a Glance <https://youtu.be/TwLSxxRQqSA>

Retention of the documentation

Retain the documentation for later use.

For documentation provided in digital form:

1. Download the associated documentation after receiving your product and before initial installation/commissioning. Use the following download options:
 - Industry Online Support International: <https://support.industry.siemens.com>
The article number is used to assign the documentation to the product. The article number is specified on the product and on the packaging label. Products with new, non-compatible functions are provided with a new article number and documentation.
 - ID link:
Your product may have an ID link. The ID link is a QR code with a frame and a black frame corner at the bottom right. The ID link takes you to the digital nameplate of your product. Scan the QR code on the product or on the packaging label with a smartphone camera, barcode scanner, or reader app. Call up the ID link.
2. Retain this version of the documentation.

Updating the documentation

The documentation of the product is updated in digital form. In particular in the case of function extensions, the new performance features are provided in an updated version.

1. Download the current version as described above via the Industry Online Support or the ID link.
2. Also retain this version of the documentation.

mySupport

With "mySupport" you can get the most out of your Industry Online Support.

Registration	You must register once to use the full functionality of "mySupport". After registration, you can create filters, favorites and tabs in your personal workspace.
Support requests	Your data is already filled out in support requests, and you can get an overview of your current requests at any time.
Documentation	In the Documentation area you can build your personal library.
Favorites	You can use the "Add to mySupport favorites" to flag especially interesting or frequently needed content. Under "Favorites", you will find a list of your flagged entries.
Recently viewed articles	The most recently viewed pages in mySupport are available under "Recently viewed articles".
CAX data	The CAX data area gives you access to the latest product data for your CAX or CAe system. You configure your own download package with a few clicks: <ul style="list-style-type: none"> • Product images, 2D dimension drawings, 3D models, internal circuit diagrams, EPLAN macro files • Manuals, characteristics, operating manuals, certificates • Product master data

You can find "mySupport" on the Internet. (<https://support.industry.siemens.com/My/ww/en>)

Application examples

The application examples support you with various tools and examples for solving your automation tasks. Solutions are shown in interplay with multiple components in the system - separated from the focus on individual products.

You can find the application examples on the Internet.
(<https://support.industry.siemens.com/cs/ww/en/ps/ae>)

Industrial cybersecurity

2.1 Introduction to industrial cybersecurity

Due to the digitalization and increasing networking of machines and industrial plants, the risk of cyber attacks is also growing. Appropriate protective measures are therefore mandatory, particularly in the case of critical infrastructure facilities.

Refer to the System Manual (<https://support.industry.siemens.com/cs/us/en/view/109754833>) for general information and measures regarding industrial cybersecurity.

This section provides an overview of security-related information pertaining to your SIMATIC device.

NOTE

Security-relevant changes to software or devices are documented in the section "New functions ([Page 13](#))".

2.2 Cybersecurity information

Siemens provides products and solutions with industrial cybersecurity functions that support the secure operation of plants, systems, machines, and networks.

In order to protect plants, systems, machines, and networks against cyber threats, it is necessary to implement – and continuously maintain – a holistic, state-of-the-art industrial cybersecurity concept. Siemens' products and solutions constitute one element of such a concept.

Customers are responsible for preventing unauthorized access to their plants, systems, machines and networks. Such systems, machines and components should only be connected to an enterprise network or the internet if and to the extent such a connection is necessary and only when appropriate security measures (e.g. firewalls and/or network segmentation) are in place.

For more information on protective industrial cybersecurity measures for implementation, please visit (<https://www.siemens.com/global/en/products/automation/topic-areas/industrial-cybersecurity.html>).

Siemens' products and solutions undergo continuous development to make them more secure. Siemens strongly recommends that product updates are applied as soon as they are available and that the latest product versions are used. Use of product versions that are no longer supported, and failure to apply the latest updates may increase customers' exposure to cyber threats.

To stay informed about product updates at all times, subscribe to the Siemens Industrial Cybersecurity RSS Feed under (<https://new.siemens.com/global/en/products/services/cert.html>).

2.3 Cybersecurity-relevant information

Note all cybersecurity-relevant information.

Topics with cybersecurity-relevant information	Reference
Operational application environment and security assumptions	
Requirements for the operational application environment of the system and security assumptions	This section is found in the System Manual (https://support.industry.siemens.com/cs/us/en/view/109754833).
Security properties of the product	
<p>Access protection</p> <p>Physical protection:</p> <ul style="list-style-type: none"> You can protect the CPU against unauthorized access by locking the front flap. <p>Password protection</p> <p>You can also protect the CPU with a password.</p> <p>Password categories:</p> <ul style="list-style-type: none"> Password to protect confidential configuration data Password in the context of user management (UMAC) Password for display 	<p>Information on locking and on password protection can be found in this Equipment Manual in the section Operator controls and display elements (Page 24).</p> <p>Also note the information on the topic of access protection in the Protection section of the System Manual (https://support.industry.siemens.com/cs/us/en/view/109754833).</p>
<p>Integrated protection functions</p> <ul style="list-style-type: none"> The CPUs have integrated protection functions. 	<p>For information on the protection functions, refer to the "Overview of protection functions" section of the System Manual (https://support.industry.siemens.com/cs/us/en/view/109754833).</p>
<p>PROFINET Security Class 1</p> <ul style="list-style-type: none"> The device supports PROFINET Security Class 1. With the introduction of PROFINET Security Class 1, additional security settings have been integrated into the PROFINET communication. 	<p>Detailed information about PROFINET Security Class 1 and the additional security settings can be found in the PROFINET with STEP 7 Function Manual (https://support.industry.siemens.com/cs/us/en/view/49948856).</p>
Reading out and verifying signatures	You can find detailed information on reading and verifying signatures in the STEP 7 online help (TIA Portal).
Supported Ethernet services	<p>Information about supported services can be found in the section Technical specifications (Page 40).</p> <p>You can find detailed information on the supported Ethernet services in the Communication Function Manual (https://support.industry.siemens.com/cs/us/en/view/59192925).</p>
Interfaces, ports, protocols and services	
<p>Information on the following is security related:</p> <ul style="list-style-type: none"> Communications layer and communication role Default states Enabling/disabling ports and services 	<p>You can find detailed information on these topics in the Communication Function Manual (https://support.industry.siemens.com/cs/us/en/view/59192925).</p>
Secure operation	
Corrective measures for known risks	<p>Corrective measures for known risks are announced on the Siemens ProductCERT (https://siemens.com/productcert) Web page.</p> <p>For more information on SIEMENS ProductCERT, refer to the System Manual (https://support.industry.siemens.com/cs/us/en/view/109754833).</p>

2.3 Cybersecurity-relevant information

Topics with cybersecurity-relevant information	Reference
Security checks	Application-specific security measures such as cyclic checks of the configuration via checksums are described in the System Manual https://support.industry.siemens.com/cs/us/en/view/109754833 .
Recording Security events	Information on recording security events can be found in the "Safe operation of CPUs" section of the System Manual https://support.industry.siemens.com/cs/us/en/view/109754833 .
Secure decommissioning Products that contain security-relevant data must be securely decommissioned before disposal or resale.	Information on secure decommissioning can be found in the "Safe operation of the system" section of the System Manual https://support.industry.siemens.com/cs/us/en/view/109754833 .

Product overview

3.1 New functions

This section contains an overview of the most important new firmware functions of the CPU compared with the predecessor version CPU (V3.0).

New functions of the CPU in firmware version V3.1

New functions	Customer benefits	Where can I find information?
Power supply modules	<p>System power supplies (PS) supply the internal electronics of the S7-1500R/H modules with power via the backplane bus. The following system power supply modules are supported:</p> <ul style="list-style-type: none"> • PS 25W 24V DC • PS 60W 24/48/60V DC • PS 60W 120/230V AC/DC <p>The redundant design of system power supply modules in the H-CPU increases the availability of the supply voltage. If a PS (or supply voltage) fails, the H-CPU (with the central CPs) remains in the RUN-Redundant operating state.</p>	<p>S7-1500R/H System Manual https://support.industry.siemens.com/cs/ww/en/view/109754833</p>
Communications processors CPs	<p>The CPs relieve the R/H CPUs from communication tasks and enable further communication connections:</p> <ul style="list-style-type: none"> • To the automation level • To the IT world <p>The redundant design of the CPs (per R/H CPU) increases the availability of the redundant system for communication tasks. From FW version V3.1 the S7-1500R/H redundant system supports the CP 1543-1 communications processor:</p> <ul style="list-style-type: none"> • S7-1500H: max. 6 CPs per H-CPU 	<ul style="list-style-type: none"> • S7-1500R/H System Manual https://support.industry.siemens.com/cs/ww/en/view/109754833 • CP 1543-1 https://support.industry.siemens.com/cs/de/de/view/67700710/en operating instructions
Active backplane bus	<p>The active backplane bus provides you with the following advantages with the S7-1500H redundant system:</p> <ul style="list-style-type: none"> • Pulling or plugging of CP 1543-1 communications processors in the RUN-Redundant system state. • Module reserves (CP 1543-1) can be kept ready for later use. <p>The active backplane bus can be used with the H-CPU as of firmware version V3.1. You can find more information on the active backplane bus (e.g. installing, config-</p>	<p>Active backplane bus https://support.industry.siemens.com/cs/de/de/view/109778694/en Equipment Manual</p>

3.1 New functions

New functions	Customer benefits	Where can I find information?
	<p>uring, technical specifications) in the Active backplane bus Equipment Manual. The active backplane bus can be ordered as an accessory/spare part.</p>	
IE/PB LINK HA	<p>The IE/PB LINK HA connects PROFINET IO and PROFIBUS DP as a gateway. This enables the IE/PB LINK HA to access all DP devices connected to the lower-level PROFIBUS network.</p> <p>The IE/PB LINK HA supports up to 64 DP devices.</p> <p>In the redundant S7-1500R/H system, the IE/PB LINK HA is integrated into the PROFINET network as an S2 device.</p>	<ul style="list-style-type: none"> • S7-1500R/H System Manual (https://support.industry.siemens.com/cs/ww/en/view/1097548-33) • IE/PB LINK (https://support.industry.siemens.com/cs/de/de/view/10974428-0/en) operating instructions
Web API of the Web server (Application Programming Interface)	<p>As of firmware version V3.1, the S7-1500R/H redundant system supports the Web API of the Web server. An overview of which mechanisms and methods support the R/H CPUs can be found in the Web server Function Manual.</p>	<p>Web server (https://support.industry.siemens.com/cs/de/en/view/59193560) Function Manual</p>
Data exchange via OPC UA as server	<p>As of firmware version V3.1, the S7-1500R/H redundant system supports data exchange as an OPC UA server. An OPC UA server provides information within a network, e.g. relating to the CPU, the OPC UA server itself, the data, and the data types. An OPC UA client accesses this information.</p>	<ul style="list-style-type: none"> • S7-1500R/H System Manual (https://support.industry.siemens.com/cs/ww/en/view/1097548-33) • Communication (https://support.industry.siemens.com/cs/ww/en/view/5919292-5) Function Manual
Data logging	<p>As of firmware version V3.1 the S7-1500R/H redundant system supports data logging.</p> <p>With data logging, you can save process values from the user program in a file known as the data log. The data logs are saved on the SIMATIC Memory Card in CSV format and stored in the "DataLogs" directory.</p> <p>You can create and modify data logs using the asynchronous "data logging" instructions. Data logs from the S7-1500R/H are loaded via the Web API of the Web server.</p>	<p>Structure and use of the CPU memory (https://support.industry.siemens.com/cs/ww/en/view/59193101) Function Manual</p>
User files	<p>As of firmware version V3.1, the S7-1500R/H redundant system supports user files.</p> <p>User files are user-specific files that are stored on the SIMATIC Memory Card and in the "UserFiles" directory.</p> <p>You can read and write user files via the asynchronous "File handling" instructions (FileReadC, FileWriteC) or via the Web API of the Web server.</p>	<p>STEP 7 online help</p>

New functions	Customer benefits	Where can I find information?
Additional new functions	You can find an overview in the System Manual.	S7-1500R/H System Manual (https://support.industry.siemens.com/cs/ww/en/view/109754833)

New functions of the CPU in firmware version V3.0

New functions	Customer benefits	Where can I find information?
Support PROFINET system redundancy R1	As of FW version V3.0, the S7-1500H redundant system supports PROFINET system redundancy R1: <ul style="list-style-type: none"> ET 200SP IM 155-6 PN R1 (6ES7155-6AU00-0HM0) ET 200SP HA IM 155-6 PN HA (6DL1155-6AU00-0PM0) ET 200iSP IM 152-1 PN (6ES7152-1BA00-0AB0) R1 devices are equipped with two interface modules compared to S2 devices. If one interface module fails, the R1 device can still be reached by the H-CPU via the second interface module. Thus, R1 devices have a higher availability than S2 devices.	<ul style="list-style-type: none"> S7-1500R/H System Manual (https://support.industry.siemens.com/cs/ww/en/view/109754833) PROFINET Function Manual (http://support.automation.siemens.com/WW/view/en/49948856)
New configuration variants for S7-1500H	As of FW version V3.0, the S7-1500H redundant system supports additional configuration variants: <ul style="list-style-type: none"> Configuration of PROFINET rings with R1 devices Configuration of a line topology with S2 devices, switched S1 devices Configuration of a line topology with R1 devices Configuration of a combined topology with R1 devices, S2 devices Configuration without additional devices This allows you to connect the S7-1500H redundant system to almost any network topology and solve complex automation tasks.	S7-1500R/H System Manual (https://support.industry.siemens.com/cs/ww/en/view/109754833)
OB 70	As of FW version V3.0, OB 70 (I/O redundancy error) is available for the diagnostics of R1 and S2 devices in S7-1500H systems.	S7-1500R/H System Manual (https://support.industry.siemens.com/cs/ww/en/view/109754833)
Synchronization module up to 40 km	As of FW version V3.0, a new synchronization module Sync Module 1 GB FO 40 km is available. The synchronization module enables a distance of up to 40 km between the two H-CPU via optical fibers. This allows you to use the S7-1500H redundant system for long tunnel installations.	S7-1500R/H System Manual (https://support.industry.siemens.com/cs/ww/en/view/109754833)

3.2 Configuration and operating principle

New functions	Customer benefits	Where can I find information?
Data block functions	As of FW version V3.0, the instructions for the data block functions are supported: <ul style="list-style-type: none"> • CREATE_DB (create data block) • READ_DBL (read from data block in the load memory) • WRIT_DBL (write to data block in load memory) • DELETE_DB (delete data block) 	STEP 7 online help
Network management protocol SNMP: A simple configuration option is now available for using SNMP services. For new configurations, this is disabled by default in accordance with "Security-by-Default".	Can be enabled/disabled in the CPU properties. Community strings can be configured.	Communication Function Manual (https://support.industry.siemens.com/cs/ww/en/view/59192925)
Trace: The S7-1500 CPU supports up to 64 configured signals per trace.	Number of configurable signals per trace extended	Using the Trace and Logic Analyzer Function Function Manual (http://support.automation.siemens.com/WW/view/en/64897128)

Additional information

You can find an overview of all new functions, improvements and revisions in the respective firmware version on the Internet

(<https://support.industry.siemens.com/cs/ww/en/view/109478459>).

3.2 Configuration and operating principle

Structure

The S7-1500H redundant system consists of the following components:

- Two CPUs of the type CPU 1518HF-4 PN
- Two SIMATIC Memory Cards
- Four synchronization modules (two synchronization modules in each H-CPU)
- Two redundancy connections (two duplex fiber-optic cables)
- IO devices
- Optional load current supply
- Optional system power supply (only via active backplane bus)
- Optional CP 1543-1 communications processors (only via active backplane bus)

You mount the CPUs on a common mounting rail or spatially separated on two separate mounting rails. You connect the two CPUs with fiber-optic cables to two synchronization modules in each CPU.

You set up the PROFINET ring or the PROFINET network via the PROFINET interfaces X1 P1R and X1 P2R of the CPUs (as of FW version V3.0: e.g. as line or mixed topology).

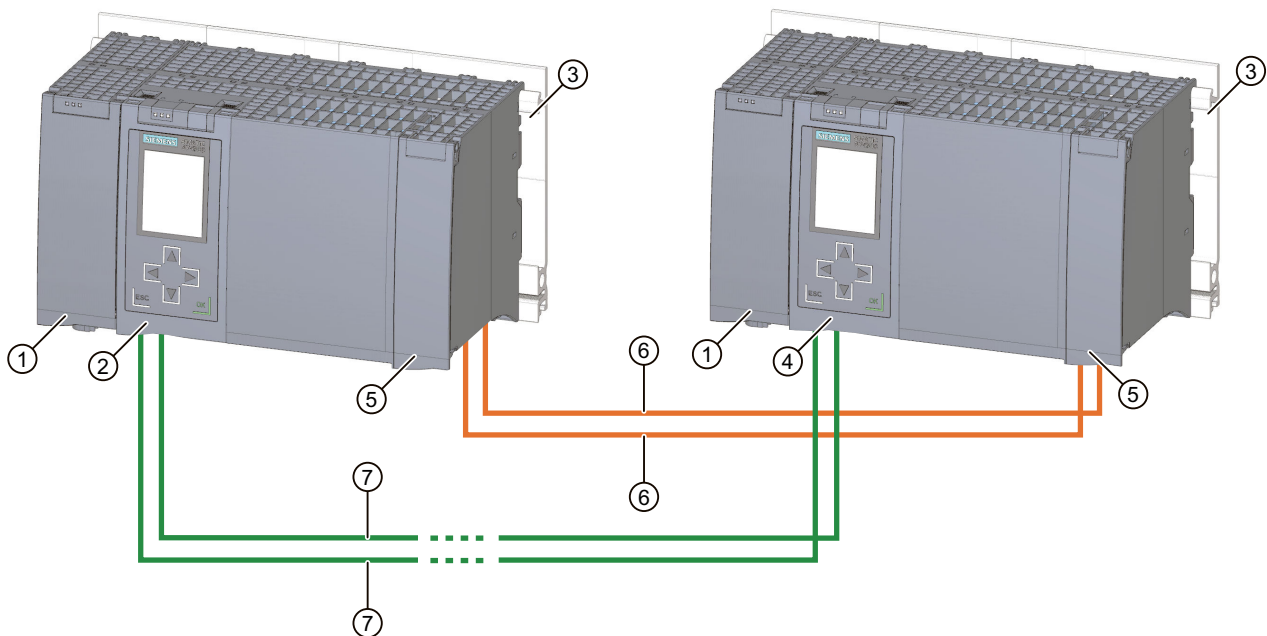

- ① Optional load current supply
- ② First CPU
- ③ Mounting rail with integrated DIN rail profile
- ④ Second CPU
- ⑤ Location of the synchronization modules (not visible in graphic)
- ⑥ Redundancy connections (fiber-optic cables)
- ⑦ PROFINET cable (PROFINET ring)

Figure 3-1 S7-1500H configuration example (with PROFINET ring)

NOTE

Standard rail adapter

You mount the CPUs on a standardized 35 mm rail using the standard rail adapter.

You can find information on mounting the DIN-rail adapter in the S7-1500R/H redundant system System Manual.

Principle of operation

One of the two CPUs in the redundant system takes on the role of CPU for process control (primary CPU). The other CPU takes on the role of the following CPU (backup CPU). The role of the CPUs can change during operation. All relevant data is synchronized from the primary CPU to the backup CPU via the fiber-optic cables of the redundancy connections.

Synchronization between the primary CPU and backup CPU ensures fast switching between CPUs in the event of a primary CPU failure. If the primary CPU fails, the backup CPU retains control of the process as the new primary CPU at the point of interruption.

The redundancy connections consist of two fiber-optic cables, which directly connect the CPUs via plug-in synchronization modules.

The integrated F functionality with Safety Integrated processes standard and safety programs.

You can find more information in the SIMATIC Safety - Configuring and Programming (<https://support.industry.siemens.com/cs/ww/en/view/54110126>) Programming and Operating Manual.

Additional information

You can find a detailed description of the operation and design of the S7-1500H redundant system in the S7-1500R/H redundant system System Manual.

See also

Redundant System S7-1500R/H System Manual

(<https://support.industry.siemens.com/cs/ww/en/view/109754833>)

3.3 Hardware properties

Article number

6ES7518-4JP00-0AB0

View of the module

The figure below shows CPU 1518HF-4 PN.



Figure 3-2 CPU 1518HF-4 PN

NOTE

Protective film

Note that there is a removable protective film on the display when the CPUs are delivered.

Properties

CPU 1518HF-4 PN has the following technical properties:

Property	Description	Additional information
CPU display	All CPUs of the redundant system S7 1500R/H have a display with plain text information. The display provides you with diagnostic messages as well as information about the article number, the firmware version and the serial number of the CPU. You can also view and assign the IP addresses, the PROFINET device name and the redundancy ID of the	<ul style="list-style-type: none"> Redundant System S7-1500R/H (https://support.industry.siemens.com/cs/ww/en/view/109754833) System Manual

3.3 Hardware properties

Property	Description	Additional information
	CPU. The system IP address can be viewed via STEP 7 but not in the display. In addition to the functions listed here, a large number of other functions are available on the display. These additional functions are described in the SIMATIC S7 1500 Display Simulator.	<ul style="list-style-type: none"> SIMATIC S7-1500 Display Simulator (https://support.industry.siemens.com/cs/ww/en/view/109761758)
Supply voltage	The 24 V DC supply voltage is fed via a 4-pin plug located on the front of the CPU.	<ul style="list-style-type: none"> Section Connecting (Page 30) Redundant System S7-1500R/H (https://support.industry.siemens.com/cs/ww/en/view/109754833) System Manual
PROFINET IO		
PROFINET IO interface (X1 P1R and X1 P2R)	<p>The CPU has an X1 interface with two ports (X1 P1R and X1 P2R).</p> <ul style="list-style-type: none"> The PROFINET IO interface X1 (default P1R) is used to set up the PROFINET ring or PROFINET network (e.g. line topology, mixed topology) with the two CPUs and the IO devices. The interface supports PROFINET IO RT (Real-Time) and PROFINET basic functionality. Basic PROFINET functionality comprises: <ul style="list-style-type: none"> HMI communication Communication with the configuration system Communication with a higher-level network (backbone, router, Internet) Communication with another machine or automation cell 	<ul style="list-style-type: none"> Redundant System S7-1500R/H (https://support.industry.siemens.com/cs/ww/en/view/109754833) System Manual PROFINET Function Manual (https://support.industry.siemens.com/cs/ww/en/view/49948856)
PROFINET interface (X2 P1 and X3 P1)	Die CPU has an X2 interface with one port (X2 P1) and an X3 interface with one port (X3 P1). Interfaces X2 and X3 support the basic functions of PROFINET.	
H-Sync interfaces (X4 P1 and X5 P1)	Die CPU has an X4 interface with one port (X4 P1) and an X5 interface with one port (X5 P1). The X4 and X5 interfaces are reserved for the synchronization of the two CPUs.	
Synchronization modules	Make the redundancy connections between the two CPUs via the synchronization modules with fiber-optic cables. You plug each synchronization modules in the X4 and X5 interfaces.	
Fiber-optic cables	You connect the two synchronization modules in pairs to each CPU via a fiber-optic cable.	
Operation of the CPUs as IO controllers	<p>IO controller: As IO controllers the CPUs address the following configured IO devices:</p> <ul style="list-style-type: none"> IO devices with system redundancy S2 IO devices with system redundancy R1 (as of FW version V3.0) Standard IO devices (switched S1 devices) 	

Accessories

You can find information on the topic of "Accessories/spare parts" in the system manual for Redundant System S7-1500R/H (<https://support.industry.siemens.com/cs/ww/en/view/109754833>).

3.4 Firmware functions

Functions

CPU 1518HF-4 PN supports the following firmware functions:

Function	Description	Additional information
CPU redundancy	There are two duplicate CPUs that synchronize their data via two duplex fiber-optic cables, which connect the CPUs directly to each other via plug-in synchronization modules. If one of the CPUs fails, the other CPU retains control of the process.	S7-1500R/H redundant system (https://support.industry.siemens.com/cs/ww/en/view/109754833) System Manual
Safety Integrated	The integrated F-functionality processes standard and safety programs. This allows fail-safe data to be evaluated in the standard user program. As a result of the integration, the system advantages and the extensive functionality of SIMATIC are also available for fail-safe applications. The F-CPU is certified for use in safety mode up to: <ul style="list-style-type: none"> • Safety Integrity Level SIL3 acc. to IEC 61508 • Performance Level (PL) e and Category 4 according to ISO 13849-1:2006 or according to EN ISO 13849-1 Additional password protection for F-configuration and F-program is set up for IT security.	SIMATIC Safety - Configuring and Programming (https://support.industry.siemens.com/cs/ww/en/view/54110126) Programming and Operating Manual
Web API of the Web server (Application Programming Interface)	An overview of which mechanisms and methods support the CPU can be found in the Web server Function Manual.	Web server (https://support.industry.siemens.com/cs/de/en/view/59193560) Function Manual
Integrated system diagnostics	The system automatically generates the messages for the system diagnostics and outputs these messages via a programming device/PC, HMI device or the integrated display. System diagnostics information is also available when the CPUs are in operating state STOP.	Diagnostics (https://support.industry.siemens.com/cs/ww/en/view/59192926) Function Manual
Integrated trace functionality	Trace functionality supports you in troubleshooting and/or optimizing the user program. You record device tags and evaluate the recordings with the trace and logic analyzer function. Tags are, for example, drive parameters or system and user tags of a CPU. Trace and logic analyzer functions are suitable for monitoring highly dynamic processes. Note: Note that the S7-1500R/H redundant system supports recording of measurements. However, saving the measurements to the SIMATIC Memory Card is not supported.	Using the trace and logic analyzer function (https://support.industry.siemens.com/cs/ww/en/view/64897128) Function Manual

3.4 Firmware functions

Function	Description	Additional information
OPC UA as server	An OPC UA server provides information within a network, e.g. relating to the CPU, the OPC UA server itself, the data, and the data types. An OPC UA client accesses this information.	Communication (https://support.industry.siemens.com/cs/ww/en/view/59192925) Function Manual
PROFINET IO		
System redundancy S2	IO-Devices with S2 system redundancy enable uninterrupted operation during a primary backup switchover. If the role of the CPUs changes, the new primary CPU takes over the PROFINET IO communication.	<ul style="list-style-type: none"> S7-1500R/H redundant system (https://support.industry.siemens.com/cs/ww/en/view/109754833) System Manual PROFINET Function Manual (https://support.industry.siemens.com/cs/ww/en/view/49948856)
System redundancy R1	IO devices with R1 system redundancy are equipped with two interface modules compared to S2 devices. If one interface module fails, the R1 device can still be reached by the H-CPU's via the second interface module. Thus, R1 devices have a higher availability than S2 devices.	
Switched S1 device	The switched S1 device function of the CPU enables operation of standard IO devices in the S7-1500R/H redundant system.	S7-1500R/H redundant system (https://support.industry.siemens.com/cs/ww/en/view/109754833) System Manual
RT (real time)	RT prioritizes PROFINET IO frames over standard frames. This ensures the required determinism in the automation technology. In this process the data is transferred via prioritized Ethernet frames.	PROFINET Function Manual (https://support.industry.siemens.com/cs/ww/en/view/49948856)
MRP (Media Redundancy Protocol)	The Media Redundancy Protocol enables the configuration of redundant networks. Redundant transmission links (ring topology) ensure that an alternative communication path is made available if a transmission link fails. Within the PROFINET ring, the H-CPU's assume the role of the MRP Manager following appropriate project configuration and all other devices in the ring assume the role of the MRP clients.	
MRP interconnection	The process MRP interconnection is an enhancement of MRP and allows redundant coupling of two or more rings with MRP in PROFINET networks. MRP interconnection is like MRP - specified in the standard IEC 62439-2 (Edition 3).	
PROFInergy	PROFInergy is a PROFINET-based data interface for switching off consumers centrally and with full coordination during pause times regardless of the manufacturer or device type. Through this, the process should only be provided with the energy that is absolutely required. Most of the energy is saved by the process. The PROFINET device itself only contributes a few watts to the savings potential.	
Integrated technology		
Integrated closed-loop control functionality	<ul style="list-style-type: none"> PID Compact (continuous PID controller) PID 3Step (step controller for integrating actuators) PID Temp (temperature controller for heating and cooling with two separate actuators) 	PID control Function Manual (https://support.industry.siemens.com/cs/ww/en/view/108210036)

Function	Description	Additional information
Controlling, measuring and position detection	<ul style="list-style-type: none"> TO_BasicPos (control of a SINAMICS drive) SSI_Absolute_Encoder (control of position detection and measuring function of the TM PosInput technology module) 	STEP 7 online help
Security Integrated		
Know-how protection	The know-how protection protects user blocks against unauthorized access and modifications.	S7-1500R/H redundant system (https://support.industry.siemens.com/cs/ww/en/view/109754833) System Manual
Local user management (as of FW version V3.1)	Improved management of users, roles, and CPU function rights (User Management & Access Control, UMAC). You can use the local user management in the editor to manage all project users along with their rights (e.g. access rights) for users and roles of the project in the TIA Portal.	
Access protection (up to FW version V3.0)	You can use authorization levels to assign separate rights to different user groups.	
Integrity protection	The CPUs feature an integrity protection function by default. This helps to detect any manipulation of the engineering data on the SIMATIC Memory Card or during data transfer between the TIA Portal and the CPU, and to check communication from a SIMATIC HMI system to the CPU for possible manipulation of engineering data. The user receives a corresponding message about manipulation of engineering data detected by the integrity protection.	
Password provider	As an alternative to manual password entry, you can link a password provider to STEP 7. A password provider offers the following advantages: <ul style="list-style-type: none"> Convenient handling of passwords. STEP 7 automatically imports the password for the blocks. This saves you time. Optimum block protection because the users do not know the password itself. 	

3.5 Operator controls and display elements

3.5.1 Front view of the CPU with closed front flap

The following figure shows the front view of the CPU 1518HF-4 PN.



- ① LEDs for the current operating state and diagnostic status of the CPU
- ② Front panel with display
- ③ Display
- ④ Control keys
- ⑤ Front panel of the X4 and X5 interfaces

Figure 3-3 View of CPU 1518HF-4 PN (with front panel) - front

NOTE

Temperature range for display

To increase its service life, the display switches off at a temperature below the permitted operating temperature of the device. When the display cools down, it automatically switches itself on again. When the display is switched off, the LEDs continue to show the status of the CPU.

For more information on the temperatures at which the display switches itself on and off, refer to the Technical specifications ([Page 40](#)).

Pulling and plugging the front panel with display

You can pull and plug the front panel with display during operation.

WARNING

Personal injury and damage to property may occur

If you remove or attach the front panel of a redundant system S7-1500R/H during operation, personal injury or damage to property can occur in hazardous area zone 2.

Before you remove or fit the front panel, always switch off the power supply to the S7-1500R/H redundant system in hazardous area zone 2.

Locking the front panel

You can lock the front panel to protect the SIMATIC memory card and the mode selector of the CPU against unauthorized access.

You can attach a security seal or a padlock with a hoop diameter of 3 mm to the front panel.

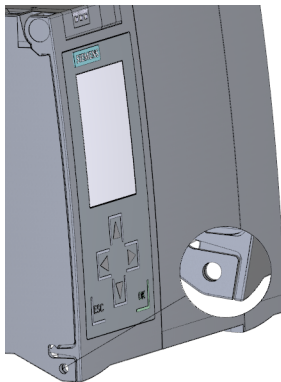

Figure 3-4 Locking latch on the CPU

In addition to the mechanical lock, you can also block access to a password-protected CPU on the display (local lock) and assign a password for the display. You can find additional information on the display, the configurable protection levels and the local lock in the system manual for Redundant System S7-1500R/H

(<https://support.industry.siemens.com/cs/ww/en/view/109754833>).

Reference

You can find detailed information on the individual display options, a training course and a simulation of the available menu commands in the SIMATIC S7-1500 Display Simulator

(<https://support.industry.siemens.com/cs/ww/en/view/109761758>).

3.5.2 Front view of the CPU without front flaps

The figure below shows the operator controls and connection elements of CPU 1518HF-4 PN.

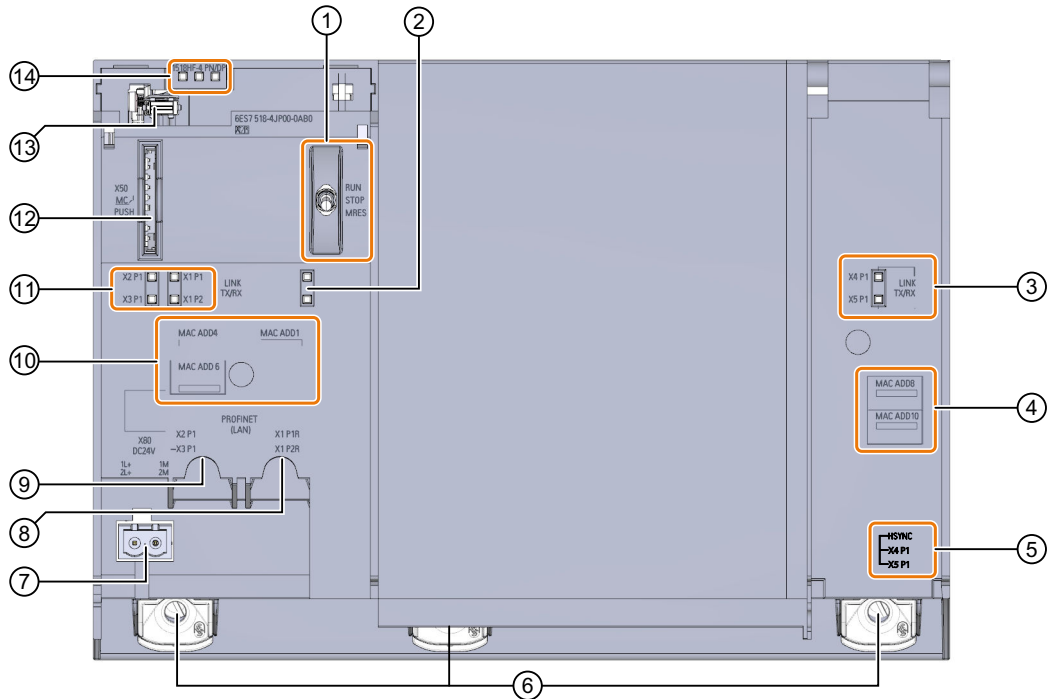

- ① Mode selector
- ② No function
- ③ LED displays for the ports of the X4 and X5 interfaces
- ④ MAC addresses of the X4 and X5 interfaces
- ⑤ H-Sync X4 and X5 interfaces with 1 port each (not visible in graphic)
- ⑥ Fixing screws
- ⑦ Connector for power supply
- ⑧ PROFINET IO interface X1 with 2 ports
- ⑨ PROFINET IO interface X2 and X3 each with 1 port
- ⑩ MAC addresses of the X1, X2 and X3 interfaces
- ⑪ LED displays for the ports of the X1, X2 and X3 interfaces
- ⑫ Slot for the SIMATIC memory card
- ⑬ Display connector
- ⑭ LEDs for the current operating state and diagnostic status of the CPU

Figure 3-5 View of CPU 1518HF-4 PN (without front panel) - front

3.5.3 Rear view of the CPU

The following figure shows the connection elements on the rear of CPU 1518HF-4 PN.

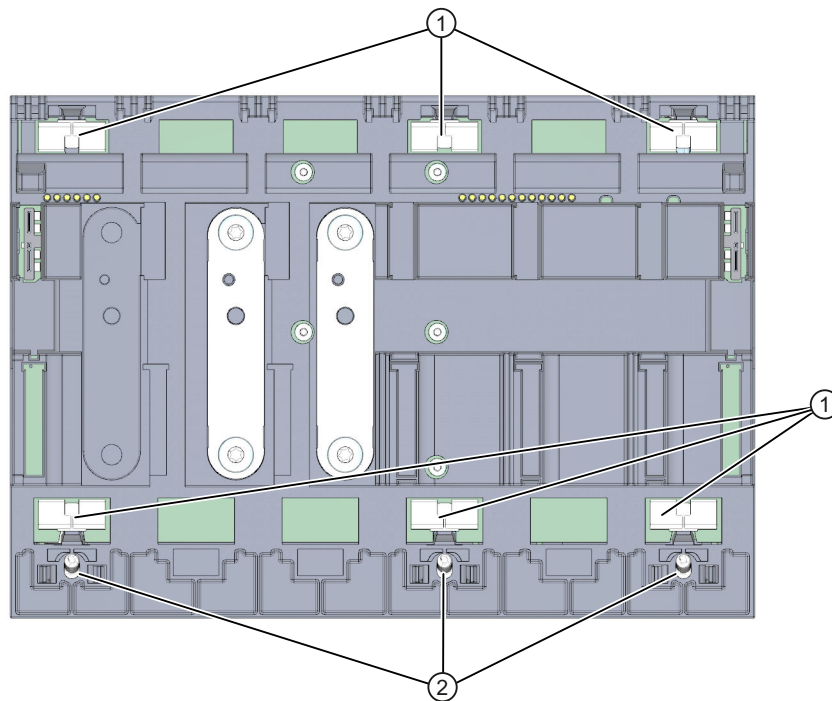

- ① Shield contact surfaces
- ② Fixing screws

Figure 3-6 View of CPU 1518HF-4 PN - rear

3.5.4 Bottom view

Interfaces and synchronization modules

The figure below shows the position of the interfaces on the underside of the CPU.

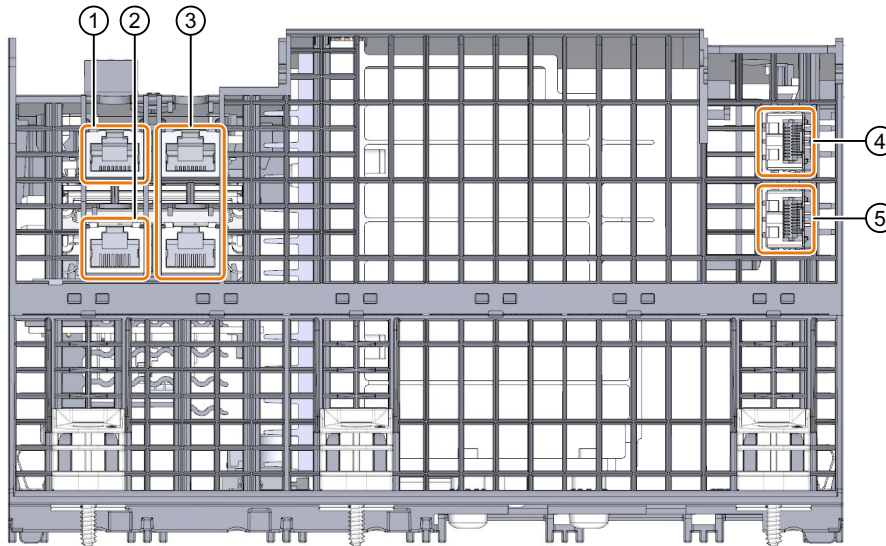

- ① PROFINET IO interface X2 with 1 port
- ② PROFINET IO interface X3 with 1 port
- ③ PROFINET IO interface X1 with 2 ports
- ④ H-Sync interface X4 (H-Sync channel 1) without synchronization module
- ⑤ H-Sync interface X5 (H-Sync channel 2) without synchronization module

Figure 3-7 Bottom view

3.6 Mode selector

You use the mode selector to:

- Request a change to a specific operating state
- Disable or enable the change of a specific operating state
(if, for example, the mode selector is set to STOP, you cannot switch the CPU to RUN via a communication task configured in the TIA Portal or via the display)

The following table shows the position of the switch and the corresponding meaning.

Table 3-1 Mode switch settings

Position	Meaning	Explanation
RUN	RUN operating state	The CPU has permission to go to RUN.
STOP	STOP operating state	The CPU does not have permission to go to RUN.
MRES	Memory reset	Position for CPU memory reset.

Reference

You can find a brief overview of the various operating states and system states in the section Status and error display of the CPU (Page 35).

You can find a detailed description of the operating states and system states in the system manual for S7-1500R/H Redundant System

(<https://support.industry.siemens.com/cs/ww/en/view/109754833>).

Connecting

4.1 Terminal assignment

This section provides information on the terminal assignment of the individual interfaces and the block diagram of the CPU 1518HF-4 PN.

24 V DC supply voltage (X80)

The connector for the power supply is plugged in when the CPU ships from the factory. The following table shows the signal names and the descriptions of the pin assignment of the 24 V DC supply voltage.

Table 4-1 Pin assignment 24 V DC supply voltage

View	Signal name ¹⁾		Description
Connector			
	1	1L+	+ 24 V DC of the supply voltage
	2	1M	Ground of the supply voltage
	3	2M	Ground of the supply voltage for loop-through ²⁾
	4	2L+	+ 24 V DC of the supply voltage for loop-through ²⁾

1) 1L+ and 2L+ as well as 1M and 2M are bridged internally

2) Maximum 10 A permitted

You can find information on the various supply options in the S7-1500R/H redundant system System Manual

PROFINET interface X1 with 2-port switch (X1 P1R and X1 P2R)

The assignment corresponds to the Ethernet standard for an RJ45 plug.

- When autonegotiation is deactivated, the RJ45 socket is allocated as a switch (MDI-X).
- When autonegotiation is activated, autocrossing is in effect and the RJ45 socket is allocated either as data terminal equipment (MDI) or a switch (MDI-X).

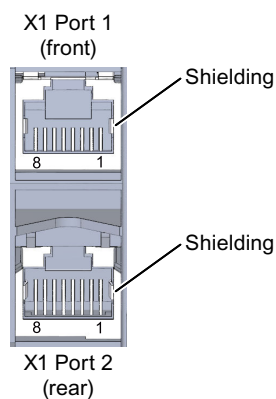

Figure 4-1 Interface assignment X1

PROFINET interface X2 with 1 port (X2 P1) and X3 with port (X3 P1)

The assignment corresponds to the Ethernet standard for a RJ45 connector.

Autocrossing is always active on X2 and X3. This means the RJ45 sockets are allocated either as data terminal equipment (MDI) or a switch (MDI-X).

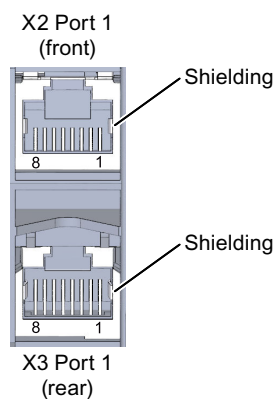

Figure 4-2 Interface assignment X2, X3

H-Sync X4 interface with 1 port (X4 P1) and X5 with 1 port (X5 P1)

Make the redundancy connections between the two CPUs via the synchronization modules at the X4 P1 and X5 P1 interfaces (LC sockets). You interconnect the CPUs in pairs via the fiber-optic cables. Use the connector types LC/PC or LC/UPC for this.

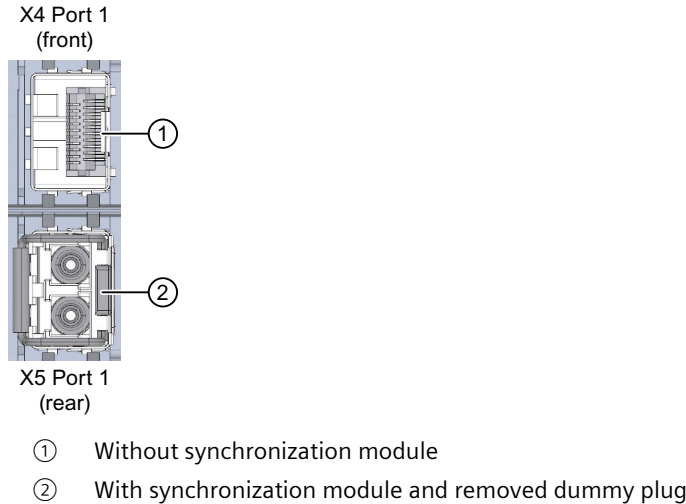

Figure 4-3 Interface assignment X4, X5

Additional information

You can find more information on the topic of "Connecting the CPU" and on the topic "Accessories/spare parts" in the S7-1500R/H redundant system System Manual.

Assignment of the MAC addresses

CPU 1518HF-4 PN has for each CPU:

- One PROFINET interface with two ports
- Two PROFINET interfaces with one port each
- Two H-Sync interfaces with one port each

Each of the interfaces has a MAC address. Each port also has a separate MAC address. There are a total of 22 MAC addresses for the two CPUs of the CPU 1518HF-4 PN.

The MAC addresses of the ports are needed for the LLDP protocol, for example for the neighborhood discovery function.

The number range of the MAC addresses is sequential. The first and last MAC addresses are printed on the rating plate on the right side of each CPU 1518HF-4 PN.

The table below shows how the MAC addresses are assigned.

Table 4-2 Distribution of the MAC addresses of a CPU

	Assignment	Labeling
MAC address 1	PROFINET interface X1 (visible in STEP 7 when devices are accessible)	<ul style="list-style-type: none"> • Front printed • Right-side printed (start of number range)
MAC address 2	Port X1 P1R (required for LLDP, for example)	---

	Assignment	Labeling
MAC address 3	Port X1 P2R (required for LLDP, for example)	---
MAC address 4	PROFINET interface X2 (visible in STEP 7 when devices are accessible)	• Front printed
MAC address 5	Port X2 P1 (required for LLDP, for example)	---
MAC address 6	PROFINET interface X3 (visible in STEP 7 when devices are accessible)	• Front printed
MAC address 7	Port X3 P1 (required for LLDP, for example)	---
MAC address 8	H-Sync interface X4	• Front printed
MAC address 9	Port X4 P1	---
MAC address 10	H-Sync interface X5	• Front printed
MAC address 11	Port X5 P1	• Right-side printed (end of number range)

Block diagram

The following figure shows the block diagram of CPU 1518HF-4 PN.

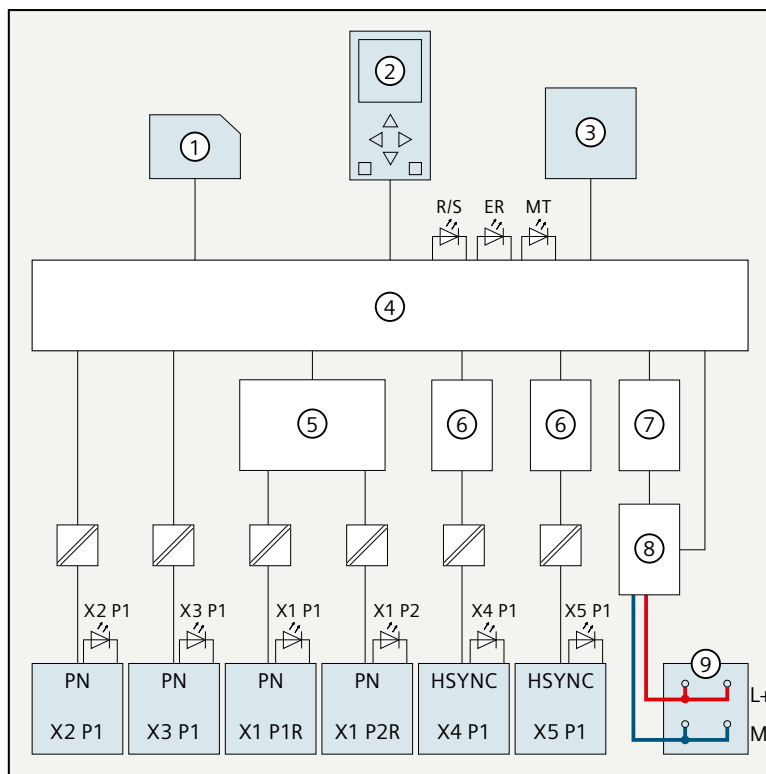

- | | | | |
|---|---------------------------|-------------|------------------------------|
| ① | SIMATIC Memory Card (X50) | PN X2 P1 | PROFINET interface X2 port 1 |
| ② | Display | PN X3 P1 | PROFINET interface X3 Port 1 |
| ③ | Mode switch RUN/STOP/MRES | HSYNC X4 P1 | H-Sync interface X4 port 1 |
| ④ | Electronics | HSYNC X5 P1 | H-Sync interface X5 port 1 |
| ⑤ | PROFINET 2-port switch | L+ | 24 V DC supply voltage |

4.1 Terminal assignment

⑥	Synchronization interface	M	Ground
⑦	Backplane bus connection (connection to backplane bus not configurable)	R/S	RUN/STOP LED (yellow/green)
⑧	Internal supply voltage	ER	ERROR LED (red)
⑨	Supply of the 24 V DC supply voltage (X80)	MT	MAINT LED (yellow)
PN X1 P1R	PROFINET interface X1 port 1	X1 P1, X1 P2, X2 P1, X3 P1, X4 P1, X5 P1	LED Link TX/RX
PN X1 P2R	PROFINET interface X1 port 2		

Figure 4-4 Block diagram of CPU 1518HF-4 PN

See also

Redundant System S7-1500R/H System Manual
(<https://support.industry.siemens.com/cs/ww/en/view/109754833>)

Alarm, error and system messages

5.1 Status and error display of the CPU

The LED displays of the CPU are described below.

You can find more detailed information on "Interrupts" in the STEP 7 online help.

You can find additional information on the topic of "Diagnostics" and "System events" in the Diagnostics (<https://support.industry.siemens.com/cs/ww/en/view/59192926>) Function Manual and in the S7-1500R/H redundant system System Manual.

You can find additional information on the topic of "Operating states and system states" as well as various failure scenarios in the S7-1500R/H redundant system System Manual.

LED display

The figure below shows the LED displays of the CPU 1518HF-4 PN.

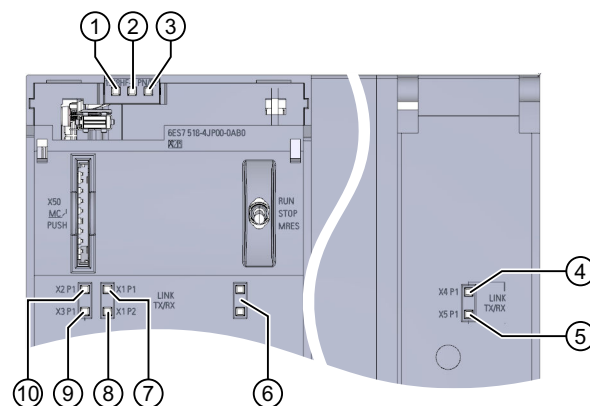

- ① RUN/STOP LED (yellow/green LED)
- ② ERROR LED (red LED)
- ③ MAINT LED (yellow LED)
- ④ LINK RX/TX LED for port X4 P1 (yellow/green LED)
- ⑤ LINK RX/TX LED for port X5 P1 (yellow/green LED)
- ⑥ No function
- ⑦ LINK RX/TX LED for port X1 P1 (yellow/green LED)
- ⑧ LINK RX/TX LED for port X1 P2 (yellow/green LED)
- ⑨ LINK RX/TX LED for port X3 P1 (yellow/green LED)
- ⑩ LINK RX/TX LED for port X2 P1 (yellow/green LED)

Figure 5-1 LED display of CPU 1518HF-4 PN (without front flap)

LED displays depending on operating states and system states

CPU 1518HF-4 PN has the following LEDs for displaying the current operating state and diagnostics status.

- RUN/STOP LED
- ERROR LED
- MAINT LED

The LEDs indicate the operating state of the respective CPU within the redundant system. Operating states describe the behavior of a single CPU at a specific time. The combination of the operating states of the CPUs forms the system state.

The following figure shows the possible operating states of the CPUs and the resulting system states.

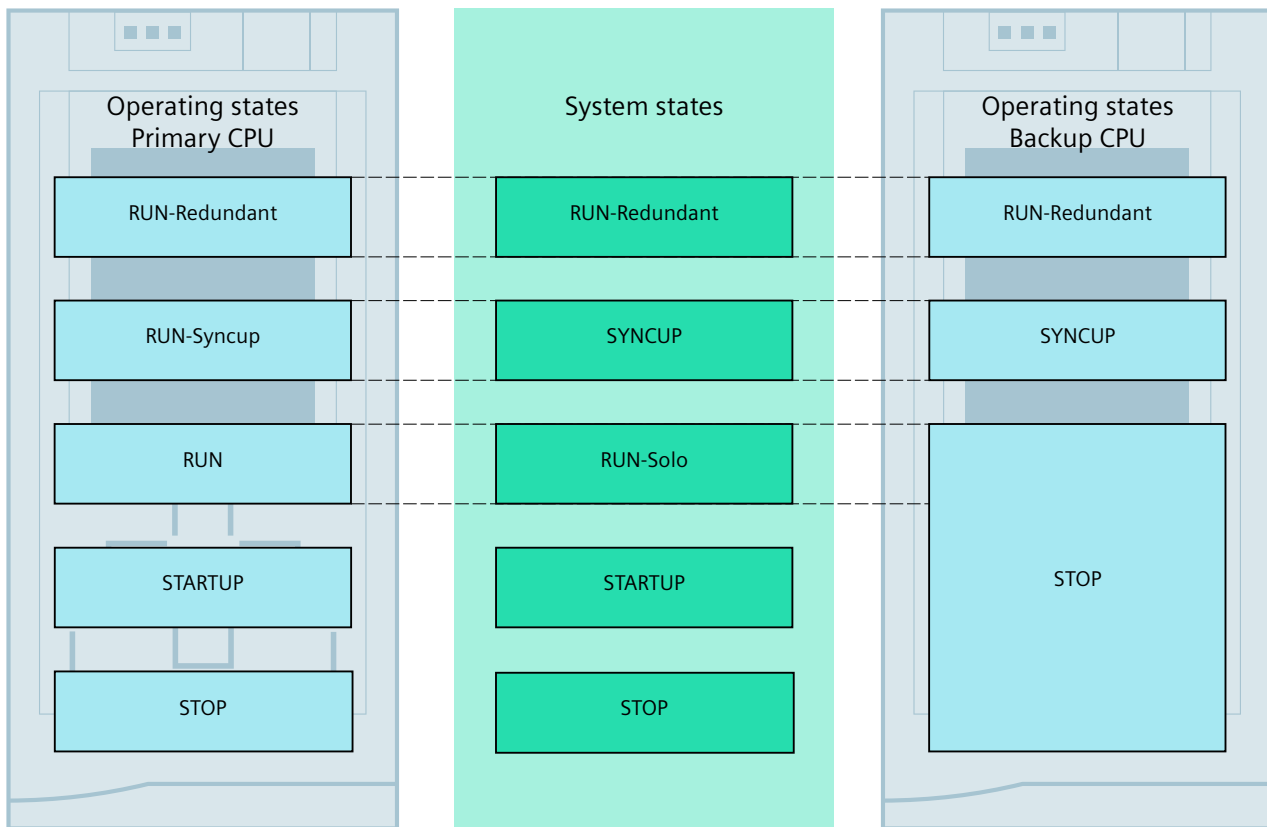

Figure 5-2 Operating states and system states

Meaning of the RUN/STOP, ERROR and MAINT LEDs

CPU 1518HF-4 PN has three LEDs for displaying the current operating state and diagnostics status.

NOTE

LED patterns of the S7-1500H redundant system

Note that it is not always possible to:

- Determine the state of the CPU from the signal pattern of individual LEDs
- Determine the state of the other CPU from the signal pattern of a CPU



























The "Meaning" column only shows a possible typical cause.

To investigate the cause of the signal pattern, use the diagnostic buffer and its display via:

- STEP 7
- HMI devices
- Displays of the CPUs













The following table shows the meaning of the various color combinations for the RUN/STOP, ERROR and MAINT LEDs.

Table 5-1 Meaning of the LEDs

RUN/STOP LED	ERROR LED	MAINT LED	Meaning
 LED off	 LED off	 LED off	Missing or insufficient supply voltage on the CPU.
 LED flashes yellow/green	 LED flashes red	 LED flashes yellow	Startup (CPU booting)
			Test of LEDs during startup, inserting a module.
			LED flashing test
 LED lit yellow	 LED off	 LED lit yellow	CPU is in operating state STOP.
			Completion of system initialization
 LED flashes yellow	 LED off	 LED lit yellow	CPU executes internal activities in an operating state ≠ RUN-Redundant.
 LED lit yellow	 LED flashes red	 LED flashes yellow	CPU defective Firmware update using SIMATIC Memory Card has failed.
 LED lit yellow	 LED off	 LED flashes yellow	Firmware update successfully completed.
 LED flashes yellow/green	 LED off	 LED lit yellow	The primary CPU is in STARTUP operating state. The backup CPU is in SYNCUP operating state.
 LED flashes yellow	 LED off	 LED off	The CPU performs a warm restart.
 LED lit green	 LED off	 LED lit yellow	Maintenance demanded for the plant. You need to check/replace the affected hardware within a short period of time.

¹⁾ If there is not enough storage space on a SIMATIC Memory Card or on both SIMATIC Memory Cards in RUN-Redundant, the write function is aborted and the redundant system continues operation with the original configuration. The redundant system will remain in the RUN-Redundant system state.

5.1 Status and error display of the CPU

RUN/STOP LED	ERROR LED	MAINT LED	Meaning
 LED lit green	 LED off	 LED lit yellow	The primary CPU is in the RUN or RUN-Syncup operating state. Active Force job Warning limit for F-cycle violated Safety mode deactivated
 LED lit green	 LED off	 LED off	The CPU is in RUN-Redundant operating state. There are no events, requirements, errors, etc.
 LED lit green	 LED flashes red	 LED off	A diagnostic event is pending in RUN-Redundant operating state.
 LED lit green	 LED flashes red	 LED lit yellow	A diagnostic event is present (e.g. failure of an IO device within the PROFINET ring or no access to SIMATIC Memory Card possible ¹⁾) and maintenance is demanded (e.g. interruption of the PROFINET ring).

¹⁾ If there is not enough storage space on a SIMATIC Memory Card or on both SIMATIC Memory Cards in RUN-Redundant, the write function is aborted and the redundant system continues operation with the original configuration. The redundant system will remain in the RUN-Redundant system state.

NOTE

MAINT LED of the two CPUs

The MAINT LEDs of both CPUs only go out when the following conditions are fulfilled:

- The CPUs are in the RUN-Redundant system state.
- No maintenance is demanded.

NOTE





LED displays in redundant operating state

In the RUN-Redundant system state, the LED displays on both CPUs are identical (exception: you are performing an LED flash test on one CPU).

Meaning of LINK RX/TX LED

Each port of the X1, X2, X3, X4 and X5 interfaces has a LINK RX/TX LED. The table below shows the various LED patterns of the CPU 1518HF-4 PN ports.

Table 5-2 Meaning of LINK RX/TX LED

LINK TX/RX LED	Meaning
 Off	There is no connection between the interface of the device and a communication partner. No data is currently being sent/received via the interface. There is no LINK connection. The redundancy connections were interrupted.
 Flashes green	The CPU performs an LED flash test.
 Illuminated green	There is a connection between the interface of the device and a communication partner. The redundancy connections are OK.
 LED flashes yellow/green	Data is currently being received or sent by a communication partner via the interface of the device.

NOTE

"LED" instruction

You can read the status (e.g. "On" or "Off") of LEDs of a CPU or a module using the "LED" instruction. Note, however, that it is not possible to read the LED status of the LINK RX/TX LEDs on all S7-1500 R/H CPUs.

You can find additional information on the "LED" instruction in the STEP 7 online help.

See also

Redundant System S7-1500R/H System Manual
(<https://support.industry.siemens.com/cs/ww/en/view/109754833>)

Technical specifications

The following table shows the technical specifications as of 01/2024. You can find a data sheet including daily updated technical specifications on the Internet (<https://support.industry.siemens.com/cs/ww/en/pv/6ES7518-4JP00-0AB0/td?dl=en>).

Article number	6ES7518-4JP00-0AB0
General information	
Product type designation	CPU 1518HF-4PN
HW functional status	FS04
Firmware version	V3.1
<ul style="list-style-type: none"> FW update possible 	Yes
Product function	
<ul style="list-style-type: none"> I&M data 	Yes; I&M0 to I&M3
<ul style="list-style-type: none"> Isochronous mode 	No
<ul style="list-style-type: none"> SysLog 	Yes
Engineering with	
<ul style="list-style-type: none"> STEP 7 TIA Portal configurable/integrated from version 	V19 (FW V3.1) / V17 (FW 2.9) or higher
Display	
Screen diagonal [cm]	6.1 cm
Control elements	
Number of keys	6
Mode selector switch	1
Supply voltage	
Rated value (DC)	24 V
permissible range, lower limit (DC)	19.2 V
permissible range, upper limit (DC)	28.8 V
Reverse polarity protection	Yes
Mains buffering	
<ul style="list-style-type: none"> Mains/voltage failure stored energy time 	5 ms
<ul style="list-style-type: none"> Repeat rate, min. 	1/s
Input current	
Current consumption (rated value)	1.55 A
Current consumption, max.	1.95 A
Inrush current, max.	1.95 A; Rated value
I^2t	0.4 A ² ·s
Power loss	
Power loss, typ.	24 W

Article number	6ES7518-4JP00-0AB0
Memory	
Number of slots for SIMATIC memory card	1
SIMATIC memory card required	Yes
Work memory	
• integrated (for program)	9 Mbyte
• integrated (for data)	60 Mbyte
Load memory	
• Plug-in (SIMATIC Memory Card), max.	32 Gbyte
Backup	
• maintenance-free	Yes
CPU processing times	
for bit operations, typ.	4 ns
for word operations, typ.	6 ns
for fixed point arithmetic, typ.	6 ns
for floating point arithmetic, typ.	24 ns
CPU-blocks	
Number of elements (total)	20 000; Blocks (OB, FB, FC, DB) and UDTs
DB	
• Number range	1 ... 60 999; subdivided into: number range that can be used by the user: 1 ... 59 999, and number range of DBs created via SFC 86: 60 000 ... 60 999
• Size, max.	16 Mbyte; For DBs with absolute addressing, the max. size is 64 KB
FB	
• Number range	0 ... 65 535
• Size, max.	1 Mbyte
FC	
• Number range	0 ... 65 535
• Size, max.	1 Mbyte

Article number	6ES7518-4JP00-0AB0
OB	
<ul style="list-style-type: none"> • Size, max. • Number of free cycle OBs • Number of time alarm OBs • Number of delay alarm OBs • Number of cyclic interrupt OBs • Number of process alarm OBs • Number of DPV1 alarm OBs • Number of startup OBs • Number of asynchronous error OBs • Number of synchronous error OBs • Number of diagnostic alarm OBs 	<p>1 Mbyte</p> <p>100</p> <p>20</p> <p>20</p> <p>20; with minimum OB 3x cycle of 1 ms</p> <p>50</p> <p>3</p> <p>100</p> <p>4</p> <p>2</p> <p>1</p>
Nesting depth	
<ul style="list-style-type: none"> • per priority class 	24; Up to 8 possible for F-blocks
Counters, timers and their retentivity	
S7 counter	
<ul style="list-style-type: none"> • Number 	2 048
Retentivity	
– adjustable	Yes
IEC counter	
<ul style="list-style-type: none"> • Number 	Any (only limited by the main memory)
Retentivity	
– adjustable	Yes
S7 times	
<ul style="list-style-type: none"> • Number 	2 048
Retentivity	
– adjustable	Yes
IEC timer	
<ul style="list-style-type: none"> • Number 	Any (only limited by the main memory)
Retentivity	
– adjustable	Yes
Data areas and their retentivity	
Retentive data area (incl. timers, counters, flags), max.	768 kbyte; In total; available retentive memory for bit memories, timers, counters, DBs, and technology data (axes): 700 KB
Flag	
<ul style="list-style-type: none"> • Size, max. • Number of clock memories 	<p>16 kbyte</p> <p>8; 8 clock memory bit, grouped into one clock memory byte</p>

Article number	6ES7518-4JP00-0AB0
Data blocks	
<ul style="list-style-type: none"> • Retentivity adjustable 	Yes
<ul style="list-style-type: none"> • Retentivity preset 	No
Local data	
<ul style="list-style-type: none"> • per priority class, max. 	64 kbyte; max. 16 KB per block
Address area	
Number of IO modules	8 192; max. number of modules / submodules
I/O address area	
<ul style="list-style-type: none"> • Inputs 	32 kbyte; All inputs are in the process image
<ul style="list-style-type: none"> • Outputs 	32 kbyte; All outputs are in the process image
per integrated IO subsystem	
<ul style="list-style-type: none"> – Inputs (volume) 	16 kbyte
<ul style="list-style-type: none"> – Outputs (volume) 	16 kbyte
Subprocess images	
<ul style="list-style-type: none"> • Number of subprocess images, max. 	31
Hardware configuration	
Number of distributed IO systems	64; A distributed I/O system is characterized not only by the integration of distributed I/O via PROFINET, but also by the connection of I/O via IE/PB-Links.
Number of IO Controllers	
<ul style="list-style-type: none"> • integrated 	1
Rack	
<ul style="list-style-type: none"> • Modules per rack, max. 	9; CPU + 2 PS + 6 CP
Time of day	
Clock	
<ul style="list-style-type: none"> • Type 	Hardware clock
<ul style="list-style-type: none"> • Backup time 	6 wk; At 40 °C ambient temperature, typically
<ul style="list-style-type: none"> • Deviation per day, max. 	10 s; Typ.: 2 s
Operating hours counter	
<ul style="list-style-type: none"> • Number 	16
Clock synchronization	
<ul style="list-style-type: none"> • supported 	Yes
<ul style="list-style-type: none"> • on Ethernet via NTP 	Yes
Interfaces	
Number of PROFINET interfaces	3

Article number	6ES7518-4JP00-0AB0
1. Interface	
Interface types	
<ul style="list-style-type: none"> • RJ 45 (Ethernet) 	Yes; X1
<ul style="list-style-type: none"> • Number of ports 	2
<ul style="list-style-type: none"> • integrated switch 	Yes
Protocols	
<ul style="list-style-type: none"> • IP protocol 	Yes; IPv4
<ul style="list-style-type: none"> • PROFINET IO Controller 	Yes
<ul style="list-style-type: none"> • PROFINET IO Device 	No
<ul style="list-style-type: none"> • SIMATIC communication 	Yes; Only Server
<ul style="list-style-type: none"> • Open IE communication 	Yes; Optionally also encrypted
<ul style="list-style-type: none"> • Web server 	Yes
<ul style="list-style-type: none"> • Media redundancy 	Yes
PROFINET IO Controller	
Services	
<ul style="list-style-type: none"> – Isochronous mode 	No
<ul style="list-style-type: none"> – IRT 	No
<ul style="list-style-type: none"> – PROFIenergy 	Yes; per user program
<ul style="list-style-type: none"> – Number of connectable IO Devices, max. 	256
<ul style="list-style-type: none"> – Updating times 	The minimum value of the update time also depends on communication share set for PROFINET IO, on the number of IO devices, and on the quantity of configured user data
<ul style="list-style-type: none"> – PROFINET Security Class 	1
Update time for RT	
<ul style="list-style-type: none"> – for send cycle of 1 ms 	1 ms to 512 ms
2. Interface	
Interface types	
<ul style="list-style-type: none"> • RJ 45 (Ethernet) 	Yes; X2
<ul style="list-style-type: none"> • Number of ports 	1
<ul style="list-style-type: none"> • integrated switch 	No
Protocols	
<ul style="list-style-type: none"> • IP protocol 	Yes; IPv4
<ul style="list-style-type: none"> • PROFINET IO Controller 	No
<ul style="list-style-type: none"> • PROFINET IO Device 	No
<ul style="list-style-type: none"> • SIMATIC communication 	Yes; Only Server
<ul style="list-style-type: none"> • Open IE communication 	Yes; Optionally also encrypted
<ul style="list-style-type: none"> • Web server 	Yes
<ul style="list-style-type: none"> • Media redundancy 	No

Article number	6ES7518-4JP00-0AB0
3. Interface	
Interface types	
<ul style="list-style-type: none"> RJ 45 (Ethernet) 	Yes; X3
<ul style="list-style-type: none"> Number of ports 	1
<ul style="list-style-type: none"> integrated switch 	No
Protocols	
<ul style="list-style-type: none"> IP protocol 	Yes; IPv4
<ul style="list-style-type: none"> SIMATIC communication 	Yes; Only Server
<ul style="list-style-type: none"> Open IE communication 	Yes; Optionally also encrypted
<ul style="list-style-type: none"> Web server 	Yes
4. Interface	
Interface type	Pluggable synchronization submodule (FO)
Plug-in interface modules	Synchronization module 6ES7960-1CB00-0AA5, 6ES7960-1FB00-0AA5 or 6ES7960-1FE00-0AA5
5. Interface	
Interface type	Pluggable synchronization submodule (FO)
Plug-in interface modules	Synchronization module 6ES7960-1CB00-0AA5, 6ES7960-1FB00-0AA5 or 6ES7960-1FE00-0AA5
Interface types	
RJ 45 (Ethernet)	
<ul style="list-style-type: none"> 100 Mbps 	Yes
<ul style="list-style-type: none"> 1000 Mbps 	Yes; Only possible at the X3 interface of the CPU 1518
<ul style="list-style-type: none"> Autonegotiation 	Yes
<ul style="list-style-type: none"> Autocrossing 	Yes
<ul style="list-style-type: none"> Industrial Ethernet status LED 	Yes
Protocols	
PROFIsafe	Yes; V2.4 / V2.6
Number of connections	
<ul style="list-style-type: none"> Number of connections, max. 	384; via integrated interfaces of the CPU and connected CPs
<ul style="list-style-type: none"> Number of connections reserved for ES/HMI/web 	10
<ul style="list-style-type: none"> Number of connections via integrated interfaces 	320
<ul style="list-style-type: none"> Number of S7 routing paths 	64
Redundancy mode	
<ul style="list-style-type: none"> PROFINET system redundancy (S2) 	Yes
<ul style="list-style-type: none"> PROFINET system redundancy (R1) 	Yes

Article number	6ES7518-4JP00-0AB0
Media redundancy	
– Media redundancy	only via 1st interface (X1)
– MRP	Yes; MRP Automanager according to IEC 62439-2 Edition 2.0
– MRP interconnection, supported	Yes; as MRP ring node according to IEC 62439-2 Edition 3.0
– MRPD	No
– Switchover time on line break, typ.	200 ms; PROFINET MRP
– Number of stations in the ring, max.	50
SIMATIC communication	
• PG/OP communication	Yes; encryption with TLS V1.3 pre-selected
• S7 routing	Yes
• S7 communication, as server	Yes
• S7 communication, as client	No
Open IE communication	
• TCP/IP	Yes
– Data length, max.	64 kbyte
– several passive connections per port, supported	Yes
• ISO-on-TCP (RFC1006)	Yes
– Data length, max.	64 kbyte
• UDP	Yes
– Data length, max.	2 kbyte; 1 472 bytes for UDP broadcast
– UDP multicast	Yes; 128 multicast circuits (of which max. 5 via X1)
• DHCP	No
• DNS	Yes
• SNMP	Yes
• DCP	Yes
• LLDP	Yes
• Encryption	Yes; Optional
Web server	
• HTTP	No
• HTTPS	Yes; only via Web API
• web API	Yes
– Number of sessions, max.	200
– number of simultaneous HTTP calls, max.	4
– HTTP request body, max.	131 072 byte

Article number	6ES7518-4JP00-0AB0
OPC UA	
<ul style="list-style-type: none"> • Runtime license required • OPC UA Client • OPC UA Server <ul style="list-style-type: none"> – Application authentication – Security policies – User authentication – GDS support (certificate management) – Number of sessions, max. – Number of subscriptions per session, max. – Sampling interval, min. – Publishing interval, min. – Number of server methods, max. – Number of inputs/outputs per server method, max. – Number of monitored items, recommended max. – Number of server interfaces, max. – Number of nodes for user-defined server interfaces, max. • Alarms and Conditions 	Yes No Yes; Data access (read, write, subscribe), method call, custom address space Yes available security policies: None, Basic128Rsa15, Basic256Rsa15, Basic256Sha256, Aes128Sha256RsaOaep, Aes256Sha256RsaPss "anonymous" or by user name & password No 32 25 25 ms 25 ms 100 20 12 000; for 1 s sampling interval and 1 s send interval 10 of each "Server interfaces" / "Companion specification" type and 20 of the type "Reference namespace" 50 000 No
Further protocols	
<ul style="list-style-type: none"> • MODBUS 	Yes; MODBUS TCP
S7 message functions	
Number of login stations for message functions, max.	64
number of subscriptions, max.	750
number of tags/attributes for subscriptions, max.	50 000
Program alarms	Yes
Number of configurable program messages, max.	10 000; Program messages are generated by the "Program_Alarm" block, ProDiag or GRAPH
Number of loadable program messages in RUN, max.	10 000
Number of simultaneously active program alarms	
<ul style="list-style-type: none"> • Number of program alarms • Number of alarms for system diagnostics 	4 000 1 000

Article number	6ES7518-4JP00-0AB0
Test commissioning functions	
Joint commission (Team Engineering)	No
Status block	Yes; Up to 16 simultaneously
Single step	No
Number of breakpoints	20; Breakpoints are only supported in RUN-Solo status
Status/control	
<ul style="list-style-type: none"> Status/control variable 	Yes; without fail-safe
<ul style="list-style-type: none"> Variables 	inputs/outputs, bit memories, DBs, peripheral I/Os (without fail-safe), times, counters
<ul style="list-style-type: none"> Number of variables, max. 	
<ul style="list-style-type: none"> – of which status variables, max. 	200; per job
<ul style="list-style-type: none"> – of which control variables, max. 	200; per job
Forcing	
<ul style="list-style-type: none"> Forcing 	Yes; without fail-safe
<ul style="list-style-type: none"> Forcing, variables 	peripheral inputs/outputs (without fail-safe)
<ul style="list-style-type: none"> Number of variables, max. 	200
Diagnostic buffer	
<ul style="list-style-type: none"> present 	Yes
<ul style="list-style-type: none"> Number of entries, max. 	3 200
<ul style="list-style-type: none"> – of which powerfail-proof 	1 000
Traces	
<ul style="list-style-type: none"> Number of configurable Traces 	8
<ul style="list-style-type: none"> Memory size per trace, max. 	512 kbyte
Interrupts/diagnostics/status information	
Diagnostics indication LED	
<ul style="list-style-type: none"> RUN/STOP LED 	Yes
<ul style="list-style-type: none"> ERROR LED 	Yes
<ul style="list-style-type: none"> MAINT LED 	Yes
<ul style="list-style-type: none"> Connection display LINK TX/RX 	Yes
Supported technology objects	
Motion Control	No
Controller	
<ul style="list-style-type: none"> PID_Compact 	Yes; Universal PID controller with integrated optimization
<ul style="list-style-type: none"> PID_3Step 	Yes; PID controller with integrated optimization for valves
<ul style="list-style-type: none"> PID-Temp 	Yes; PID controller with integrated optimization for temperature
Counting and measuring	Yes

Article number	6ES7518-4JP00-0AB0
Standards, approvals, certificates	
Suitable for safety functions	Yes; e.g. emergency stop, acknowledgment button
Highest safety class achievable in safety mode	
<ul style="list-style-type: none"> Performance level according to ISO 13849-1 SIL acc. to IEC 61508 	<p>PLe</p> <p>SIL 3</p>
Probability of failure (for service life of 20 years and repair time of 100 hours)	
<ul style="list-style-type: none"> Low demand mode: PFDavg in accordance with SIL3 High demand/continuous mode: PFH in accordance with SIL3 	<p>< 2.00E-05</p> <p>< 1.00E-09</p>
Ambient conditions	
Ambient temperature during operation	
<ul style="list-style-type: none"> horizontal installation, min. horizontal installation, max. vertical installation, min. vertical installation, max. 	<p>0 °C</p> <p>60 °C; Display: 50 °C, at an operating temperature of typically 50 °C, the display is switched off</p> <p>0 °C</p> <p>40 °C; Display: 40 °C, at an operating temperature of typically 40 °C, the display is switched off</p>
Ambient temperature during storage/transportation	
<ul style="list-style-type: none"> min. max. 	<p>-40 °C</p> <p>70 °C</p>
Altitude during operation relating to sea level	
<ul style="list-style-type: none"> Installation altitude above sea level, max. 	5 000 m; Restrictions for installation altitudes > 2 000 m, see manual
configuration / header	
configuration / programming / header	
Programming language	
<ul style="list-style-type: none"> LAD FBD STL SCL CFC GRAPH 	<p>Yes; incl. failsafe</p> <p>Yes; incl. failsafe</p> <p>Yes</p> <p>Yes</p> <p>No</p> <p>Yes</p>
Know-how protection	
<ul style="list-style-type: none"> User program protection/password protection Copy protection Block protection 	<p>Yes</p> <p>No</p> <p>Yes</p>

Article number	6ES7518-4JP00-0AB0
Access protection	
<ul style="list-style-type: none"> • protection of confidential configuration data • Password for display • Protection level: Write protection • Protection level: Read/write protection • Protection level: Write protection for Failsafe • Protection level: Complete protection • User administration 	<p>Yes</p> <p>Yes</p> <p>Yes</p> <p>Yes</p> <p>Yes</p> <p>Yes</p> <p>Yes</p>
programming / cycle time monitoring / header	
<ul style="list-style-type: none"> • lower limit • upper limit 	<p>adjustable minimum cycle time</p> <p>adjustable maximum cycle time</p>
Dimensions	
Width	210 mm
Height	147 mm
Depth	129 mm
Weights	
Weight, approx.	2 116 g

General technical specifications

You can find information on the general technical specifications, such as standards and approvals, electromagnetic compatibility, protection class, etc. in the S7-1500R/H redundant system System Manual.

See also

Redundant System S7-1500R/H System Manual
<https://support.industry.siemens.com/cs/ww/en/view/109754833>

A

Dimension drawing

This section contains the dimension drawing of the module on the mounting rail, as well as a dimension drawing with the front panel open. Keep to the dimensions when installing in cabinets, control rooms, etc.

Dimension drawings of the CPU 1518HF-4 PN

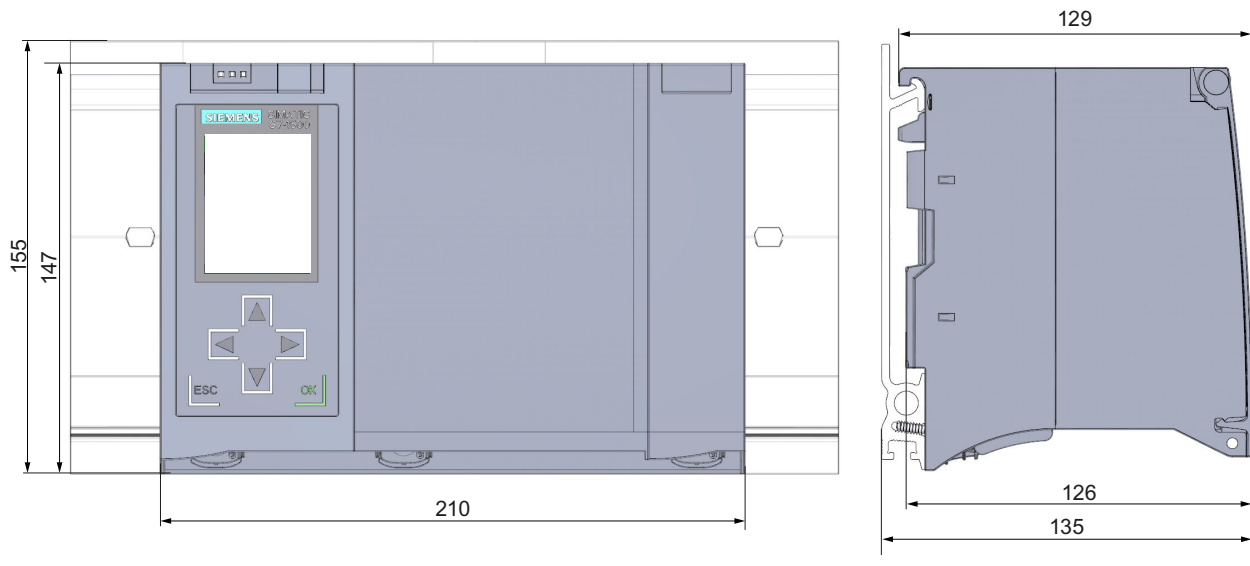

Figure A-1 Dimension drawing of the CPU 1518HF-4 PN, front and side view

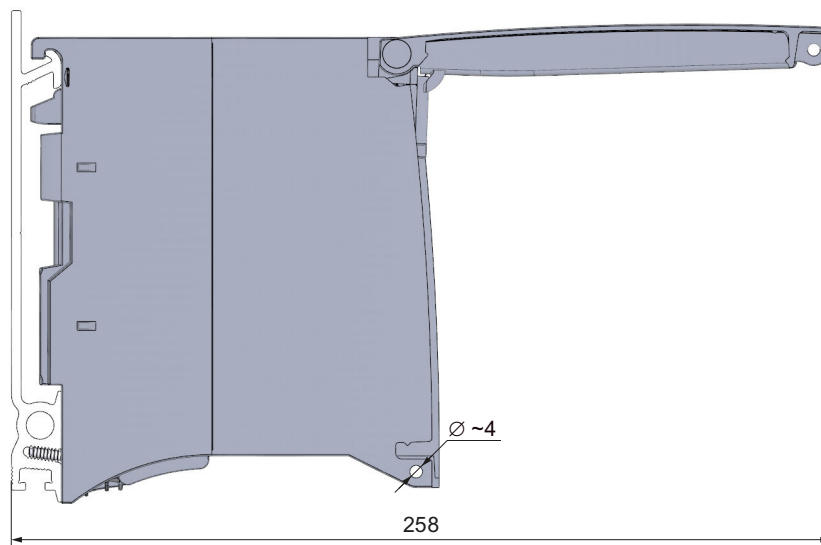

Figure A-2 Dimension drawing of the CPU 1518HF-4 PN, side view with front panel open