



Edition

01/2024

EQUIPMENT MANUAL

SIMATIC

S7-1500R/H

CPU 1515R-2 PN
6ES7515-2RN03-0AB0

support.industry.siemens.com

SIEMENS

SIMATIC

S7-1500R/H
CPU 1515R-2 PN
(6ES7515-2RN03-0AB0)

Equipment Manual

Introduction

1

Industrial cybersecurity

2

Product overview

3

Connecting

4

Interrupts, diagnostics, error
messages and system events

5

Technical specifications

6

Dimension drawing

A



01/2024

A5E42009914-AE

Legal information

Warning notice system

This manual contains notices you have to observe in order to ensure your personal safety, as well as to prevent damage to property. The notices referring to your personal safety are highlighted in the manual by a safety alert symbol, notices referring only to property damage have no safety alert symbol. These notices shown below are graded according to the degree of danger.

 DANGER
indicates that death or severe personal injury will result if proper precautions are not taken.
 WARNING
indicates that death or severe personal injury may result if proper precautions are not taken.
 CAUTION
indicates that minor personal injury can result if proper precautions are not taken.
NOTICE
indicates that property damage can result if proper precautions are not taken.

If more than one degree of danger is present, the warning notice representing the highest degree of danger will be used. A notice warning of injury to persons with a safety alert symbol may also include a warning relating to property damage.

Qualified Personnel

The product/system described in this documentation may be operated only by **personnel qualified** for the specific task in accordance with the relevant documentation, in particular its warning notices and safety instructions. Qualified personnel are those who, based on their training and experience, are capable of identifying risks and avoiding potential hazards when working with these products/systems.

Proper use of Siemens products

Note the following:

 WARNING
Siemens products may only be used for the applications described in the catalog and in the relevant technical documentation. If products and components from other manufacturers are used, these must be recommended or approved by Siemens. Proper transport, storage, installation, assembly, commissioning, operation and maintenance are required to ensure that the products operate safely and without any problems. The permissible ambient conditions must be complied with. The information in the relevant documentation must be observed.

Trademarks

All names identified by ® are registered trademarks of Siemens Aktiengesellschaft. The remaining trademarks in this publication may be trademarks whose use by third parties for their own purposes could violate the rights of the owner.

Disclaimer of Liability

We have reviewed the contents of this publication to ensure consistency with the hardware and software described. Since variance cannot be precluded entirely, we cannot guarantee full consistency. However, the information in this publication is reviewed regularly and any necessary corrections are included in subsequent editions.

Table of contents

1	Introduction.....	5
1.1	S7-1500R/H Documentation Guide.....	6
1.1.1	Information classes S7-1500R/H.....	6
1.1.2	SIMATIC Technical Documentation.....	8
2	Industrial cybersecurity.....	10
2.1	Introduction to industrial cybersecurity.....	10
2.2	Cybersecurity information.....	10
2.3	Cybersecurity-relevant information.....	11
3	Product overview.....	13
3.1	New functions.....	13
3.2	Configuration and operating principle.....	18
3.3	Hardware properties.....	20
3.4	Firmware functions.....	22
3.5	Operator controls and display elements.....	25
3.5.1	Front view of the CPU with closed front panel.....	25
3.5.2	Front view of the CPU without front panel and bottom view.....	27
3.5.3	Rear view of the CPU.....	28
3.6	Operating mode buttons.....	29
4	Connecting.....	30
4.1	Terminal assignment.....	30
5	Interrupts, diagnostics, error messages and system events.....	34
5.1	Status and error display of the CPU.....	34
6	Technical specifications.....	39
A	Dimension drawing.....	50

Introduction

Purpose of the documentation

This manual supplements the system manual of the S7-1500R/H redundant system and the function manuals. This manual contains a description of the module-specific information. The system-related functions are described in the system manual. All system-spanning functions are described in the function manuals.

The information provided in this manual and the system manual enables you to commission the CPU 1515R-2 PN.

Conventions

STEP 7: In this documentation, "STEP 7" is used as a synonym for all versions of the configuration and programming software "STEP 7 (TIA Portal)".

Please also observe notes marked as follows:

NOTE

A note contains important information on the product described in the documentation, on the handling of the product or on the section of the documentation to which particular attention should be paid.

Recycling and disposal

For environmentally friendly recycling and disposal of your old equipment, contact a certified electronic waste disposal company and dispose of the equipment according to the applicable regulations in your country.

Industry Mall

The Industry Mall is the catalog and order system of Siemens AG for automation and drive solutions on the basis of Totally Integrated Automation (TIA) and Totally Integrated Power (TIP).

You can find catalogs for all automation and drive products on the Internet

(<https://mall.industry.siemens.com>).

ID-Link for the digital nameplate



The ID-Link is a globally unique identifier according to IEC 61406-1, which you will find in the future as a QR code on your product.

The figure shows an example of an ID-Link for the CPU 1515R-2 PN.

You can recognize the ID-Link by the frame with a black corner at the bottom right. The ID-Link takes you to the digital nameplate of your product.

Scan the QR code on the product or packaging label with a smartphone camera, barcode scanner, or reader app. Call the ID-Link.

In the digital nameplate, you will find product data, manuals, declarations of conformity, certificates, and other helpful information about your product.

1.1 S7-1500R/H Documentation Guide

1.1.1 Information classes S7-1500R/H



The documentation for the redundant S7-1500R/H system is arranged into three areas. This arrangement enables you to access the specific content you require. You can download the documentation free of charge from the Internet (<https://support.industry.siemens.com/cs/ww/en/view/109742691>).

Basic information



The System Manual and Getting Started describe in detail the configuration, installation, wiring and commissioning of the redundant S7-1500R/H system.

The STEP 7 online help supports you in the configuration and programming.

Examples:

- Getting Started S7-1500R/H
- System manual S7-1500R/H
- Online help TIA Portal

Device information



Equipment manuals contain a compact description of the module-specific information, such as properties, wiring diagrams, characteristics and technical specifications.

Examples:

- Equipment Manuals CPUs
- Equipment Manuals Power Supply Modules

General information



The function manuals contain detailed descriptions on general topics relating to the redundant S7-1500R/H system.

Examples:

- Function Manual Diagnostics
- Function Manual Communication
- Function manual Structure and Use of the CPU Memory
- Function Manual Cycle and Response Times
- PROFINET Function Manual

Product Information

Changes and supplements to the manuals are documented in a Product Information. The Product Information takes precedence over the device and system manuals.

You can find the latest Product Information on the redundant S7-1500R/H system on the Internet. (<https://support.industry.siemens.com/cs/ww/en/view/109742691>)

Manual Collection S7-1500/ET 200MP

The Manual Collection S7-1500/ET 200MP contains the complete documentation on the redundant S7-1500R/H system gathered together in one file.

You can find the Manual Collection on the Internet.

(<https://support.industry.siemens.com/cs/ww/en/view/86140384>)

SIMATIC S7-1500 comparison list for programming languages

The comparison list contains an overview of which instructions and functions you can use for which controller families.

You can find the comparison list on the Internet.

(<https://support.industry.siemens.com/cs/ww/en/view/86630375>)

1.1.2 SIMATIC Technical Documentation

Additional SIMATIC documents will complete your information. You can find these documents and their use at the following links and QR codes.

The Industry Online Support gives you the option to get information on all topics. Application examples support you in solving your automation tasks.

Overview of the SIMATIC Technical Documentation

Here you will find an overview of the SIMATIC documentation available in Siemens Industry Online Support:



Industry Online Support International

<https://support.industry.siemens.com/cs/ww/en/view/109742705>

Watch this short video to find out where you can find the overview directly in Siemens Industry Online Support and how to use Siemens Industry Online Support on your mobile device:



Quick introduction to the technical documentation of automation products per video <https://support.industry.siemens.com/cs/us/en/view/109780491>



YouTube video: Siemens Automation Products - Technical Documentation at a Glance <https://youtu.be/TwLSxxRQsA>

Retention of the documentation

Retain the documentation for later use.

For documentation provided in digital form:

1. Download the associated documentation after receiving your product and before initial installation/commissioning. Use the following download options:
 - Industry Online Support International: <https://support.industry.siemens.com>
The article number is used to assign the documentation to the product. The article number is specified on the product and on the packaging label. Products with new, non-compatible functions are provided with a new article number and documentation.
 - ID link:
Your product may have an ID link. The ID link is a QR code with a frame and a black frame corner at the bottom right. The ID link takes you to the digital nameplate of your product. Scan the QR code on the product or on the packaging label with a smartphone camera, barcode scanner, or reader app. Call up the ID link.
2. Retain this version of the documentation.

Updating the documentation

The documentation of the product is updated in digital form. In particular in the case of function extensions, the new performance features are provided in an updated version.

1. Download the current version as described above via the Industry Online Support or the ID link.
2. Also retain this version of the documentation.

mySupport

With "mySupport" you can get the most out of your Industry Online Support.

Registration	You must register once to use the full functionality of "mySupport". After registration, you can create filters, favorites and tabs in your personal workspace.
Support requests	Your data is already filled out in support requests, and you can get an overview of your current requests at any time.
Documentation	In the Documentation area you can build your personal library.
Favorites	You can use the "Add to mySupport favorites" to flag especially interesting or frequently needed content. Under "Favorites", you will find a list of your flagged entries.
Recently viewed articles	The most recently viewed pages in mySupport are available under "Recently viewed articles".
CAX data	The CAX data area gives you access to the latest product data for your CAX or CAe system. You configure your own download package with a few clicks: <ul style="list-style-type: none"> • Product images, 2D dimension drawings, 3D models, internal circuit diagrams, EPLAN macro files • Manuals, characteristics, operating manuals, certificates • Product master data

You can find "mySupport" on the Internet. (<https://support.industry.siemens.com/My/ww/en>)

Application examples

The application examples support you with various tools and examples for solving your automation tasks. Solutions are shown in interplay with multiple components in the system - separated from the focus on individual products.

You can find the application examples on the Internet.
(<https://support.industry.siemens.com/cs/ww/en/ps/ae>)

Industrial cybersecurity

2.1 Introduction to industrial cybersecurity

Due to the digitalization and increasing networking of machines and industrial plants, the risk of cyber attacks is also growing. Appropriate protective measures are therefore mandatory, particularly in the case of critical infrastructure facilities.

Refer to the System Manual (<https://support.industry.siemens.com/cs/us/en/view/109754833>) for general information and measures regarding industrial cybersecurity.

This section provides an overview of security-related information pertaining to your SIMATIC device.

NOTE

Security-relevant changes to software or devices are documented in the section "New functions ([Page 13](#))".

2.2 Cybersecurity information

Siemens provides products and solutions with industrial cybersecurity functions that support the secure operation of plants, systems, machines, and networks.

In order to protect plants, systems, machines, and networks against cyber threats, it is necessary to implement – and continuously maintain – a holistic, state-of-the-art industrial cybersecurity concept. Siemens' products and solutions constitute one element of such a concept.

Customers are responsible for preventing unauthorized access to their plants, systems, machines and networks. Such systems, machines and components should only be connected to an enterprise network or the internet if and to the extent such a connection is necessary and only when appropriate security measures (e.g. firewalls and/or network segmentation) are in place.

For more information on protective industrial cybersecurity measures for implementation, please visit (<https://www.siemens.com/global/en/products/automation/topic-areas/industrial-cybersecurity.html>).

Siemens' products and solutions undergo continuous development to make them more secure. Siemens strongly recommends that product updates are applied as soon as they are available and that the latest product versions are used. Use of product versions that are no longer supported, and failure to apply the latest updates may increase customers' exposure to cyber threats.

To stay informed about product updates at all times, subscribe to the Siemens Industrial Cybersecurity RSS Feed under (<https://new.siemens.com/global/en/products/services/cert.html>).

2.3 Cybersecurity-relevant information

Note all cybersecurity-relevant information.

Topics with cybersecurity-relevant information	Reference
Operational application environment and security assumptions	
Requirements for the operational application environment of the system and security assumptions	This section is found in the System Manual (https://support.industry.siemens.com/cs/us/en/view/109754833).
Security properties of the product	
<p>Access protection</p> <p>Physical protection:</p> <ul style="list-style-type: none"> You can protect the CPU against unauthorized access by locking the front flap. <p>Password protection</p> <p>You can also protect the CPU with a password.</p> <p>Password categories:</p> <ul style="list-style-type: none"> Password to protect confidential configuration data Password in the context of user management (UMAC) Password for display 	<p>Information on locking and on password protection can be found in this Equipment Manual in the section Operator controls and display elements (Page 25).</p> <p>Also note the information on the topic of access protection in the Protection section of the System Manual (https://support.industry.siemens.com/cs/us/en/view/109754833).</p>
<p>Integrated protection functions</p> <ul style="list-style-type: none"> The CPUs have integrated protection functions. 	<p>For information on the protection functions, refer to the "Overview of protection functions" section of the System Manual (https://support.industry.siemens.com/cs/us/en/view/109754833).</p>
<p>PROFINET Security Class 1</p> <ul style="list-style-type: none"> The device supports PROFINET Security Class 1. With the introduction of PROFINET Security Class 1, additional security settings have been integrated into the PROFINET communication. 	<p>Detailed information about PROFINET Security Class 1 and the additional security settings can be found in the PROFINET with STEP 7 Function Manual (https://support.industry.siemens.com/cs/us/en/view/49948856).</p>
Reading out and verifying signatures	You can find detailed information on reading and verifying signatures in the STEP 7 online help (TIA Portal).
Supported Ethernet services	<p>Information about supported services can be found in the section Technical specifications (Page 39).</p> <p>You can find detailed information on the supported Ethernet services in the Communication Function Manual (https://support.industry.siemens.com/cs/us/en/view/59192925).</p>
Interfaces, ports, protocols and services	
<p>Information on the following is security related:</p> <ul style="list-style-type: none"> Communications layer and communication role Default states Enabling/disabling ports and services 	<p>You can find detailed information on these topics in the Communication Function Manual (https://support.industry.siemens.com/cs/us/en/view/59192925).</p>
Secure operation	
Corrective measures for known risks	<p>Corrective measures for known risks are announced on the Siemens ProductCERT (https://siemens.com/productcert) Web page.</p> <p>For more information on SIEMENS ProductCERT, refer to the System Manual (https://support.industry.siemens.com/cs/us/en/view/109754833).</p>

2.3 Cybersecurity-relevant information

Topics with cybersecurity-relevant information	Reference
Security checks	Application-specific security measures such as cyclic checks of the configuration via checksums are described in the System Manual (https://support.industry.siemens.com/cs/us/en/view/109754833).
Recording Security events	Information on recording security events can be found in the "Safe operation of CPUs" section of the System Manual (https://support.industry.siemens.com/cs/us/en/view/109754833).
Secure decommissioning Products that contain security-relevant data must be securely decommissioned before disposal or resale.	Information on secure decommissioning can be found in the "Safe operation of the system" section of the System Manual (https://support.industry.siemens.com/cs/us/en/view/109754833).

Product overview

3.1 New functions

This section contains an overview of the most important new firmware functions of the CPU compared with the predecessor version CPU (V3.0).

New functions of the CPU in firmware version V3.1

New functions	Customer benefits	Where can I find information?
Power supply modules	System power supplies (PS) supply the internal electronics of the S7-1500R/H modules with power via the backplane bus. The following system power supply modules are supported: <ul style="list-style-type: none"> PS 25W 24V DC PS 60W 24/48/60V DC PS 60W 120/230V AC/DC 	S7-1500R/H System Manual (https://support.industry.siemens.com/cs/ww/en/view/109754833)
Communications processors CPs	The CPs relieve the R/H CPUs from communication tasks and enable further communication connections: <ul style="list-style-type: none"> To the automation level To the IT world The redundant design of the CPs (per R/H CPU) increases the availability of the redundant system for communication tasks. From FW version V3.1 the S7-1500R/H redundant system supports the CP 1543-1 communications processor: <ul style="list-style-type: none"> S7-1500R: max. 2 CPs per R-CPU 	<ul style="list-style-type: none"> S7-1500R/H System Manual (https://support.industry.siemens.com/cs/ww/en/view/109754833) CP 1543-1 (https://support.industry.siemens.com/cs/de/de/view/67700710/en) operating instructions
IE/PB LINK HA	The IE/PB LINK HA connects PROFINET IO and PROFIBUS DP as a gateway. This enables the IE/PB LINK HA to access all DP devices connected to the lower-level PROFIBUS network. The IE/PB LINK HA supports up to 64 DP devices. In the redundant S7-1500R/H system, the IE/PB LINK HA is integrated into the PROFINET network as an S2 device.	<ul style="list-style-type: none"> S7-1500R/H System Manual (https://support.industry.siemens.com/cs/ww/en/view/109754833) IE/PB LINK (https://support.industry.siemens.com/cs/de/de/view/10974428-0/en) operating instructions
Web API of the Web server (Application Programming Interface)	As of firmware version V3.1, the S7-1500R/H redundant system supports the Web API of the Web server. An overview of which mechanisms and methods support the R/H CPUs can be found in the Web server Function Manual.	Web server (https://support.industry.siemens.com/cs/de/en/view/59193560) Function Manual

3.1 New functions

New functions	Customer benefits	Where can I find information?
Data exchange via OPC UA as server	As of firmware version V3.1, the S7-1500R/H redundant system supports data exchange as an OPC UA server. An OPC UA server provides information within a network, e.g. relating to the CPU, the OPC UA server itself, the data, and the data types. An OPC UA client accesses this information.	<ul style="list-style-type: none"> • S7-1500R/H System Manual (https://support.industry.siemens.com/cs/ww/en/view/109754833) • Communication (https://support.industry.siemens.com/cs/ww/en/view/59192925) Function Manual
Data logging	As of firmware version V3.1 the S7-1500R/H redundant system supports data logging. With data logging, you can save process values from the user program in a file known as the data log. The data logs are saved on the SIMATIC Memory Card in CSV format and stored in the "DataLogs" directory. You can create and modify data logs using the asynchronous "data logging" instructions. Data logs from the S7-1500R/H are loaded via the Web API of the Web server.	Structure and use of the CPU memory (https://support.industry.siemens.com/cs/ww/en/view/59193101) Function Manual
User files	As of firmware version V3.1, the S7-1500R/H redundant system supports user files. User files are user-specific files that are stored on the SIMATIC Memory Card and in the "UserFiles" directory. You can read and write user files via the asynchronous "File handling" instructions (FileReadC, FileWriteC) or via the Web API of the Web server.	STEP 7 online help
Local user management	As of TIA Portal version V19 and FW version V3.1, R/H CPUs have improved management of users, roles, and CPU function rights (User Management & Access Control, UMAC). As of the above-mentioned versions, you can manage all project users in the editor, with their rights (e.g. access rights) for all CPUs in the project for users and roles of the project in the TIA Portal.	S7-1500R/H System Manual
Additional new functions	You can find an overview in the System Manual.	S7-1500R/H System Manual (https://support.industry.siemens.com/cs/ww/en/view/109754833)

New functions of the CPU in firmware version V3.0

New functions	Customer benefits	Where can I find information?
Integrated work memory for program and data expanded	The expansion of the integrated work memory allows you to implement larger and more extensive applications with the CPUs.	Section Technical specifications (Page 39)
Data block functions	As of FW version V3.0, the instructions for the data block functions are supported: <ul style="list-style-type: none"> • CREATE_DB (create data block) • READ_DBL (read from data block in the load memory) • WRIT_DBL (write to data block in the load memory) • DELETE_DB (delete data block) 	STEP 7 online help
Network Management Protocol SNMP: A simple configuration option is available for use of SNMP services. For new configurations, this is disabled by default in accordance with "Security-by-Default".	Can be enabled/disabled in the CPU properties. Community strings can be configured.	Communication Function Manual (https://support.industry.siemens.com/cs/ww/en/view/59192925)
Trace: The S7-1500 CPU supports up to 64 configured signals per trace.	Number of configurable signals per trace extended	Using the Trace and Logic Analyzer Function Manual (http://support.automation.siemens.com/WW/view/en/64897128)

New functions of the CPU in firmware version V2.9

New functions	Customer benefits	Where can I find information?
Influence switchover time of switched S1 devices	As of FW version V2.9, you can influence the switchover time between disconnection and return of switched S1 devices after a failure/STOP of the primary CPU. This function offers the following advantages: <ul style="list-style-type: none"> • Optimization of the switchover time between disconnection and return of switched S1 devices 	PROFINET Function Manual (http://support.automation.siemens.com/WW/view/en/49948856)
MRP interconnection	The MRP interconnection procedure is an extension of MRP. MRP interconnection enables the redundant coupling of 2 or more rings with MRP in PROFINET networks. MRP interconnection offers the following advantages: <ul style="list-style-type: none"> • When setting up redundant network topologies, there is no limitation to the maximum number of devices of 50 devices in a ring. • Monitoring of larger topologies with ring redundancy. 	

3.1 New functions

New functions	Customer benefits	Where can I find information?
Simulation of R/H-CPU's	<p>PLCSIM Advanced V4.0 supports simulation of R/H-CPU's</p> <ul style="list-style-type: none"> Virtual commissioning of machines with R/H-CPU's in a system Automatic testing of the STEP 7 user program <p>The simulation offers the following advantages:</p> <ul style="list-style-type: none"> Early error detection and risk minimization Reduced response times No hardware costs 	<p>S7-PLCSIM Advanced Function Manual https://support.industry.siemens.com/cs/ww/en/view/109773484</p>
OB 72 (CPU redundancy error)	<p>As of FW version V2.9, the operating system calls OB 72 on further events:</p> <ul style="list-style-type: none"> The R/H-system has entered RUN-Redundant system state and the synchronization of the two R/H-CPU's is possible redundantly. The R/H-system has entered RUN-Redundant system state, but the synchronization of the two R/H-CPU's is not possible redundantly. The R/H-system is still in RUN-Redundant system state and the synchronization of the two R/H-CPU's is possible redundantly now or again. The R/H-system is still in RUN-Redundant system state, but the synchronization of the two R/H-CPU's is no longer possible redundantly. 	<p>S7-1500R/H System Manual https://support.industry.siemens.com/cs/ww/en/view/109754833</p>
"RH_CTRL" instruction	<p>As of FW version V2.9, the "RH_CTRL" instruction supports additional functions:</p> <ul style="list-style-type: none"> Request SYNCUP Switch primary CPU to STOP mode (only in RUN-Redundant system state) Switch backup CPU to STOP mode 	
Instructions for recipe phases	<p>As of FW version V2.9, the instructions for recipe phases supports:</p> <ul style="list-style-type: none"> RecipeExport (export recipe) RecipeImport (import recipe) 	<p>Online help for STEP 7</p>
Technology objects TO_BasicPos and SSI_Absolute_Encoder	<p>Technology object "TO_BasicPos" You use the "TO_BasicPos" instruction to cyclically control a SINAMICS drive with the technology for SINAMICS S/G/V basic positioners.</p> <p>Technology object SSI_Absolute_Encoder You use the "SSI_Absolute_Encoder" instruction to control position detection and measuring functions of the TM PosInput technology module via the user program.</p>	

New functions of the CPU in firmware version V2.8

New functions	Customer benefits	Where can I find information?
Download modified user program in RUN-Redundant system state	You can download a modified user program into the R/H CPUs in the RUN-Redundant system state. Advantage: The redundant system will remain consistently in the RUN-Redundant system state during the change to the user program. The system state will not switch to RUN-Rolo or SYNCUP.	S7-1500R/H System Manual (https://support.industry.siemens.com/cs/ww/en/view/109754833)
Backing up the configuration of the S7-1500R/H redundant system in runtime	You do not have to interrupt the process during a backup while the plant is running. Uninterrupted plant operation avoids high restart and material costs.	
Switched S1 device	The "Switched S1 device" function of the CPU enables operation of standard IO devices in the S7-1500R/H redundant system.	
Testing with breakpoints	When testing with breakpoints, you run a program from breakpoint to breakpoint in the STARTUP (startup OB) or RUN-Solo system state. Testing with breakpoints provides you with the following advantages: <ul style="list-style-type: none"> • Testing SCL and STL program code with the help of breakpoints • Localization of logic errors step by step • Simple and quick analysis of complex programs prior to actual commissioning • Recording of current values within individual executed loops • Using breakpoints for program validation is also possible in SCL or STL networks within LAD/FBD blocks. 	
PID controller	PID controllers are built into all R/H-CPU as standard. PID controllers measure the actual value of a physical variable, for example, temperature or pressure, and compare the actual value with the setpoint. Based on the resulting error signal, the controller calculates a manipulated variable that causes the process value to reach the setpoint as quickly and stably as possible. The PID controllers offer you the following advantages: <ul style="list-style-type: none"> • Simple configuration and programming through integrated editors and blocks • Simple simulation, visualization, commissioning and operation via PG and HMI • Automatic calculation of the control parameters and tuning during operation • No additional hardware and software required 	<ul style="list-style-type: none"> • S7-1500R/H System Manual (https://support.industry.siemens.com/cs/ww/en/view/109754833) • PID control Function Manual (https://support.industry.siemens.com/cs/ww/en/view/108210036)
Alarms in the user program	Alarms enable you to display events from process execution in the S7-1500R/H redundant system and to quickly identify, accurately locate, and correct errors.	Diagnostics Function Manual (https://support.industry.siemens.com/cs/ww/en/view/59192926)

Additional information

You can find an overview of all new functions, improvements and revisions in the respective firmware versions on the Internet

(<https://support.industry.siemens.com/cs/ww/en/view/109478459>).

3.2 Configuration and operating principle

Structure

The S7-1500R redundant system consists of the following components:

- Two CPUs of the type CPU 1515R-2 PN
- Two SIMATIC Memory Cards
- PROFINET cable (redundancy connections, PROFINET ring)
- IO devices
- Optional load current supply
- Optional system power supply (only via U-type connector)
- Optional communications processors CP 1543-1 (only via U-type connector)

You mount the CPUs on a common mounting rail or spatially separated on two separate mounting rails. You connect the two CPUs and the IO devices in a PROFINET ring via the PROFINET cable.

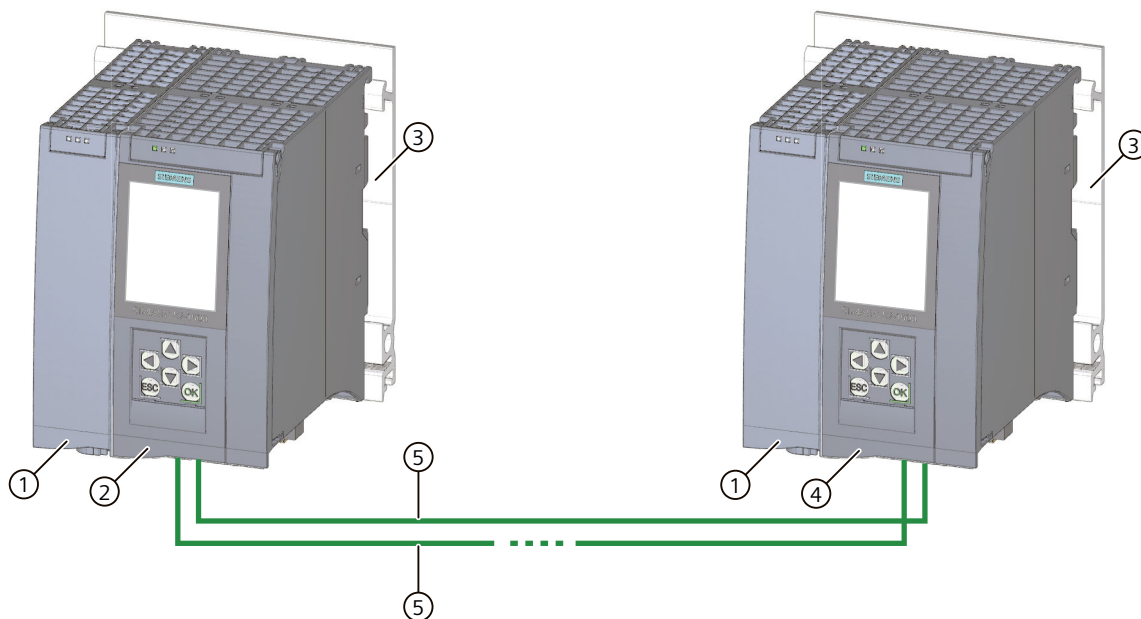

- ① Optional load current supply
- ② First CPU
- ③ Mounting rail with integrated DIN rail profile
- ④ Second CPU
- ⑤ PROFINET cable (redundancy connections, PROFINET ring)

Figure 3-1 Configuration example for S7-1500R

NOTE**Standard rail adapter**

You mount the CPUs on a standardized 35 mm rail using the standard rail adapter.

You will find information on mounting the standard rail adapter in the S7-1500R/H redundant system (<https://support.industry.siemens.com/cs/ww/en/view/109754833>) System Manual.

Principle of operation

One of the two CPUs in the redundant system takes on the role of CPU for process control (primary CPU). The other CPU takes on the role of the following CPU (backup CPU). The assigned role of the CPUs can change during operation. Synchronization of all relevant data between primary CPU and backup CPU ensures fast switching between CPUs in the event of a primary CPU failure. If the primary CPU fails, the backup CPU retains control of the process as the new primary CPU at the point of interruption.

The redundancy connections are the PROFINET ring with MRP. The CPUs are synchronized via a PROFINET ring.

Additional information

You can find a detailed description of the operation and design of the CPUs in the S7-1500R/H redundant system System Manual.

3.3 Hardware properties

Article number

6ES7515-2RN03-0AB0

View of the module

The figure below shows the CPU 1515R-2 PN.



Figure 3-2 CPU 1515R-2 PN

NOTE

Protective film

Note that there is a removable protective foil on the display when the CPUs are delivered.

Properties

CPU 1515R-2 PN has the following technical properties:

Property	Description	Additional information
CPU display	All CPUs of the redundant system S7 1500R/H have a display with plain text information. The display provides you with diagnostic messages as well as information about the article number, the firmware version and the serial number of the CPU. You can also view and assign the IP addresses, the PROFINET device name and the redundancy ID of the	<ul style="list-style-type: none"> S7-1500R/H redundant system (https://support.industry.siemens.com/cs/ww/en/view/109754833) system manual

Property	Description	Additional information
	<p>CPU. The system IP address can be viewed via STEP 7 but not in the display.</p> <p>In addition to the functions listed here, a large number of other functions are available on the display. These additional functions are described in the SIMATIC S7 1500 Display Simulator.</p>	<ul style="list-style-type: none"> SIMATIC S7-1500 Display Simulator or (https://support.industry.siemens.com/cs/ww/en/view/109761758)
Supply voltage	The 24 V DC supply voltage is fed via a 4-pin plug located on the front of the CPU.	<ul style="list-style-type: none"> Section Connecting (Page 30) S7-1500R/H redundant system (https://support.industry.siemens.com/cs/ww/en/view/109754833) system manual
PROFINET IO		
PROFINET IO interface (X1 P1R and X1 P2R)	<p>The CPU has an X1 interface with two ports (X1 P1R and X1 P2R).</p> <ul style="list-style-type: none"> You use the PROFINET IO interface X1 (default setting P1R) to configure the PROFINET ring with the two CPUs and the IO devices. You use the PROFINET IO interface X1 (default setting P2R) to establish the connection between the two R-CPU's within the PROFINET ring. <p>In the PROFINET ring, the synchronization frames between the CPUs are transmitted via the following connections:</p> <ul style="list-style-type: none"> The direct connection (X1 P2R) The indirect connection (X1 P1R) via the IO devices <ul style="list-style-type: none"> The interface supports PROFINET IO RT (Real-Time) and PROFINET basic functionality. <p>Basic PROFINET functionality comprises:</p> <ul style="list-style-type: none"> HMI communication Communication with the configuration system Communication with a higher-level network (backbone, router, Internet) Communication with another machine or automation cell 	<ul style="list-style-type: none"> S7-1500R/H redundant system (https://support.industry.siemens.com/cs/ww/en/view/109754833) system manual Function manual PROFINET (https://support.industry.siemens.com/cs/ww/en/view/49948856)
PROFINET interface (X2 P1)	The CPU has an X2 interface with one port (X2 P1). The interface supports PROFINET basic functionality.	
Operation of the CPUs as IO controllers	<p>IO controller:</p> <p>As IO controllers the CPUs address the following configured IO devices:</p> <ul style="list-style-type: none"> IO devices with S2 system redundancy within the PROFINET ring IO devices with S2 system redundancy that are decoupled from the PROFINET ring via a switch Standard IO devices (switched S1 devices) <p>Standard IO devices usually do not support H-Sync Forwarding.</p> <p>To avoid a cycle time increase when the PROFINET ring is interrupted, integrate the standard IO devices behind a switch and not in the PROFINET ring.</p>	

H-Sync Forwarding

H-Sync Forwarding enables a PROFINET device with MRP to forward synchronization data (synchronization frames) of an S7-1500R redundant system only within the PROFINET ring. In addition, H-Sync Forwarding forwards the synchronization data even during reconfiguration of the PROFINET ring. H-Sync Forwarding avoids a cycle time increase if the PROFINET ring is interrupted.

NOTE

Support of H-Sync Forwarding

The technical specifications typically state whether a PROFINET device supports H-Sync Forwarding.

The GSD file will also indicate whether the device supports H-Sync Forwarding. The device supports H-Sync Forwarding when the "ApplicationClass" attribute contains the "HighAvailability" token.

You will find more information on H-Sync Forwarding in the system manual S7-1500R/H redundant system (<https://support.industry.siemens.com/cs/ww/en/view/109754833>).

Accessories

You can find information on the topic of "Accessories/spare parts" in the system manual for S7-1500R/H redundant system (<https://support.industry.siemens.com/cs/ww/en/view/109754833>).

3.4 Firmware functions

Functions

CPU 1515R-2 PN supports the following firmware functions:

Function	Description	Additional information
CPU redundancy	There are two duplicate CPUs that synchronize their data via redundancy connections within a PROFINET ring. If one of the CPUs fails, the other CPU retains control of the process.	S7-1500R/H redundant system (https://support.industry.siemens.com/cs/ww/en/view/109754833) System Manual
Integrated system diagnostics	The system automatically generates the messages for the system diagnostics and outputs these messages via a programming device/PC, HMI device or the integrated display. System diagnostics information is also available when the CPUs are in operating state STOP.	Diagnostics (https://support.industry.siemens.com/cs/ww/en/view/59192926) Function Manual
Web API of the Web server (Application Programming Interface)	An overview of which mechanisms and methods support the CPU can be found in the Web server Function Manual.	Web server (https://support.industry.siemens.com/cs/de/en/view/59193560) Function Manual

Function	Description	Additional information
Integrated trace functionality	Trace functionality supports you in troubleshooting and/or optimizing the user program. You record device tags and evaluate the recordings with the trace and logic analyzer function. Tags are, for example, drive parameters or system and user tags of a CPU. Trace and logic analyzer functions are suitable for monitoring highly dynamic processes. Note: Note that the S7-1500R/H redundant system supports recording of measurements. However, saving the measurements to the SIMATIC Memory Card is not supported.	Using the trace and logic analyzer function https://support.industry.siemens.com/cs/ww/en/view/64897128 Function Manual
OPC UA as server	An OPC UA server provides information within a network, e.g. relating to the CPU, the OPC UA server itself, the data, and the data types. An OPC UA client accesses this information.	Communication https://support.industry.siemens.com/cs/ww/en/view/59192925 Function Manual
PROFINET IO		
System redundancy S2	IO-Devices with S2 system redundancy enable uninterrupted operation during a primary backup switchover. If the role of the CPUs changes, the new primary CPU takes over the PROFINET IO communication.	<ul style="list-style-type: none"> S7-1500R/H redundant system (https://support.industry.siemens.com/cs/ww/en/view/109754833) System Manual PROFINET (http://support.automation.siemens.com/WW/view/en/49948856) Function Manual
Switched S1 device	The switched S1 device function of the CPU enables operation of standard IO devices in the S7-1500R/H redundant system.	S7-1500R/H redundant system (https://support.industry.siemens.com/cs/ww/en/view/109754833) System Manual
RT (real time)	RT prioritizes PROFINET IO frames over standard frames. This ensures the required determinism in the automation technology. In this process the data is transferred via prioritized Ethernet frames.	PROFINET (http://support.automation.siemens.com/WW/view/en/49948856) Function Manual
MRP (Media Redundancy Protocol)	The Media Redundancy Protocol enables the configuration of redundant networks. Redundant transmission links (ring topology) ensure that an alternative communication path is made available if a transmission link fails. Within the PROFINET ring, the R-CPU assumes the role of the MRP Manager following appropriate project configuration and all other devices in the ring assume the role of the MRP clients.	
MRP interconnection	The process MRP interconnection is an enhancement of MRP and allows redundant coupling of two or more rings with MRP in PROFINET networks. MRP interconnection is like MRP - specified in the standard IEC 62439-2 (Edition 3).	

3.4 Firmware functions

Function	Description	Additional information
PROFIenergy	PROFIenergy is a PROFINET-based data interface for switching off consumers centrally and with full coordination during pause times regardless of the manufacturer or device type. Through this, the process should only be provided with the energy that is absolutely required. Most of the energy is saved by the process. The PROFINET device itself only contributes a few watts to the savings potential.	PROFINET (http://support.automation.siemens.com/WW/view/en/49948856) Function Manual
Integrated technology		
Integrated closed-loop control functionality	<ul style="list-style-type: none"> PID Compact (continuous PID controller) PID 3Step (step controller for integrating actuators) PID Temp (temperature controller for heating and cooling with two separate actuators) 	PID control (https://support.industry.siemens.com/cs/ww/en/view/108210036) Function Manual
Controlling, measuring and position detection	<ul style="list-style-type: none"> TO_BasicPos (control of a SINAMICS drive) SSI_Absolute_Encoder (control of position detection and measuring function of the TM PosInput technology module) 	STEP 7 online help
Security Integrated		
Know-how protection	The know-how protection protects user blocks against unauthorized access and modifications.	S7-1500R/H redundant system (https://support.industry.siemens.com/cs/ww/en/view/109754833) System Manual
Local user management (as of FW version V3.1)	Improved management of users, roles, and CPU function rights (User Management & Access Control, UMAC). You can use the local user management in the editor to manage all project users along with their rights (e.g. access rights) for users and roles of the project in the TIA Portal.	
Access protection (up to FW version V3.0)	You can use authorization levels to assign separate rights to different user groups.	
Integrity protection	The CPUs come with an integrity protection function as standard. This helps to detect possible manipulations of the engineering data on the SIMATIC Memory Card or during data transfer between the TIA Portal and the CPU and to check communication from a SIMATIC HMI system to the CPU for possible manipulations of engineering data. The user receives a corresponding message about manipulations of engineering data detected by the integrity protection.	
Password provider	As an alternative to manual password entry, you can link a password provider to STEP 7. A password provider offers the following advantages: <ul style="list-style-type: none"> Convenient handling of passwords. STEP 7 automatically imports the password for the blocks. This saves you time. Optimum block protection because the users do not know the password itself. 	

3.5 Operator controls and display elements

3.5.1 Front view of the CPU with closed front panel

The figure below shows the front view of the CPU 1515R-2 PN.

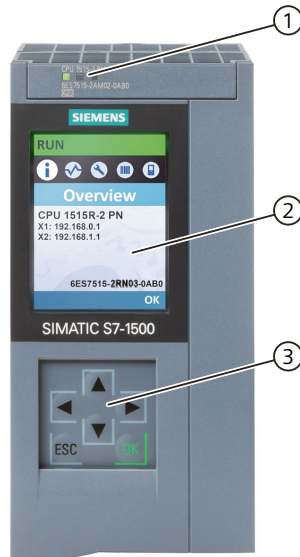

- ① LED displays for the current operating state and diagnostic status of the CPU
- ② Display
- ③ Control keys

Figure 3-3 View of the CPU 1515R-2 PN (with front flap) – front

NOTE

Temperature range for display

To increase its service life, the display switches off at a temperature below the permitted operating temperature of the device. When the display cools down, it automatically switches itself on again. When the display is switched off, the LEDs continue to show the status of the CPUs.

You can find additional information on the temperatures at which the display switches itself on and off in the Technical specifications ([Page 39](#)).

Pulling or plugging the front flap or display

You can pull or plug the front flap or the display during operation.

! WARNING

Personal injury and damage to property may occur

In Zone 2 hazardous areas, personal injury or damage to property can occur if you pull or plug the display of a redundant S7-1500R/H system during operation.

Before you pull or plug the display in Zone 2 hazardous areas, always make sure first that the S7-1500R/H redundant system is de-energized.

Locking the front flap

You can lock the front flap to protect the SIMATIC Memory Card and the mode switch of the CPU against unauthorized access.

You can attach a security seal or a padlock with a shackle diameter of 3 mm to the front flap.

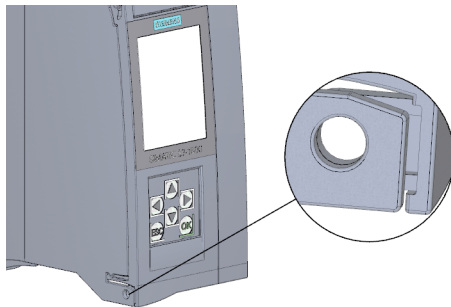

Figure 3-4 Locking latch on the CPU

In addition to the mechanical lock, you can also block access to a password-protected CPU on the display (local lock) and assign a password for the display. You can find more information on the display, the configurable protection levels and the local lock in the S7-1500R/H redundant system System Manual.

Reference

You can find detailed information on the individual display options, a training course and a simulation of the available menu commands in the SIMATIC S7-1500 Display Simulator (<https://support.industry.siemens.com/cs/ww/en/view/109761758>).

See also

S7-1500R/H Redundant System
(<https://support.industry.siemens.com/cs/ww/en/view/109754833>)

3.5.2 Front view of the CPU without front panel and bottom view

The figure below shows the operator controls and connection elements of the CPU 1515R-2 PN.

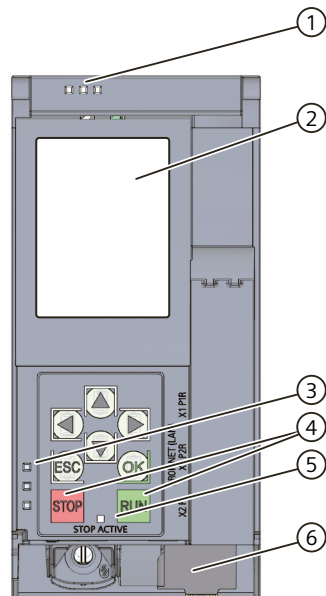

- ① LED displays for the current operating state and diagnostic status of the CPU
- ② Display
- ③ LED displays for the PROFINET interface
- ④ STOP and RUN operating mode buttons
- ⑤ STOP-ACTIVE LED
- ⑥ Connector for power supply

Figure 3-5 View of the CPU 1515R-2 PN (without front flap) – front

NOTE

Removing the display

Only remove the display if it is faulty.

You can find information on removing and replacing the display in the S7-1500R/H redundant system System Manual.

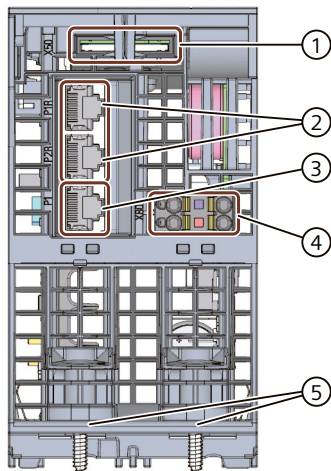

- ① Slot for the SIMATIC Memory Card
- ② PROFINET IO interface (X1) with 2 ports
- ③ PROFINET IO interface (X2) with 1 port
- ④ Connection for supply voltage
- ⑤ Fastening screw

Figure 3-6 View of the CPU 1515R-2 PN – bottom

3.5.3 Rear view of the CPU

The figure below shows the connection elements on the rear of the CPU 1515R-2 PN.

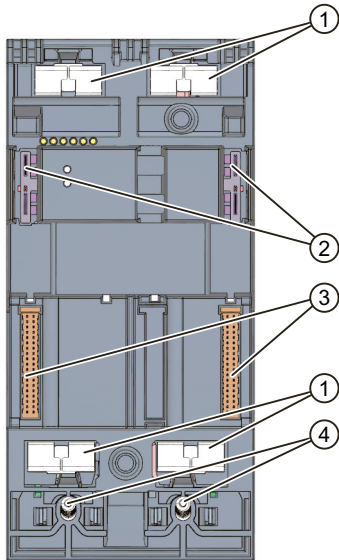

- ① Shield contact surfaces
- ② Plug-in connection for power supply
- ③ Plug-in connection for backplane bus
- ④ Fixing screws

Figure 3-7 View of the CPU 1515R-2 PN - rear

3.6 Operating mode buttons

You use the operating mode buttons to:

- Request a change to a specific operating state
- Disable or enable the change of a specific operating state
(If, for example, the STOP mode button is active, you cannot switch the CPU to RUN via a communication task configured in the TIA Portal or via the display)

The following table shows the meaning of the corresponding operation of the operating mode buttons.

Table 3-1 Meaning of the operating mode buttons

Operation of the operating mode buttons	Meaning	Explanation
RUN	RUN mode	The CPU has permission to go to RUN.
STOP	STOP mode	The CPU does not have permission to go to RUN.
<ol style="list-style-type: none"> 1. Press the STOP operating mode button. Result: The RUN/STOP LED lights up yellow. 2. Press the STOP operating mode button until the RUN/STOP LED lights up for the second time and remains continuously lit (after three seconds). After this, release the button. 3. Press the STOP operating mode button again within the next three seconds. 	Manual memory reset (with inserted SIMATIC Memory Card) or Reset to factory settings (without inserted SIMATIC Memory Card)	The CPU performs a memory reset. or The CPU is reset to factory settings. You can find more information on this in system manual S7-1500R/H redundant system.

Reference

You can find a brief overview of the various operating states and system states in the section Status and error display of the CPU ([Page 34](#)).

You can find a detailed description of the operating states and system states in the system manual for S7-1500R/H redundant system

(<https://support.industry.siemens.com/cs/ww/en/view/109754833>).

Connecting

4.1 Terminal assignment

This section provides information on the terminal assignment of the individual interfaces and the block diagram of the CPU 1515R-2 PN.

24 V DC supply voltage (X80)

The connector for the power supply is plugged in when the CPU ships from the factory. The following table shows the signal names and the descriptions of the pin assignment of the 24 V DC supply voltage.

Table 4-1 Pin assignment 24 V DC supply voltage

View	Signal name ¹⁾		Description
Connector			
	1	1L+	+ 24 V DC of the supply voltage
	2	1M	Ground of the supply voltage
	3	2M	Ground of the supply voltage for loop-through ²⁾
	4	2L+	+ 24 V DC of the supply voltage for loop-through ²⁾

¹⁾ 1L+ and 2L+ as well as 1M and 2M are bridged internally

²⁾ Maximum 10 A permitted

You can find information on the various supply options in the S7-1500R/H redundant system System Manual.

PROFINET interface X1 with 2-port switch (X1 P1R and X1 P2R)

The assignment corresponds to the Ethernet standard for a RJ45 connector.

- When autonegotiation is deactivated, the RJ45 socket is allocated as a switch (MDI-X).
- When autonegotiation is activated, autocrossing is in effect and the RJ45 socket is allocated either as data terminal equipment (MDI) or a switch (MDI-X).

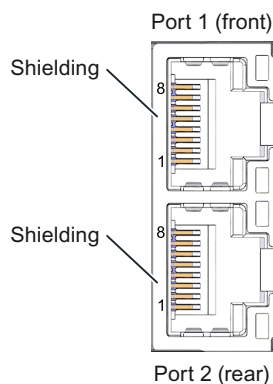

Figure 4-1 PROFINET interface X1 ports

PROFINET interface X2 with 1 port (X2 P1)

The assignment corresponds to the Ethernet standard for a RJ45 connector.

Autocrossing is always active on X2. This means the RJ45 socket is allocated either as data terminal equipment (MDI) or a switch (MDI-X).

Unplugging the PROFINET plug

You need a screwdriver (max. blade width 2.5 mm) to unplug the PROFINET plug.

Removing the display

You can find a description of how to remove and replace the display in the S7-1500R/H redundant system System Manual.

Additional information

You can find more information on the topic of "Connecting the CPU" and on the topic "Accessories/spare parts" in the S7-1500R/H redundant system

(<https://support.industry.siemens.com/cs/ww/en/view/109754833>) System Manual.

Assignment of the MAC addresses

For each CPU, CPU 1515R-2 PN has:

- One PROFINET interface with two ports
- One PROFINET interface with one port

Each of the PROFINET interfaces has a MAC address and each of the PROFINET ports has its own MAC address. There are a total of ten MAC addresses for the two CPUs of the CPU 1515R-2 PN.

The MAC addresses of the PROFINET ports are needed for the LLDP protocol, for example for the neighborhood discovery function.

The number range of the MAC addresses is sequential. The first and last MAC addresses are printed on the rating plate on the right side of each CPU 1515R-2 PN.

The table below shows how the MAC addresses are assigned.

Table 4-2 Assignment of MAC addresses using the example of a single CPU

	Assignment	Labeling
MAC address 1	PROFINET interface X1 (visible in STEP 7 for accessible devices)	<ul style="list-style-type: none"> • Front printed • Right-side printed (start of number range)
MAC address 2	Port X1 P1R (required for LLDP, for example)	---
MAC address 3	Port X1 P2R (required for LLDP, for example)	---
MAC address 4	PROFINET interface X2 (visible in STEP 7 for accessible devices)	<ul style="list-style-type: none"> • Front printed
MAC address 5	Port X2 P1 (required for LLDP, for example)	<ul style="list-style-type: none"> • Right-side printed (end of number range)

Block diagram

The following figure shows the block diagram of the CPU 1515R-2 PN.

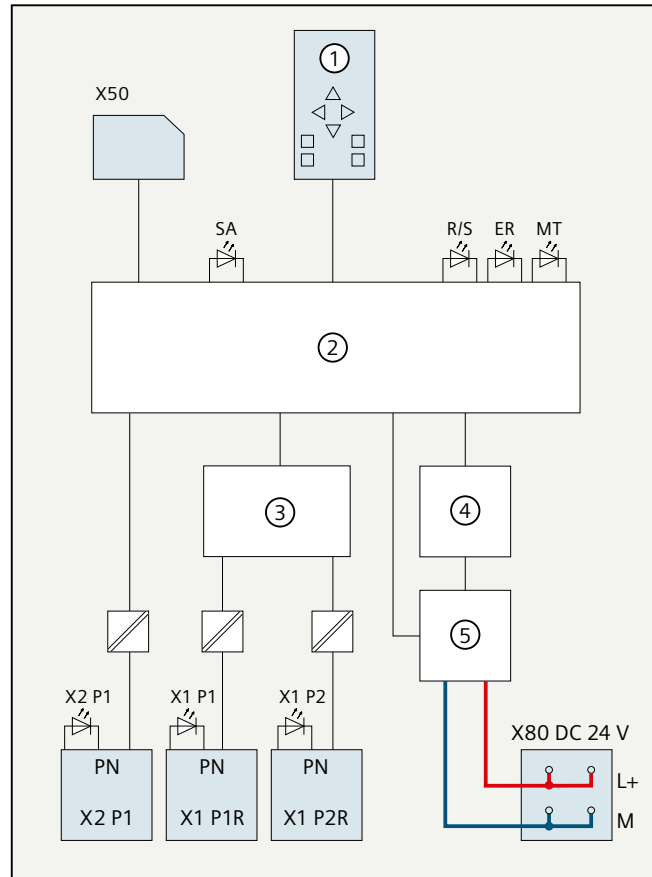

①	CPU with operating buttons and operating mode buttons	X50	SIMATIC Memory Card
②	Electronics	X80 DC 24 V	Infeed of supply voltage V
③	PROFINET 2-port switch	L+	Supply voltage 24 V DC
④	Backplane bus interface	M	Ground
⑤	Internal supply voltage	SA	STOP-ACTIVE LED (yellow)
		R/S	RUN/STOP LED (yellow/green)
		ER	ERROR LED (red)
		MT	MAINT LED (yellow)
		X1 P1, X1 P2, X2 P1	LED Link TX/RX
	PN X1 P1R		PROFINET interface X1 port 1
	PN X1 P2R		PROFINET interface X1 port 2
	PN X2 P1		PROFINET interface X2 port 1

Figure 4-2 Block diagram of the CPU 1515R-2 PN

Interrupts, diagnostics, error messages and system events

5

5.1 Status and error display of the CPU

The LED displays of the CPU are described below.

You can find more detailed information on "Interrupts" in the STEP 7 online help.

You can find additional information on the topic of "Diagnostics" and "System events" in the Diagnostics (<https://support.industry.siemens.com/cs/ww/en/view/59192926>) Function Manual and in the S7-1500R/H redundant system System Manual.

You can find additional information on the topic of "Operating states and system states" as well as various failure scenarios in the S7-1500R/H redundant system System Manual.

LED display

The figure below shows the LED displays of the CPU 1515R-2 PN.

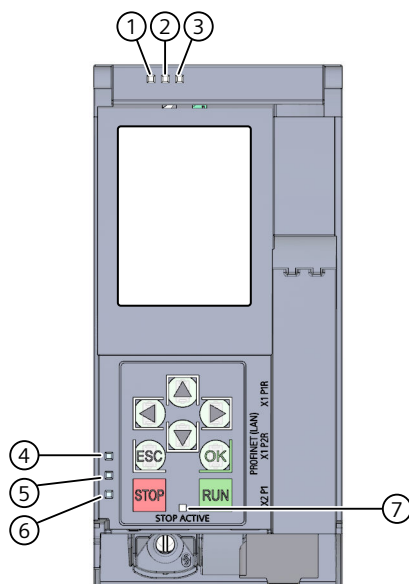

- ① RUN/STOP LED (yellow/green LED)
- ② ERROR LED (red LED)
- ③ MAINT LED (yellow LED)
- ④ LINK RX/TX LED for port X1 P1 (yellow/green LED)
- ⑤ LINK RX/TX LED for port X1 P2 (yellow/green LED)
- ⑥ LINK RX/TX LED for port X2 P1 (yellow/green LED)
- ⑦ STOP-ACTIVE LED

Figure 5-1 LED display of the CPU 1515R-2 PN (without front flap)

LED displays depending on operating states and system states

CPU 1515R-2 PN has the following LEDs for displaying the current operating state and diagnostics status.

- RUN/STOP LED
- ERROR LED
- MAINT LED

The LEDs indicate the operating state of the respective CPU within the redundant system. Operating states describe the behavior of a single CPU at a specific time. The combination of the operating states of the CPUs forms the system state.

The following figure shows the possible operating states of the CPUs and the resulting system states.

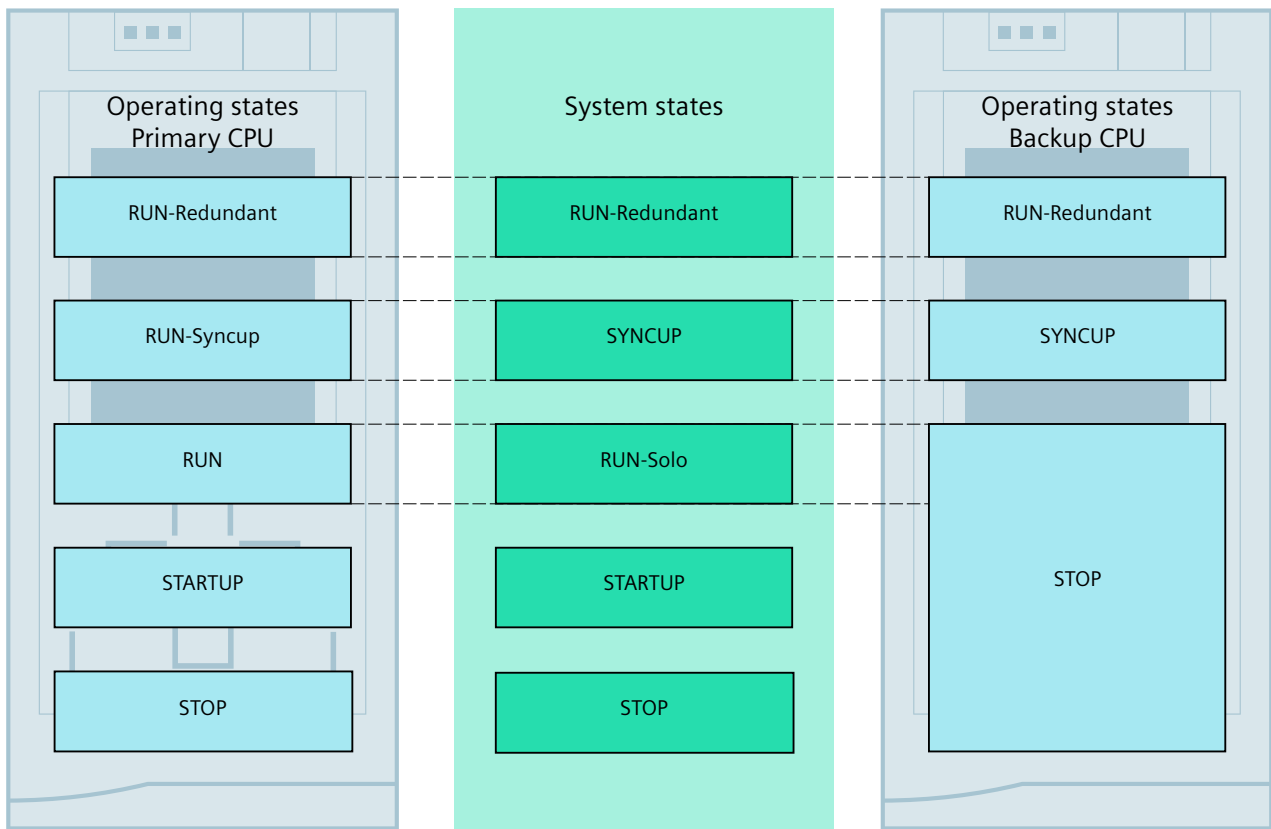

Figure 5-2 Operating states and system states

Meaning of the RUN/STOP, ERROR and MAINT LEDs

CPU 1515R-2 PN has three LEDs for displaying the current operating state and diagnostics status.

NOTE

LED patterns of the redundant system S7 1500R

Note that it is not always possible to:

- Determine the state of the CPU from the signal pattern
- Determine the state of the other CPU from the signal pattern



























The "Meaning" column only shows a possible typical cause.

To investigate the cause of the signal pattern, use the diagnostic buffer and its display via:













- STEP 7
- HMI devices
- Displays of the CPUs

The following table shows the meaning of the various color combinations for the RUN/STOP, ERROR and MAINT LEDs.

Table 5-1 Meaning of the LEDs

RUN/STOP LED	ERROR LED	MAINT LED	Meaning
 LED off	 LED off	 LED off	Missing or insufficient supply voltage on the CPU.
 LED flashes yellow/green	 LED flashes red	 LED flashes yellow	Power on (booting of CPU) LED flashing test
 LED lit yellow	 LED off	 LED lit yellow	CPU is in operating state STOP. Completion of system initialization
 LED flashes yellow	 LED off	 LED lit yellow	CPU executes internal activities in an operating state ≠ RUN-Redundant.
 LED lit yellow	 LED flashes red	 LED flashes yellow	CPU defective Firmware update using SIMATIC Memory Card has failed.
 LED lit yellow	 LED off	 LED flashes yellow	Firmware update successfully completed.
 LED flashes yellow/green	 LED off	 LED lit yellow	The primary CPU is in operating state STARTUP. The backup CPU is in operating state SYNCUP.
 LED flashes yellow	 LED off	 LED off	The CPU performs a warm restart.
 LED lit green	 LED off	 LED lit yellow	Maintenance demanded for the plant. You need to check/replace the affected hardware within a short period of time. The primary CPU is in the RUN or RUN-Syncup operating state.

¹⁾ If there is not enough storage space on a SIMATIC Memory Card or on both SIMATIC Memory Cards in RUN-Redundant, the write function is aborted, and the redundant system continues operation with the original configuration. The redundant system will remain in the RUN-Redundant system state.

RUN/STOP LED	ERROR LED	MAINT LED	Meaning
 LED lit green	 LED off	 LED lit yellow	Active Force job
 LED lit green	 LED off	 LED off	The CPU is in operating state RUN-Redundant. There are no events, requirements, errors, etc.
 LED lit green	 LED flashes red	 LED off	A diagnostic event is pending in operating state RUN-Redundant.
 LED lit green	 LED flashes red	 LED lit yellow	A diagnostic event is present (e.g. failure of an IO device within the PROFINET ring or no access to SIMATIC Memory Card possible ¹⁾) and maintenance is demanded (e.g. interruption of the PROFINET ring).

¹⁾ If there is not enough storage space on a SIMATIC Memory Card or on both SIMATIC Memory Cards in RUN-Redundant, the write function is aborted, and the redundant system continues operation with the original configuration. The redundant system will remain in the RUN-Redundant system state.

NOTE

MAINT LED of the two CPUs

The MAINT LEDs of both CPUs only go out when the following conditions are fulfilled:

- The CPUs are in the RUN-Redundant system state.
- No maintenance is demanded.

NOTE



LED displays in redundant mode

In the RUN-Redundant system state, the LED displays on both CPUs are identical (exception: you are performing an LED flash test on one CPU).

Meaning of LINK RX/TX LED

Each port has a LINK RX/TX LED. The table below shows the various LED patterns of the ports of the CPU 1515R-2 PN.

Table 5-2 Meaning of LINK RX/TX LED

LINK TX/RX LED	Meaning
 off	There is no Ethernet connection between the PROFINET interface of the PROFINET device and the communication partner. No data is currently being sent/received via the PROFINET interface. There is no LINK connection. The redundancy connections were interrupted. The power supply has failed.
 Flashes green	The CPU performs an LED flash test.
 Illuminated green	There is an Ethernet connection between the PROFINET interface of your PROFINET device and a communication partner.

5.1 Status and error display of the CPU

LINK TX/RX LED	Meaning
 LED flashes yellow/green	Data is currently being received/sent by a communication partner in Ethernet via the PROFINET interface of the PROFINET device. Note that the human eye perceives this LED image as an LED that is lit yellow or flickering yellow.

NOTE

"LED" instruction



You can read the status (e.g. "On" or "Off") of LEDs of a CPU or a module using the "LED" instruction. Note, however, that it is not possible to read the LED status of the LINK RX/TX LEDs on all S7-1500 R/H CPUs.

You can find additional information on the "LED" instruction in the STEP 7 online help.

Meaning of STOP-ACTIVE LED

The following table shows the meaning of the STOP-ACTIVE LED of the CPU 1515-2 PN.

Table 5-3 Meaning of the LED

STOP-ACTIVE LED	Meaning
 LED lit yellow	The CPU has been switched to STOP mode using the STOP button. <ul style="list-style-type: none"> As long as the STOP-ACTIVE LED is lit, switching the CPU to RUN mode is only possible using the RUN button. The CPU can then no longer be put into RUN mode by an operator input on the display or via online functions. The state of the buttons is retained at power-off. If the CPU is not to start up automatically after power-on, you must keep the STOP button pressed during startup until the STOP-ACTIVE LED is activated. If an automatic startup after power-on is to be reliably prevented, the STOP button must be kept pressed during startup of the CPU until the STOP-ACTIVE LED is activated.
 LED off	<ul style="list-style-type: none"> The CPU has been put into STOP mode via the display or programming device/PC and not using the STOP button on the device. The CPU is in RUN mode.

See also

S7-1500R/H Redundant System
<https://support.industry.siemens.com/cs/ww/en/view/109754833>)

Technical specifications

The following table shows the technical specifications as of 01/2024. You can find a data sheet including daily updated technical specifications on the Internet (<https://support.industry.siemens.com/cs/ww/en/pv/6ES7515-2RN03-0AB0/td?dl=en>).

Article number	6ES7515-2RN03-0AB0
General information	
Product type designation	CPU 1515R-2 PN
HW functional status	FS04
Firmware version	V3.1
<ul style="list-style-type: none"> FW update possible 	Yes
Product function	
<ul style="list-style-type: none"> I&M data 	Yes; I&M0 to I&M3
<ul style="list-style-type: none"> Isochronous mode 	No
<ul style="list-style-type: none"> SysLog 	Yes
Engineering with	
<ul style="list-style-type: none"> STEP 7 TIA Portal configurable/integrated from version 	V19 (FW V3.1) / V18 (FW V3.0); with older TIA Portal versions configurable as 6ES7515-2RM00-0AB0
Display	
Screen diagonal [cm]	6.1 cm
Control elements	
Number of keys	8
Mode buttons	2
Supply voltage	
Rated value (DC)	24 V
permissible range, lower limit (DC)	19.2 V
permissible range, upper limit (DC)	28.8 V
Reverse polarity protection	Yes
Mains buffering	
<ul style="list-style-type: none"> Mains/voltage failure stored energy time 	5 ms
<ul style="list-style-type: none"> Repeat rate, min. 	1/s
Input current	
Current consumption (rated value)	0.65 A
Current consumption, max.	0.88 A
Inrush current, max.	1.15 A
I ² t	0.6 A ² ·s
Power loss	
Power loss, typ.	3.6 W

Article number	6ES7515-2RN03-0AB0
Memory	
Number of slots for SIMATIC memory card	1
SIMATIC memory card required	Yes
Work memory	
• integrated (for program)	1 Mbyte
• integrated (for data)	4.5 Mbyte
Load memory	
• Plug-in (SIMATIC Memory Card), max.	32 Gbyte
Backup	
• maintenance-free	Yes
CPU processing times	
for bit operations, typ.	20 ns
for word operations, typ.	24 ns
for fixed point arithmetic, typ.	32 ns
for floating point arithmetic, typ.	128 ns
CPU-blocks	
Number of elements (total)	8 000; Blocks (OB, FB, FC, DB) and UDTs
DB	
• Number range	Number range: 1 to 59 999
• Size, max.	4.5 Mbyte; For non-optimized block accesses, the max. size of the DB is 64 KB
FB	
• Number range	0 ... 65 535
• Size, max.	1 Mbyte
FC	
• Number range	0 ... 65 535
• Size, max.	1 Mbyte
OB	
• Size, max.	1 Mbyte
• Number of free cycle OBs	100
• Number of time alarm OBs	20
• Number of delay alarm OBs	20
• Number of cyclic interrupt OBs	20; with minimum OB 3x cycle of 10 ms
• Number of process alarm OBs	50
• Number of DPV1 alarm OBs	3
• Number of startup OBs	100
• Number of asynchronous error OBs	4
• Number of synchronous error OBs	2
• Number of diagnostic alarm OBs	1

Article number	6ES7515-2RN03-0AB0
Nesting depth	24
<ul style="list-style-type: none"> per priority class 	
Counters, timers and their retentivity	
S7 counter	
<ul style="list-style-type: none"> Number 	2 048
Retentivity	
<ul style="list-style-type: none"> adjustable 	Yes
IEC counter	
<ul style="list-style-type: none"> Number 	Any (only limited by the main memory)
Retentivity	
<ul style="list-style-type: none"> adjustable 	Yes
S7 times	
<ul style="list-style-type: none"> Number 	2 048
Retentivity	
<ul style="list-style-type: none"> adjustable 	Yes
IEC timer	
<ul style="list-style-type: none"> Number 	Any (only limited by the main memory)
Retentivity	
<ul style="list-style-type: none"> adjustable 	Yes
Data areas and their retentivity	
Retentive data area (incl. timers, counters, flags), max.	512 kbyte; Available retentive memory for bit memories, timers, counters, DBs, and technology data (axes): 472 KB
Flag	
<ul style="list-style-type: none"> Size, max. Number of clock memories 	16 kbyte 8; 8 clock memory bit, grouped into one clock memory byte
Data blocks	
<ul style="list-style-type: none"> Retentivity adjustable Retentivity preset 	Yes No
Local data	
<ul style="list-style-type: none"> per priority class, max. 	64 kbyte; max. 16 KB per block
Address area	
Number of IO modules	4 096; max. number of modules / submodules
I/O address area	
<ul style="list-style-type: none"> Inputs Outputs 	32 kbyte; All inputs are in the process image 32 kbyte; All outputs are in the process image
per integrated IO subsystem	
<ul style="list-style-type: none"> Inputs (volume) Outputs (volume) 	8 kbyte 8 kbyte

Article number	6ES7515-2RN03-0AB0
Subprocess images	
<ul style="list-style-type: none"> Number of subprocess images, max. 	31
Hardware configuration	
Number of distributed IO systems	16; A distributed I/O system is characterized not only by the integration of distributed I/O via PROFINET, but also by the connection of I/O via IE/PB-Links.
Number of IO Controllers	
<ul style="list-style-type: none"> integrated 	1
Rack	
<ul style="list-style-type: none"> Modules per rack, max. 	5; CPU + 2 PS + 2 CP
Time of day	
Clock	
<ul style="list-style-type: none"> Type Backup time Deviation per day, max. 	Hardware clock 6 wk; At 40 °C ambient temperature, typically 10 s; Typ.: 2 s
Operating hours counter	
<ul style="list-style-type: none"> Number 	16
Clock synchronization	
<ul style="list-style-type: none"> supported on Ethernet via NTP 	Yes Yes
Interfaces	
Number of PROFINET interfaces	2
1. Interface	
Interface types	
<ul style="list-style-type: none"> RJ 45 (Ethernet) Number of ports integrated switch 	Yes; X1 2 Yes
Protocols	
<ul style="list-style-type: none"> IP protocol PROFINET IO Controller PROFINET IO Device SIMATIC communication Open IE communication Web server Media redundancy 	Yes; IPv4 Yes No Yes; Only Server Yes; Optionally also encrypted Yes Yes

Article number	6ES7515-2RN03-0AB0
PROFINET IO Controller	
Services	
– Isochronous mode	No
– IRT	No
– PROFIenergy	Yes; per user program
– Number of connectable IO Devices, max.	64
– Updating times	The minimum value of the update time also depends on communication share set for PROFINET IO, on the number of IO devices, and on the quantity of configured user data
– PROFINET Security Class	1
Update time for RT	
– for send cycle of 1 ms	1 ms to 512 ms
2. Interface	
Interface types	
• RJ 45 (Ethernet)	Yes; X2
• Number of ports	1
• integrated switch	No
Protocols	
• IP protocol	Yes; IPv4
• PROFINET IO Controller	No
• PROFINET IO Device	No
• SIMATIC communication	Yes; Only Server
• Open IE communication	Yes; Optionally also encrypted
• Web server	Yes
• Media redundancy	No
Interface types	
RJ 45 (Ethernet)	
• 100 Mbps	Yes
• Autonegotiation	Yes
• Autocrossing	Yes
• Industrial Ethernet status LED	Yes
Protocols	
PROFIsafe	No

Article number	6ES7515-2RN03-0AB0
Number of connections <ul style="list-style-type: none"> • Number of connections, max. • Number of connections reserved for ES/HMI/web • Number of connections via integrated interfaces • Number of S7 routing paths 	<p>256; via integrated interfaces of the CPU and connected CPs</p> <p>10</p> <p>128</p> <p>16</p>
Redundancy mode <ul style="list-style-type: none"> • PROFINET system redundancy (S2) • PROFINET system redundancy (R1) 	<p>Yes</p> <p>No</p>
Media redundancy <ul style="list-style-type: none"> – MRP – MRP interconnection, supported – MRPD – Switchover time on line break, typ. – Number of stations in the ring, max. 	<p>Yes; MRP Automanager according to IEC 62439-2 Edition 2.0</p> <p>Yes; as MRP ring node according to IEC 62439-2 Edition 3.0</p> <p>No</p> <p>200 ms; PROFINET MRP</p> <p>50; Only 16 are recommended, however</p>
SIMATIC communication <ul style="list-style-type: none"> • PG/OP communication • S7 routing • S7 communication, as server • S7 communication, as client 	<p>Yes; encryption with TLS V1.3 pre-selected</p> <p>Yes</p> <p>Yes</p> <p>No</p>
Open IE communication <ul style="list-style-type: none"> • TCP/IP <ul style="list-style-type: none"> – Data length, max. – several passive connections per port, supported • ISO-on-TCP (RFC1006) <ul style="list-style-type: none"> – Data length, max. • UDP <ul style="list-style-type: none"> – Data length, max. – UDP multicast • DHCP • DNS • SNMP • DCP • LLDP • Encryption 	<p>Yes</p> <p>64 kbyte</p> <p>Yes</p> <p>Yes</p> <p>64 kbyte</p> <p>Yes</p> <p>2 kbyte; 1 472 bytes for UDP broadcast</p> <p>Yes; max. 118 multicast circuits</p> <p>No</p> <p>Yes</p> <p>Yes</p> <p>Yes</p> <p>Yes</p> <p>Yes</p> <p>Yes; Optional</p>

Article number	6ES7515-2RN03-0AB0
Web server	
<ul style="list-style-type: none"> • HTTP • HTTPS • web API <ul style="list-style-type: none"> – Number of sessions, max. – number of simultaneous HTTP calls, max. – HTTP request body, max. 	<p>No</p> <p>Yes; only via Web API</p> <p>Yes</p> <p>100</p> <p>4</p> <p>131 072 byte</p>
OPC UA	
<ul style="list-style-type: none"> • Runtime license required • OPC UA Client • OPC UA Server <ul style="list-style-type: none"> – Application authentication – Security policies – User authentication – GDS support (certificate management) – Number of sessions, max. – Number of subscriptions per session, max. – Sampling interval, min. – Publishing interval, min. – Number of server methods, max. – Number of inputs/outputs per server method, max. – Number of monitored items, recommended max. – Number of server interfaces, max. – Number of nodes for user-defined server interfaces, max. • Alarms and Conditions 	<p>Yes</p> <p>No</p> <p>Yes; Data access (read, write, subscribe), method call, custom address space</p> <p>Yes</p> <p>available security policies: None, Basic128Rsa15, Basic256Rsa15, Basic256Sha256, Aes128Sha256RsaOaep, Aes256Sha256RsaPss</p> <p>"anonymous" or by user name & password</p> <p>No</p> <p>24</p> <p>25</p> <p>250 ms</p> <p>250 ms</p> <p>50</p> <p>20</p> <p>2 000; for 1 s sampling interval and 1 s send interval</p> <p>10 of each "Server interfaces" / "Companion specification" type and 20 of the type "Reference namespace"</p> <p>30 000</p> <p>No</p>
Further protocols	
<ul style="list-style-type: none"> • MODBUS 	<p>Yes; MODBUS TCP</p>

Article number	6ES7515-2RN03-0AB0
S7 message functions	
Number of login stations for message functions, max.	64
number of subscriptions, max.	500
number of tags/attributes for subscriptions, max.	8 000
Program alarms	Yes
Number of configurable program messages, max.	10 000; Program messages are generated by the "Program_Alarm" block, ProDiag or GRAPH
Number of loadable program messages in RUN, max.	10 000
Number of simultaneously active program alarms	
• Number of program alarms	1 000
• Number of alarms for system diagnostics	200
Test commissioning functions	
Joint commission (Team Engineering)	No
Status block	Yes; up to 8 simultaneously
Single step	No
Number of breakpoints	8; Breakpoints are only supported in RUN-Solo status
Status/control	
• Status/control variable	Yes
• Variables	Inputs/outputs, memory bits, DBs, distributed I/Os, timers, counters
• Number of variables, max.	
– of which status variables, max.	200; per job
– of which control variables, max.	200; per job
Forcing	
• Forcing	Yes
• Forcing, variables	Peripheral inputs/outputs
• Number of variables, max.	200
Diagnostic buffer	
• present	Yes
• Number of entries, max.	3 200
– of which powerfail-proof	500
Traces	
• Number of configurable Traces	4
• Memory size per trace, max.	512 kbyte

Article number	6ES7515-2RN03-0AB0
Interrupts/diagnostics/status information	
Diagnostics indication LED	
<ul style="list-style-type: none"> • RUN/STOP LED 	Yes
<ul style="list-style-type: none"> • ERROR LED 	Yes
<ul style="list-style-type: none"> • MAINT LED 	Yes
<ul style="list-style-type: none"> • STOP ACTIVE LED 	Yes
<ul style="list-style-type: none"> • Connection display LINK TX/RX 	Yes
Supported technology objects	
Motion Control	No
Controller	
<ul style="list-style-type: none"> • PID_Compact 	Yes; Universal PID controller with integrated optimization
<ul style="list-style-type: none"> • PID_3Step 	Yes; PID controller with integrated optimization for valves
<ul style="list-style-type: none"> • PID-Temp 	Yes; PID controller with integrated optimization for temperature
Counting and measuring	Yes
Standards, approvals, certificates	
Suitable for safety functions	No
Ambient conditions	
Ambient temperature during operation	
<ul style="list-style-type: none"> • horizontal installation, min. 	-30 °C; No condensation
<ul style="list-style-type: none"> • horizontal installation, max. 	60 °C; Display: 50 °C, at an operating temperature of typically 50 °C, the display is switched off
<ul style="list-style-type: none"> • vertical installation, min. 	-30 °C; No condensation
<ul style="list-style-type: none"> • vertical installation, max. 	40 °C; Display: 40 °C, at an operating temperature of typically 40 °C, the display is switched off
Ambient temperature during storage/transportation	
<ul style="list-style-type: none"> • min. 	-40 °C
<ul style="list-style-type: none"> • max. 	70 °C
Altitude during operation relating to sea level	
<ul style="list-style-type: none"> • Installation altitude above sea level, max. 	5 000 m; Restrictions for installation altitudes > 2 000 m, see manual
configuration / header	
configuration / programming / header	

Article number	6ES7515-2RN03-0AB0
Programming language	
– LAD	Yes
– FBD	Yes
– STL	Yes
– SCL	Yes
– CFC	No
– GRAPH	Yes
Know-how protection	
• User program protection/password protection	Yes
• Copy protection	No
• Block protection	Yes
Access protection	
• protection of confidential configuration data	Yes
• Password for display	Yes
• Protection level: Write protection	Yes
• Protection level: Read/write protection	Yes
• Protection level: Write protection for Failsafe	No
• Protection level: Complete protection	Yes
• User administration	Yes
programming / cycle time monitoring / header	
• lower limit	adjustable minimum cycle time
• upper limit	adjustable maximum cycle time
Dimensions	
Width	70 mm
Height	147 mm
Depth	129 mm
Weights	
Weight, approx.	456 g

General technical specifications

You can find information on the general technical specifications, such as standards and approvals, electromagnetic compatibility, protection class, etc. in the S7-1500R/H redundant system System Manual.

See also

S7-1500R/H Redundant System

<https://support.industry.siemens.com/cs/ww/en/view/109754833>

A

Dimension drawing

This section contains the dimensional drawing of the module on the mounting rail, as well as a dimensional drawing with the front panel open. Keep to the dimensions when installing in cabinets, control rooms, etc.

Dimension drawings of the CPU 1515R-2 PN

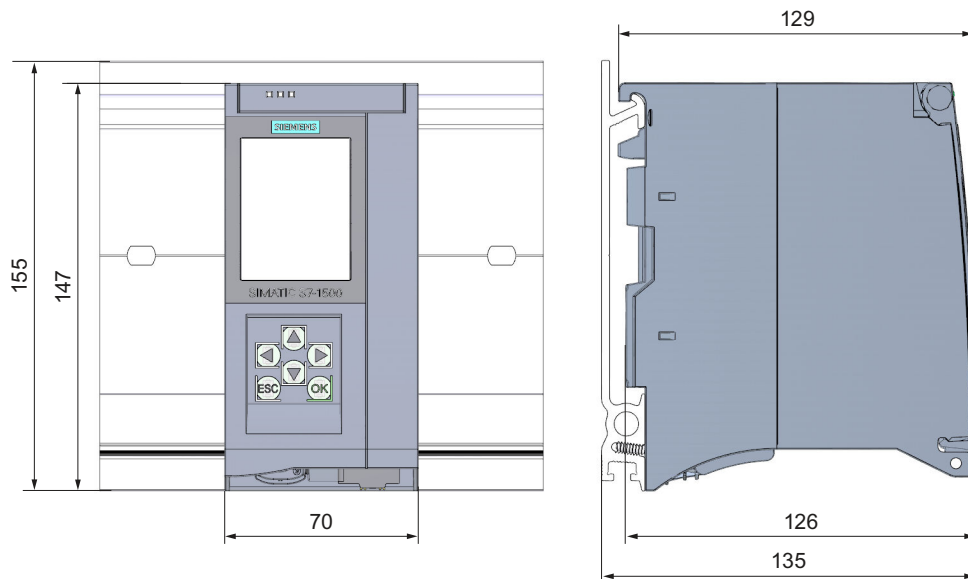

Figure A-1 Dimension drawing of CPU 1515R-2 PN, front and side views

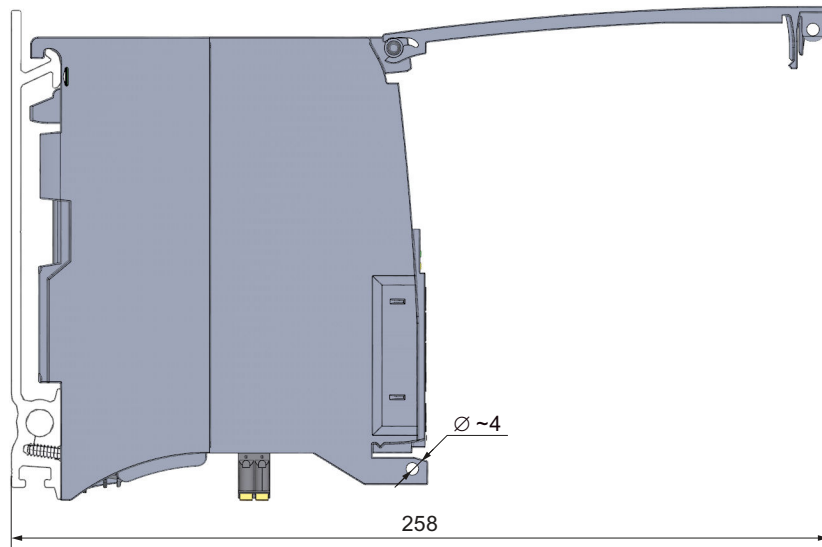

Figure A-2 Dimension drawing CPU 1515R-2 PN, side view with open front panel