



Edition

11/2023

EQUIPMENT MANUAL

# SIMATIC

## S7-1500

CPU 1518-4 PN/DP MFP  
6ES7518-4AX00-1AB0

[support.industry.siemens.com](https://support.industry.siemens.com)

# SIEMENS

SIMATIC

S7-1500

CPU 1518-4 PN/DP MFP  
(6ES7518-4AX00-1AB0)

Equipment Manual

Introduction

1

Industrial cybersecurity

2

Product overview

3

Connecting up

4

Interrupts, error messages,  
diagnostics and system  
alarms

5

Technical specifications

6

Dimensional drawing

A



11/2023

A5E40882737-AD

## Legal information

### Warning notice system

This manual contains notices you have to observe in order to ensure your personal safety, as well as to prevent damage to property. The notices referring to your personal safety are highlighted in the manual by a safety alert symbol, notices referring only to property damage have no safety alert symbol. These notices shown below are graded according to the degree of danger.

 <b>DANGER</b>
indicates that death or severe personal injury <b>will</b> result if proper precautions are not taken.
 <b>WARNING</b>
indicates that death or severe personal injury <b>may</b> result if proper precautions are not taken.
 <b>CAUTION</b>
indicates that minor personal injury can result if proper precautions are not taken.
<b>NOTICE</b>
indicates that property damage can result if proper precautions are not taken.

If more than one degree of danger is present, the warning notice representing the highest degree of danger will be used. A notice warning of injury to persons with a safety alert symbol may also include a warning relating to property damage.

### Qualified Personnel

The product/system described in this documentation may be operated only by **personnel qualified** for the specific task in accordance with the relevant documentation, in particular its warning notices and safety instructions. Qualified personnel are those who, based on their training and experience, are capable of identifying risks and avoiding potential hazards when working with these products/systems.

### Proper use of Siemens products

Note the following:

 <b>WARNING</b>
Siemens products may only be used for the applications described in the catalog and in the relevant technical documentation. If products and components from other manufacturers are used, these must be recommended or approved by Siemens. Proper transport, storage, installation, assembly, commissioning, operation and maintenance are required to ensure that the products operate safely and without any problems. The permissible ambient conditions must be complied with. The information in the relevant documentation must be observed.

### Trademarks

All names identified by ® are registered trademarks of Siemens AG. The remaining trademarks in this publication may be trademarks whose use by third parties for their own purposes could violate the rights of the owner.

### Disclaimer of Liability

We have reviewed the contents of this publication to ensure consistency with the hardware and software described. Since variance cannot be precluded entirely, we cannot guarantee full consistency. However, the information in this publication is reviewed regularly and any necessary corrections are included in subsequent editions.

# Table of contents

<b>1</b>	<b>Introduction.....</b>	<b>5</b>
1.1	Guide documentation S7-1500/ET 200MP.....	6
1.1.1	Information classes S7-1500/ET 200MP.....	6
1.1.2	SIMATIC Technical Documentation.....	8
<b>2</b>	<b>Industrial cybersecurity.....</b>	<b>10</b>
2.1	Introduction to industrial cybersecurity.....	10
2.2	Cybersecurity information.....	10
2.3	Cybersecurity-relevant information.....	11
<b>3</b>	<b>Product overview.....</b>	<b>13</b>
3.1	New functions.....	13
3.2	Applications of the S7-1500 CPUs.....	15
3.3	Hardware properties.....	24
3.4	Firmware functions.....	26
3.4.1	Quick start instructions for commissioning C/C++ Runtime.....	30
3.4.2	Supplied libraries for C/C++ Runtime .....	35
3.5	Operating and display elements.....	36
3.5.1	Front view of the CPU with the front panel.....	36
3.5.2	Front view of the CPU without front panel.....	38
3.5.3	Rear view of the CPU.....	39
3.6	Mode selector switch.....	39
<b>4</b>	<b>Connecting up.....</b>	<b>40</b>
<b>5</b>	<b>Interrupts, error messages, diagnostics and system alarms.....</b>	<b>45</b>
5.1	Status and error display of the CPU.....	45
<b>6</b>	<b>Technical specifications.....</b>	<b>48</b>
<b>A</b>	<b>Dimensional drawing.....</b>	<b>64</b>

# Introduction

## Purpose of the documentation

This manual supplements the system manual of the S7-1500 automation system / ET 200MP distributed I/O system as well as the function manuals. This manual contains a description of the module-specific information. The system-related functions are described in the system manual. All system-spanning functions are described in the function manuals.

The information provided in this manual and the system manual enables you to commission the CPU 1518-4 PN/DP MFP.

## Basic knowledge required

To understand this documentation, you need to have general knowledge of automation engineering. You also need basic knowledge of the following topics:

- Knowledge of the industrial automation system SIMATIC
- Knowledge of working with STEP 7
- Knowledge of working with Linux systems
- Knowledge of programming with C/C++
- Working with the Eclipse development environment

## Conventions

- **STEP 7:** In this documentation, "STEP 7" is used as a synonym for all versions of the configuration and programming software "STEP 7 (TIA Portal)".
- **ODK:** Open Development Kit
- **SO:** Shared Object
- **MFP:** Multifunctional platform

Please also observe notes marked as follows:

---

### NOTE

A note contains important information on the product described in the documentation, on the handling of the product or on the section of the documentation to which particular attention should be paid.

---

## Recycling and disposal

For environmentally friendly recycling and disposal of your old equipment, contact a certified electronic waste disposal company and dispose of the equipment according to the applicable regulations in your country.

## Industry Mall

The Industry Mall is the catalog and order system of Siemens AG for automation and drive solutions on the basis of Totally Integrated Automation (TIA) and Totally Integrated Power (TIP).

You can find catalogs for all automation and drive products on the Internet (<https://mall.industry.siemens.com>).

## ID link for the digital nameplate



The ID link is a globally unique identifier according to IEC 61406-1, which you will find in the future as a QR code on your product.

The figure shows an example of an ID link for the CPU 1518-4 PN/DP MFP.

You can recognize the ID link by the frame with a black corner at the bottom right. The ID link takes you to the digital nameplate of your product.

Scan the QR code on the product or on the packaging label with a smartphone camera, barcode scanner, or reader app. Call the ID link.

In the digital nameplate, you will find product data, manuals, declarations of conformity, certificates, and other helpful information about your product.

## 1.1 Guide documentation S7-1500/ET 200MP

### 1.1.1 Information classes S7-1500/ET 200MP



The documentation for the SIMATIC S7-1500 automation system and the ET 200MP distributed I/O system is arranged into three areas.

This arrangement enables you to access the specific content you require. Changes and supplements to the manuals are documented in a Product Information.

You can download the documentation free of charge from the Internet (<https://support.industry.siemens.com/cs/ww/en/view/109742691>).

### Basic information



The System Manual and Getting Started describe in detail the configuration, installation, wiring and commissioning of the SIMATIC S7-1500 and ET 200MP systems.

The STEP 7 online help supports you in the configuration and programming.

Examples:

- Getting Started S7-1500
- S7-1500/ET 200MP System Manual
- Online help TIA Portal

## Device information



Equipment manuals contain a compact description of the module-specific information, such as properties, wiring diagrams, characteristics and technical specifications.

Examples:

- Equipment Manuals CPUs
- Equipment Manuals Interface Modules
- Equipment Manuals Digital Modules
- Equipment Manuals Analog Modules
- Equipment Manuals Communications Modules
- Equipment Manuals Technology Modules
- Equipment Manuals Power Supply Modules

## General information



The function manuals contain detailed descriptions on general topics relating to the SIMATIC S7-1500 and ET 200MP systems.

Examples:

- Function Manual Diagnostics
- Function Manual Communication
- Function Manual Motion Control
- Function Manual Web Server
- Function Manual Cycle and Response Times
- PROFINET Function Manual
- PROFIBUS Function Manual

## Product Information

Changes and supplements to the manuals are documented in a Product Information. The Product Information takes precedence over the device and system manuals.

You can find the latest Product Information on the S7-1500 and ET 200MP systems on the Internet (<https://support.industry.siemens.com/cs/de/en/view/68052815>).

## Manual Collection S7-1500/ET 200MP

The Manual Collection contains the complete documentation on the SIMATIC S7-1500 automation system and the ET 200MP distributed I/O system gathered together in one file. You can find the Manual Collection on the Internet.

(<https://support.industry.siemens.com/cs/ww/en/view/86140384>)

## Manual Collection fail-safe modules

The Manual Collection contains the complete documentation on the fail-safe SIMATIC modules, gathered together in one file.

You can find the Manual Collection on the Internet.

(<https://support.industry.siemens.com/cs/de/en/view/109806400>)

## SIMATIC S7-1500 comparison list for programming languages

The comparison list contains an overview of which instructions and functions you can use for which controller families.

You can find the comparison list on the Internet

(<https://support.industry.siemens.com/cs/ww/en/view/86630375>).

### 1.1.2 SIMATIC Technical Documentation

Additional SIMATIC documents will complete your information. You can find these documents and their use at the following links and QR codes.

The Industry Online Support gives you the option to get information on all topics. Application examples support you in solving your automation tasks.

#### Overview of the SIMATIC Technical Documentation

Here you will find an overview of the SIMATIC documentation available in Siemens Industry Online Support:



Industry Online Support International

(<https://support.industry.siemens.com/cs/ww/en/view/109742705>)

Watch this short video to find out where you can find the overview directly in Siemens Industry Online Support and how to use Siemens Industry Online Support on your mobile device:



Quick introduction to the technical documentation of automation products per video (<https://support.industry.siemens.com/cs/us/en/view/109780491>)



YouTube video: Siemens Automation Products - Technical Documentation at a Glance (<https://youtu.be/TwLSxxRQsA>)

#### Retention of the documentation

Retain the documentation for later use.

For documentation provided in digital form:

1. Download the associated documentation after receiving your product and before initial installation/commissioning. Use the following download options:

- Industry Online Support International: (<https://support.industry.siemens.com>)

The article number is used to assign the documentation to the product. The article number is specified on the product and on the packaging label. Products with new, non-compatible functions are provided with a new article number and documentation.

- ID link:

Your product may have an ID link. The ID link is a QR code with a frame and a black frame corner at the bottom right. The ID link takes you to the digital nameplate of your product. Scan the QR code on the product or on the packaging label with a smartphone camera, barcode scanner, or reader app. Call up the ID link.



2. Retain this version of the documentation.

## Updating the documentation

The documentation of the product is updated in digital form. In particular in the case of function extensions, the new performance features are provided in an updated version.

1. Download the current version as described above via the Industry Online Support or the ID link.
2. Also retain this version of the documentation.

## mySupport

With "mySupport" you can get the most out of your Industry Online Support.

<b>Registration</b>	You must register once to use the full functionality of "mySupport". After registration, you can create filters, favorites and tabs in your personal workspace.
<b>Support requests</b>	Your data is already filled out in support requests, and you can get an overview of your current requests at any time.
<b>Documentation</b>	In the Documentation area you can build your personal library.
<b>Favorites</b>	You can use the "Add to mySupport favorites" to flag especially interesting or frequently needed content. Under "Favorites", you will find a list of your flagged entries.
<b>Recently viewed articles</b>	The most recently viewed pages in mySupport are available under "Recently viewed articles".
<b>CAX data</b>	The CAX data area gives you access to the latest product data for your CAX or CAE system. You configure your own download package with a few clicks: <ul style="list-style-type: none"> <li>• Product images, 2D dimension drawings, 3D models, internal circuit diagrams, EPLAN macro files</li> <li>• Manuals, characteristics, operating manuals, certificates</li> <li>• Product master data</li> </ul>

You can find "mySupport" on the Internet. (<https://support.industry.siemens.com/My/ww/en>)

## Application examples

The application examples support you with various tools and examples for solving your automation tasks. Solutions are shown in interplay with multiple components in the system - separated from the focus on individual products.

You can find the application examples on the Internet.  
(<https://support.industry.siemens.com/cs/ww/en/ps/ae>)

# Industrial cybersecurity

## 2.1 Introduction to industrial cybersecurity

Due to the digitalization and increasing networking of machines and industrial plants, the risk of cyber attacks is also growing. Appropriate protective measures are therefore mandatory, particularly in the case of critical infrastructure facilities.

Refer to the System Manual (<https://support.industry.siemens.com/cs/us/en/view/59191792>) for general information and measures regarding industrial cybersecurity.

This section provides an overview of security-related information pertaining to your SIMATIC device.

---

### NOTE

Security-relevant changes to software or devices are documented in the section "New functions ([Page 13](#))".

---

## 2.2 Cybersecurity information

Siemens provides products and solutions with industrial cybersecurity functions that support the secure operation of plants, systems, machines, and networks.

In order to protect plants, systems, machines, and networks against cyber threats, it is necessary to implement – and continuously maintain – a holistic, state-of-the-art industrial cybersecurity concept. Siemens' products and solutions constitute one element of such a concept.

Customers are responsible for preventing unauthorized access to their plants, systems, machines and networks. Such systems, machines and components should only be connected to an enterprise network or the internet if and to the extent such a connection is necessary and only when appropriate security measures (e.g. firewalls and/or network segmentation) are in place.

For more information on protective industrial cybersecurity measures for implementation, please visit (<https://www.siemens.com/global/en/products/automation/topic-areas/industrial-cybersecurity.html>).

Siemens' products and solutions undergo continuous development to make them more secure. Siemens strongly recommends that product updates are applied as soon as they are available and that the latest product versions are used. Use of product versions that are no longer supported, and failure to apply the latest updates may increase customers' exposure to cyber threats.

To stay informed about product updates at all times, subscribe to the Siemens Industrial Cybersecurity RSS Feed under (<https://new.siemens.com/global/en/products/services/cert.html>).

## 2.3 Cybersecurity-relevant information

Note all cybersecurity-relevant information.

Topics with cybersecurity-relevant information	Reference
<b>Operational application environment and security assumptions</b>	
Requirements for the operational application environment of the system and security assumptions	This section is found in the System Manual ( <a href="https://support.industry.siemens.com/cs/us/en/view/59191792">https://support.industry.siemens.com/cs/us/en/view/59191792</a> ).
Area of application	You can find the section Area of application (Page 15) in this Equipment Manual.
<b>Security properties of the product</b>	
<p>Access protection</p> <p>Physical protection:</p> <ul style="list-style-type: none"> <li>You can protect the CPU against unauthorized access by locking the front flap.</li> </ul> <p>Password protection</p> <p>You can also protect the CPU with a password.</p> <p>Password categories:</p> <ul style="list-style-type: none"> <li>Password to protect confidential configuration data</li> <li>Password in the context of user management (UMAC)</li> <li>Password for display</li> </ul>	<p>Information on locking and on password protection can be found in this Equipment Manual in the section Operator controls and display elements (Page 36).</p> <p>Also note the information on the topic of access protection in the Protection section of the System Manual (<a href="https://support.industry.siemens.com/cs/us/en/view/59191792">https://support.industry.siemens.com/cs/us/en/view/59191792</a>).</p>
<p>Integrated protection functions</p> <ul style="list-style-type: none"> <li>The CPUs have integrated protection functions.</li> </ul>	<p>For information on the protection functions, refer to the "Overview of protection functions" section of the System Manual (<a href="https://support.industry.siemens.com/cs/us/en/view/59191792">https://support.industry.siemens.com/cs/us/en/view/59191792</a>).</p>
<p>PROFINET Security Class 1</p> <ul style="list-style-type: none"> <li>The device supports PROFINET Security Class 1.</li> <li>With the introduction of PROFINET Security Class 1, additional security settings have been integrated into the PROFINET communication.</li> </ul>	<p>Detailed information about PROFINET Security Class 1 and the additional security settings can be found in the PROFINET with STEP 7 Function Manual (<a href="https://support.industry.siemens.com/cs/us/en/view/49948856">https://support.industry.siemens.com/cs/us/en/view/49948856</a>).</p>
Reading out and verifying signatures	You can find detailed information on reading and verifying signatures in the STEP 7 online help (TIA Portal).
Supported Ethernet services	<p>Information about supported services can be found in the section Technical specifications (Page 48).</p> <p>You can find detailed information on the supported Ethernet services in the Communication Function Manual (<a href="https://support.industry.siemens.com/cs/us/en/view/59192925">https://support.industry.siemens.com/cs/us/en/view/59192925</a>).</p>
<b>Interfaces, ports, protocols and services</b>	
<p>Information on the following is security related:</p> <ul style="list-style-type: none"> <li>Communications layer and communication role</li> <li>Default states</li> <li>Enabling/disabling ports and services</li> </ul>	<p>You can find detailed information on these topics in the Communication Function Manual (<a href="https://support.industry.siemens.com/cs/us/en/view/59192925">https://support.industry.siemens.com/cs/us/en/view/59192925</a>).</p>
<b>Secure operation</b>	

2.3 Cybersecurity-relevant information

Topics with cybersecurity-relevant information	Reference
Corrective measures for known risks	Corrective measures for known risks are announced on the Siemens ProductCERT ( <a href="https://siemens.com/productcert">https://siemens.com/productcert</a> ) Web page. For more information on SIEMENS ProductCERT, refer to the System Manual ( <a href="https://support.industry.siemens.com/cs/us/en/view/59191792">https://support.industry.siemens.com/cs/us/en/view/59191792</a> ).
Security checks	Application-specific security measures such as cyclic checks of the configuration via checksums are described in the System Manual ( <a href="https://support.industry.siemens.com/cs/us/en/view/59191792">https://support.industry.siemens.com/cs/us/en/view/59191792</a> ).
Recording Security events	Information on recording security events can be found in the "Safe operation of CPUs" section of the System Manual ( <a href="https://support.industry.siemens.com/cs/us/en/view/59191792">https://support.industry.siemens.com/cs/us/en/view/59191792</a> ).
Secure decommissioning Products that contain security-relevant data must be securely decommissioned before disposal or resale.	Information on secure decommissioning can be found in the "Safe operation of the system" section of the System Manual ( <a href="https://support.industry.siemens.com/cs/us/en/view/59191792">https://support.industry.siemens.com/cs/us/en/view/59191792</a> ).

## Product overview

### 3.1 New functions

This section contains an overview of the most important new firmware functions of the CPU compared with the predecessor version CPU (V3.0).

#### New functions of the CPU in firmware version V3.1

New functions	Applications	Customer benefits
<b>Integrated safety</b>		
Syslog messages	The CPU stores syslog messages in a local cache (temporary memory). The messages can be forwarded to a syslog server.	The syslog server saves all syslog messages from its connected devices. The messages can be displayed on the interface of the server and potential security risks can be identified.
Local user management	As of TIA Portal version V19 and FW version V3.1, the CPUs feature improved management of users, roles, and CPU function rights (User Management & Access Control, UMAC). Starting with the above mentioned version, you can manage all project users with their rights (e.g. access rights) for all CPUs in the project. You can do this in the editor for users and roles in the TIA Portal.	Project users can be managed via the TIA Portal with their rights (for example, access rights) for all CPUs in the project in the editor for users and roles.
<b>Communication of the CPU</b>		
Implementation of PROFINET Security Class 1	As of V19, STEP 7 offers extended configuration options for the SNMP and DCP protocols in order to meet the requirements for PROFINET Security Class 1.	Additional protection of communication within your PROFINET network.
Project-internal shared device/shared I-device	As of STEP7 V19, a shared device/shared I-device together with a maximum of two IO controllers can be created in a single project. Previously, the second IO controller required its own project.	Simpler configuration.
Handling timeouts while exchanging data	When network loads are high, timeouts may occur in PROFINET IO devices during data record communication. Previously, the PROFINET IO communication was reduced by the CPU in this case. As of STEP 7 V19 and FW version V3.1, you can configure the behavior of the respective PROFINET interface.	PROFINET IO communication is maintained even under high grid loads
<b>Web server of the CPU</b>		
New Web API methods:	Many new API methods extend your access options to the CPU via the Web API.	Additional applications for the web server
<b>Technology functions of the CPU</b>		

3.1 New functions

New functions	Applications	Customer benefits
Axis functions	Measuring gearbox for positioning/synchronous axis	Advanced configuration options
	Torque feedforward control for positioning/synchronous axis: The torque feedforward control of the CPU controls the torque required to accelerate the axis, taking into account the motion profile.	Complex motion sequences can be executed faster and more precisely. This leads to a reduction of following errors in acceleration phases.
	Three drive stop modes can be configured for the alarm response "Remove enable".	You can choose between a deceleration ramp, coasting down, and rapid stop.
	Dynamic filter with floating mean value	The new "Floating mean value filter" mode is available for the dynamic filter.
	Standstill signal on external encoder	The standstill signal is also available for external encoders. The standstill signal is output when the encoder values are within the defined standstill window.
	Virtual axis	The axis is operated in the virtual mode with improved runtime behavior. The new mode replaces the existing behavior of the virtual axis.
Measuring input functions	Monitoring measuring input	With the "Measuring via monitoring" measuring input type, the measuring input can capture the measured signal of another configured measuring input.
	Cyclic measuring for central measuring input	Cyclic measuring possible without additional technology module
<b>Trace functionality of the CPU</b>		
Live monitoring for the long-term trace	With live monitoring for the long-term trace, you can: <ul style="list-style-type: none"> <li>• Display and analyze values directly in the graph during recording</li> <li>• Use superimposed measurements for the long-term trace</li> <li>• Synchronize time bases</li> </ul>	Improved display and analysis of long-term traces
Long-term project trace	With the long-term project trace, you can record signals of different S7-1500 CPUs simultaneously. The CPUs must be configured in a network. The recording is stored on a drive that you have configured.	Extended scope of functions

Reference

You can find an overview of all new functions, improvements and revisions in the respective firmware versions on the Internet (<https://support.industry.siemens.com/cs/ww/en/view/109478459>).

## 3.2 Applications of the S7-1500 CPUs

### Application

SIMATIC S7-1500 is the modular control system for a wide variety of automation applications in discrete automation.

SIMATIC S7-1500 is the cost-effective and convenient solution for a broad range of tasks and offers the following advantages:

- Modular, fanless design
- Simple realization of distributed structures
- User-friendly handling

Areas of application of the SIMATIC S7-1500 automation system include, for example:

- Special-purpose machines
- Textile machinery
- Packaging machines
- General mechanical engineering
- Controller engineering
- Machine tool engineering
- Installation engineering
- Electrical industry and crafts
- Automobile engineering
- Water/waste water
- Food & Beverage

Areas of application of the SIMATIC S7-1500R/H redundant system include, for example:

- Tunnels
- Airports (e.g. baggage conveyors)
- Subways
- Shipbuilding
- Wastewater treatment plants
- High-bay warehouses

Areas of application of the SIMATIC S7-1500T automation system for advanced motion control applications include, for example:

- Packaging machines
- Converting applications
- Assembly automation
- Pick-and-place automation
- Palletizers

You can choose between CPUs with various levels of performance and a comprehensive range of modules with many convenient functions. Fail-safe CPUs enable use in fail-safe applications. The modular design allows you to use only the modules that you need for your application. The controller can be retrofitted with additional modules at any time to expand its range of tasks.

High industrial suitability due to the high resistance to EMC, shock and vibration enable universal use of the SIMATIC S7-1500, S7-1500R/H and S7-1500T automation systems.

### Performance segments of standard CPUs

The CPUs can be used for smaller and mid-range applications, as well as for the high-end range of machine and plant automation.

Table 3-1 Standard CPUs

CPU	Performance segment	PROFIBUS interfaces	PROFINET IO RT/IRT interfaces	PROFINET IO RT interface	Basic PROFINET functionality	Work memory	Processing time for bit operations
CPU 1511-1 PN	Standard CPU for small to mid-range applications	--	1	--	--	1.8 MB	25 ns
CPU 1513-1 PN	Standard CPU for mid-range applications	--	1	--	--	3.1 MB	25 ns
CPU 1515-2 PN	Standard CPU for mid-range to large applications	--	1	1	--	5.5 MB	6 ns
CPU 1516-3 PN/DP	Standard CPU for high-end applications and communication tasks	1	1	1	--	9.5 MB	6 ns
CPU 1517-3 PN/DP	Standard CPU for high-end applications and communication tasks	1	1	1	--	10 MB	2 ns
CPU 1518-4 PN/DP	Standard CPU for high-performance applications, demanding communication tasks and very short reaction times	1	1	1	1	66 MB	1 ns
CPU 1518-4 PN/DP MFP	Standard CPU for high-performance applications, demanding communication tasks, very short reaction times and C/C++ blocks for the user program	1	1	1	1	116* MB	1 ns

\* 50 MB of the integrated work memory is reserved for the function library of CPU runtime



## Performance segments of redundant CPUs

The CPUs of the S7-1500R/H redundant system offer a high degree of reliability and system availability. A redundant configuration of the most important automation components reduces the likelihood of production downtimes and the consequences of component errors. The higher the risks and costs of a production downtime, the more worthwhile the use of a redundant system. The avoidance of production downtimes compensates for the generally higher investment costs.

Table 3-2 Redundant CPUs

CPU	Performance segment	PROFIBUS interfaces	PROFINET IO RT/IRT interfaces	PROFINET IO RT interface	Basic PROFINET functionality	Work memory	Processing time for bit operations
CPU 1513R-1 PN	Redundant CPU for smaller to mid-range applications	--	1	--	--	3.1 MB	50 ns
CPU 1515R-2 PN	Redundant CPU for mid-range to large applications	--	1	--	1	5.5 MB	20 ns
CPU 1517H-3 PN	Redundant CPU for demanding applications and communication tasks	--	1	--	1	10 MB	4 ns
CPU 1518HF-4 PN	Fail-safe and redundant CPU for demanding applications and communication tasks	--	1	--	2	69 MB	4 ns

## Performance segments of compact CPUs

The compact CPUs can be used for smaller to mid-range applications and have an integrated analog and digital on-board I/O as well as integrated technology functions.

Table 3-3 Compact CPUs

CPU	Performance segment	PROFIBUS interfaces	PROFINET IO RT/IRT interfaces	PROFINET IO RT interface	Basic PROFINET functionality	Work memory	Processing time for bit operations
CPU 1511C-1 PN	Compact CPU for small to mid-range applications	--	1	--	--	1.175 MB	60 ns
CPU 1512C-1 PN	Compact CPU for mid-range applications	--	1	--	--	1.25 MB	48 ns

The following table shows the specific properties of the Compact CPUs.

	CPU 1511C-1 PN	CPU 1512C-1 PN
Integrated analog inputs/outputs	5 inputs/2 outputs	5 inputs/2 outputs
Integrated digital inputs/outputs	16 inputs/16 outputs	32 inputs/32 outputs
High-speed counters	6	6
Frequency meters	6 (max. 100 kHz)	6 (max. 100 kHz)

3.2 Applications of the S7-1500 CPUs

	CPU 1511C-1 PN	CPU 1512C-1 PN
Period duration measurement	6 channels	6 channels
Pulse width modulation (PWM output)	Max. 4 (up to 100 kHz)	Max. 4 (up to 100 kHz)
Pulse Train Output (PTO output)	Max. 4 (up to 100 kHz)	Max. 4 (up to 100 kHz)
Frequency output	Up to 100 kHz	Up to 100 kHz

**Performance segments of technology CPUs**

The technology CPUs can be used for low and mid-range applications, as well as for the high-end range of machine and plant automation. Because of their extended motion control functions, they are primarily used for drive control.

Table 3-4 Technology CPUs

CPU	Performance segment	PROFIBUS interfaces	PROFINET IO RT/IRT interfaces	PROFINET IO RT interface	Basic PROFINET functionality	Work memory	Processing time for bit operations
CPU 1511T-1 PN	Technology CPU for small to mid-range applications	--	1	--	--	1.95 MB	25 ns
CPU 1515T-2 PN	Technology CPU for mid-range to large applications	--	1	1	--	6 MB	6 ns
CPU 1516T-3 PN/DP	Technology CPU for high-end applications and communication tasks	1	1	1	--	10.5 MB	6 ns
CPU 1517T-3 PN/DP	Technology CPU for high-end applications and communication tasks	1	1	1	--	11 MB	2 ns
CPU 1518T-4 PN/DP	Technology CPU for high-performance motion control applications with large quantities, demanding communication tasks and very short reaction times	1	1	1	1	69 MB	1 ns
CPU 1511TF-1 PN CPU 1515TF-2 PN CPU 1516TF-3 P-N/DP CPU 1517TF-3 PN/DP CPU 1518TF-4 PN/DP	These CPUs are described in the fail-safe CPUs.						

## Performance segments of fail-safe CPUs

The fail-safe CPUs are intended for users who want to implement demanding standard and fail-safe applications both centrally and decentrally.

These fail-safe CPUs allow the processing of standard and safety programs on a single CPU. This allows fail-safe data to be evaluated in the standard user program. The integration also provides the system advantages and the extensive functionality of SIMATIC for fail-safe applications.

The fail-safe CPUs are certified for use in safety mode up to:

- Safety class (Safety Integrity Level) SIL 3 according to IEC 61508:2010
- Performance Level (PL) e and Category 4 according to ISO 13849-1:2015 or EN ISO 13849-1:2015

Additional password protection for F-configuration and F-program is set up for IT security.

Table 3-5 Fail-safe CPUs

CPU	Performance segment	PROFIBUS interfaces	PROFINET IO RT/IRT interfaces	PROFINET IO RT interface	Basic PROFINET functionality	Work memory	Processing time for bit operations
CPU 1511F-1 PN	Fail-safe CPU for smaller to medium-sized applications	--	1	--	--	1.95 MB	25 ns
CPU 1511TF-1 PN	Fail-safe technology CPU for small to mid-range applications	--	1	--	--	1.95 MB	25 ns
CPU 1513F-1 PN	Fail-safe CPU for medium-sized applications	--	1	--	--	3.4 MB	25 ns
CPU 1515F-2 PN	Fail-safe CPU for medium-sized to large applications	--	1	1	--	6 MB	6 ns
CPU 1515TF-2 PN	Fail-safe technology CPU for high-end applications and communication tasks	--	1	1	--	6 MB	6 ns
CPU 1516F-3 PN/DP	Fail-safe CPU for demanding applications and communications tasks	1	1	1	--	10.5 MB	6 ns
CPU 1516TF-3 P-N/DP	Fail-safe technology CPU for high-end applications and communication tasks	1	1	1	--	10.5 MB	6 ns
CPU 1517F-3 PN/DP	Fail-safe CPU for demanding applications and communications tasks	1	1	1	--	11 MB	2 ns
CPU 1517TF-3 PN/DP	Fail-safe technology CPU for high-end applications and communication tasks	1	1	1	--	11 MB	2 ns

\* 50 MB of the integrated work memory is reserved for the function library of CPU runtime

3.2 Applications of the S7-1500 CPUs

CPU	Performance segment	PROFIBUS interfaces	PROFINET IO RT/IRT interfaces	PROFINET IO RT interface	Basic PROFINET functionality	Work memory	Processing time for bit operations
CPU 1518F-4 PN/DP	Fail-safe CPU for high-performance applications, demanding communication tasks and very short reaction times	1	1	1	1	69 MB	1 ns
CPU 1518F-4 PN/DP MFP	Fail-safe CPU for high-performance applications, demanding communication tasks, very short reaction times and C/C++ blocks for the user program	1	1	1	1	119* MB	1 ns
CPU 1518TF-4 PN/DP	Technology CPU for high-performance motion control applications with large quantities, demanding communication tasks and very short reaction times	1	1	1	1	69 MB	1 ns

\* 50 MB of the integrated work memory is reserved for the function library of CPU runtime

In addition to the CPUs, further components such as SINAMICS drives dispose of integrated safety functions. Additional information about integrated safety functions in drives can be found in the manuals for the respective products.

**Power segment of the CPU 1518-4 PN/DP MFP**

The CPU 1518-4 PN/DP MFP can be used for the high-end area of machine and plant automation.

The CPU 1518-4 PN/DP MFP offers you the following options:

- Executing STEP 7 blocks of the "standard" user program
- Executing applications that were programmed in C/C++ with the Open Development Kit ODK
  - Run C/C++ code synchronously in the CPU cycle via the CPU function library
  - Run C/C++ applications as separate applications parallel to CPU runtime

The CPU 1518-4 PN/DP MFP is suitable for:

- Complex protocol connections according to IEC 61850 and SECS/GEM
- Database connections, for example, SQL databases
- Data preprocessing for preparing complex data, for example, for management decisions
- Executing complex algorithms, for example, for optimizing processes

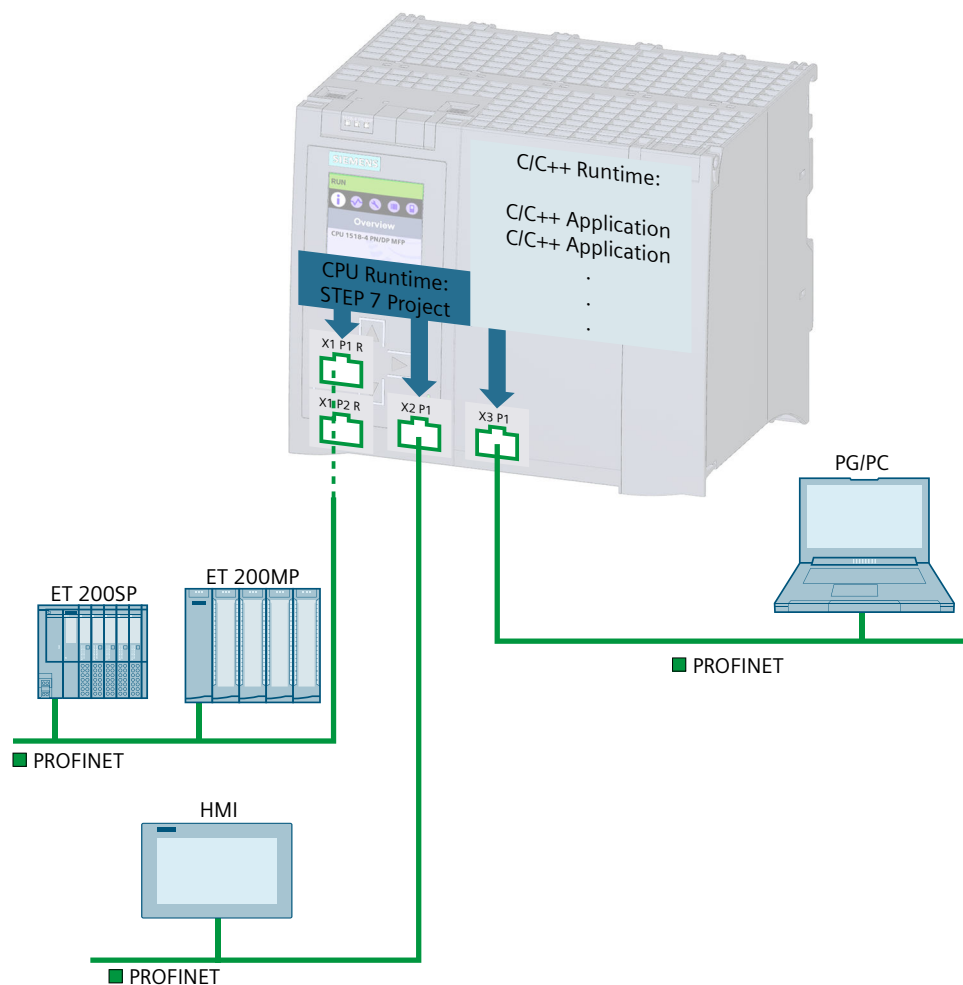

Figure 3-1 Overview of the performance segment

You create the *C/C++* blocks (CPU function library for CPU Runtime) and *C/C++*-Runtime applications with the "Open Development Kit ODK 1500S" (ODK).

Employing the ODK enables you to use mechanisms from high-level programming languages (e.g. object-based) within a modern programming environment.

#### NOTE

To be able to use SIMATIC Industrial OS from firmware version V2.8.4 onwards, use the Open Development Kit 1500S Version V2.5 SP2 or higher. More information about the Open Development Kit 1500S Version V2.5 SP2 can be found on the Internet

(<https://support.industry.siemens.com/cs/ww/en/view/109782540>).

With ODK, you program:

- Blocks in *C/C++* that can be run synchronously in the execution cycle of the CPU (CPU function library for CPU Runtime)
- *C/C++* Runtime applications running in SIMATIC S7-1500 MFP *C/C++* Runtime, independent of the STEP 7 user program

You can use *C/C++* Runtime applications to implement parallel processes to the STEP 7 user program, for example, for pre-processing or transmitting data via Industrial Ethernet. A CPU

can simultaneously perform more tasks, the complexity of functions is reduced and the time required for implementation decreased.

You can reuse existing C/C++ algorithms. To continue using existing technological know-how, you can integrate the existing C/C++ code via the Open Development Kit:

- In the runtime environment of the CPU or
- As C/C++ Runtime applications into the SIMATIC S7-1500 MFP C/C++ Runtime

Once you integrate the C/C++ sources, you can execute them on the CPU.

You can find a description of the Open Development Kit in the SIMATIC S7-1500 ODK 1500S (<https://support.industry.siemens.com/cs/ww/en/ps/13914/man>) Programming and Operating Manual, V2.5 and higher, edition 12/2017. The sections that describe the CPU function library for CPU Runtime and the C/C++ Runtime applications apply to the CPU 1518-4 PN/PN/DP MFP.

The work memory and the load memory of the CPU 1518-4 PN/DP MFP are divided as follows:

Work memory for:

- The STEP 7 user program
- for CPU function library for CPU Runtime
- for C/C++ Runtime applications

Load memory for:

- the STEP 7 user program including CPU function library for CPU Runtime
- for C/C++ Runtime applications

## Security Integrated

In conjunction with STEP 7, each CPU offers password-based know-how protection against unauthorized reading out or modification of the program blocks.

Copy protection provides reliable protection against unauthorized reproduction of program blocks. With copy protection, individual blocks on the SIMATIC Memory Card can be tied to its serial number so that the block can only be run if the configured memory card is inserted into the CPU.

In addition, all project users can be managed with the local user management. Rights, such as access rights, can be set individually for each user.

Improved manipulation protection allows changed or unauthorized transfers of engineering data to be detected by the controller.

The use of an Ethernet CP (CP 1543-1) provides you with additional access protection through a firewall or possibilities to establish secure VPN connections.

## Design and handling

All CPUs of the SIMATIC S7-1500 product series feature a display with plain text information. The display provides the user with information on the order numbers, firmware version, and serial number of all connected modules. In addition, the IP address of the CPU and other network settings can be adapted locally without a programming device. Errors messages are immediately shown on the display in plain text. When performing servicing, you can minimize plant downtimes by quickly accessing the diagnostics messages. Detailed information about this and a multitude of other display functions is available in the SIMATIC S7-1500 Display Simulator

(<https://support.industry.siemens.com/cs/ww/de/view/109761758/en>).

Uniform front connectors for all modules and integrated potential jumpers for flexible formation of potential groups simplify storage. Additional components such as circuit

breakers, relays, etc., can be installed quickly and easily because a DIN rail is implemented in the rail of the SIMATIC S7-1500. The CPUs of the SIMATIC S7-1500 product series can be expanded centrally and in a modular fashion with signal modules. Space-saving expansion enables flexible adaptation to each application.

The system cabling for digital signal modules enables fast and clear connection to sensors and actuators from the field (fully modular connection consisting of front connector modules, connection cables and I/O modules), as well as easy wiring inside the control cabinet (flexible connection consisting of front connectors with assembled single conductors).

## System diagnostics and alarms

Integrated system diagnostics is activated by default for the CPUs. The different diagnostic types are configured instead of programmed. System diagnostics information and messages from the drives are displayed consistently in plain text in up to three languages:

- On the CPU display
- In STEP 7
- On the HMI
- On the web server

This information is available in RUN mode, but also in STOP mode of the CPU. An automatic update of the diagnostics information is performed when you configure new hardware components.

The CPU is available as a central interrupt server in up to three project languages. The HMI takes over the display in the project languages defined for the CPU. If you require alarm texts in additional languages, you can load them into your HMI via the configured connection. The CPU, STEP 7 and your HMI ensure data consistency without additional engineering steps. The maintenance work is easier.

### 3.3 Hardware properties

#### Article number

6ES7518-4AX00-1AB0

#### View of the module

The figure below shows the CPU 1518-4 PN/DP MFP.



Figure 3-2 CPU 1518-4 PN/DP MFP

---

#### NOTE

##### Protective film

Note that there is a removable protective foil on the display when the CPUs are delivered.

---

#### Properties

The CPU 1518-4 PN/DP MFP has the following properties:

Property	Description	Additional information
CPU display	All CPUs of the SIMATIC S7-1500 product series feature a display with plain text information. The display provides information on order numbers, firmware version and serial numbers of all connected modules. In addition, you can set the IP address of the CPU and make additional network settings. The display shows error messages directly as plain text.	<ul style="list-style-type: none"> <li>S7-1500, ET 200MP system manual  <a href="https://support.industry.siemens.com/cs/ww/en/view/59191792">https://support.industry.siemens.com/cs/ww/en/view/59191792</a> </li> </ul>



Property	Description	Additional information
	In addition to the functions listed here, a multitude of other functions that are described in the SIMATIC S7-1500 Display Simulator are shown on the display.	<ul style="list-style-type: none"> <li>SIMATIC S7-1500 Display Simulator (<a href="https://support.industry.siemens.com/cs/ww/en/view/109761758">https://support.industry.siemens.com/cs/ww/en/view/109761758</a>)</li> </ul>
<b>Supply voltage</b>	The 24 V DC supply voltage is fed via a 4-pin plug located on the front of the CPU.	<ul style="list-style-type: none"> <li>Section Connecting up (Page 40)</li> <li>S7-1500, ET 200MP system manual (<a href="https://support.industry.siemens.com/cs/ww/en/view/59191792">https://support.industry.siemens.com/cs/ww/en/view/59191792</a>)</li> </ul>
<b>PROFINET IO</b>		
PROFINET interface (X1 P1 R and X1 P2 R)	The interface has two ports. In addition to basic PROFINET functionality, it also supports PROFINET IO RT (real time) and IRT (isochronous real time).	PROFINET function manual ( <a href="https://support.industry.siemens.com/cs/ww/en/view/49948856">https://support.industry.siemens.com/cs/ww/en/view/49948856</a> )
PROFINET interface (X2 P1)	The interface has one port. In addition to basic PROFINET functionality, it also supports PROFINET IO RT (real time).	
PROFINET interface (X3 P1)	The interface is (typically) used to: <ul style="list-style-type: none"> <li>Link development tools for C/C++ applications</li> <li>Connect the TIA Portal to the development of STEP 7 applications</li> <li>Communicate to the "outside world" from C/C++ Runtime</li> <li>Communicate internally between C/C++ and CPU Runtime (via virtual network)</li> </ul>	SIMATIC S7-1500 ODK 1500S manual ( <a href="https://support.industry.siemens.com/cs/ww/en/ps/13914/man">https://support.industry.siemens.com/cs/ww/en/ps/13914/man</a> )
Operation of the CPU as <ul style="list-style-type: none"> <li>IO controller</li> <li>I-device</li> </ul>	<ul style="list-style-type: none"> <li><b>IO controller:</b> As an IO controller, the CPU addresses the connected IO devices</li> <li><b>I-device</b> As an I-device (intelligent IO device), the CPU is assigned to a higher-level IO controller and is used as an intelligent pre-processing unit for subroutines</li> </ul>	PROFINET function manual ( <a href="https://support.industry.siemens.com/cs/ww/en/view/49948856">https://support.industry.siemens.com/cs/ww/en/view/49948856</a> )
<b>PROFIBUS DP</b>		
PROFIBUS interface (X4)	The interface is used for connecting to a PROFIBUS network.	PROFIBUS ( <a href="https://support.industry.siemens.com/cs/ww/en/view/59193579">https://support.industry.siemens.com/cs/ww/en/view/59193579</a> ) function manual
Operation of the CPU as a DP master	In the role as a DP master, the CPU addresses the connected DP slaves. It is not possible for the CPU to take the role of a DP slave.	

## Accessories

You can find information on "Accessories/spare parts" in the S7-1500, ET 200MP system manual (<https://support.industry.siemens.com/cs/ww/en/view/59191792>).

## 3.4 Firmware functions

### Functions

CPU 1518-4 PN/DP MFP supports the following functions:

Function	Description	Additional information
<b>C/C++ applications</b>	<p>The CPU 1518-4 PN/DP MFP can execute STEP 7 blocks as well as blocks and applications programmed with C/C++ (CPU function library) in the user program. You can create the CPU function library and Linux C/C++ Runtime application with the "ODK 1500S Open Development Kit" (ODK). Using the ODK provides you with the mechanisms of higher programming languages (e.g. object-oriented) within a modern programming environment. You can use Target 1500S for Simulink and ODK 1500S to create CPU function libraries in C/C++ for your complex open and closed-loop control.</p>	<p>S7-1500 Open Development Kit 1500S programming and operating manual  <a href="https://support.industry.siemens.com/cs/ww/en/view/109783714">https://support.industry.siemens.com/cs/ww/en/view/109783714</a></p> <p>SIMATIC S7-1500 Target 1500S for Simulink programming manual  <a href="https://support.industry.siemens.com/cs/ww/en/view/109741754">https://support.industry.siemens.com/cs/ww/en/view/109741754</a></p>
<b>Integrated system diagnostics</b>	<p>The system automatically generates the alarms for system diagnostics and outputs the alarms via a programming device/PC, HMI device, the web server or the integrated display. System diagnostics information is also available when the CPU is in STOP mode.</p>	<p>Diagnostics function manual  <a href="https://support.industry.siemens.com/cs/ww/en/view/59192926">https://support.industry.siemens.com/cs/ww/en/view/59192926</a></p>
<b>Integrated web server</b>	<p>The web server allows you to access CPU data over a network. Evaluations, diagnostics, and modifications are thus possible over long distances. Monitoring and evaluation is possible without STEP 7; only a web browser is required. Make sure that you take appropriate measures (e.g. limiting network access, using firewalls) to protect the CPU from being compromised.</p>	<ul style="list-style-type: none"> <li>Web server Function Manual  <a href="https://support.industry.siemens.com/cs/ww/en/view/59193560">https://support.industry.siemens.com/cs/ww/en/view/59193560</a></li> <li>Security for SIMATIC S7 Controllers system manual  <a href="https://support.industry.siemens.com/cs/ww/en/view/90885010">https://support.industry.siemens.com/cs/ww/en/view/90885010</a></li> </ul>
<b>Integrated trace functionality</b>	<p>The trace functionality supports the troubleshooting and/or optimization of the user program. You record device tags and evaluate the recordings with the trace and logic analyzer function. Tags are, for example, drive parameters or system and user tags of a CPU. The device saves the traces. If necessary, you can read the traces with the configuration system (ES) and save them permanently. Thus, the trace and logic analyzer function is suitable for monitoring highly dynamic processes. The trace recording can also be displayed via the web server. With the project trace, you record the tags of multiple devices within a project, for example, a controller and a drive. With the long-term trace, you record up to 64 different tags for each cycle in a .csv file over an extended period (e.g. hours, days).</p>	<p>Function manual for trace and logic analyzer function  <a href="https://support.industry.siemens.com/cs/ww/en/view/64897128">https://support.industry.siemens.com/cs/ww/en/view/64897128</a></p>

Function	Description	Additional information
<b>OPC UA</b>	With OPC UA, you can exchange data via an open and manufacturer-neutral communication protocol. The CPU can act as OPC UA server. The CPU acting as the OPC UA server can communicate with OPC UA clients. In turn, the CPU can access an OPC UA server as OPC UA client, allow the OPC UA server to run methods and read out information from the OPC UA server. The OPC UA Companion Specification allows methods to be specified uniformly and independently of the manufacturer. Using these specified methods, you can easily integrate devices from various manufacturers into your plants and production processes.	Communication function manual ( <a href="https://support.industry.siemens.com/cs/ww/en/view/59192925">https://support.industry.siemens.com/cs/ww/en/view/59192925</a> )
<b>Configuration control</b>	The configuration control allows you to handle different real hardware configurations with a maximum hardware configuration. Especially in series machine manufacturing, this means that you have the option of operating/configuring different expansion variants of a machine within a single project.	S7-1500, ET 200MP system manual ( <a href="https://support.industry.siemens.com/cs/ww/en/view/59191792">https://support.industry.siemens.com/cs/ww/en/view/59191792</a> )
<b>PROFINET IO</b>		
RT (real time)	RT prioritizes PROFINET IO message frames over standard message frames. This ensures the required determinism in the automation technology. The data is transferred via prioritized Ethernet frames.	PROFINET function manual ( <a href="https://support.industry.siemens.com/cs/ww/en/view/49948856">https://support.industry.siemens.com/cs/ww/en/view/49948856</a> )
IRT (isochronous real time)	A reserved bandwidth is available within the send clock for the IRT data. The reserved bandwidth ensures that the IRT data can be transmitted in time-synchronized intervals, unaffected by other high network loads (e.g. TCP/IP communication or additional real time communication). IRT enables update times to be achieved with the highest deterministic. IRT makes isochronous applications possible.	
Isochronous mode	The clock synchronization system characteristic acquires measured values and process data and processes the signals within a fixed system clock. Isochronous mode thus contributes to high control quality and hence to greater manufacturing precision. Isochronous mode reduces potential fluctuations of the process reaction times to a minimum. Time-assured processing enables higher machine clocks to be achieved.	
MRP (Media Redundancy Protocol)	The Media Redundancy Protocol makes it possible to build redundant networks. Redundant transmission paths (ring topology) ensure that an alternative communication path is made available if one transmission path fails. The PROFINET devices that are part of this redundant network form an MRP domain. RT mode is possible when using MRP.	
MRPD (Media Redundancy with Planned Duplication)	The MRP extension, MRPD, has the advantage that if a device or a line in the ring fails, all other devices are continuously supplied with IO data without interruption and with fast update times. MRPD is based on IRT and MRP. To realize media redundancy with short update times, the PROFINET devices participating in the ring send their data in both directions.	

3.4 Firmware functions

Function	Description	Additional information
	The devices receive this data at both ring ports so that there is no reconfiguration time.	PROFINET function manual ( <a href="https://support.industry.siemens.com/cs/ww/en/view/49948856">https://support.industry.siemens.com/cs/ww/en/view/49948856</a> )
MRP interconnection	The MRP interconnection process is an enhancement of MRP and allows the redundant coupling of two or more rings with MRP in PROFINET networks. MRP interconnection is - like MRP - specified in the IEC 62439-2 standard (Edition 3).	
Shared device	The "Shared device" function allows you to distribute the modules or submodules of an IO device to different IO controllers. Numerous IO controllers are often used in larger or widely distributed systems. Without the "Shared device" function, each I/O module of an IO device is assigned to the same IO controller. Therefore, if sensors close in distance to one another have to supply data to different IO controllers, several IO devices are required. The "Shared device" function allows you to distribute the modules or submodules of an IO device to different IO controllers, thus allowing flexible automation concepts. You can, for example, combine I/O modules lying near one other in one IO device.	
PROFenergy	PROFenergy is a PROFINET-based data interface for switching off consumers centrally and with full coordination during pause times regardless of the manufacturer or device type. Through this, the process should only be provided with the energy that is absolutely required. The majority of the energy is saved by the process; the PROFINET device itself only contributes a few watts of savings potential.	
<b>Integrated technology</b>		
Motion control	S7-1500 CPUs support the controlled positioning and traveling of axes via S7-1500 Motion Control functions by means of the following technology objects: Speed axes, positioning axes, synchronous axes, external encoders, output cams, cam tracks, and measuring inputs <ul style="list-style-type: none"> <li>• Speed-controlled axis for controlling a drive with speed specification</li> <li>• Positioning axis for position-controlled positioning of a drive</li> <li>• Synchronous axis to interconnect with a master value. The axis follows the synchronous operation of the position of the leading axis</li> <li>• External encoder for detecting the actual position of an encoder and its use as a master value for synchronous operation</li> <li>• Cams, cam track for position-dependent generation of switching signals</li> <li>• Measuring input for fast, accurate and event-dependent sensing of actual positions</li> </ul>	S7-1500T Motion Control function manuals ( <a href="https://support.industry.siemens.com/cs/ww/en/view/109751049">https://support.industry.siemens.com/cs/ww/en/view/109751049</a> )
Integrated closed-loop control functionality	<ul style="list-style-type: none"> <li>• PID Compact (continuous PID controller)</li> <li>• PID 3Step (step controller for integrating actuators)</li> <li>• PID Temp (temperature controller for heating and cooling with two separate actuators)</li> </ul>	PID Control function manual ( <a href="https://support.industry.siemens.com/cs/ww/en/view/108210036">https://support.industry.siemens.com/cs/ww/en/view/108210036</a> )

Function	Description	Additional information
<b>Integrated safety</b>		
Secure PG/HMI communication	With STEP 7 and WinCC, SIMATIC S7-1500 CPUs and ET 200 CPUs support innovated and standardized secure PG/PC and HMI communication – referred to as Secure PG/HMI communication for short.	Communication function manual ( <a href="https://support.industry.siemens.com/cs/de/de/view/59192925/en">https://support.industry.siemens.com/cs/de/de/view/59192925/en</a> )
Protection of confidential configuration data	You have the option of assigning a password for protecting confidential configuration data of the respective CPU. This refers to data such as private keys that are required for the proper functioning of certificate-based protocols.	
Integrity protection	The CPUs feature an integrity protection function by default. This helps to detect any manipulation of the engineering data on the SIMATIC Memory Card or during data transfer between the TIA Portal and the CPU, and to check communication from a SIMATIC HMI system to the CPU for possible manipulation of engineering data. The user receives a corresponding message about manipulation of engineering data detected by the integrity protection.	S7-1500, ET 200MP system manual ( <a href="https://support.industry.siemens.com/cs/ww/en/view/59191792">https://support.industry.siemens.com/cs/ww/en/view/59191792</a> )
Know-how protection	The know-how protection protects user blocks against unauthorized access and modifications.	
Copy protection	Copy protection links user blocks with the serial number of one or more SIMATIC Memory Cards or the serial number of one or more CPUs. User programs cannot run without the corresponding SIMATIC Memory Card or CPU.	
Local user management (as of FW version V3.1)	Improved management of users, roles, and CPU function rights (User Management & Access Control, UMAC). You can use the local user management in the editor to manage all project users along with their rights (e.g. access rights) for users and roles of the project in the TIA Portal.	
Access protection (up to FW version V3.0)	You can assign separate rights to different users via authorization levels.	
Password provider	As an alternative to manual password entry, you can link a password provider to STEP 7. A password provider provides the following advantages: <ul style="list-style-type: none"> <li>• Convenient handling of passwords. STEP 7 automatically reads in the password for the blocks. This saves you time.</li> <li>• Optimal block protection, since the users do not know the password themselves.</li> </ul>	

### 3.4.1 Quick start instructions for commissioning C/C++ Runtime

---

**NOTE**
**Commissioning the C/C++ Runtime**

You require experience in working with Linux systems to commission the C/C++ Runtime.

---

**Two IP addresses of the PROFINET interface X3 P1**

The PROFINET interface X3 P1 is (typically) used to:

- Link development tools for C/C++ Runtime applications
- Connect the TIA Portal
- Develop STEP 7 applications
- Communicate from C/C++ Runtime
- Communicate internally between C/C++ and CPU Runtime (via virtual network)

The PROFINET interface X3 P1 is split internally for the CPU Runtime and the C/C++ Runtime. Therefore, there is one IP address for the CPU and one IP address for the C/C++ Runtime.

- Set the IP address of the CPU in STEP 7.  
You can find additional information in the online help for STEP 7.
- Set the IP address of the C/C++ Runtime in the configuration file of the C/C++ Runtime (see the section "Initial commissioning").

Note the following restrictions when configuring the PROFINET interface X3 P1 with STEP 7:

- The configuration of the "Transmission rate/duplex" has no effect on the connection to the PROFINET interface X3 P1 and the C/C++ Runtime.
- The "Monitor" option is not supported.
- Topology configuration is not supported.

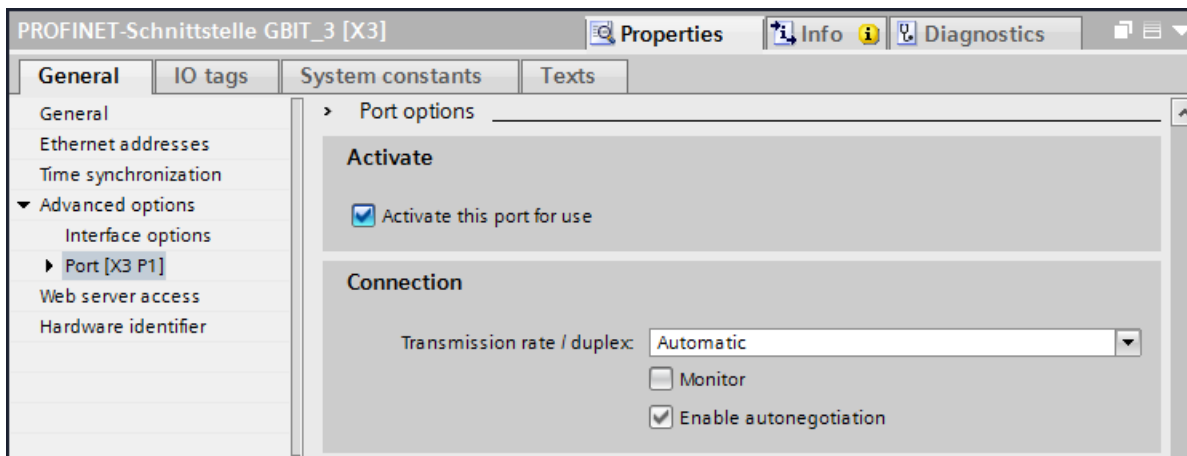

Figure 3-3 Port options in STEP 7

---

**NOTE**
**Availability of the X3 interface**

Interface X3 is available only after approximately 1 to 2 minutes after POWER ON of the CPU.

---

## Initial commissioning

### Minimum requirement

SIMATIC memory card with a capacity of at least 2 GB.

### Procedure

Proceed as follows to commission the C/C++ Runtime:

1. Start a Secure Shell Client (e.g. PuTTY).
2. Connect the Secure Shell Client to the CPU 1518(F)-4 PN/DP MFP using the PuTTY configuration "CPU 1518MFP Linux Secure Connection" via the target address (default address: 192.168.15.18).
3. Type in the user name and password and establish a Secure Shell Connection.  
The default user name is "root". The default password is displayed under "Overview > MFP > Default Password".
4. Change the default password after the first startup of the CPU.
5. Change the IP address or configure DHCP using the "bridge.network" script in the "/etc/systemd/network" directory by entering the following commands in the given sequence.
  - "cd /etc/systemd/network" to switch to the specified directory.
  - "ls -l" to list all the files/directories in this directory.
  - "pico bridge.network" to open the script "bridge.network" in the Pico text editor.
  - Change the IP address settings in the script.
  - Press CTRL + X to exit the text editor.
  - Press CTRL + Y to select overwriting of the script.
  - Press ENTER to save the change and close the text editor.
6. Transfer your configuration to the memory card and load the "systemd networkd" module once again by calling "sync && systemctl restart systemd-networkd" as the root user.
7. Create your own user account in the Linux subsystem without root privileges. Work with this user account.

---

### NOTE

#### Extending the service life of storage media

When you modify files in the Linux file system, use the "sync" command to write important data immediately to the containers of the memory card.

If you do not use the "sync" command, the changed data will be automatically transferred to the memory card with a delay of approximately 40 seconds. In this manner, you can extend the service life of your SIMATIC memory card.

---

You can find more information on configuring PuTTY and creating C/C++ Runtime applications in the SIMATIC S7-1500 ODK 1500S

(<https://support.industry.siemens.com/cs/ww/en/ps/13914/man>) manual.

## Security information

---

### NOTE

- Follow the Principle of Least Privilege.
  - Start your application as a user without root privileges.
  - Configure the SSH server in Linux Runtime in such a way that it only permits certificate-based authentication. Disable password-based authentication for all users.
  - Change the user passwords regularly and use secure passwords.
- 

---

### NOTE

#### IPv6 protocol

Note that for the CPU 1518(F)-4 PN/DP MFP, the IPv6 protocol is deactivated by default in the configuration file (`/usr/share/netfilter-persistent/plugins.d/12-ipv6-disable`). To use IPv6, remove this configuration file. Then carry out a restart so that the changes come into effect.

Ensure that your system is protected against unauthorized access by implementing appropriate protective measures, e.g. the use of firewalls. If you do not use the IPv6 protocol for communication, we recommend that you leave IPv6 deactivated.

---

## Mass storage concept

Keep in mind the following information on the storage locations on the SIMATIC memory card.

The following C/C++ Runtime containers are available in the `/C++Env1.MFP` directory on the SIMATIC memory card and are mounted in the file system in Linux as described:

- `User.img` (50 MB) → Mount point: `/home` (home directory of the user, for example, for C/C++ Runtime application)
- `Data.img` (200 MB) → mount point: `/` (root) as overlays

## Performing bulk operations

To use the same C/C++ Runtime application for other CPUs, transfer the C/C++ Runtime application to the home directory. The home directory is available in the `"User.img"` file on the SIMATIC memory card.

To use the C/C++ Runtime application on other CPUs, copy the `"User.img"` file to the corresponding SIMATIC memory cards.

## Work memory for C/C++ Runtime

The RAM is 1 GB including the RAM disk.



## Procedure for updates

For firmware updates from versions V2.5.2 to V2.8.x, create a backup of containers on the SIMATIC memory card in the directory "/C++Env1.MFP".

1. Carry out the operating system update to V2.8x. Format the SIMATIC memory card or delete the container from the folder "/C++Env1.MFP".
2. After starting the Linux subsystem, configure the subsystem according to your requirements.
3. Copy your application into the "/home/user" directory, from where you then start the application.

## ODK toolchain

---

### NOTE

#### ODK toolchain

We recommend compiling the user applications with the refurbished ODK toolchain.

Please also read the entries 109782620

(<https://support.industry.siemens.com/cs/ww/en/view/109782620>) and 109782540

(<https://support.industry.siemens.com/cs/ww/en/view/109782540>) on the Internet with regard to the ODK toolchain.

---

## Autostart of user programs

You can start applications automatically using systemd services. There are examples of this in the official systemd manual

(<https://www.freedesktop.org/software/systemd/man/systemd.service.html#Examples>).

## Special features

---

### NOTE

#### Initial startup with an empty SIMATIC memory card

When the CPU starts up for the first time with an empty SIMATIC memory card, the card is prepared for use with C/C++ Runtime. This process takes up to three minutes. Do not turn off the CPU during this phase; the STOP LED flashes.

---

---

### NOTE

#### Defective C/C++ Runtime containers

The three C/C++ Runtime containers are available in the "/C++Env1.MFP" directory on the SIMATIC memory card.

If the C/C++ Runtime containers are damaged or lost when the CPU is switched off, a diagnostic entry is created in the diagnostic buffer of the CPU the next time the CPU is started up. C/C++ Runtime cannot be reached, and the ERROR LED is flashing.

If automatic repair of the containers by the automation system is not possible, the containers can no longer be used by the Linux file system. The automation system starts C++ Runtime in root mode.

A new logon with the standard user and password is possible. However, you cannot make any permanent changes to the automation system, e.g:

- Change the password
- Save data
- Change system settings

#### Solution:

- Copy a previously created backup copy of the C/C++ Runtime containers to the SIMATIC memory card.  
or
  - Delete the affected C/C++ Runtime container from the SIMATIC memory card. The automation system then recreates the container during the next startup.
- 

---

### NOTE

#### Affecting the performance of the CPU

Depending on the type of programming, C/C++ Runtime applications, such as mass storage accesses to the SIMATIC memory card, can affect the performance of the CPU.

---

### 3.4.2 Supplied libraries for C/C++ Runtime

#### **glibc : 2.24**

The GNU C Library project provides the core libraries for the GNU system and GNU/Linux systems, as well as many other systems that use Linux as the kernel. These libraries provide critical APIs including ISO C11, POSIX.1-2008, BSD, OS-specific APIs and more. These APIs include such foundational facilities as open, read, write, malloc, printf, getaddrinfo, dlopen, pthread\_create, crypt, login, exit and more.

#### **libstdc++ : 6.2.0**

The GNU Standard C++ Library is an ongoing project to implement the ISO 14882 Standard C++ library as described in clauses 17 through 30 and annex D.

## 3.5 Operating and display elements

### 3.5.1 Front view of the CPU with the front panel

The figure below shows the front view of the CPU 1518-4 PN/DP MFP.

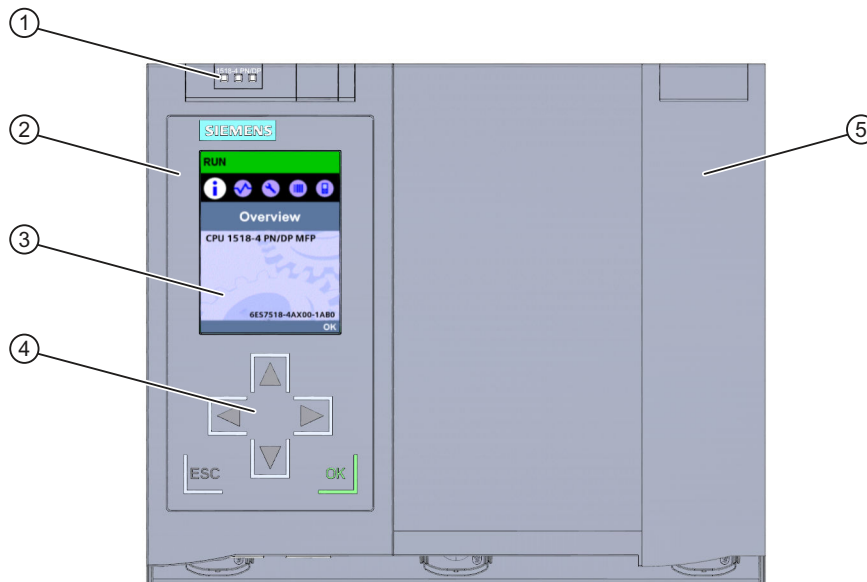

- ① LEDs for the current operating mode and diagnostic status of the CPU
- ② Front panel with display
- ③ Display
- ④ Operator control buttons
- ⑤ Front panel of the PROFIBUS interface

Figure 3-4 View of the CPU 1518-4 PN/DP MFP (with front panels) – front

#### NOTE

##### Temperature range for display

To increase its service life, the display switches off at a temperature below the permitted operating temperature of the device. When the display cools down again, it automatically switches itself on again. When the display is switched off, the LEDs continue to show the status of the CPU.

For more information on the temperatures at which the display switches itself on and off, refer to the Technical specifications ([Page 48](#)).

## Pulling and plugging the front panel with display

You can pull and plug the front panel with display during operation.

### WARNING

#### **Personal injury and damage to property may occur**

If you pull or plug the front panel of an S7-1500 automation system during operation, personal injury or damage to property can occur in zone 2 hazardous areas.

Before you remove or fit the front panel, always switch off the power supply to the S7-1500 automation system in hazardous area zone 2.

## Locking the front panel

You can lock the front panels to protect the SIMATIC memory card and the mode selector of the CPU against unauthorized access.

You can attach a security seal or a padlock with a diameter of 3 mm to the front panels.

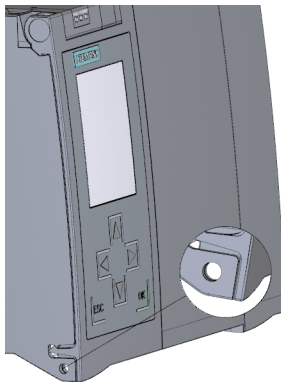

Figure 3-5 Locking latch on the CPU

In addition to the mechanical lock, you can also block access to a password-protected CPU on the display (local lock) and assign a password for the display. You can find additional information on the display, configurable protection levels and local locks in the S7-1500, ET 200MP (<https://support.industry.siemens.com/cs/ww/en/view/59191792>) system manual.

## Reference

You will find detailed information on the individual display options, a training course and a simulation of the available menu commands in the SIMATIC S7-1500 Display Simulator (<https://support.industry.siemens.com/cs/ww/en/view/109761758>).

### 3.5.2 Front view of the CPU without front panel

The figure below shows the operator controls and connection elements of the CPU 1518-4 PN/DP MFP.

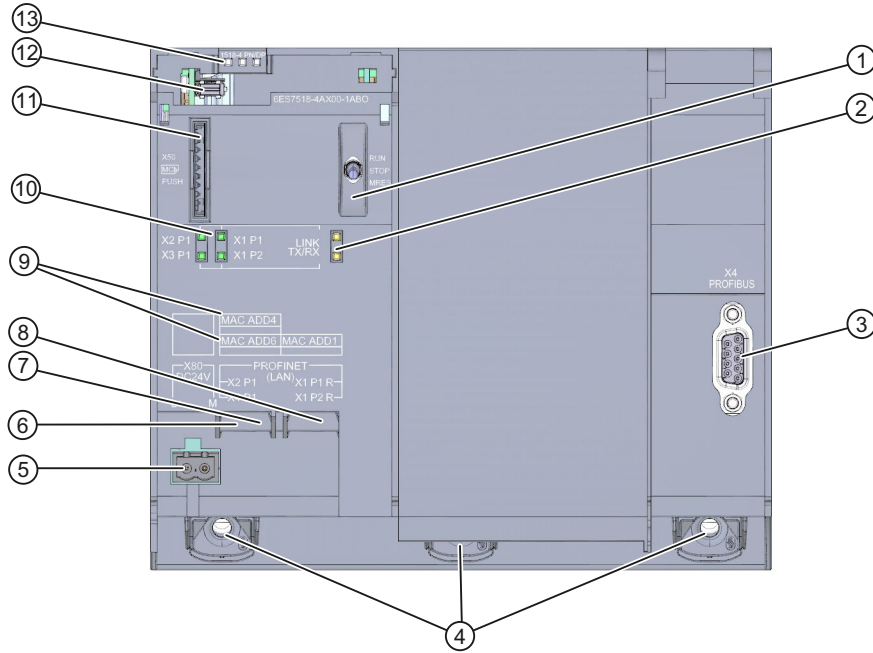

- ① Mode selector
- ② No function
- ③ PROFIBUS interface (X4)
- ④ Fixing screws
- ⑤ Connector for power supply
- ⑥ PROFINET IO interface (X3) with 1 port (back interface)
- ⑦ PROFINET IO interface (X2) with 1 port (front interface)
- ⑧ PROFINET IO interface (X1) with 2 ports
- ⑨ MAC addresses of the interfaces
- ⑩ LEDs for the 4 ports of the PROFINET interfaces X1, X2 and X3
- ⑪ Slot for the SIMATIC memory card
- ⑫ Display connector
- ⑬ LEDs for the current operating mode and diagnostic status of the CPU

Figure 3-6 View of the CPU 1518-4 PN/DP MFP (without front panels) – front

### 3.5.3 Rear view of the CPU

The following figure shows the connection elements on the rear of the CPU 1518-4 PN/DP MFP.

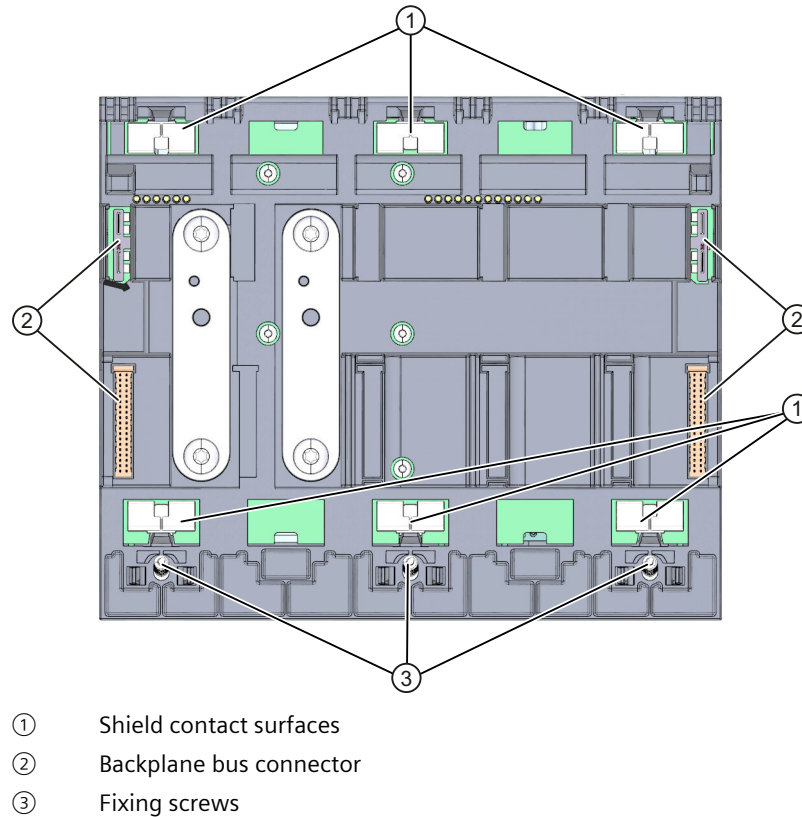

Figure 3-7 View of the CPU 1518-4 PN/DP MFP – rear

## 3.6 Mode selector switch

You use the mode selector to:

- Request a change to a specific operating state
- Disable or enable the change to a specific operating state  
(if, for example, the mode selector is set to STOP, you cannot switch the CPU to RUN via a communication task configured in the TIA Portal or via the display)

The following table shows the position of the switch and the corresponding meaning.

Table 3-6 Mode switch settings

Position	Meaning	Explanation
RUN	RUN mode	The CPU has permission to go to RUN.
STOP	STOP mode	The CPU does not have permission to go to RUN.
MRES	Memory reset	Position for CPU memory reset.

## Connecting up

This section provides information on the terminal assignment of the individual interfaces and the block diagram of the CPU 1518-4 PN/DP MFP.

### 24 V DC supply voltage (X80)

The connector for the power supply is plugged in when the CPU ships from the factory. The following table shows the signal names and the descriptions of the pin assignment for a 24 V DC supply voltage.

Table 4-1 Pin assignment 24 V DC supply voltage

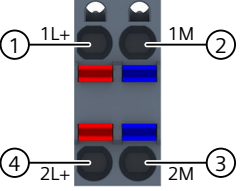
View	Signal name <sup>1)</sup>		Designation
Connector			
	1	1L+	+ 24 V DC of the supply voltage
	2	1M	Ground of the supply voltage
	3	2M	Ground of the supply voltage for loop-through <sup>2)</sup>
	4	2L+	+ 24 V DC of the supply voltage for loop-through <sup>2)</sup>

<sup>1)</sup> 1L+ and 2L+ as well as 1M and 2M are bridged internally.

<sup>2)</sup> Maximum 10 A permitted

If the CPU is supplied by a system power supply, it is not necessary to connect the 24 V supply.

### PROFINET interface X1 with 2-port switch (X1 P1R and X1 P2R)

The assignment corresponds to the Ethernet standard for a RJ45 connector.

- When autonegotiation is deactivated, the RJ45 socket is allocated as a switch (MDI-X).
- When autonegotiation is activated, autocrossing is in effect and the RJ45 socket is allocated either as data terminal equipment (MDI) or a switch (MDI-X).

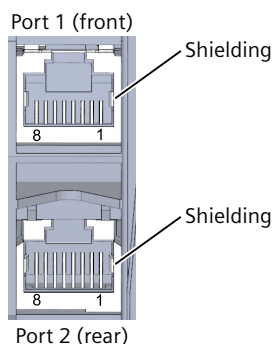

Figure 4-1 Interface assignment X1



## PROFINET interface X2 and X3 with 1 port (X2 P1, X3 P1)

The assignment corresponds to the Ethernet standard for a RJ45 connector. Autocrossing is always active on X2 and X3. This means the RJ45 socket is allocated either as data terminal equipment (MDI) or a switch (MDI-X).

X2 Port 1(front)

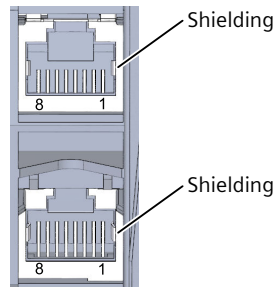

X3 Port 1(rear)

Figure 4-2 Interfaces X2 and X3

### NOTE

#### PROFINET interface X3 with a transmission rate of 1000 Mbps

The PROFINET interface X3 supports a maximum transmission rate of 1000 Mbps.

Requirements:

- Devices on the PROFINET segment must support the 1000 Mbps transmission rate.
- The network infrastructure (network cables and outlets) must be category CAT 5e or higher.
- The "Transmission rate" parameter in the properties of the port (X3) must be set as follows in STEP 7:
  - The "Autonegotiation" check box is selected
  - "Automatic" is selected in the drop-down list

## PROFIBUS interface X4

The table below shows the terminal assignment of the PROFIBUS interface. The assignment corresponds to the standard assignment of an RS485 interface.

Table 4-2 PROFIBUS interface terminal assignment

View	Signal name		Designation
	1	-	-
	2	-	-
	3	RxD/TxD-P	Data line B
	4	RTS	Request To Send
	5	M5V2	Data reference potential (from station)
	6	P5V2	Supply plus (from station)

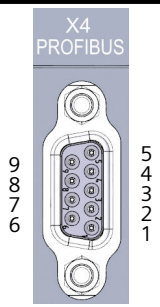
View	Signal name		Designation
 <p>X4 PROFIBUS</p>	7	-	-
	8	RxD/TxD-N	Data line A
	9	-	-

**NOTE**

**Supply of I/O devices**

The CPU 1518-4 PN/DP MFP does not provide a 24 V DC power supply on the PROFIBUS interface. I/O devices (for example, PC adapter USB 6ES7972-0CB20-0XA0) are only operational on the interface in conjunction with a plug-in power supply set for external power supply.

The innovative successor product, PC adapter USB A2, receives the required power supply via the USB port. This means it does not need a 24 V DC supply voltage and can be operated **without** a plug-in power supply set for external power supply.

**Reference**

You can find additional information on the topics of "Connecting the CPU" and "Accessories/spare parts" in the S7-1500, ET 200MP (<https://support.industry.siemens.com/cs/ww/en/view/59191792>) system manual.

**Assignment of the MAC addresses**

The CPU 1518-4 PN/DP MFP has three PROFINET interfaces. The first interface is an interface with 2-port switch. The PROFINET interfaces each have a MAC address, and each of the PROFINET ports has its own MAC address. The CPU 1518-4 PN/DP MFP therefore has seven MAC addresses in total.

The MAC addresses of the PROFINET ports are needed for the LLDP protocol, for example for the neighborhood discovery function.

The number range of the MAC addresses is sequential. The first and last MAC addresses are lasered on the rating plate on the right side of each CPU 1518-4 PN/DP MFP.

The table below shows how the MAC addresses are assigned.

Table 4-3 Assignment of the MAC addresses

	Assignment	Labeling
<b>MAC address 1</b>	PROFINET interface X1 (visible in STEP 7 for accessible devices)	<ul style="list-style-type: none"> <li>• Front printed</li> <li>• Right side printed (start of number range)</li> </ul>
<b>MAC address 2</b>	Port X1 P1R (required for LLDP, for example)	---
<b>MAC address 3</b>	Port X1 P2R (required for LLDP, for example)	---

	<b>Assignment</b>	<b>Labeling</b>
<b>MAC address 4</b>	PROFINET interface X2 (visible in STEP 7 for accessible devices)	Front printed
<b>MAC address 5</b>	Port X2 P1 (required for LLDP, for example)	---
<b>MAC address 6</b>	PROFINET interface X3 (visible in STEP 7 for accessible devices)	Front printed
<b>MAC address 7</b>	Port X3 P1 (for C/C++ Runtime applications)	<ul style="list-style-type: none"><li>• Front printed</li><li>• Right side printed (end of number range)</li></ul>

### Block diagram

The figure below shows the schematic circuit diagram of the CPU 1518-4 PN/DP MFP.

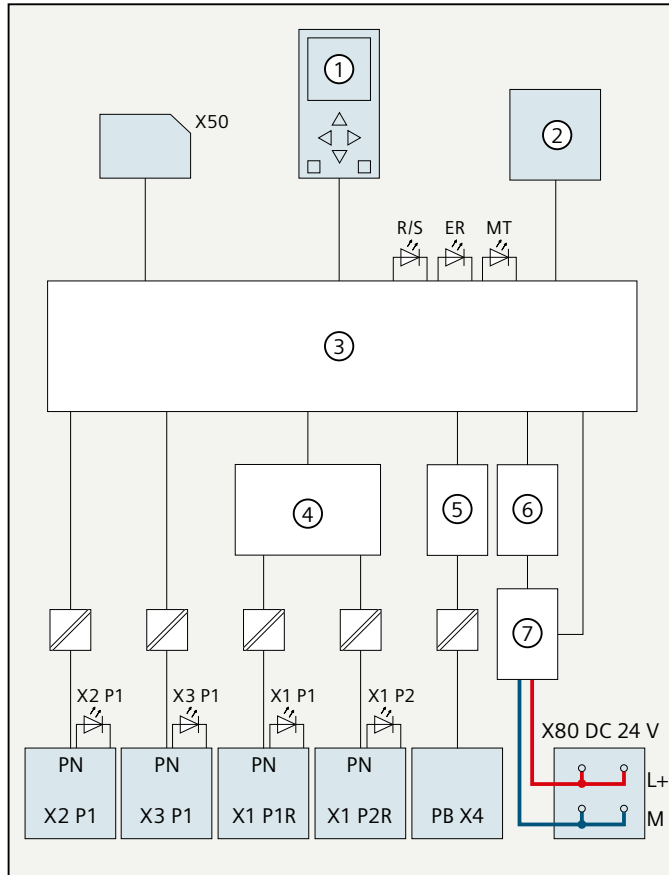

①	Display	PN X1 P2R	PROFINET interface X1 Port 2
②	RUN/STOP/MRES mode selector switch	PN X2 P1	PROFINET interface X2 Port 1
③	Electronics	PN X3 P1	PROFINET interface X3 Port 1
④	PROFINET 2-port switch	PB X4	PROFIBUS interface X4
⑤	PROFIBUS DP driver	L+	24 V DC supply voltage
⑥	Backplane bus interface	M	Ground
⑦	Internal supply voltage	R/S	RUN/STOP LED (yellow/green)
X50	SIMATIC Memory Card	ER	ERROR LED (red)
X80 24 V DC	Infeed of supply voltage	MT	MAINT LED (yellow)
PN X1 P1R	PROFINET interface X1 Port 1	X1 P1, X1 P2, X2 P1, X3 P1	LED link TX/RX

Figure 4-3 Block diagram of the CPU 1518-4 PN/DP MFP

# Interrupts, error messages, diagnostics and system alarms

# 5

The status and error displays of the CPU 1518-4 PN/DP MFP are described below. You will find additional information on "Interrupts" in the STEP 7 online help. You can find additional information on the topics of "Diagnostics" and "System alarms" in the Diagnostics (<https://support.industry.siemens.com/cs/ww/en/view/59192926>) function manual.

## 5.1 Status and error display of the CPU

### LED display

The figure below shows the LED displays of the CPU 1518-4 PN/DP MFP.

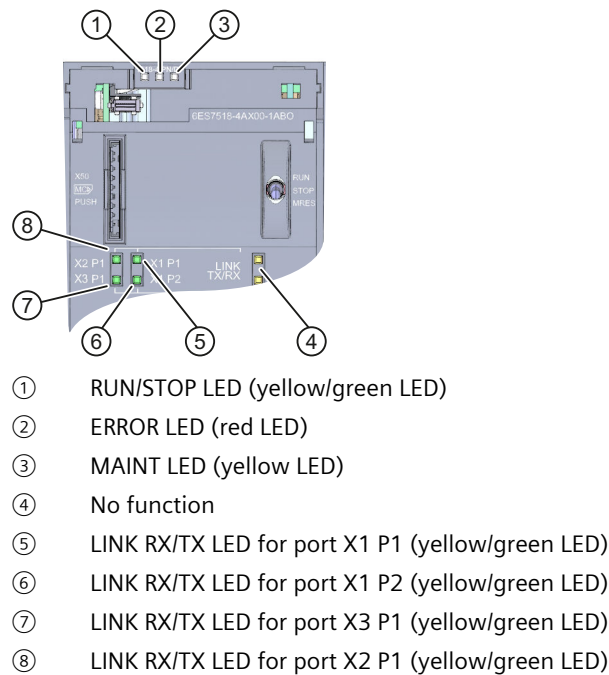





































Figure 5-1 LED display of the CPU 1518-4 PN/DP MFP (without front panel)

### Meaning of the RUN/STOP, ERROR and MAINT LEDs

The CPU 1518-4 PN/DP MFP has three LEDs for displaying the current operating mode and diagnostics status. The following table shows the meaning of the various combinations of colors for the RUN/STOP, ERROR and MAINT LEDs.

Table 5-1 Meaning of the LEDs





RUN/STOP LED	ERROR LED	MAINT LED	Meaning
 LED off	 LED off	 LED off	Missing or insufficient power supply on the CPU.
 LED off	 LED flashes red	 LED off	An error has occurred.
 LED lit green	 LED off	 LED off	CPU is in RUN mode.
 LED lit green	 LED off	 LED lit yellow	Maintenance demanded for the plant. You need to check/replace the affected hardware within a short period of time.
			Active Force job
			OPC UA server of the CPU expects initial trust lists and CRLs via GDS Push function.
 LED lit green	 LED off	 LED flashes yellow	Bad configuration
 LED lit yellow	 LED flashes red	 LED off	A diagnostics event is pending.
 LED lit yellow	 LED off	 LED flashes yellow	Firmware update using SIMATIC memory card successfully completed.
 LED lit yellow	 LED off	 LED off	CPU is in STOP mode.
			CPU runs a program with active breakpoints. The program is at a breakpoint.
 LED lit yellow	 LED flashes red	 LED flashes yellow	The program on the SIMATIC memory card is causing an error.
			Firmware update using SIMATIC memory card has failed.
			The CPU has detected an error state. Additional information is available via the CPU diagnostic buffer.
 LED flashes yellow	 LED off	 LED off	CPU is performing internal activities during STOP, e.g. startup after STOP.
			Download of the user program from the SIMATIC memory card
			CPU executes a program with an enabled breakpoint. The program is presently moving from one breakpoint to another.
			Firmware update is being performed.
 LED flashes yellow/green	 LED off	 LED off	Startup (transition from STOP → RUN)

RUN/STOP LED	ERROR LED	MAINT LED	Meaning
 LED flashes yellow/green	 LED flashes red	 LED flashes yellow	Startup (CPU booting)
			Test of LEDs during startup, inserting a module.
			LED flashing test

### Meaning of LINK RX/TX LED

Each port has a LINK RX/TX LED. The table below shows the various "LED scenarios" of the CPU 1518-4 PN/DP MFP ports.

Table 5-2 Meaning of the LEDs

LINK TX/RX LED	Meaning
 LED off	There is no Ethernet connection between the PROFINET interface of the PROFINET device and the communication partner. No data is currently being sent/received via the PROFINET interface. There is no LINK connection.
 LED flashes green	The CPU is performing an "LED flash test".
 LED lit green	There is an Ethernet connection between the PROFINET interface of your PROFINET device and a communication partner.
 LED flashes yellow/green	Data is currently being received from or sent to a communications partner on Ethernet via the PROFINET interface of the PROFINET device.

#### NOTE

##### "LED" instruction

You can read the status (e.g. "On" or "Off") of LEDs of a CPU or a module using the "LED" instruction. Note, however, that it is not possible to read the LED status of the LINK RX/TX LEDs on all S7-1500 CPUs.

You can find additional information on the "LED" instruction in the STEP 7 online help.

## Technical specifications

The following table shows the technical specifications as of 11/2023. You will find a data sheet including daily updated technical specifications on the Internet (<https://support.industry.siemens.com/cs/ww/en/pv/6ES7518-4AX00-1AB0/td?dl=en>).

<b>Article number</b>	<b>6ES7518-4AX00-1AB0</b>
<b>General information</b>	
Product type designation	CPU 1518-4 PN/DP MFP
HW functional status	FS04
Firmware version	V3.1
<ul style="list-style-type: none"> <li>FW update possible</li> </ul>	Yes
<b>Product function</b>	
<ul style="list-style-type: none"> <li>I&amp;M data</li> </ul>	Yes; I&M0 to I&M3
<ul style="list-style-type: none"> <li>Isochronous mode</li> </ul>	Yes; Distributed and central; with minimum OB 6x cycle of 125 $\mu$ s (distributed) and 1 ms (central)
<ul style="list-style-type: none"> <li>SysLog</li> </ul>	Yes
<b>Engineering with</b>	
<ul style="list-style-type: none"> <li>STEP 7 TIA Portal configurable/integrated from version</li> </ul>	V19 (FW V3.1) / V15 (FW V2.5) or higher
<b>Configuration control</b>	
via dataset	Yes
<b>Display</b>	
Screen diagonal [cm]	6.1 cm
<b>Control elements</b>	
Number of keys	6
Mode selector switch	1
<b>Supply voltage</b>	
Rated value (DC)	24 V
permissible range, lower limit (DC)	19.2 V
permissible range, upper limit (DC)	28.8 V
Reverse polarity protection	Yes
<b>Mains buffering</b>	
<ul style="list-style-type: none"> <li>Mains/voltage failure stored energy time</li> </ul>	5 ms
<ul style="list-style-type: none"> <li>Repeat rate, min.</li> </ul>	1/s
<b>Input current</b>	
Current consumption (rated value)	1.7 A
Current consumption, max.	2 A
Inrush current, max.	2 A; Rated value
$I^2t$	0.4 A <sup>2</sup> -s



<b>Article number</b>	<b>6ES7518-4AX00-1AB0</b>
<b>Power</b>	
Infeed power to the backplane bus	12 W
Power consumption from the backplane bus (balanced)	35 W
<b>Power loss</b>	
Power loss, typ.	29 W
<b>Memory</b>	
Number of slots for SIMATIC memory card	1
SIMATIC memory card required	Yes
<b>Work memory</b>	
<ul style="list-style-type: none"> <li>integrated (for program)</li> </ul>	6 Mbyte
<ul style="list-style-type: none"> <li>integrated (for data)</li> </ul>	60 Mbyte
<ul style="list-style-type: none"> <li>integrated (for CPU function library of CPU Runtime)</li> </ul>	50 Mbyte; Note: The "CPU function library of the CPU" are C/C++ blocks for the user program that were created using the SIMATIC ODK 1500S or Target 1500S.
<b>Working memory for additional functions</b>	
<ul style="list-style-type: none"> <li>Integrated (for C/C++ Runtime application)</li> </ul>	1 024 Mbyte
<ul style="list-style-type: none"> <li>available (for Linux runtime application)</li> </ul>	1 Gbyte
<b>Load memory</b>	
<ul style="list-style-type: none"> <li>Plug-in (SIMATIC Memory Card), max.</li> </ul>	32 Gbyte; the memory card must have at least 2 GB of space on it
<b>Backup</b>	
<ul style="list-style-type: none"> <li>maintenance-free</li> </ul>	Yes
<b>CPU processing times</b>	
for bit operations, typ.	1 ns
for word operations, typ.	2 ns
for fixed point arithmetic, typ.	2 ns
for floating point arithmetic, typ.	6 ns
<b>CPU-blocks</b>	
Number of elements (total)	20 000; Blocks (OB, FB, FC, DB) and UDTs
<b>DB</b>	
<ul style="list-style-type: none"> <li>Number range</li> </ul>	1 ... 60 999; subdivided into: number range that can be used by the user: 1 ... 59 999, and number range of DBs created via SFC 86: 60 000 ... 60 999
<ul style="list-style-type: none"> <li>Size, max.</li> </ul>	16 Mbyte; For DBs with absolute addressing, the max. size is 64 KB
<b>FB</b>	
<ul style="list-style-type: none"> <li>Number range</li> </ul>	0 ... 65 535
<ul style="list-style-type: none"> <li>Size, max.</li> </ul>	1 Mbyte

Article number	6ES7518-4AX00-1AB0
<b>FC</b>	
<ul style="list-style-type: none"> <li>• Number range</li> <li>• Size, max.</li> </ul>	<p>0 ... 65 535</p> <p>1 Mbyte</p>
<b>OB</b>	
<ul style="list-style-type: none"> <li>• Size, max.</li> <li>• Number of free cycle OBs</li> <li>• Number of time alarm OBs</li> <li>• Number of delay alarm OBs</li> <li>• Number of cyclic interrupt OBs</li> <li>• Number of process alarm OBs</li> <li>• Number of DPV1 alarm OBs</li> <li>• Number of isochronous mode OBs</li> <li>• Number of technology synchronous alarm OBs</li> <li>• Number of startup OBs</li> <li>• Number of asynchronous error OBs</li> <li>• Number of synchronous error OBs</li> <li>• Number of diagnostic alarm OBs</li> </ul>	<p>1 Mbyte</p> <p>100</p> <p>20</p> <p>20</p> <p>20; with minimum OB 3x cycle of 100 μs</p> <p>50</p> <p>3</p> <p>3</p> <p>2</p> <p>100</p> <p>4</p> <p>2</p> <p>1</p>
<b>Nesting depth</b>	
<ul style="list-style-type: none"> <li>• per priority class</li> </ul>	24
<b>Counters, timers and their retentivity</b>	
<b>S7 counter</b>	
<ul style="list-style-type: none"> <li>• Number</li> </ul>	2 048
<b>Retentivity</b>	
– adjustable	Yes
<b>IEC counter</b>	
<ul style="list-style-type: none"> <li>• Number</li> </ul>	Any (only limited by the main memory)
<b>Retentivity</b>	
– adjustable	Yes
<b>S7 times</b>	
<ul style="list-style-type: none"> <li>• Number</li> </ul>	2 048
<b>Retentivity</b>	
– adjustable	Yes
<b>IEC timer</b>	
<ul style="list-style-type: none"> <li>• Number</li> </ul>	Any (only limited by the main memory)
<b>Retentivity</b>	
– adjustable	Yes

<b>Article number</b>	<b>6ES7518-4AX00-1AB0</b>
<b>Data areas and their retentivity</b>	
Retentive data area (incl. timers, counters, flags), max.	768 kbyte; In total; available retentive memory for bit memories, timers, counters, DBs, and technology data (axes): 700 KB
Extended retentive data area (incl. timers, counters, flags), max.	20 Mbyte; When using PS 6 0W 24/48/60 V DC HF
<b>Flag</b>	
<ul style="list-style-type: none"> <li>• Size, max.</li> </ul>	16 kbyte
<ul style="list-style-type: none"> <li>• Number of clock memories</li> </ul>	8; 8 clock memory bit, grouped into one clock memory byte
<b>Data blocks</b>	
<ul style="list-style-type: none"> <li>• Retentivity adjustable</li> </ul>	Yes
<ul style="list-style-type: none"> <li>• Retentivity preset</li> </ul>	No
<b>Local data</b>	
<ul style="list-style-type: none"> <li>• per priority class, max.</li> </ul>	64 kbyte; max. 16 KB per block
<b>Address area</b>	
Number of IO modules	16 384; max. number of modules / submodules
<b>I/O address area</b>	
<ul style="list-style-type: none"> <li>• Inputs</li> </ul>	32 kbyte; All inputs are in the process image
<ul style="list-style-type: none"> <li>• Outputs</li> </ul>	32 kbyte; All outputs are in the process image
<b>per integrated IO subsystem</b>	
<ul style="list-style-type: none"> <li>– Inputs (volume)</li> </ul>	32 kbyte; max. 32 KB via X1; max. 8 KB via X2 or X4
<ul style="list-style-type: none"> <li>– Outputs (volume)</li> </ul>	32 kbyte; max. 32 KB via X1; max. 8 KB via X2 or X4
<b>per CM/CP</b>	
<ul style="list-style-type: none"> <li>– Inputs (volume)</li> </ul>	8 kbyte
<ul style="list-style-type: none"> <li>– Outputs (volume)</li> </ul>	8 kbyte
<b>Subprocess images</b>	
<ul style="list-style-type: none"> <li>• Number of subprocess images, max.</li> </ul>	32
<b>Hardware configuration</b>	
Number of distributed IO systems	64; A distributed I/O system is characterized not only by the integration of distributed I/O via PROFINET or PROFIBUS communication modules, but also by the connection of I/O via AS-i master modules or links (e.g. IE/PB-Link)
<b>Number of DP masters</b>	
<ul style="list-style-type: none"> <li>• integrated</li> </ul>	1
<ul style="list-style-type: none"> <li>• Via CM</li> </ul>	8; A maximum of 8 CMs/CPs (PROFIBUS, PROFINET, Ethernet) can be inserted in total
<b>Number of IO Controllers</b>	
<ul style="list-style-type: none"> <li>• integrated</li> </ul>	2
<ul style="list-style-type: none"> <li>• Via CM</li> </ul>	8; A maximum of 8 CMs/CPs (PROFIBUS, PROFINET, Ethernet) can be inserted in total

<b>Article number</b>	<b>6ES7518-4AX00-1AB0</b>
<b>Rack</b>	
<ul style="list-style-type: none"> <li>• Modules per rack, max.</li> <li>• Number of lines, max.</li> </ul>	<p>32; CPU + 31 modules</p> <p>1</p>
<b>PtP CM</b>	
<ul style="list-style-type: none"> <li>• Number of PtP CMs</li> </ul>	the number of connectable PtP CMs is only limited by the number of available slots
<b>Time of day</b>	
<b>Clock</b>	
<ul style="list-style-type: none"> <li>• Type</li> <li>• Backup time</li> <li>• Deviation per day, max.</li> </ul>	<p>Hardware clock</p> <p>6 wk; At 40 °C ambient temperature, typically</p> <p>10 s; Typ.: 2 s</p>
<b>Operating hours counter</b>	
<ul style="list-style-type: none"> <li>• Number</li> </ul>	16
<b>Clock synchronization</b>	
<ul style="list-style-type: none"> <li>• supported</li> <li>• to DP, master</li> <li>• to DP, slave</li> <li>• in AS, master</li> <li>• in AS, slave</li> <li>• on Ethernet via NTP</li> </ul>	<p>Yes</p> <p>Yes</p> <p>Yes</p> <p>Yes</p> <p>Yes</p> <p>Yes</p>
<b>Interfaces</b>	
Number of PROFINET interfaces	3
Number of PROFIBUS interfaces	1
<b>1. Interface</b>	
<b>Interface types</b>	
<ul style="list-style-type: none"> <li>• RJ 45 (Ethernet)</li> <li>• Number of ports</li> <li>• integrated switch</li> </ul>	<p>Yes; X1</p> <p>2</p> <p>Yes</p>
<b>Protocols</b>	
<ul style="list-style-type: none"> <li>• IP protocol</li> <li>• PROFINET IO Controller</li> <li>• PROFINET IO Device</li> <li>• SIMATIC communication</li> <li>• Open IE communication</li> <li>• Web server</li> <li>• Media redundancy</li> </ul>	<p>Yes; IPv4</p> <p>Yes</p> <p>Yes</p> <p>Yes</p> <p>Yes; Optionally also encrypted</p> <p>Yes</p> <p>Yes</p>

Article number	6ES7518-4AX00-1AB0
<b>PROFINET IO Controller</b>	
<b>Services</b>	
– Isochronous mode	Yes
– Direct data exchange	Yes; Requirement: IRT and isochronous mode (MRPD optional)
– IRT	Yes
– PROFlenergy	Yes; per user program
– Prioritized startup	Yes; Max. 32 PROFINET devices
– Number of connectable IO Devices, max.	512; In total, up to 1 000 distributed I/O devices can be connected via AS-i, PROFIBUS or PROFINET
– Of which IO devices with IRT, max.	64
– Number of connectable IO Devices for RT, max.	512
– of which in line, max.	512
– Number of IO Devices that can be simultaneously activated/deactivated, max.	8; in total across all interfaces
– Number of IO Devices per tool, max.	8
– Updating times	The minimum value of the update time also depends on communication share set for PROFINET IO, on the number of IO devices, and on the quantity of configured user data
– PROFINET Security Class	1
<b>Update time for IRT</b>	
– for send cycle of 125 µs	125 µs
– for send cycle of 187.5 µs	187.5 µs
– for send cycle of 250 µs	250 µs to 4 ms
– for send cycle of 500 µs	500 µs to 8 ms
– for send cycle of 1 ms	1 ms to 16 ms
– for send cycle of 2 ms	2 ms to 32 ms
– for send cycle of 4 ms	4 ms to 64 ms
– With IRT and parameterization of "odd" send cycles	Update time = set "odd" send clock (any multiple of 125 µs: 375 µs, 625 µs ... 3 875 µs)
<b>Update time for RT</b>	
– for send cycle of 250 µs	250 µs to 128 ms
– for send cycle of 500 µs	500 µs to 256 ms
– for send cycle of 1 ms	1 ms to 512 ms
– for send cycle of 2 ms	2 ms to 512 ms
– for send cycle of 4 ms	4 ms to 512 ms

Article number	6ES7518-4AX00-1AB0
<b>PROFINET IO Device</b>	
<b>Services</b>	
– Isochronous mode	No
– IRT	Yes; Minimum send cycle of 250 μs
– PROFINergy	Yes; per user program
– Shared device	Yes
– Number of IO Controllers with shared device, max.	4
– activation/deactivation of I-devices	Yes; per user program
– Asset management record	Yes; per user program
– PROFINET Security Class	SNMP Configuration and DCP Read Only
<b>2. Interface</b>	
<b>Interface types</b>	
• RJ 45 (Ethernet)	Yes; X2
• Number of ports	1
• integrated switch	No
<b>Protocols</b>	
• IP protocol	Yes; IPv4
• PROFINET IO Controller	Yes
• PROFINET IO Device	Yes
• SIMATIC communication	Yes
• Open IE communication	Yes; Optionally also encrypted
• Web server	Yes
• Media redundancy	No

Article number	6ES7518-4AX00-1AB0
<b>PROFINET IO Controller</b>	
<b>Services</b>	
– Isochronous mode	No
– Direct data exchange	No
– IRT	No
– PROFlenergy	Yes; per user program
– Prioritized startup	No
– Number of connectable IO Devices, max.	128; In total, up to 1 000 distributed I/O devices can be connected via AS-i, PROFIBUS or PROFINET
– Number of connectable IO Devices for RT, max.	128
– of which in line, max.	128
– Number of IO Devices that can be simultaneously activated/deactivated, max.	8; in total across all interfaces
– Number of IO Devices per tool, max.	8
– Updating times	The minimum value of the update time also depends on communication share set for PROFINET IO, on the number of IO devices, and on the quantity of configured user data
– PROFINET Security Class	1
<b>Update time for RT</b>	
– for send cycle of 1 ms	1 ms to 512 ms
<b>PROFINET IO Device</b>	
<b>Services</b>	
– Isochronous mode	No
– IRT	No
– PROFlenergy	Yes; per user program
– Prioritized startup	No
– Shared device	Yes
– Number of IO Controllers with shared device, max.	4
– activation/deactivation of I-devices	Yes; per user program
– Asset management record	Yes; per user program
– PROFINET Security Class	SNMP Configuration and DCP Read Only
<b>3. Interface</b>	
<b>Interface types</b>	
• RJ 45 (Ethernet)	Yes; X3
• Number of ports	1; C/C++ Runtime can also be reached via this port
• integrated switch	No

<b>Article number</b>	<b>6ES7518-4AX00-1AB0</b>
<b>Protocols</b>	
<ul style="list-style-type: none"> <li>• IP protocol</li> <li>• PROFINET IO Controller</li> <li>• PROFINET IO Device</li> <li>• SIMATIC communication</li> <li>• Open IE communication</li> <li>• Web server</li> </ul>	<p>Yes; IPv4</p> <p>No</p> <p>No</p> <p>Yes</p> <p>Yes; Optionally also encrypted</p> <p>Yes</p>
<b>4. Interface</b>	
<b>Interface types</b>	
<ul style="list-style-type: none"> <li>• RS 485</li> <li>• Number of ports</li> </ul>	<p>Yes; X4</p> <p>1</p>
<b>Protocols</b>	
<ul style="list-style-type: none"> <li>• PROFIBUS DP master</li> <li>• PROFIBUS DP slave</li> <li>• SIMATIC communication</li> </ul>	<p>Yes</p> <p>No</p> <p>Yes</p>
<b>PROFIBUS DP master</b>	
<ul style="list-style-type: none"> <li>• Number of connections, max.</li> <li>• Number of DP slaves, max.</li> </ul>	<p>48; for the integrated PROFIBUS DP interface</p> <p>125; In total, up to 1 000 distributed I/O devices can be connected via AS-i, PROFIBUS or PROFINET</p>
<b>Services</b>	
<ul style="list-style-type: none"> <li>– Equidistance</li> <li>– Isochronous mode</li> <li>– Activation/deactivation of DP slaves</li> </ul>	<p>Yes</p> <p>Yes</p> <p>Yes</p>
<b>Interface types</b>	
<b>RJ 45 (Ethernet)</b>	
<ul style="list-style-type: none"> <li>• 100 Mbps</li> <li>• 1000 Mbps</li> <li>• Autonegotiation</li> <li>• Autocrossing</li> <li>• Industrial Ethernet status LED</li> </ul>	<p>Yes</p> <p>Yes; Only possible at the X3 interface of the CPU 1518</p> <p>Yes</p> <p>Yes</p> <p>Yes</p>
<b>RS 485</b>	
<ul style="list-style-type: none"> <li>• Transmission rate, max.</li> </ul>	<p>12 Mbit/s</p>
<b>Protocols</b>	
PROFIsafe	No



Article number	6ES7518-4AX00-1AB0
<b>Number of connections</b> <ul style="list-style-type: none"> <li>• Number of connections, max.</li> <li>• Number of connections reserved for ES/HMI/web</li> <li>• Number of connections via integrated interfaces</li> <li>• Number of S7 routing paths</li> </ul>	384; via integrated interfaces of the CPU and connected CPs / CMs 10 320 64; in total, only 16 S7-Routing connections are supported via PROFIBUS
<b>Redundancy mode</b> <ul style="list-style-type: none"> <li>• H-Sync forwarding</li> </ul>	Yes
<b>Media redundancy</b> <ul style="list-style-type: none"> <li>– Media redundancy</li> <li>– MRP</li> <li>– MRP interconnection, supported</li> <li>– MRPD</li> <li>– Switchover time on line break, typ.</li> <li>– Number of stations in the ring, max.</li> </ul>	only via 1st interface (X1) Yes; MRP Automanager according to IEC 62439-2 Edition 2.0, MRP Manager; MRP Client Yes; as MRP ring node according to IEC 62439-2 Edition 3.0 Yes; Requirement: IRT 200 ms; For MRP, bumpless for MRPD 50
<b>SIMATIC communication</b> <ul style="list-style-type: none"> <li>• PG/OP communication</li> <li>• S7 routing</li> <li>• Data record routing</li> <li>• S7 communication, as server</li> <li>• S7 communication, as client</li> <li>• User data per job, max.</li> </ul>	Yes; encryption with TLS V1.3 pre-selected Yes Yes Yes Yes See online help (S7 communication, user data size)
<b>Open IE communication</b> <ul style="list-style-type: none"> <li>• TCP/IP                             <ul style="list-style-type: none"> <li>– Data length, max.</li> <li>– several passive connections per port, supported</li> </ul> </li> <li>• ISO-on-TCP (RFC1006)                             <ul style="list-style-type: none"> <li>– Data length, max.</li> </ul> </li> <li>• UDP                             <ul style="list-style-type: none"> <li>– Data length, max.</li> <li>– UDP multicast</li> </ul> </li> </ul>	Yes 64 kbyte Yes Yes 64 kbyte Yes 2 kbyte; 1 472 bytes for UDP broadcast Yes; 128 multicast circuits (of which max. 5 via X1)

Article number	6ES7518-4AX00-1AB0
<ul style="list-style-type: none"> <li>• DHCP</li> <li>• DNS</li> <li>• SNMP</li> <li>• DCP</li> <li>• LLDP</li> <li>• Encryption</li> </ul>	<p>Yes</p> <p>Yes</p> <p>Yes</p> <p>Yes</p> <p>Yes</p> <p>Yes; Optional</p>
<b>Web server</b> <ul style="list-style-type: none"> <li>• HTTP</li> <li>• HTTPS</li> </ul>	<p>Yes; Standard and user pages</p> <p>Yes; Standard and user pages</p>
<b>OPC UA</b> <ul style="list-style-type: none"> <li>• Runtime license required</li> <li>• OPC UA Client <ul style="list-style-type: none"> <li>– Application authentication</li> <li>– Security policies</li> <li>– User authentication</li> <li>– Number of connections, max.</li> <li>– Number of nodes of the client interfaces, recommended max.</li> <li>– Number of elements for one call of OPC-UA-NodeGetHandleList/OPC-UA-ReadList/OPC-UA-WriteList, max.</li> <li>– Number of elements for one call of OPC-UA-NameSpaceGetIndexList, max.</li> <li>– Number of elements for one call of OPC-UA-MethodGetHandleList, max.</li> <li>– Number of simultaneous calls of the client instructions for session management, per connection, max.</li> <li>– Number of simultaneous calls of the client instructions for data access, per connection, max.</li> <li>– Number of registerable nodes, max.</li> <li>– Number of registerable method calls of OPC-UA-MethodCall, max.</li> <li>– Number of inputs/outputs when calling OPC-UA-MethodCall, max.</li> </ul> </li> </ul>	<p>Yes; "Large" license required</p> <p>Yes; Data Access (registered Read/Write), Method Call</p> <p>Yes</p> <p>Available security policies: None, Basic128Rsa15, Basic256Rsa15, Basic256Sha256</p> <p>"anonymous" or by user name &amp; password</p> <p>40</p> <p>5 000</p> <p>300</p> <p>20</p> <p>100</p> <p>1</p> <p>5</p> <p>5 000</p> <p>100</p> <p>20</p>

Article number	6ES7518-4AX00-1AB0
<ul style="list-style-type: none"> <li>• OPC UA Server                             <ul style="list-style-type: none"> <li>– Application authentication</li> <li>– Security policies</li> <li>– User authentication</li> <li>– GDS support (certificate management)</li> <li>– Number of sessions, max.</li> <li>– Number of accessible variables, max.</li> <li>– Number of registerable nodes, max.</li> <li>– Number of subscriptions per session, max.</li> <li>– Sampling interval, min.</li> <li>– Publishing interval, min.</li> <li>– Number of server methods, max.</li> <li>– Number of inputs/outputs per server method, max.</li> <li>– Number of monitored items, recommended max.</li> <li>– Number of server interfaces, max.</li> <li>– Number of nodes for user-defined server interfaces, max.</li> </ul> </li> <li>• Alarms and Conditions                             <ul style="list-style-type: none"> <li>– Number of program alarms</li> <li>– Number of alarms for system diagnostics</li> </ul> </li> </ul>	Yes; Data Access (Read, Write, Subscribe), Method Call, Alarms & Condition (A&C), Custom Address Space  Yes  available security policies: None, Basic128Rsa15, Basic256Rsa15, Basic256Sha256, Aes128Sha256RsaOaep, Aes256Sha256RsaPss "anonymous" or by user name & password  Yes  64  200 000  50 000  50  10 ms  10 ms  100  20  24 000; for 1 s sampling interval and 1 s send interval  10 of each "Server interfaces" / "Companion specification" type and 20 of the type "Reference namespace"  50 000  Yes  400  200
<b>Further protocols</b>	
<ul style="list-style-type: none"> <li>• MODBUS</li> </ul>	Yes; MODBUS TCP
<b>Isochronous mode</b>	
Equidistance	Yes

Article number	6ES7518-4AX00-1AB0
<b>S7 message functions</b>	
Number of login stations for message functions, max.	64
number of subscriptions, max.	750
number of tags/attributes for subscriptions, max.	50 000
Program alarms	Yes
Number of configurable program messages, max.	10 000; Program messages are generated by the "Program_Alarm" block, ProDiag or GRAPH
Number of loadable program messages in RUN, max.	10 000
Number of simultaneously active program alarms	
• Number of program alarms	4 000
• Number of alarms for system diagnostics	1 000
• Number of alarms for motion technology objects	480
<b>Test commissioning functions</b>	
Joint commission (Team Engineering)	Yes; Parallel online access possible for up to 10 engineering systems
Status block	Yes; Up to 16 simultaneously (in total across all ES clients)
Single step	No
Number of breakpoints	20
Profiling	No
<b>Status/control</b>	
• Status/control variable	Yes
• Variables	Inputs/outputs, memory bits, DBs, distributed I/Os, timers, counters
• Number of variables, max.	
– of which status variables, max.	200; per job
– of which control variables, max.	200; per job
<b>Forcing</b>	
• Forcing	Yes
• Forcing, variables	Peripheral inputs/outputs
• Number of variables, max.	200
<b>Diagnostic buffer</b>	
• present	Yes
• Number of entries, max.	3 200
– of which powerfail-proof	1 000
<b>Traces</b>	
• Number of configurable Traces	8
• Memory size per trace, max.	512 kbyte

Article number	6ES7518-4AX00-1AB0
<b>Interrupts/diagnostics/status information</b>	
<b>Diagnostics indication LED</b>	
• RUN/STOP LED	Yes
• ERROR LED	Yes
• MAINT LED	Yes
• Connection display LINK TX/RX	Yes
<b>Supported technology objects</b>	
Motion Control	Yes; Note: The number of technology objects affects the cycle time of the PLC program; selection guide via the TIA Selection Tool
• Number of available Motion Control resources for technology objects	15 360
• Required Motion Control resources	
– per speed-controlled axis	40
– per positioning axis	80
– per synchronous axis	160
– per external encoder	80
– per output cam	20
– per cam track	160
– per probe	40
• Positioning axis	
– Number of positioning axes at motion control cycle of 4 ms (typical value)	140
– Number of positioning axes at motion control cycle of 8 ms (typical value)	192
Controller	
• PID_Compact	Yes; Universal PID controller with integrated optimization
• PID_3Step	Yes; PID controller with integrated optimization for valves
• PID-Temp	Yes; PID controller with integrated optimization for temperature
Counting and measuring	
• High-speed counter	Yes
<b>Standards, approvals, certificates</b>	
Suitable for safety functions	No

<b>Article number</b>	<b>6ES7518-4AX00-1AB0</b>
<b>Ambient conditions</b>	
<b>Ambient temperature during operation</b>	
<ul style="list-style-type: none"> <li>horizontal installation, min.</li> </ul>	0 °C
<ul style="list-style-type: none"> <li>horizontal installation, max.</li> </ul>	60 °C; Display: 50 °C, at an operating temperature of typically 50 °C, the display is switched off
<ul style="list-style-type: none"> <li>vertical installation, min.</li> </ul>	0 °C
<ul style="list-style-type: none"> <li>vertical installation, max.</li> </ul>	40 °C; Display: 40 °C, at an operating temperature of typically 40 °C, the display is switched off
<b>Ambient temperature during storage/transportation</b>	
<ul style="list-style-type: none"> <li>min.</li> </ul>	-40 °C
<ul style="list-style-type: none"> <li>max.</li> </ul>	70 °C
<b>Altitude during operation relating to sea level</b>	
<ul style="list-style-type: none"> <li>Installation altitude above sea level, max.</li> </ul>	5 000 m; Restrictions for installation altitudes > 2 000 m, see manual
<b>configuration / header</b>	
<b>configuration / programming / header</b>	
<b>Programming language</b>	
<ul style="list-style-type: none"> <li>– LAD</li> </ul>	Yes
<ul style="list-style-type: none"> <li>– FBD</li> </ul>	Yes
<ul style="list-style-type: none"> <li>– STL</li> </ul>	Yes
<ul style="list-style-type: none"> <li>– SCL</li> </ul>	Yes
<ul style="list-style-type: none"> <li>– CFC</li> </ul>	Yes
<ul style="list-style-type: none"> <li>– GRAPH</li> </ul>	Yes
<b>Know-how protection</b>	
<ul style="list-style-type: none"> <li>User program protection/password protection</li> </ul>	Yes
<ul style="list-style-type: none"> <li>Copy protection</li> </ul>	Yes
<ul style="list-style-type: none"> <li>Block protection</li> </ul>	Yes
<b>Access protection</b>	
<ul style="list-style-type: none"> <li>protection of confidential configuration data</li> </ul>	Yes
<ul style="list-style-type: none"> <li>Password for display</li> </ul>	Yes
<ul style="list-style-type: none"> <li>Protection level: Write protection</li> </ul>	Yes
<ul style="list-style-type: none"> <li>Protection level: Read/write protection</li> </ul>	Yes
<ul style="list-style-type: none"> <li>Protection level: Write protection for Failsafe</li> </ul>	No
<ul style="list-style-type: none"> <li>Protection level: Complete protection</li> </ul>	Yes
<ul style="list-style-type: none"> <li>User administration</li> </ul>	Yes

<b>Article number</b>	<b>6ES7518-4AX00-1AB0</b>
<b>programming / cycle time monitoring / header</b>	
<ul style="list-style-type: none"> <li>• lower limit</li> <li>• upper limit</li> </ul>	<p>adjustable minimum cycle time</p> <p>adjustable maximum cycle time</p>
<b>Open Development interfaces</b>	
<ul style="list-style-type: none"> <li>• Size of ODK SO file, max.</li> </ul>	9.8 Mbyte
<b>Dimensions</b>	
Width	175 mm
Height	147 mm
Depth	129 mm
<b>Weights</b>	
Weight, approx.	2 093 g

### General technical specifications

You can find information on the general technical specifications, such as standards and approvals, electromagnetic compatibility, protection class, etc., in the S7-1500, ET 200MP (<https://support.industry.siemens.com/cs/ww/en/view/59191792>) system manual.

# A

## Dimensional drawing

This section contains the dimensional drawing of the module on the mounting rail, as well as a dimensional drawing with the front panel open. Keep to the dimensions when installing in cabinets, control rooms, etc.

### Dimension drawings of the CPU 1518-4 PN/DP MFP

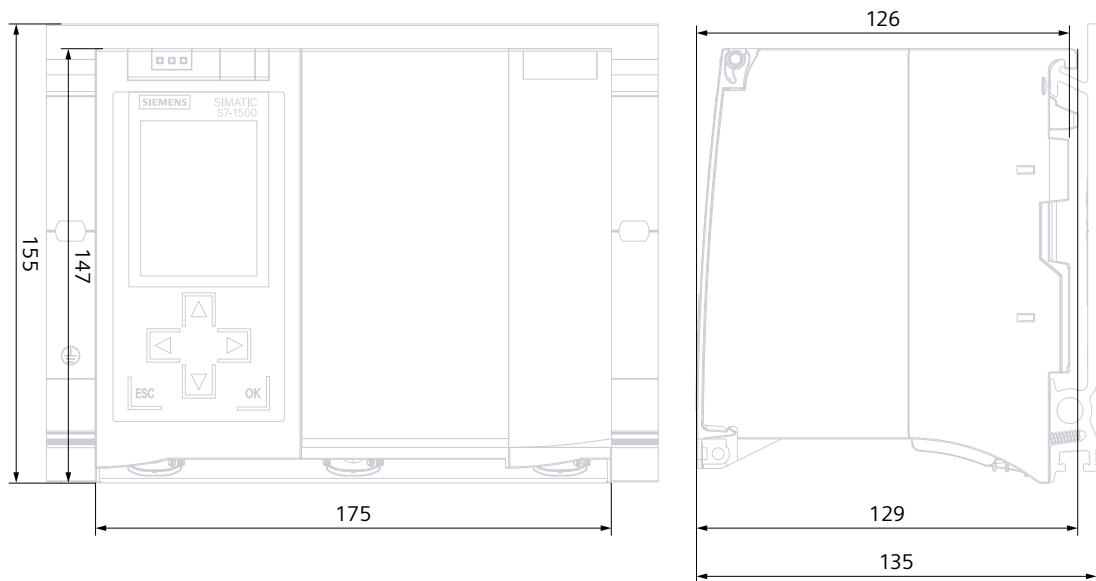

Figure A-1 Dimension drawing of the CPU 1518-4 PN/DP MFP, front and side view

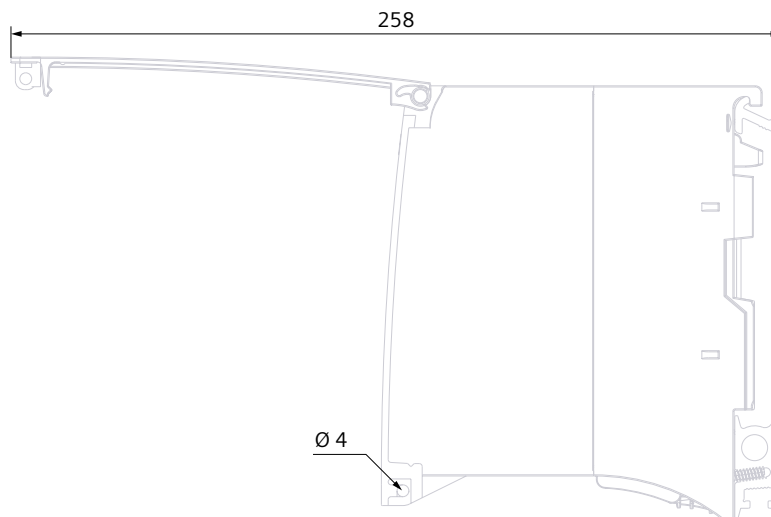

Figure A-2 Dimension drawing CPU 1518-4 PN/DP MFP, side view with open front panel