

The right choice for the ultimate yield!

LS ELECTRIC strives to maximize your profits in gratitude for choosing us as your partner.

# AC Variable Speed Drive

LSLV-iV5 series

User's Manual

2.2-37kW [200V] 2.2-500kW [400V]



## Safety Instructions

- Read this manual carefully before installing, wiring, operating, servicing or inspecting this equipment.
- Keep this manual within easy reach for quick reference.

**LS** ELECTRIC

## **This User's Manual is aimed at.....**

Describing specification, installation, operation, function, and maintenance of SV-iV5 series inverter provided for the users who are familiar with and having basic experience in the inverter.

Be sure to understand function, performance, installation, and operation of the product by reading through this User's Manual completely prior to your use of SV-iV5 series inverter that you have purchased. In addition, you are required to have this User's Manual properly delivered to the end-user and maintenance manager.

### **■ Option Module Guide**



The following Option Module Guides will be provided when you purchase the applicable Option Module. In addition, if you access our homepage <http://www.lselectric.co.kr/> [Customer Support] - [Download Data Room], you can download it in PDF file.

- IV5 EL (Elevator) I/O Option Module Guide (Korean)
- IV5 SYNC Option Module Guide (Korean)
- IV5 SIN/COS Encoder Card Option Module Guide (Korean)
- IP5A/IV5 RS-485 & Modbus-RTU Option Module Guide (Korean)
- IS5/IP5A/IV5 Profibus-DP Card Option Module Guide (Korean)
- IS5/IP5A/IV5 DeviceNet Card Option Module Guide (Korean)
- IP5A/IV5 CC-Link Card Option Module Guide (Korean)

## Safety Instructions

To prevent injury and property damage, follow these instructions. Incorrect operation due to ignoring instructions will cause harm or damage.



The seriousness of which is indicated by the following symbols.

Symbol		Meaning
	Warning	This symbol indicates the possibility of death or serious injury.
	Caution	This symbol indicates the possibility of injury or damage to property.

### Remark

- Even if the instructions are indicated as 'Caution', it can cause a serious result according to the kind of operation and the environment.

The meaning of each symbol in this manual and on your equipment is as follows.

Symbol	Meaning
	This is the safety alert symbol. Read and follow instructions carefully to avoid dangerous situation.
	This symbol alerts the user to the presence of "dangerous voltage" inside the product that might cause harm or electric shock.

After reading this manual, keep it in the place that the user always can contact easily.

This manual should be given to the person who actually uses the products and is responsible for their maintenance.

### WARNING

- Do not remove the cover while power is applied or the unit is in operation.  
Otherwise, electric shock could occur.

### WARNING

- **Do not run the inverter with the front cover removed.**  
Otherwise, you may get an electric shock due to high voltage terminals or charged capacitor exposure.
- **Do not remove the cover except for periodic inspections or wiring, even if the input power is not applied.**  
Otherwise, you may access the charged circuits and get an electric shock.
- **Wiring and periodic inspections should be performed at least 10 minutes after disconnecting the input power and after checking the DC link voltage is discharged with a meter (below DC 30V).**  
Otherwise, you may get an electric shock.
- **Operate the switches with dry hands.**  
Otherwise, you may get an electric shock.
- **Do not use the cable when its insulating tube is damaged.**  
Otherwise, you may get an electric shock.
- **Do not subject the cables to scratches, excessive stress, heavy loads or pinching.**  
Otherwise, you may get an electric shock.

### CAUTION

- **Install the inverter on a non-flammable surface. Do not place flammable material nearby.**  
Otherwise, fire could occur.
- **Disconnect immediately the input power if the inverter gets damaged.**  
Otherwise, it could result in a secondary accident and fire.
- **After the input power is applied or removed, the inverter will remain hot for a couple of minutes.**  
Otherwise, you may get bodily injuries such as skin-burn or damage.
- **Do not apply power to a damaged inverter or to an inverter with parts missing even if the installation is complete.**  
Otherwise, electric shock could occur.
- **Do not allow lint, paper, wood chips, dust, metallic chips or other foreign matter into the drive.**  
Otherwise, fire or accident could occur.

## Caution for Use

### ■ Transportation and Installation

- Be sure to carry inverter in a proper way suitable for its weight, or it may result in damage to inverter.
- Be sure to use heat-treated wooden crate when you adopt wooden packaging for the product.
- Do not pile up inverters above allowable limit.
- Be sure to install the inverter as directed in this instruction manual.
- Do not turn off the power supply to the damaged inverter.
- Do not open the front cover while carrying the inverter.
- Do not place the heavy material on the inverter.
- The direction of installation should be observed properly as criterions specified in this manual show.
- Make sure that you should not put screw, metal material, water, oil and the inflammable something else.
- Keep in mind that inverter is very vulnerable to drop from the mid air and strong shock.
- Don't let the inverter exposed to rain, snow, fog, dust, etc.
- Do not cover, nor block, the ventilating system having cooling fan. It may cause the inverter overheated.
- Be sure to check the power is off when installing the inverter.
- To prevent the risk of fire or electric shock, keep the connected wire in a sound condition. Use the wire that meets the standard in a recommended length.
- Be sure to ground the inverter. (Under 10Ω to 200V class, Under 100Ω to 400V class)
- Be certain to use the inverter under the following conditions.

Environment	Description
Ambient Temperature	- 10 ~ 40 °C (Non-frozen) (Less than 80% load is recommended at 50°C.)
Ambient Humidity	Below 90% RH (Dewdrop should not be formed)
Storage Temperature	-20 ~ 65 °C
Ambient Condition	Free of corrosive gas, inflammable gas, oil sludge and dust, etc
Altitude/Vibration	Below 1000m above sea level, Below 5.9m/sec <sup>2</sup> (=0.6g)
Ambient Air Pressure	70 ~ 106 kPa

### ■ Wiring

#### ⚠ Caution

- **A professional installer should have done the wiring and checking.**
- Do wiring after installing the inverter body.
- Do not connect phase-leading capacitors, surge filter, radio noise filter to the output of inverter.
- Output terminals (terminals named U, V, W respectively) should be connected in a proper phase sequence.
- Make sure that there is not any short circuit terminal, wrong wiring. It may cause spurious operation or failure.
- Refrain from using a cable other than the cable shielded when you connect control circuit wiring.
- Adopt the shielded wire only when wiring the control circuit. It may cause the failure of inverter in its operation. Use the twisted pair shield wire for the ground terminal of the inverter.

#### ⚠ Warning

- **To prevent an electric shock, be sure to check if MCCB and MC are switched OFF before wiring**  
Otherwise, it may cause an electric shock.



## ■ Adjustment before starting trial operation

- Do not supply the excessive range of voltage displayed in the user manual to the each terminal. It may cause damage to the inverter.
- Current hunting can be occurred in the low speed territory during testing. It occurs where the capacity is above 110kW with no-load and the axis is not connected.  
The current hunting has a gap according to the motor characteristic. It will be disappeared when the load is connected and it is not the indication of abnormal condition.  
If the hunting is occurred seriously, please stop the testing and operates with the load.
- Be sure to check relevant parameters for the application before starting trial operation.

## ■ How to Use

- Be sure not to approach the machine when retry function is selected. The machine may start working suddenly.
- Stop key on the keypad should be set to be in use. For safety, additional emergency stop circuit should be required.
- Inverter restarts if alarm condition is cleared while FX/RX signal is on. Therefore, be sure to operate the alarm reset switch after checking if FX / RX signal is off.
- Never modify the inverter for inappropriate use.
- When a magnetic contactor is installed on the power source, do not frequently start or stop using this magnetic contactor. It may cause the failure of inverter.
- Noise filter should be used for the minimization of troubles by electromagnetic noise. Electronic equipments close to the inverter should be protected against the damage caused by troubles.
- Be sure to install the AC reactor at the input of inverter in case of input voltage unbalance. Otherwise, generator or phase-leading capacitors may be destroyed by the harmonic current from inverter.
- If 400V class motor is used with the inverter, insulation-enforced motor should be used or countermeasures against the suppression of micro-surge voltage generated by the inverter should be carried out.

Otherwise, micro-surge voltage is generated across input terminal for the motor and this voltage lowers allowable insulation break-down voltage and then, may cause the destruction of the motor.

- Be sure to set the parameters once more, in case of initialization of parameters, all values of parameters is set to values of factory setting.
- High speed operation can be set easily, therefore be sure to check the performance of motor or machine before changing parameter value.
- DC braking function cannot produce a zero-servo torque. If required, additional equipment should be installed.
- When inverter trip or emergency stop (BX) occurs without keypad connected, LED on the control board will blink by the interval of 0.5 sec. But LED will blink by 1 sec when keypad is connected. This function displays which trip will be occurred according to the connection of keypad.
- Do not change wiring, nor disconnect connector or option card during the operation of inverter.
- Do not disconnect the motor wiring while the voltage of inverter is output. Mishandling may cause damage to the inverter.
- Be sure to handle the inverter and option care in the order recommended in the Electro Static Discharge (ESD) Countermeasure. Mishandling may lead to damage to the circuit on the PCB caused by ESD.

### ■ Countermeasure against malfunction troubles

- If inverter is damaged and then gets into uncontrollable situation, the machine may lead to the dangerous situation, therefore to avoid this situation, be sure to install the additional equipments such as brake.

### ■ Maintenance, inspection and parts replacement

- Do not perform the megger (insulation resistance check) test on the control board.
- Please refer to intervals for parts replacement on Chapter 8.

### ■ Disposal

- Handle the inverter as an industrial waste when disposing of it.



- Our inverter contains the raw material of value that can be recycled from the aspect of energy and resource preservation. All the package materials and metal parts are recyclable. Plastics are also recyclable, but may be burnt under the controllable environment depending on the local regulation.

### ■ General Instruction

- The drawing in this user manual is represented the details of the inner inverter, so, the drawing is described without cover part and circuit breaker. But, cover and circuit breaker should be mounted before the operation following to the instruction of user manual.
- Turn off the power of inverter when the inverter is not used.

### ■ Cleaning

- Be sure to operate the inverter under a clean condition.
- When cleaning the inverter, be sure to check the inverter is off. Start cleaning it with all the plugs connected with the inverter socket removed.
- Never clean the inverter using wet cloth or water. Wipe the stained area softly using the cloth completely wet with a neutral detergent or ethanol.
- Never use the solution such as acetone, benzene, toluene, alcohol, etc. They may cause the coating on the surface of the inverter to peel off. In addition, do not clean LCD display, etc. using detergent or alcohol.

### ■ Storage

Be sure to keep the inverter under the following conditions if you don't use it for a long period of time.

- Make sure that you satisfy the recommended storage environment. (See page v.)
- If the storage period exceeds 3 months, be sure to keep it at the ambient temperature of  $-10 \sim +30^{\circ} \text{C}$  to prevent 『Deterioration by Temperature』 of electrolytic condenser.

## Safety Instructions

- Be sure to keep it in a proper package to prevent moisture, etc. Put the desiccant (Silica Gel), etc., in the package so that the relative humidity in the package can be maintained at 70% or less.
- When it is exposed to moisture or dust (mounted on the 『System』 or 『Control Panel』, etc. installed at the construction site), remove it and then keep it under the environmental condition specified in the page v.

### Caution

- **If the inverter has been left long with electric current not charged, the nature of electrolytic condenser can be deteriorated. So be sure to have it plugged in for 30 ~ 60 minutes once a year. Do not perform wiring and operation of the output side (secondary side).**

<b>Chapter 1</b>	<b>Introduction</b>	
	1.1 Key Features -----	1-1
	1.2 Inverter Nameplate and Model -----	1-2
<b>Chapter 2</b>	<b>Specification</b>	
	2.1 Standard Specification -----	2-1
	2.2 Common Specification -----	2-3
<b>Chapter 3</b>	<b>Installation and Wiring</b>	
	3.1. Caution on Installation -----	3-2
	3.2 Basic Wiring -----	3-4
	3.3 Power Circuit Terminal -----	3-11
	3.4 Control Board and Terminal -----	3-18
	3.5 Terminal of the Auxiliary Power Supply -----	3-27
<b>Chapter 4</b>	<b>Trial Operation</b>	
	4.1 Keypad Operation -----	4-1
	4.2 Keypad LCD Display-----	4-2
	4.3 Setting of Parameter Values -----	4-3
	4.4 Data Group -----	4-4
	4.5 Auto-Tuning -----	4-6
	4.6 Pulse Encoder Check -----	4-10
	4.7 Operation by Keypad -----	4-11
	4.8 Operation by Control Terminal -----	4-12
<b>Chapter 5</b>	<b>Function Code Table</b>	
	5.1 Display Group (DIS_[][]) -----	5-1
	5.2 Digital DIO Group (DIO_[][]) -----	5-3
	5.3 Parameter Group (PAR_[][]) -----	5-7
	5.4 Function Group (FUN_[][]) -----	5-9
	5.5 Control Group (CON_[][]) -----	5-13
	5.6 User Group (USR_[][]) -----	5-15
	5.7 Second motor Group (2nd_[][]) -----	5-16
	5.8 Option Group (EXT_[][]) -----	5-17
	5.9 Analog AIO Group (AIO_[][]) -----	5-19

5.10 Sensorless control Group (SLS_[][]) -----	5-24
<b>Chapter 6 Inspection and Replacement</b>	
6.1 Precautions -----	6-1
6.2 Checking Points -----	6-1
6.3 Routine Checking -----	6-2
6.4 Regular Checking (1 year interval) -----	6-4
6.5 Meggar Test -----	6-6
6.6 Regular Checking (2 year interval) -----	6-7
6.7 Replacement Interval and Maintenance of the Key Components -----	6-7
6.8 How to Check at Diode Module & IGBT Inspection -----	6-8
<b>Chapter 7 Troubleshooting and Maintenance</b>	
7.1 Fault Display -----	7-1
7.2 Monitoring Fault Condition -----	7-4
7.3 Fault Reset -----	7-4
7.4 Fault Remedy -----	7-4
<b>Chapter 8 Accessories</b>	
8.1 MCCB(LS), ELB(LS), Magnetic contactor(LS), Input/Output Wire Specifications -----	8-1
8.2 AC input fuse, AC reactor, DC reactor -----	8-2
8.3 The selection of Braking Resistor and the Unit -----	8-3
<b>Chapter 9 Dimensions</b> -----	9-1

## Chapter 1 - Introduction

This instruction manual is designed for **LS STARVERT-iV5 series Vector Control Inverters**, which have excellent characteristics in speed and torque control with pulse encoder mounted on the shaft of 3 phase induction motor, and covers installation, maintenance, wiring and operation for these inverters.

### 1.1 Key Features

- Current Controlled Vector Control Inverter with Speed Sensor using IGBT as Power Semiconductor Device.
- Tension/Torque Control and Wide Variety of Process Control
- Process PI Control, Draw Control, Droop Control, Synchronous Control, WEB Control etc.
- Auto-tuning of Motor Parameters for Precise Speed/Torque Control : Rotational/Standstill mode
- Encoder error (H/W and S/W) detection function
- Auxiliary battery function and Emergent operation by battery operation
- Various option for communication and application

#### Inverter Application

Application	Applicable Machine/System	Features
Process Control	<ul style="list-style-type: none"> <li>▪ Steel Strip</li> <li>▪ Paper Mill</li> <li>▪ Textile</li> <li>▪ Film</li> <li>▪ Coater</li> <li>▪ Printing Machine</li> </ul>	Tension Control Wide Range of Speed Control
Hoisting Control	<ul style="list-style-type: none"> <li>▪ Lifts (Elevators)</li> <li>▪ Parking</li> <li>▪ Stacker Crane</li> <li>▪ Crane</li> <li>▪ Hoist</li> </ul>	High Speed Operation High Starting Torque Positioning Wide Range of Speed Control
Machine Control	<ul style="list-style-type: none"> <li>▪ Machine Tool</li> <li>▪ Wire Drawing</li> <li>▪ Extruder</li> </ul>	High Speed Operation High Starting Torque Positioning
Others	<ul style="list-style-type: none"> <li>▪ Conveyor</li> <li>▪ Industrial Washing Machine</li> </ul>	High Speed Operation Positioning

## 1.2 Inverter Nameplate and Model

### 1.2.1 Inverter nameplate (Example)

<b>SV [ ] [ ] [ ] [ ] iV5-2DB</b>			← Inverter Model Name
INPUT	200 - 230 V [ ] [ ] [ ] A	3 Phase 50/60Hz	← Input Power Source Specifications
			← Rated Capacity
OUTPUT	0 - Input V [ ] [ ] [ ] A	3 Phase 0 - 3600rpm	← Output Power Source Specifications
			← Running Freq. / Rated Output Current
			← Output Capacity
	Ser. No [ ] [ ] [ ] [ ] [ ] [ ] [ ] [ ] [ ] [ ] [ ] [ ] [ ] [ ]		← Serial Code
	Inspected by [ ] . [ ] . [ ] [ ] [ ] [ ] [ ] [ ]		

### 1.2.2 Inverter model name

	SV	[ ] [ ] [ ] [ ]	iV5 – 2	DB	(MD)	(380V)	(ENC)
<ul style="list-style-type: none"> <li>● LS STARVERT Series</li> <li>● Max. Applicable Motor 022 : 2.2kW ~ 5000 : 500kW</li> <li>● iV5 Series</li> <li>● Input Voltage <ul style="list-style-type: none"> <li>2 : 200V Class (200 ~ 230V) ,</li> <li>4 : 400V Class (380 ~ 480V)</li> </ul> </li> <li>● Built-in DB Circuit <ul style="list-style-type: none"> <li>DB : Built-in DB Circuit (DB Resistors Integrated)</li> <li>DC : DC Power Input</li> <li>Blank : No Built-in DB Circuit (Use external DB Unit)</li> </ul> </li> <li>● MD : Mold Type (2.2~22kW) (Electrical specification of MD type is based on specifications of 5.5~2.2kW except for the specification of exterior and its size.)</li> <li>● Input Voltage <ul style="list-style-type: none"> <li>(380V) : 380V Input Voltage – 30~220kW(400V)</li> <li>Blank : Below 22kW (200V/400V) and 280~500kW(400V)</li> </ul> </li> <li>● ENCODER TYPE <ul style="list-style-type: none"> <li>- Blank : 5V Line Drive, 15V Open Collector</li> <li>- 24V ENC : 24V Line Drive/Open Collector</li> <li>-</li> <li>-</li> </ul> </li> </ul>							

## Chapter 2 - Specification

### 2.1 Standard Specification

#### 2.1.1 200V Class (AC power input type)

SV[ ] [ ] [ ] iV5-2(DB)		022	037	055	075	110	150	185	220	300	370
Max. applicable motor output <sup>Note1)</sup>	[HP]	3	5	7.5	10	15	20	25	30	40	50
	[kW]	2.2	3.7	5.5	7.5	11	15	18.5	22	30	37
Output	Capacity [kVA] <sup>Note2)</sup>	4.5	6.1	9.1	12.2	17.5	22.5	28.2	33.1	46	55
	Rated current [A]	12	16	24	32	46	59	74	88	122	146
	Speed	0 ~ 3600 (rpm)									
	Voltage	0 ~ 200V (230V <sup>Note3)</sup> )									
Input	Voltage	3 $\phi$ 200 ~ 230V (-10% ~ +10%)									
	Frequency	50 ~ 60Hz ( $\pm$ 5%)									
Inverter weight [kg(lbs)]		6 (13)	6 (13)	14 (30)	14 (30)	27.5 (60)	27.5 (60)	28 (61)	28 (61)	42 (93)	42 (93)

#### 2.1.2 400V Class (AC power input type)

SV[ ] [ ] [ ] iV5-4(DB)		022	037	055	075	110	150	185	220	300	370	450
Max. applicable motor output <sup>Note1)</sup>	[HP]	3	5	7.5	10	15	20	25	30	40	50	60
	[kW]	2.2	3.7	5.5	7.5	11	15	18.5	22	30	37	45
Output	Capacity [kVA] <sup>Note2)</sup>	4.5	6.1	9.1	12.2	18.3	22.9	29.7	34.3	46	57	70
	Rated current [A]	6	8	12	16	24	30	39	45	61	75	91
	Speed	0 ~ 3600 (rpm)										
	Voltage	0 ~ 380V (480 <sup>Note3)</sup> )										
Inverter weight [kg(lbs)]		6 (13)	6 (13)	14 (30)	14 (30)	27 (59)	28 (61)	28 (61)	28 (61)	42 (93)	42 (93)	63 (139)

SV[ ] [ ] [ ] iV5-4		550	750	900	1100	1320	1600	2200	2800	3150	3750	5000
Max. applicable motor output <sup>Note1)</sup>	[HP]	75	100	120	150	175	215	300	373	420	500	666
	[kW]	55	75	90	110	132	160	220	280	315	375	500
Output	Capacity [kVA] <sup>Note2)</sup>	85	116	140	170	200	250	329	416	468	557	732
	Rated Current [A]	110	152	183	223	264	325	432	546	614	731	960
	Speed	0 ~ 3600 (rpm)										
	Voltage	0 ~ 380V (480V <sup>Note3)</sup> )										

## 2. Specification

SV□□□□iV5-4		550	750	900	1100	1320	1600	2200	2800	3150	3750	5000
Inverter weight [kg(lbs)]		63 (139)	68 (150)	98 (216)	98 (216)	122 (269)	122 (269)	175 (386)	243 (536)	380 (838)	380 (838)	476 (1050)
Input	Voltage	3φ 380 ~ 480V (-10% ~ +10%) <sup>Note4)</sup>										
	Frequency	50 ~ 60 Hz (±5%)										

※ The electrical specifications of the MD type (2.2~22kW Class) are the same as the above. (In case of 2.2 and 3.7 kW products, refer to the weight in above table.)

SV□□□□iV5-2/4DB(MD)		055	075	110	150	185	220
Inverter weight [kg(lbs)]		7.7 (16.9)	7.7 (16.9)	13.7 (30.2)	13.7 (30.2)	20.3 (44.7)	20.3 (44.7)

### 2.1.3 400V Class (DC power input type)

SV□□□□iV5-4(DC)		055	075	110	150	185	220	300	370	450	550
Max. applicable motor output <sup>Note1)</sup>	[HP]	7.5	10	15	20	25	30	40	50	60	75
	[kW]	5.5	7.5	11	15	18.5	22	30	37	45	55
Output	Capacity [kVA] <sup>Note2)</sup>	9.1	12.2	18.3	22.9	29.7	34.3	46	57	70	85
	Rated current [A]	12	16	24	30	39	45	61	75	91	110
	Speed	0 ~ 3600 (rpm)									
	Voltage	0 ~ 380V (480V <sup>Note3)</sup> )									
Input rated voltage		DC 540 ~ 680V (+10%) <sup>Note5)</sup>									
Inverter weight [kg(lbs)]		12 (26)	12 (26)	24 (53)	24.5 (54)	25 (55)	25 (55)	38.5 (84)	38.5 (84)	50 (110)	50 (110)

SV□□□□iV5-4(DC)		750	900	1100	1320	1600	2200	2800	3150	3750	5000
Max. applicable motor output (Note1)	[HP]	100	120	150	175	215	300	373	420	500	666
	[kW]	75	90	110	132	160	220	280	315	375	500
Output	Capacity [kVA] <sup>Note2)</sup>	116	140	170	200	250	329	416	468	557	732
	Rated current [A]	152	183	223	264	325	432	546	614	731	960
	Speed	0 ~ 3600 (rpm)									
	Voltage	0 ~ 380V (480V <sup>Note3)</sup> )									
Input rated voltage		DC 540 ~ 680V (+10%) <sup>Note5)</sup>									
Inverter weight [kg(lbs)]		55 (121)	79 (174)	79 (174)	98.5 (217)	98.5 (217)	154.5 (340)	206 (454)	343 (756)	343 (756)	466 (1028)



**Note)**

1. It represents the output capacity of maximum applicable motor in case 4-pole motor is used. (220V is based on 220V and 400V is based on 440V.)
2. Rated capacity ( $=\sqrt{3} \cdot V \cdot I$ ) is calculated based on 220V for 200V class, 440V for 400V class.
3. Maximum output voltage cannot be generated above specified input voltage.
4. Derate the rated current by 10% when the input voltage is in the range above 480V.
5. Rated current is derated by 10% above 680VDC of input voltage.

**2.2 Common Specification**

Items		Detailed Specification
Inverter type		Voltage source inverter using IGBT
Control	Control method	<ul style="list-style-type: none"> <li>● Vector control inverter with speed sensor attached, Sensorless Vector control inverter</li> </ul>
	Speed control accuracy	<ul style="list-style-type: none"> <li>● Analog setting: <math>\pm 0.1\%</math> (<math>25 \pm 10^\circ\text{C}</math>) of max. Speed (1,800 rpm)</li> <li>● Digital setting: <math>\pm 0.1\%</math> (0 ~ <math>40^\circ\text{C}</math>) of max. Speed (1,800 rpm)</li> </ul>
	Speed setting resolution	<ul style="list-style-type: none"> <li>● Analog setting: <math>\pm 0.1\%</math> of maximum Speed</li> <li>● Digital setting: 0.1 rpm</li> </ul>
	Cut-off frequency of ASR	50Hz
	Torque control accuracy	3%
	Overload Capacity	CT: 150%/1Min
	Accel/Decel	Time setting
Combination		4 combinations of acceleration/deceleration Time
Pattern		Linear, S-Curve
Braking	Braking method	Dynamic braking using external resistors
	Braking torque	150%
	Braking resistor	External braking resistor should be attached.
Input	Speed settings	<ul style="list-style-type: none"> <li>● Digital setting via keypad</li> <li>● Multi-step speed setting by input terminal selection</li> <li>● Analog input settings</li> <li>● Remote setting by option card</li> </ul>

## 2. Specification

Items		Detailed Specification
	Analog input	<ul style="list-style-type: none"> <li>● 3 channels (AI1, AI2, AI3*, (AI4,AI5: Extended I/O))</li> <li>● -10→10V, 10→10V, 0→10V, 10→0V,0→20mA, 20→0mA, Motor NTC (*Only AI3(AI5:Extended I/O) selectable)</li> <li>● Selectable among 17 different user-defined functions</li> <li>● AI3(AI5): Motor NTC only available with Higen motors</li> </ul>
	Contact input	<ul style="list-style-type: none"> <li>● FX, RX, BX, RST, P1 ~ P7</li> <li>● Selectable among 46 different user-defined input functions</li> </ul>
Output	Analog output	<ul style="list-style-type: none"> <li>● 2 channels (AO1, AO2)</li> <li>● -10V → 10V, 10 → -10V, 0 → 10V, 10 → 0V output</li> <li>● Selectable among 39 different user-defined functions</li> </ul>
	Contact output	<ul style="list-style-type: none"> <li>● 2 channels (1A-1B, 2A-2B)</li> <li>● Fault alarm relay: 1 channel (30A-30C, 30B-30C)</li> </ul>
	Open Collector	1 Channel (OC1/EG)
	Protection	Overcurrent, Overvoltage, Low voltage, Inverter overheat, Inverter thermal sensor malfunction, Motor overheat, Motor thermal sensor malfunction, Overspeed, Instantaneous IGBT gate block (BX), Fuse blown open, External Trip, Pulse encoder malfunction, Electronic thermal function, Inverter overload, Ground fault current, IGBT short, Communication error, Input/Output phase open protection
Environment	Installation condition	Indoor, Free of Corrosive gas and Direct sunlight (Pollution Degree 2)
	Ambient temperature	-10 ~ 40°C (Non-frozen condition)
	Humidity	Below RH 90% (Dewdrop should not be formed)
	Cooling method	Forced ventilation by cooling fan
	IP Type	IP00: 2.2 ~ 22 kW (MD), 30 ~ 500kW IP20: 5.5 ~ 2.2 kW (Press)
	Altitude, Vibration	Below 1000m above sea level, Below 5.9m/s <sup>2</sup> (=0.6G)

## Chapter 3 – Installation and Wiring

**This chapter describes general items for the installation and wiring of an inverter and includes instruction for wiring to power terminal and control one and caution in case of wiring, and also explains the function of each terminal for both power and control.**

Be sure to check mechanical and electrical installation environment before you start the inverter. Read through the checking list below. Be sure to read through the Caution for Safety on this User's Manual prior to the operation of inverter.

### Checking List

- Mechanical Installation Checking List
  - Be sure to check the surrounding environment is allowed for operation. (Read through the 'Caution on Installation')
  - Inverter is a heat-generating device. Be sure to sufficiently secure the surrounding space to prevent thermal saturation phenomenon.
  - Be sure to check air is circulated in a normal condition.
  - Be sure to check motor and drive system are ready to start.
  
- Electrical Installation Checking List
  - Make sure that the protective grounding is properly done.
  - Replace the condenser with new one if it lasted longer than two years.
  - Set the input voltage to the nominal input voltage of the inverter.
  - Check if the input voltage connected with R, S, T and then fasten them tightly using an accurate torque wrench.
  - Check if input power fuse and circuit breaker are properly installed.
  - Install the motor cable away from the other cable.
  - Check if the ext. input/output is properly connected.
  - Check if the input voltage is properly connected with the output terminal of inverter.

### 3.1 Caution on Installation

#### 3.1.1 Do not install the inverter in a location where excessive vibration is present.

Be cautious when installing on presses or moving equipment.

#### 3.1.2 Caution on ambient temperature

Ambient temperature greatly affects inverter lifetime, therefore be sure to keep the ambient temperature of installation location at  $-10$  to  $40^{\circ}\text{C}$ .

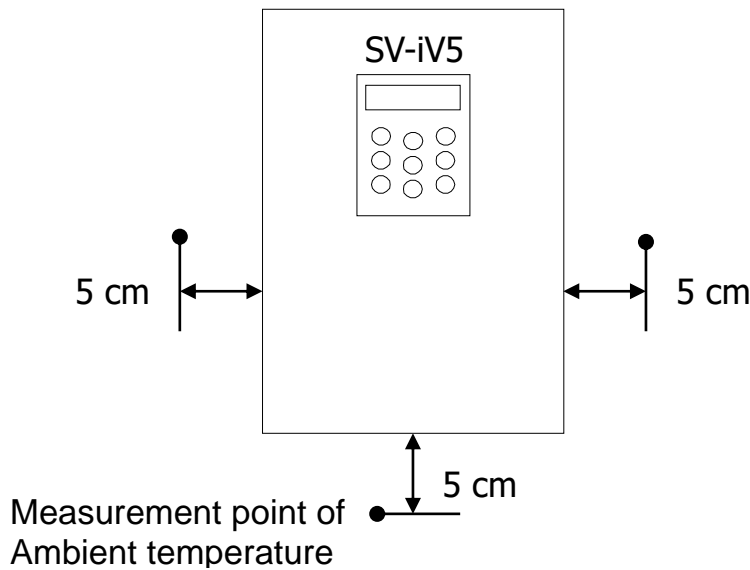

#### 3.1.3 Install the inverter on the unflammable material. The inverter operates at high-temperature.

#### 3.1.4 Avoid a humid and hot location.

#### 3.1.5 Install the inverter in a location free of oil mist and dust.

Totally enclosed panel can be used to protect the inverter against that materials. Cooling air must be clean, free from corrosive materials and electrically conductive dust.

### 3.1.6 Secure the installation space enough to protect the inverter against the overheating.

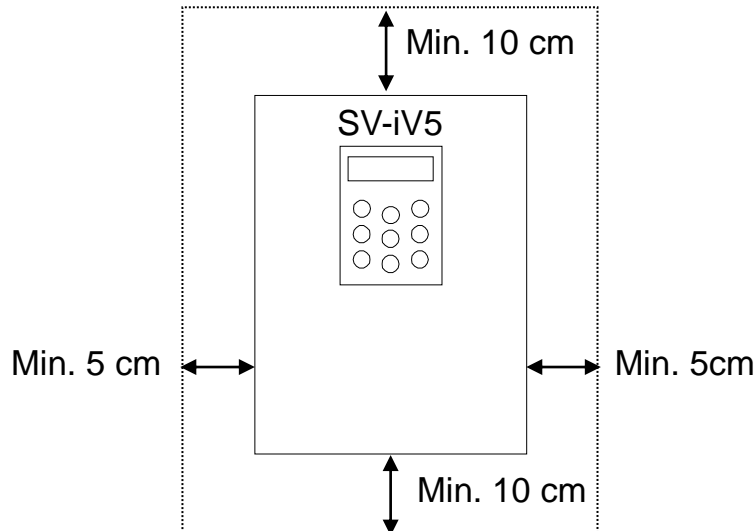

At least the room that 30 cm from upper and lower of inverter and 20 cm from left and right of inverter is required for installing more than 30 kW products.

### 3.1.7 Special care should be taken in case the inverter is to be installed in the panel.

In case more than 2 inverters are to be installed or ventilation fan is to be installed in the panel, make sure that inverter and ventilation fan is properly installed. If they are poorly installed, it causes the increase of an ambient temperature and less effective ventilation. Therefore, be sure to keep the ambient temperature of inverter below the allowable temperature.

### 3.1.8 Install the inverter tightly not to get loose using proper sized bolt or screw.

## 3.2 Basic Wiring

Do the wiring of inverter and then check the wiring of main circuit and control circuit before starting it. Read through the checking list as below.

### Checking List

Inverter, Peripherals, Option card

Is the inverter supplied in the form as ordered?

- Are the type and numbers of peripherals (Resistance, DC reactor, Noise filter, etc.) supplied as ordered?
- Is the type of option supplied as supplied?

Place of the inverter to be installed and how to install it

- Is the inverter installed on a right place in a right way?

Power voltage, Output voltage

- Is power voltage within the range of inverter input voltage specified?
- Does the rated output comply with the inverter output specification?
- Is the rating done properly?

Main Circuit Wiring

- Is the power input using the circuit breaker?
- Is the rating of the circuit breaker done properly?
- Is the power wiring input properly to the inverter input terminal? [If the input power is connected with the input terminal (U, V, W) it may cause damage to the inverter]
- Is the motor wiring connected with the inverter output terminal in a proper phase sequence? (Otherwise, the motor will be rotated adversely.)
- Is 600V vinyl insulation wire adopted for the power and motor wires?
- Is the main circuit wire in a proper size?
- Is the ground line installed in a proper way?
- Are the screws of the main circuit terminal and the ground terminal fastened tightly?
- In the event several motors are operated with one inverter, does each motor have a overload protecting circuit?
- In the event it adopts braking resistance or braking resistance unit, is an electronic contactor installed at the inverter power side so as to isolate the inverter from the power by protecting the resistance from overload?
- Isn't power condenser, surge killer, or radio noise filter connected with the output side?

#### Checking List

##### Control Circuit Wiring

- Is a twisted pair shielded wire adopted for the inverter control circuit wiring?
- Is the covered wire with shield connected with the ground terminal?
- In the event it is operated in 3-Wire sequence, is the control circuit wiring done after the parameter of multi-function contact input terminal is modified?
- Is the wiring of the optional devices done properly?
- Aren't there any wiring mis-connected?
- Are the inverter control circuit terminal screws fastened tightly?
- Aren't there any wire fragments or screw left?
- Doesn't the remaining wire connected with the terminal contact the terminals nearby?
- Is the control circuit wiring isolated from the main circuit wiring in the duct or control panel?
- Doesn't the length of wiring exceed 300m ? (In the case of the produce of 3.7kW or less, the entire length of wiring should be 100m or less)
- Doesn't the wiring of safety input exceed 30m?

### 3. Installation and Wiring

- AC Power Input Type**  
**SV022, 037, 055, 075, 110, 150, 185, 220iV5-2(DB)**  
**SV022, 037, 055, 075, 110, 150, 185, 220iV5-4(DB)**

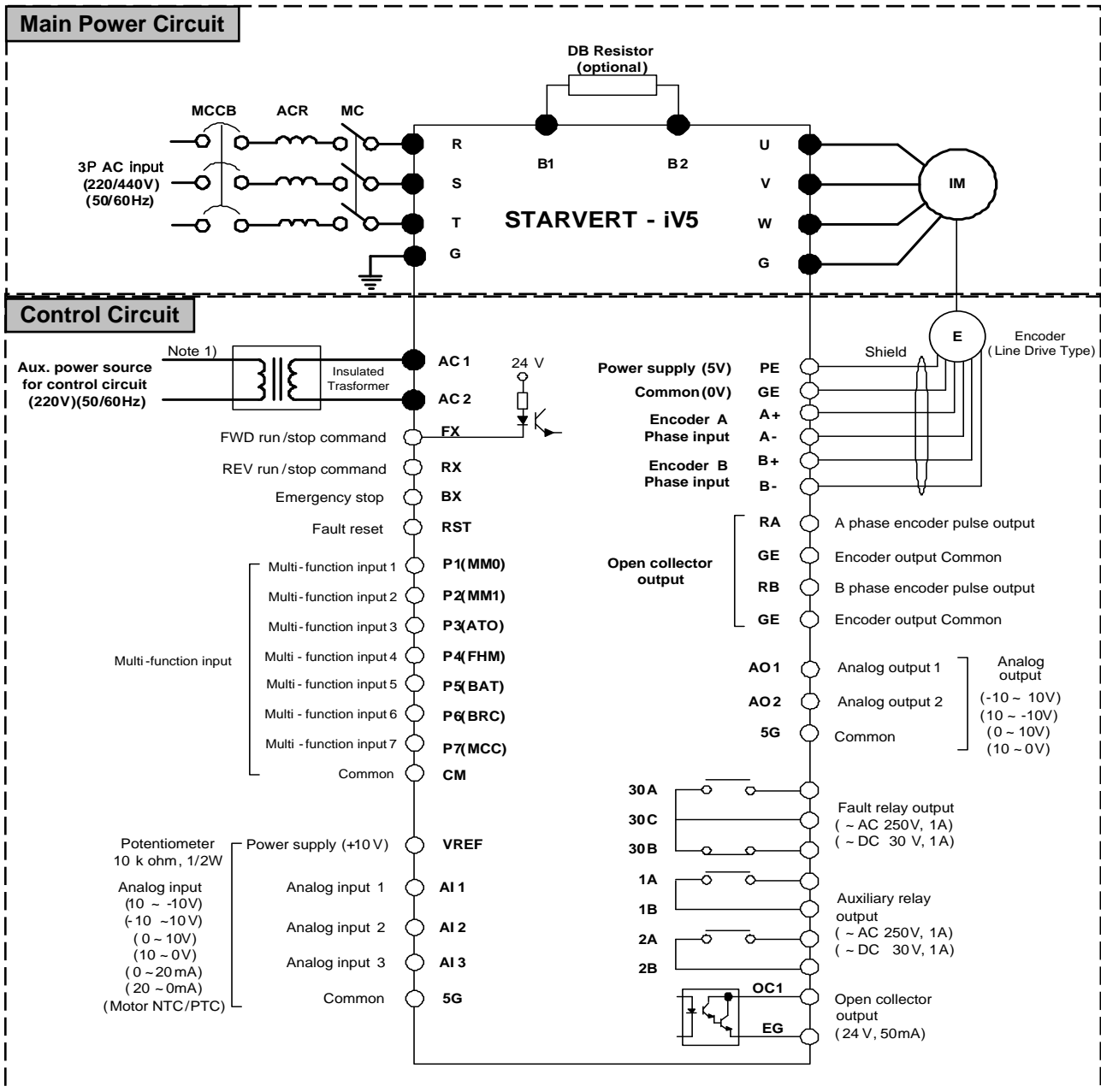

Note 1) It is used when inverter control circuit is energized from auxiliary power source (220 VAC) separated from main power supply. Use insulated transformer to separate from main power supply. (Transformer capacity: Above 100VA recommended) **Only 11~22kW-2(Press) and 5.5~22kW-4(Press/Mold) supported (Other products will be released later.)**



■ **AC Power Input Type**  
**SV300, 370iV5-2**

**SV300, 370, 450, 550, 750, 900, 1100, 1320, 1600, 2200, 2800, 3150, 3750iV5-4**

Note: AC Fans for 300~2200iV5-4 series should be changed the input power source of transformer 1<sup>st</sup> tap corresponding with that of inverter. (Factory default is 380VAC)

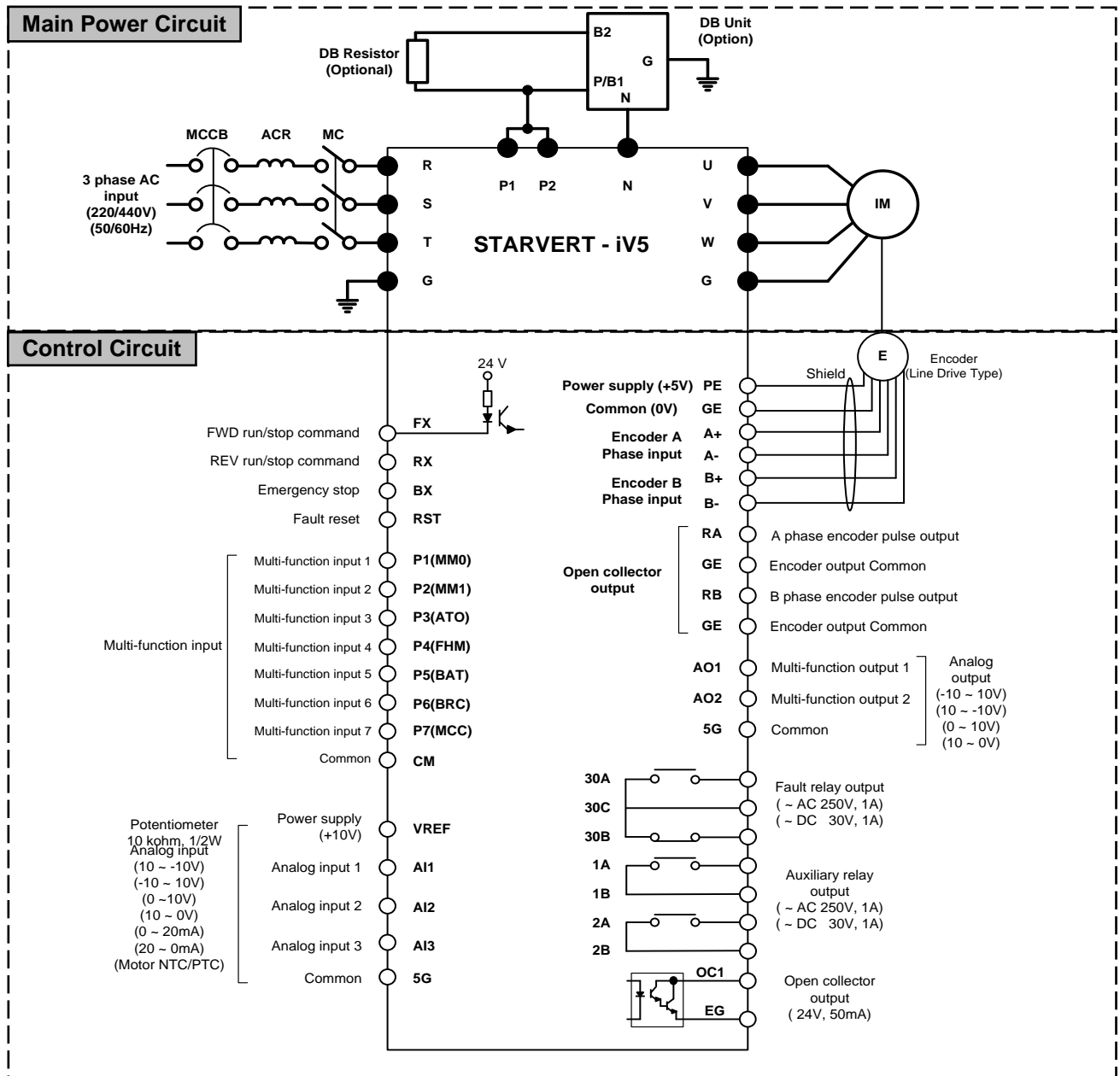

Note 1) It is used when inverter control circuit is energized from auxiliary power source (220 VAC) without main power supply. Use insulated transformer to separate from main power supply. (Transformer capacity: above 100VA recommended)

### 3. Installation and Wiring

#### ■ AC Power Input Type SV5000iV5-4

Note: AC220V (50/60 Hz) must be supplied to FAN1 and FAN2 because 500kW-4 type of inverter has an AC fan of 220V internally. If not use AC220V power, the inverter is not operated because of 'FAN PWR' until the trip is released after inputting of AC220V. The order of power supply is described as below.  
 (The order of power on: 220VAC for fan → Main power source of 3-phase AC input → Run)  
 (The order of power off: Stop → Main power source of 3-phase AC input → 220VAC for fan)

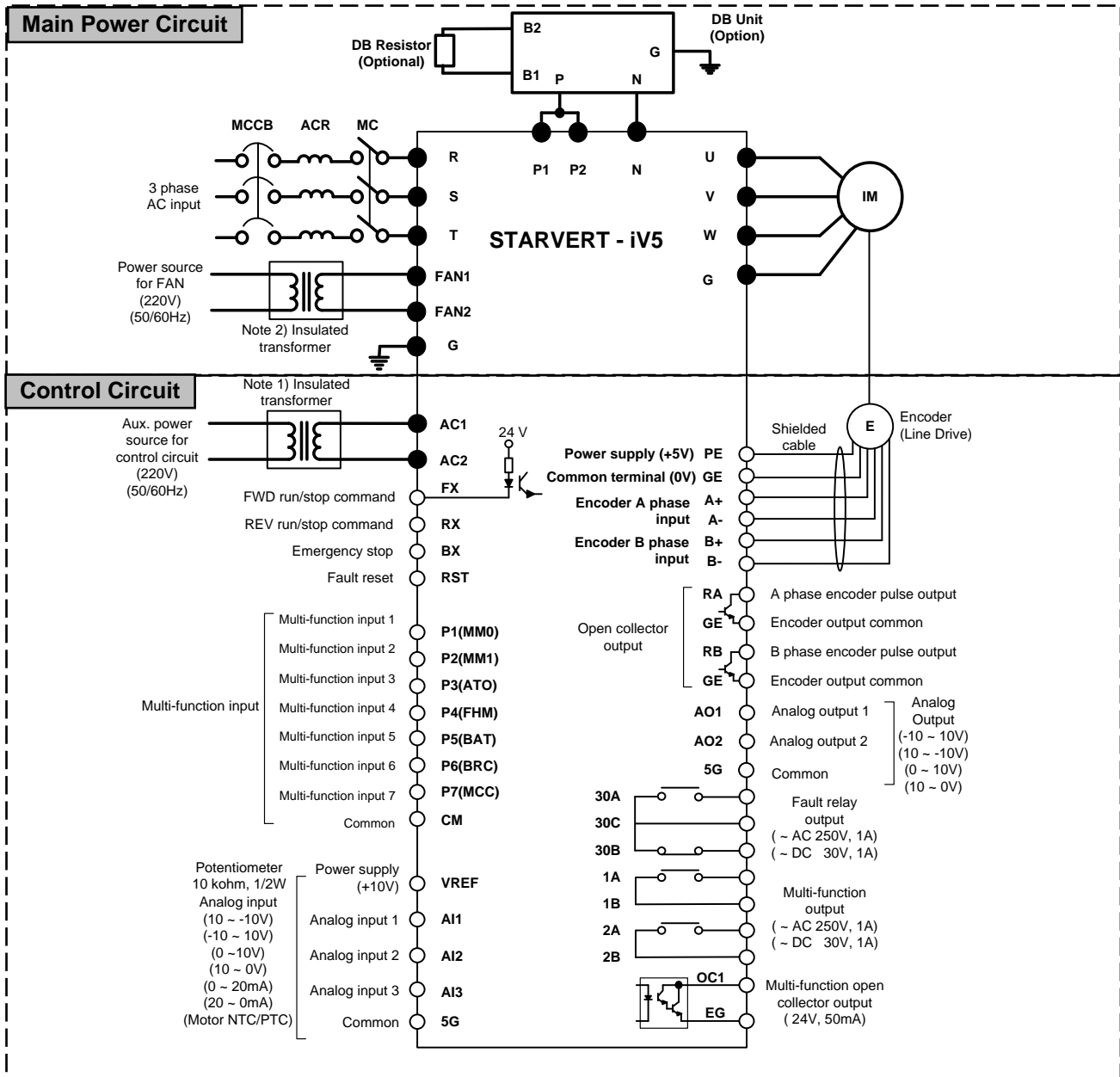

Note 1) It is used when inverter control circuit is energized from auxiliary power source (220 VAC) without main power supply. Use insulated transformer to separate from main power supply. (Transformer capacity: above 100VA recommended)

Note 2) The power of 220 VAC is must be supplied because it is for the operation of internal cooling fan. Use insulated transformer to separate from main power supply. (Transformer capacity: above 500VA recommended)

#### DC Power Input Type

SV055, 075, 110, 150, 185, 220, 2800, 3150, 3700iV5-4DC

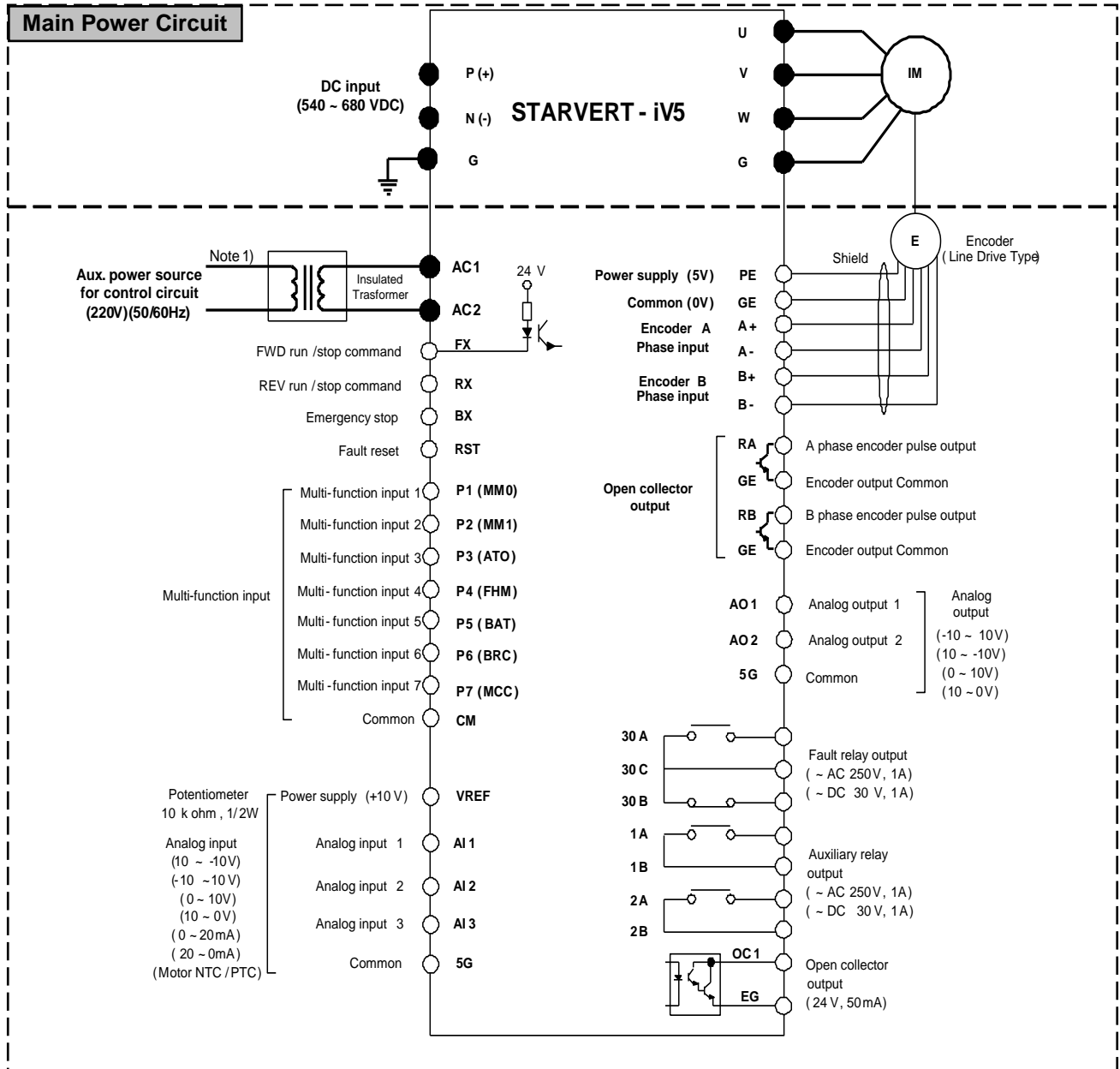

Note 1) It is used when inverter control circuit is energized from auxiliary power source (220 VAC) without main power supply. Use insulated transformer to separate from main power supply. (Transformer capacity: above 100VA recommended)

### 3. Installation and Wiring

#### DC Power Input Type

SV300, 370, 450, 550, 750, 900, 1100, 1320, 1600, 2200, 5000iV5-4DC

**Warning**) It must be energized AC220V (50/60Hz) to terminal of FAN1 and FAN2 because 30 ~ 500 kW-4DC series have a cooling fan for AC power drive and MC. If not, Trip (30~160kW: "FAN/MC PWR", 220kW: "FAN PWR") will be occurred. The inverter is not operated unless trip is released after AC220V inputs. The recommended order of power input and cutoff is as shown below.

(The order of power On: 220VAC → P(+)/N(-) → Run, The order of power Off: Stop → P(+)/N(-) → 220VAC)

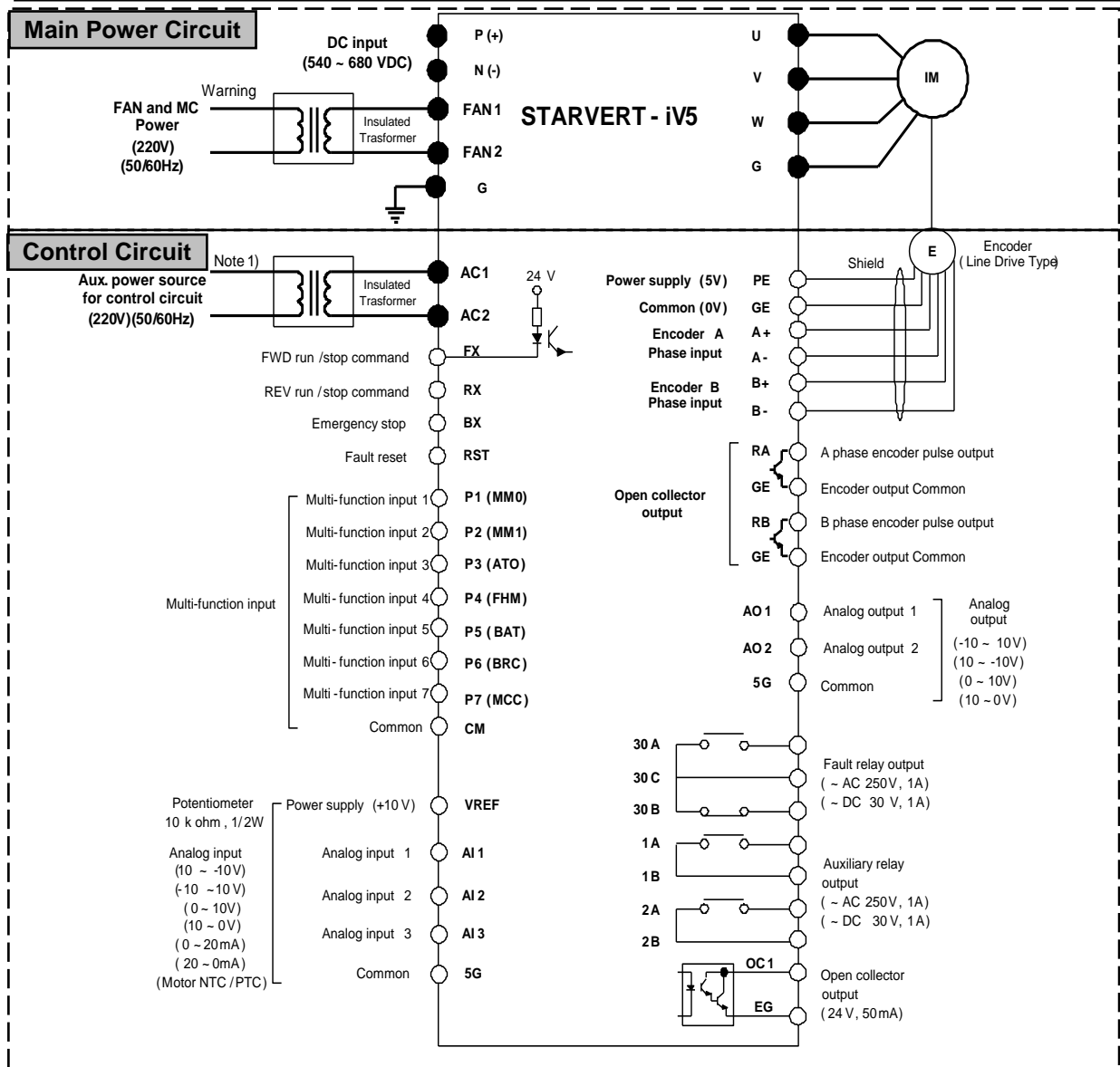

Note) ● : Main circuit ○ : Control circuit

Note 1) It is used when inverter control circuit is energized from auxiliary power source (220 VAC) without main power supply. Use insulated transformer to separate from main power supply. (Transformer capacity: above 100VA recommended)

Note 2) The power of 220VAC is must be supplied for the operation of internal cooling fan and/or Magnetic contactor. Use insulated transformer to separate from main power supply.

(30 ~ 160 kW: for the operation of FAN and MC, 220/500kW: for the operation of FAN)

(Transformer capacity: above 30~75kW(100VA), 90~160kW(150VA), 220/500kW(500VA) recommended )

### 3.3 Power Circuit Terminal

#### 3.3.1 Power circuit terminal arrangement

##### (1) AC power input type

 <b>CAUTION</b>
Be sure that “N” is not Neutral Line but DCN(-) and P is DCP(+).

- SV022, 037, 055, 075, 110, 150, 185, 220iV5-2(DB)  
SV022, 037, 055, 075, 110, 150, 185, 220iV5-4(DB)



- SV110, 150, 185, 220iV5-2(DB)(MD)  
SV110, 150, 185, 220iV5-4(DB)(MD)

\*(MD) : Mold Type

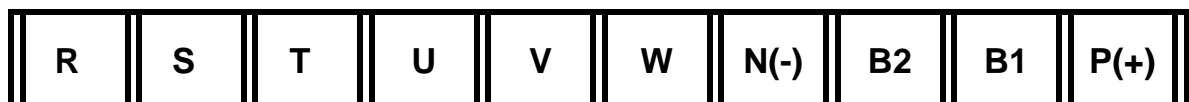

- SV300, 370iV5-2  
SV300, 370, 450, 550, 750iV5-4

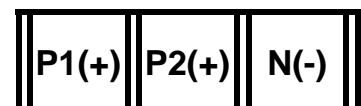

### 3. Installation and Wiring

- SV900, 1100, 1320, 1600, 2200iV5-4

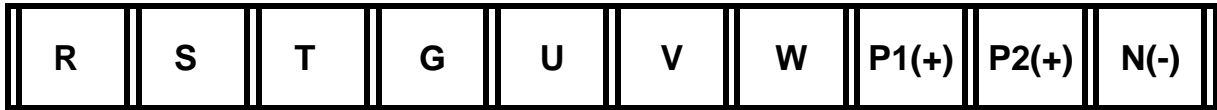

- SV2800, 3150, 3750, 5000 iV5-4

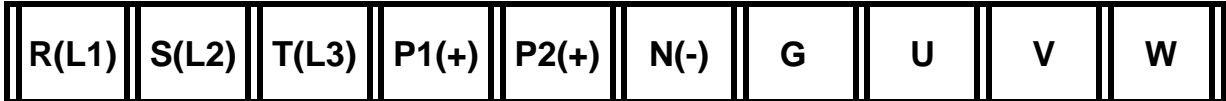

#### (2) DC power input type

- SV055, 075iV5-4DC



- SV110, 150, 185, 220iV5-4DC

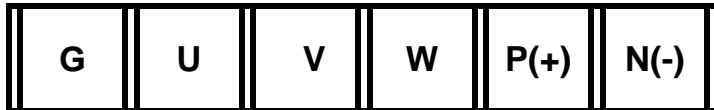

- SV300, 370,450,550,750,900,1100,1320,1600,2200iV5-4DC

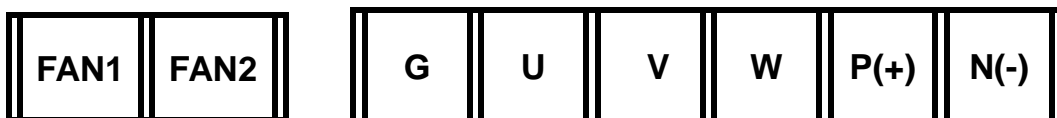

- SV2800, 3150, 3750, 5000iV5-4DC

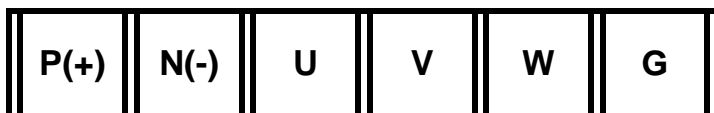

### 3.3.2 Power circuit terminal description

#### (1) AC power input type

Name	Function	Description
R, S, T	3 Phase input power supply	Connected to 3 phase input power supply
U, V, W	Inverter Output	Connected to 3 phase induction motor
G	Grounding	Used for inverter frame earth
B1, B2	Braking Resistor	Connected to braking resistor
P1(+), P2(+)	DC Reator and DB Unit	Used for DC Reactor, DB Unit and DC link common connection
P(+)	DC Link common	DC link common connection
N(-)	DB Unit	Used for DB Unit and DC link common connection

#### (2) DC power input type

Name	Function	Description
P(+), N(-)	DC input power	Connected to DC input power source Connected from DC power supply (PWM converter) within max. 30m
U, V, W	Inverter Output	Connected to 3-phase induction motor
G	Grounding	Used for inverter frame earth
FAN1, FAN2	Internal cooling fan and MC drive power source	Connected to single-phase 220V AC power source <sup>note1)</sup>

Note 1) In case of 500kW product, it is applied at AC input type.

### 3.3.3 Cautions to be required for wiring to power circuit terminal

- ① Connect terminals (R, S and T) to 3 phase input power supply after checking inverter nameplate attached on the inverter. Never connect terminals (U, V and W) to 3 phase input power supply. It results in lethal damage to the inverter.

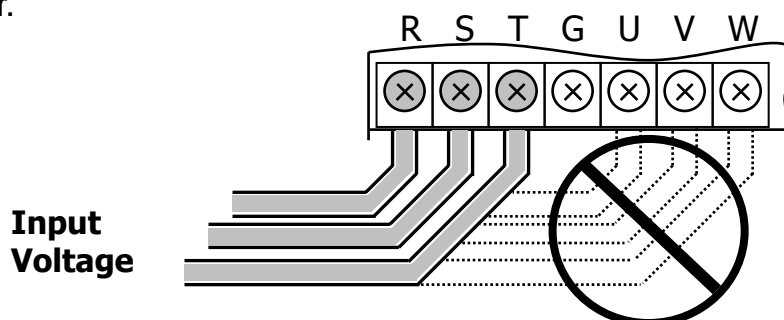

### 3. Installation and Wiring

- ② Never connect the phase advancing capacitor to the inverter output. If already installed, remove the phase advancing capacitor clearly.

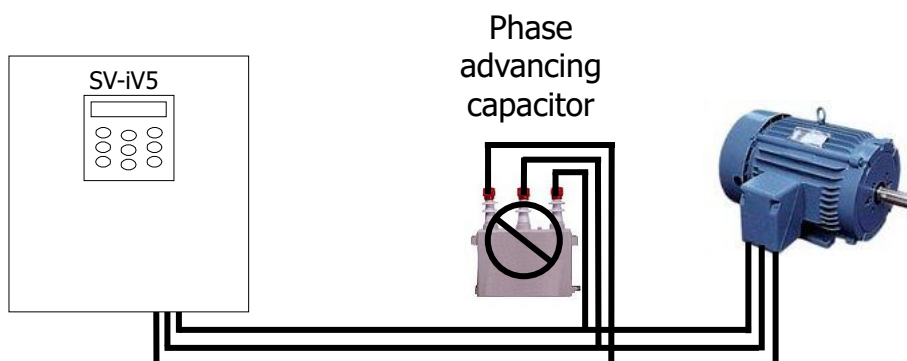

- ③ Cable between inverter output and motor should be less than 30m long. If cable gets long, surge voltage appears across motor terminals depending on the cable parameters. Especially, in 400V class motor case, insulation withstanding voltage may be decreased. Use an insulation-enforced motor when 400V class motor is used.

Distance between inverter and motor	Up to 50m	Up to 100m	Over 100m
Permitted Carrier Frequency	Below 10kHz	Below 5kHz	Below 2.5kHz

(In case of below 3.7 kW, use the cable of output within 100 m)

- ④ Crimp terminal with insulation cap should be used for the input power supply and the motor.
- ⑤ After finishing wiring, be certain to remove all the wire or cable scraps inside the inverter.
- ⑥ Use the shield cable or twist-paired wire for control circuit terminal. Do not put them into the same wiring duct for the power terminal.
- ⑦ When wiring is changed after operating the inverter, be sure to check LCD window on the keypad or charge lamp is turned off. Capacitors inside inverter are charged with high voltage and it may result in lethal injury.
- ⑧ Below 22kW inverter, B1 and B2 on the power terminal should not be connected to anything else other than DB resistors.



### 3.3.4 Main power circuit wire sizes and grounding wire size

#### ① Main Power Circuit Wire Sizes

If wiring for the main power terminal is not performed properly, it may cause severe damage to inverter or lethal injury to inverter operator.

**(Standards of IEC 60227-3 or UL508C)**

Inverter Capacity		Wire Size			
		mm <sup>2</sup>		AWG or kcmil	
		R, S, T	U, V, W	R, S, T	U, V, W
200V	2.2 kW	2.5	2.5	12	12
	3.7 kW	4	4	10	10
	5.5 kW	6	6	8	8
	7.5 kW	10	10	6	6
	11 kW	16	16	4	4
	15 kW	25	25	3	3
	18.5 kW	35	35	2	2
	22 kW	35	35	2	2
	30 kW	50	50	1/0	1/0
	37 kW	70	70	2/0	2/0
400V	2.2/3.7 kW	2.5	2.5	12	12
	5.5 kW	4	4	10	10
	7.5 kW	4	4	10	10
	11 kW	6	6	8	8
	15 kW	10	10	6	6
	18.5 kW	16	16	4	4
	22 kW	16	16	4	4
	30 kW	35	25	3	3
	37 kW	25	25	3	3
	45 kW	50	35	2	2
	55 kW	50	50	1	1
	75 kW	70	70	2/0	2/0
	90 kW	120	120	4/0	4/0
	110 kW	150	150	300	300
132 kW	185	185	350	350	

### 3. Installation and Wiring

Inverter Capacity		Wire Size			
		mm <sup>2</sup>		AWG or kcmil	
		R, S, T	U, V, W	R, S, T	U, V, W
	160 kW	240	240	500	500
	220 kW	400	400	800	800
	280 kW	2 X 240	2 X 240	2 X 500	2 X 500
	315 kW	2 X 240	2 X 240	2 X 500	2 X 500
	375 kW	2 X 300	2 X 300	2 X 600	2 X 600
	500 kW	2 x 400	2 x 400	2 x 800	2 x 800

1) Apply the rated torque to terminal screws. Loose screws can cause of short circuit or malfunction.

Tightening the screws too much can damage the terminals and cause a short circuit or malfunction.

② Grounding Wire Size and Caution to be taken

- Be sure to ground the motor and the inverter to prevent electric shock injury. (200V class: ground impedance 100Ω, 400V class: ground impedance 10Ω)
- Connect the inverter ground to the ground terminal exclusively used for the inverter. Do not use the case of inverter or sash screw for ground.
- It is strongly recommended that as thick a grounding wire as possible be used and wire be short.

Motor Capacity	Ground wire size( mm <sup>2</sup> )	
	200V Class	400V Class
2.2 ~ 3.7 kW	4	2.5
5.5 ~ 7.5 kW	6	4
11 ~ 15 kW	16	10
18.5 ~ 22 kW	25	16
30 ~ 37 kW	25	16
45 ~ 75 kW	-	25
90 ~ 132 kW	-	35
160 ~ 220 kW	-	95
280 ~ 315 kW	-	185
375 ~ 500 kW	-	240

3.3.5 Wiring DC Reactor (Option) (AC power input: 30kW and higher)

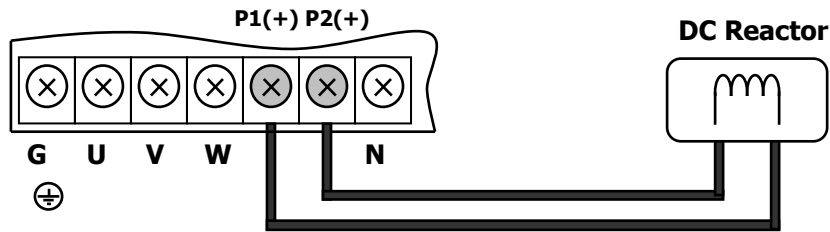

3.3.6 Wiring DB Unit (Option) (AC power input: 30kW and higher)

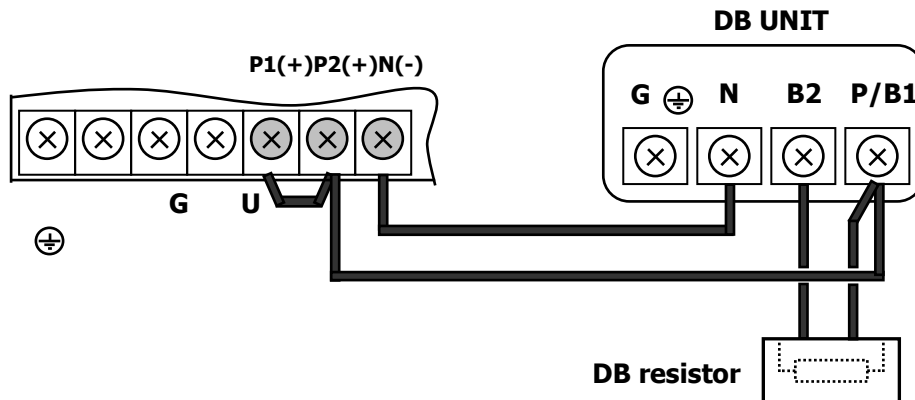

3.3.7 Wiring guide when using both of DC reactor (Option) and DB Unit(option) (AC power input: 30kW and higher)

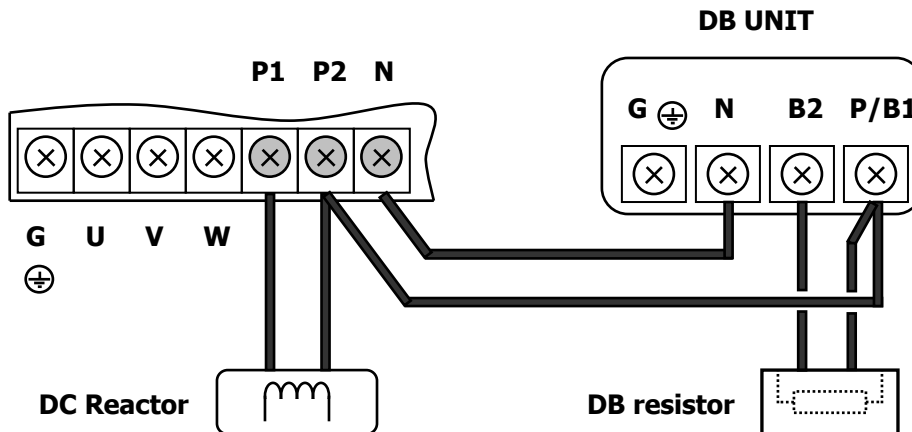

### 3. Installation and Wiring

#### 3.4 Control Board and Terminal

##### 3.4.1 Control circuit terminal arrangement

###### ■ SV022 ~ 5000iV5

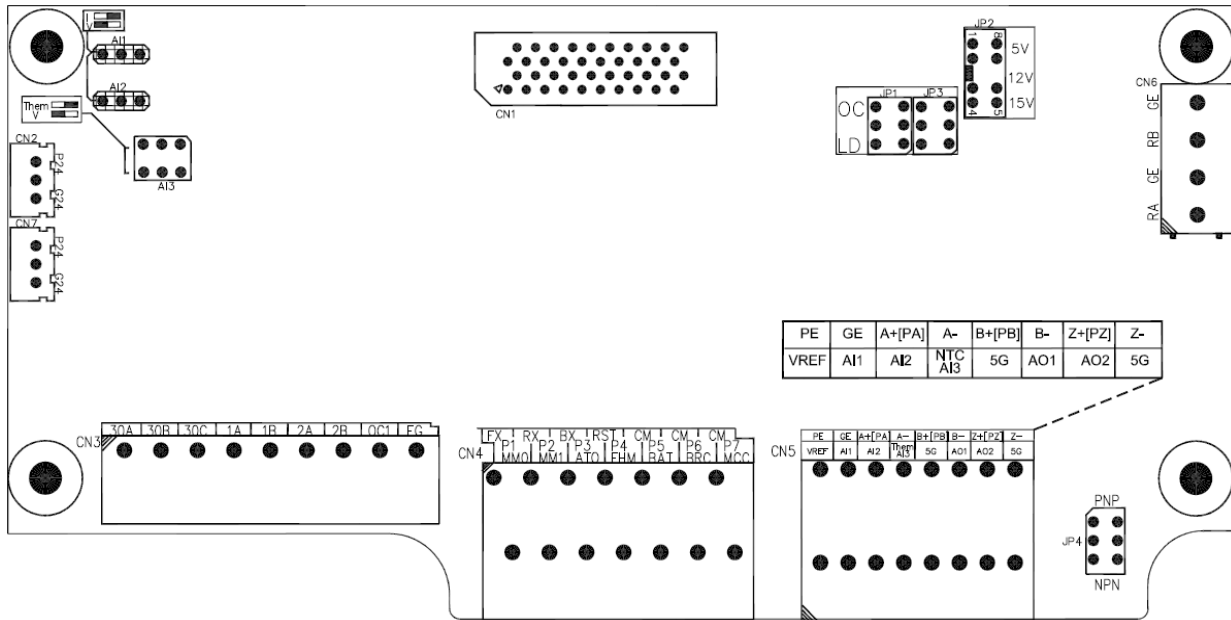

3.4.2 Control circuit terminal function description

Item	Name	Function	Description
Contact Input	FX	Forward Run/Stop Command	<ul style="list-style-type: none"> <li>● Forward/Reverse RUN Command is ON when closed to CM in NPN input mode.</li> </ul>
	RX	Reverse Run/Stop Command	<ul style="list-style-type: none"> <li>● Motor stops when FX/RX is ON or OFF at the same time.</li> </ul>
	BX	Emergency Stop	<ul style="list-style-type: none"> <li>● ON when closed to CM in NPN input mode, Free-run to Stop and deceleration to stop. It does not trigger fault alarm signal.</li> </ul>
	RST	Fault Reset	<ul style="list-style-type: none"> <li>● Resets when fault condition is cancelled.</li> </ul>
	P1 (MM0)	Multi-function input contact	<ul style="list-style-type: none"> <li>● A function can be selected among 47 different functions as shown below. (Multi-step speed 1 / 2 / 3, Jog, MOP Up / Down / Save / Clear, Analog Hold, Main Drive, 2nd function, Accel./Decel. Time selection, 3 Wire RUN, External trip (B contact), Power failure prevention, Reverse rotation prevention, Process PI Disable, Timer input, Soft start cancel, ASR P/PI Gain switch-over, ASR P/PI switch-over, Flux command value switch-over, Pre-excitation, Speed/Torque control, Torque limit ON/Off, Torque bias ON/Off, Battery operation On/Off, Low voltage trip detection prevention, etc.)</li> </ul>
	P2 (MM1)		
	P3 (AT0)		
	P4 (FHM)		
	P5 (BAT)		
	P6 (BRC)		
P7 (MCC)			
CM	COMMON	<ul style="list-style-type: none"> <li>● In NPN input mode, it turns On when each contact is closed to CM terminal.</li> <li>● In PNP input mode, it turns On when each contact is closed to external 24V input.</li> </ul>	
Analog Input	VREF	Power supply for analog setting	<ul style="list-style-type: none"> <li>● Reference voltage by variable resistor ( + 10V ) : 10kΩ</li> </ul>
	AI1	Voltage/ Current Signal Input	<ul style="list-style-type: none"> <li>● Voltage input (-10→10V, 10→-10V, 0→10V, 10→0V)</li> </ul>

### 3. Installation and Wiring

Item	Name	Function	Description
	AI2		<ul style="list-style-type: none"> <li>● Motor NTC is selectable function.</li> <li>● Jumper setting in Voltage Input: <b>Jumper set as default</b> <ul style="list-style-type: none"> <li>→ AI1, AI2: Jumper set on left side,</li> <li>AI3: Switch set on left("V") side</li> </ul> </li> <li>● Jumper setting in Current Input                             <ul style="list-style-type: none"> <li>→ AI1, AI2: Jumper set on right side</li> </ul> </li> <li>● S/W setting in motor NTC (Higen motor)                             <ul style="list-style-type: none"> <li>→ AI3: switch set on right ("Them") side.</li> </ul> </li> <li>● Selectable 17 functions as following: (Speed, Process PID controller, Process PI controller feedback, Draw, Torque, Magnetic flux, Torque bias, Torque limit, Motor NTC, etc.)</li> </ul>
	AI3/ Them	Voltage input Motor NTC Input	
	5G	COMMON	● COMMON terminal for Analog input
Encoder Input	PE	P/S (Power supply) for Pulse Encoder	+5V Line Drive Power
	GE		0V
	A+	Encoder A-phase signal	<ul style="list-style-type: none"> <li>● A, B signal for Line Drive Type Encoder.</li> <li>● Set the JP2 switch at "P5" on I/O PCB and set the JP4 switch to "LD" for the use of Line Drive.</li> <li>✳ <b>Jumper set as default</b></li> </ul>
	A-		
	B+	Encoder B-phase signal	
	B-		
	PE	P/S for Open Collector	+15V Open Collector Power
	GE		0V
	PA	Encoder A-phase signal	<ul style="list-style-type: none"> <li>● A, B signal for Complementary or Open Collector Type Encoder.</li> <li>● Set the JP2 switch at "P15" on I/O PCB and set the JP4 switch to "OC" for the use of Open Collector.</li> </ul>
	PB	Encoder B-phase signal	
	Z+ (PZ)	Encoder Z-phase signal	<p><b>Caution) The usages of Z-phase signal are as follows and its functions will be available soon.</b></p> <ul style="list-style-type: none"> <li>● Use for Z-phase pulse provided encoders.</li> <li>● Z+ and Z- signals are used for Line Drive type, so set the JP5 switch to "LD".</li> <li>● PZ signal is used for Open Collector type, so set the JP5 switch to "OC".</li> </ul>
	Z-		

Item	Name	Function	Description
Encoder Output	RA	Encoder signal output : A-phase	Encoder A, B phase signal output – Open Collector Type <sup>Note1)</sup>
	GE	Output Common	
	RB	Encoder signal output : B-phase	
	GE	Output Common	
Analog Output	AO1	Analog Output 1	<ul style="list-style-type: none"> <li>● -10V → 10V, 10 → -10V, 0 → 10V, 10 → 0V output</li> <li>● Selectable among 39 functions (Analog input value, Pre Ramp Reference, Post ramp reference, ASR Input Reference, Motor Rotating Speed, Speed Deviation, ASR Output, Torque bias, Positive Trq Limit, Negative Trq Limit, Regeneration Trq Limit, Torque Reference, Torque Output Torque current ref., Torque current, Flux reference, Flux Current ref. , Flux Current, ACR output of axis Q, ACR output of axis D, Voltage reference of axis D, Voltage reference of axis Q, Output current, Output voltage, Output power, DC LINK voltage, Process PI reference, Process PI Feedback, Process PI output, Motor temperature, Motor temperature, Inverter temperature, Inverter i2t)</li> </ul>
	AO2	Analog Output 2	
	5G	COMMON	
Relay Output	1A	Multi-function relay output 1 (A Contact)	<ul style="list-style-type: none"> <li>● Selectable among the following 22 functions; (Inverter ready, Zero speed detection, Seed detection, Speed detection (ABS), Speed arrival, Timer out, Low voltage alarm, run, regenerating, Motor overheat warning, Inverter overheat warning, Speed agree, Torque detection, Torque limit detection, Overload warning, Stop, Steady run, Brake output, WEB brake, UP to speed, False core, MC output)</li> </ul>
	1B		
	2A	Multi-function relay output 2 (A Contact)	
	2B		
	OC1	Open Collector Output	
	EG		

### 3. Installation and Wiring

Item	Name	Function	Description
	30A	Fault alarm A contact	<ul style="list-style-type: none"> <li>●Outputs when fault occurs.</li> <li>●Deactivated in BX condition.</li> </ul>
	30B	Fault alarm B contact	
	30C	COMMON	
Switch	JP1	Encoder Input- pulse Type	LD (Line Drive) / OC (Open Collector or Complementary)
	JP2	Encoder Power Supply	DC +5V / +12V / +15V selectable usages
	JP4	PNP/NPN Input mode	PNP/NPN contact input mode selection

Note)

1) Example wiring of Encoder output

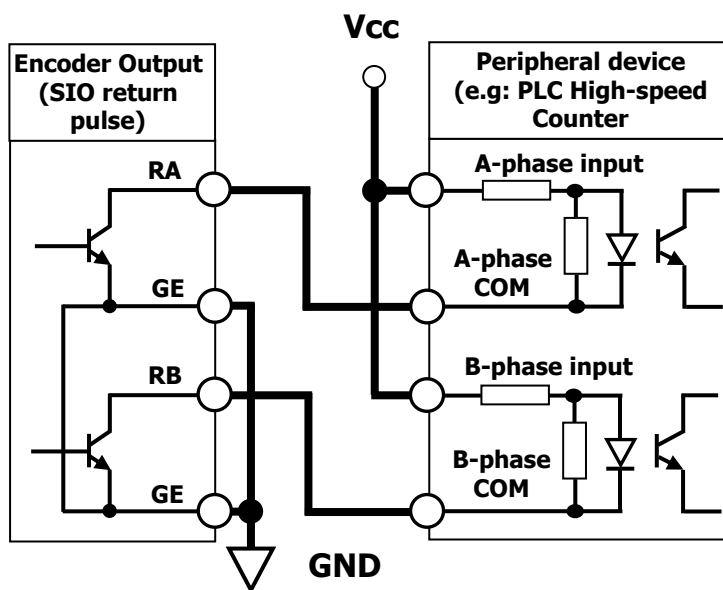

#### Warning

Wiring must be considered with input circuit . Because encoder output is open collector type. The figure is shown the wiring when inverter is connected with High-speed counter of LS ELECTRIC PLC.



● **Additional Functions of Extended I/O(EXTN \_ I/O) Control board terminal**

Item	Name	Function	Description
Analog Input	AI1	Voltage Input Current Input	<ul style="list-style-type: none"> <li>● Extended I/O(EXTN_I/O) board is added analog input <u>AI4, AI5.</u></li> <li>● How to use terminal Pin :                             <ul style="list-style-type: none"> <li>- Voltage Input : AI1, AI2,AI3, AI4, AI5</li> <li>- Current Input : AI1, AI2, AI3, AI4</li> <li>- Motro NTC input : AI5</li> </ul> </li> <li>Note) Jumper setting and functions are explained at I/O control terminal description.</li> </ul>
	AI2		
	AI3		
	AI4		
	AI5/ Them	Voltage Input Motor NTC Input	
	5G	COMMON	

## 3. Installation and Wiring

### 3.4.3 Wiring the control circuit terminal

- ① Shield wire or vinyl insulated wire are highly recommended to be used for the control circuit terminal.
- ② Be sure to use twisted shield wire if wiring distance gets too long.
- ③ Wire should be at least as thick as  $0.2 \sim 0.8 \text{ mm}^2$  (18 ~ 26 AWG).
- ④ Screwing torque limit should be kept under 5.2 lb-in.
- ⑤ Maximum interrupting capacity of auxiliary contact 1, 2 is of AC 250V/1A, DC 30V/1A.
- ⑥ Maximum interrupting capacity of fault alarm relay A, B contact is of AC 250V/1A, DC 30V/1A.
- ⑦ Open collector output 1, 2, 3 and encoder output can be used below maximum of 24V/100mA.
- ⑧ Wires for the control circuit terminal should be separated from ones for the power circuit terminal, if possible and in case wires for both control circuit terminal and the power circuit one cross each other, they should be crossed at right angles ( $90^\circ$ ).

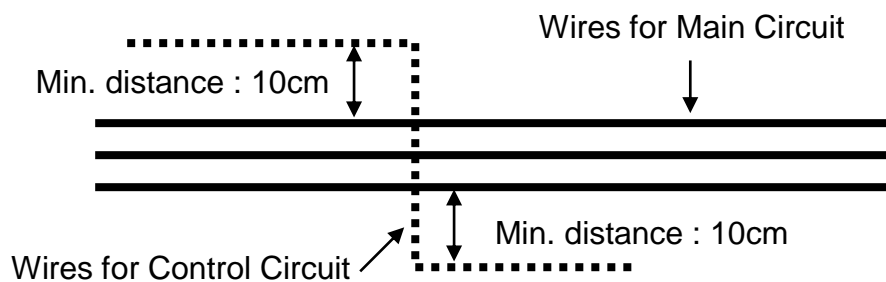

### 3.4.4 Caution on wiring pulse encoder

- 1) Check-up of the coupling and alignment of motor and encoder shaft
  - ① Be sure to mount the pulse encoder at the location where it rotates at the same speed as the motor does.  
(e.g. on the opposite shaft of load side of motor, on the opposite shaft of motor at traction machine)
  - ② In case there is speed slip between the motor shaft and encoder shaft, the motor may not start or it causes mechanical vibration.
  - ③ Poor alignment of motor and encoder shaft results in torque ripple and causes mechanical vibration which has the same frequency as the motor speed at the constant speed region.
- 2) Wiring the pulse encoder
  - ① Be sure to use twist paired shield wire and ground shield wire to screw for earth on the I/O PCB.
  - ② Signal wires should be separated from the power lines, if possible.  
Electromagnetic noise may affect the pulse encoder output signals.

#### 3.4.5 Encoder wiring and switch setting method (+15V Complementary / Open Collector Type)

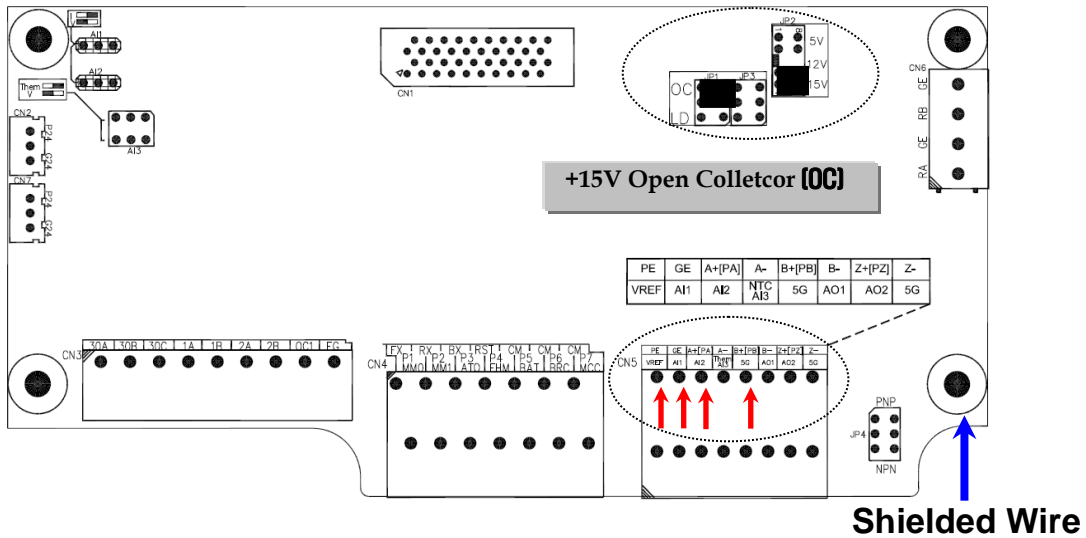

#### 3.4.6 Encoder wiring and switch setting method (+5V Line Drive)

※ Jumper set as default

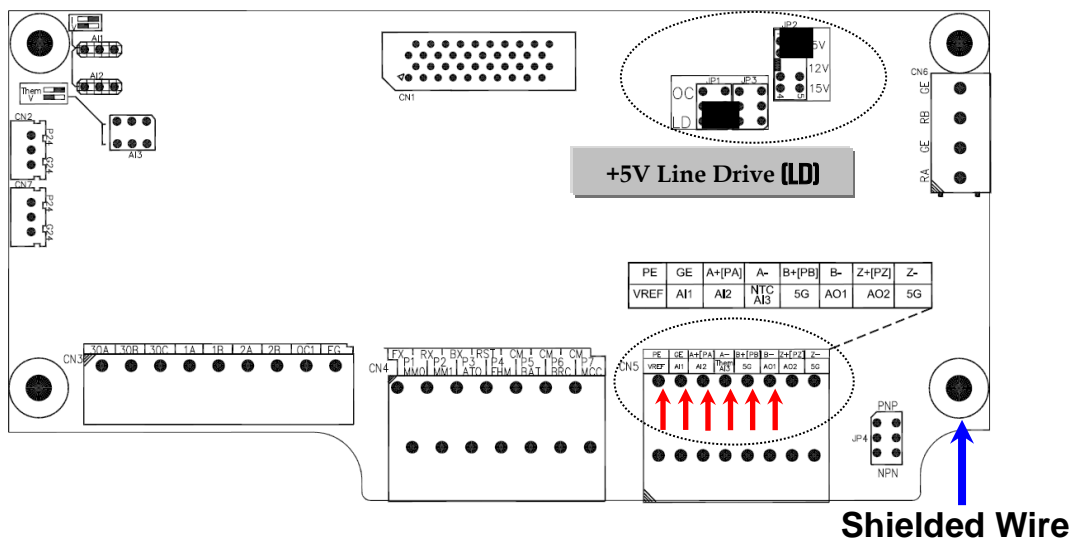

#### ⚠ CAUTION

- NEVER change the switch setting for Encoder Type during inverter run. Otherwise, it may cause inverter trip, adversely affecting the entire system. Therefore, verify the switch is correctly set before operation.

### 3. Installation and Wiring

#### 3.4.7 Analog input jumper setting (Voltage/Current/Motor NTC Input) and PNP/NPN input mode switch setting

※ Jumper set as default : Voltage Input (Left)

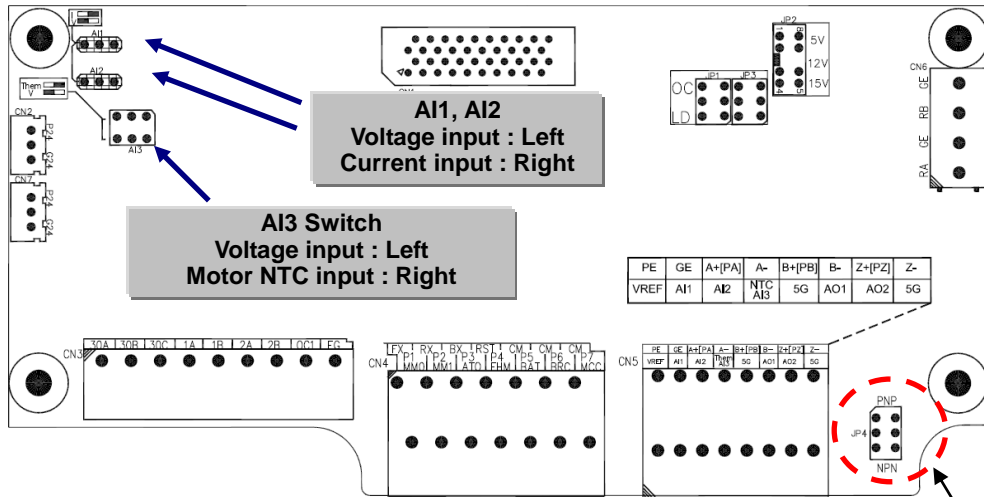

※ Factory Default Jumper Setting: NPN (down side)

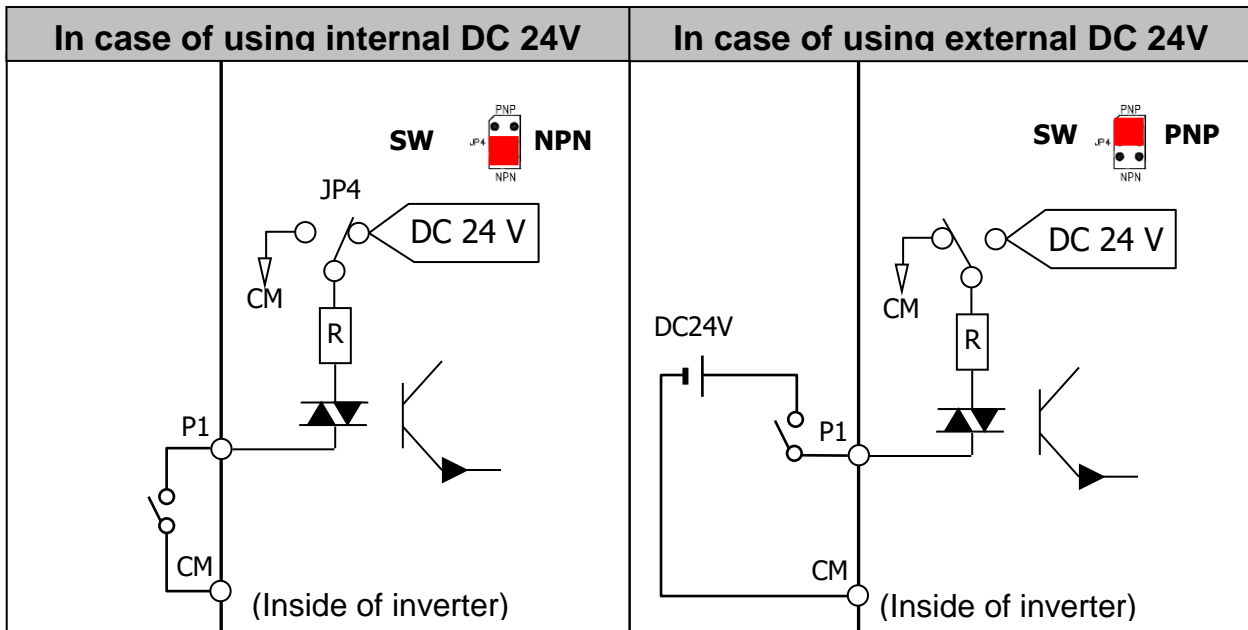
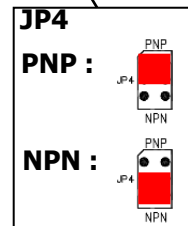

- Guaranteed PNP type input voltage (external DC 24V): On voltage (DC 19~25.2 V)/ Off voltage (DC 7V or less)



## CAUTION

- NEVER change the jumper setting during inverter run. Otherwise, it may cause inverter trip, adversely affecting the entire system.
- Motor NTC input for Analog Input 3 (AI3) is ONLY available when OTIS Motor is connected.  
If user use a motor other than Higen motor with different NTC specification and use this function, it will lead to motor overheat and damage to the motor.
- Do not change the setting of PNP/NPN input switch during inverter operation. It can influence to the system since contact input is changed. Set the switch correctly before inverter operation.

## 3.5 Terminal of the Auxiliary Power Supply

### 3.5.1 The position of the terminal

- SV110 ~ 750iV5(Press) (for AC/DC products)

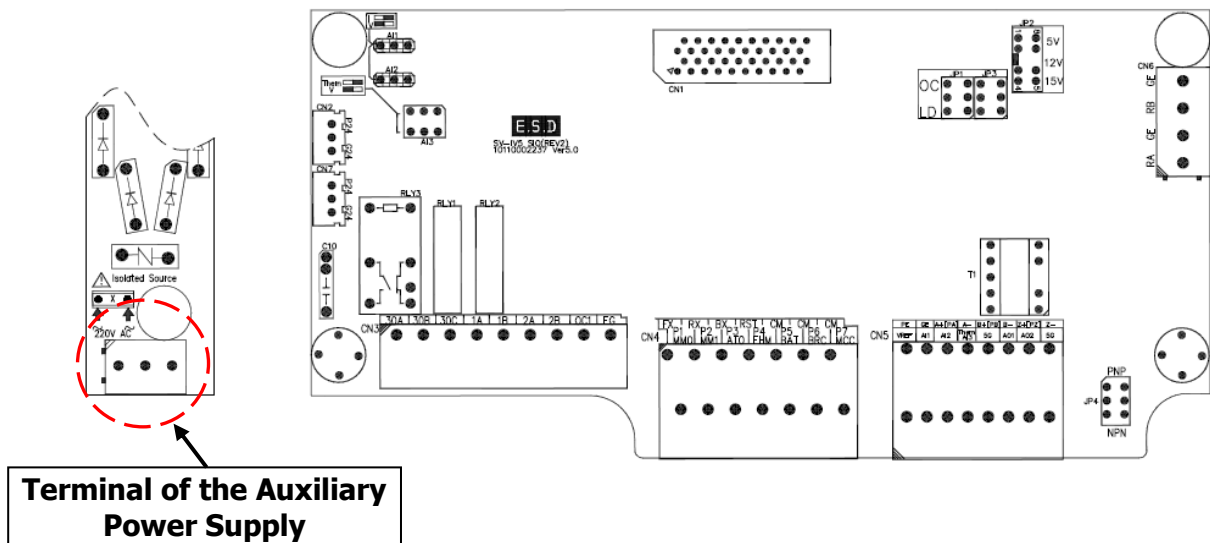

### 3. Installation and Wiring

#### ■ SV055 ~ 075iV5-4(Mold)

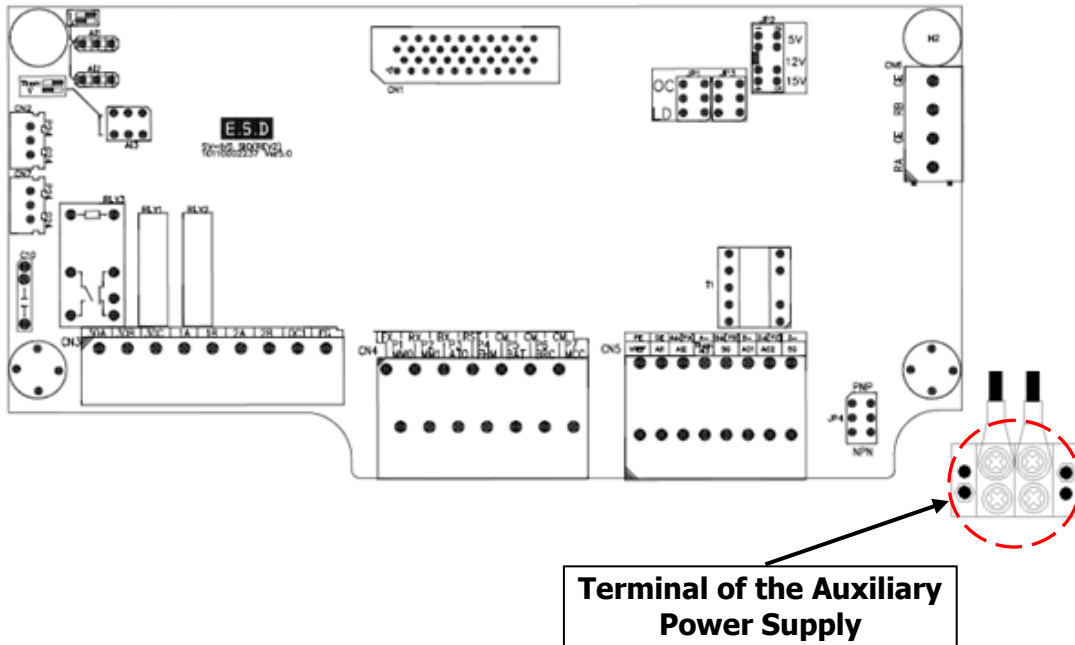

#### ■ SV110 ~ 220iV5-4(Mold)

#### ■ SV900 ~ 2200iV5(Press) (for AC/DC products)

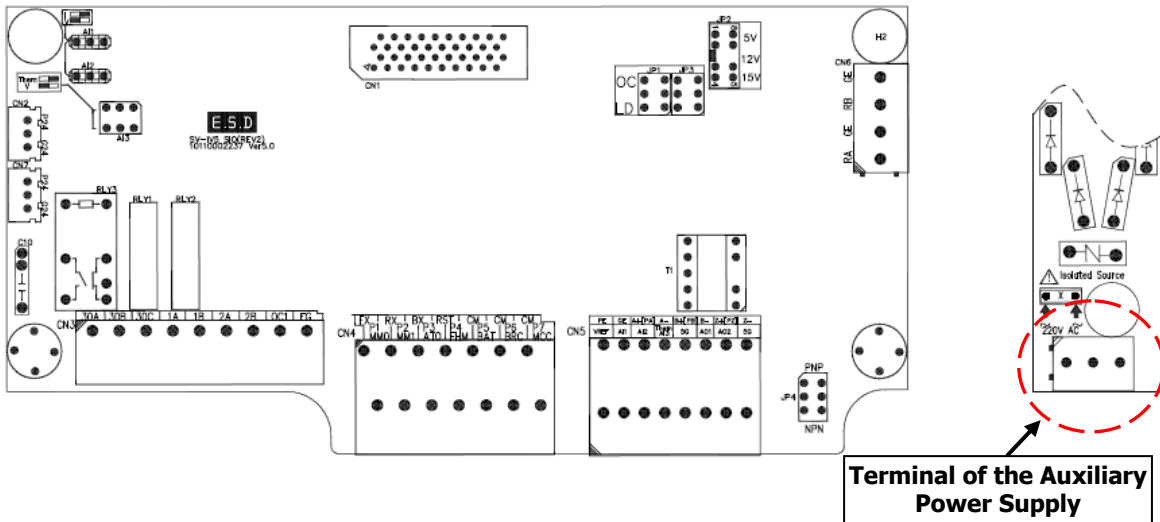

■ **SV2800 ~ 5000iV5(Press)** (for AC/DC products)

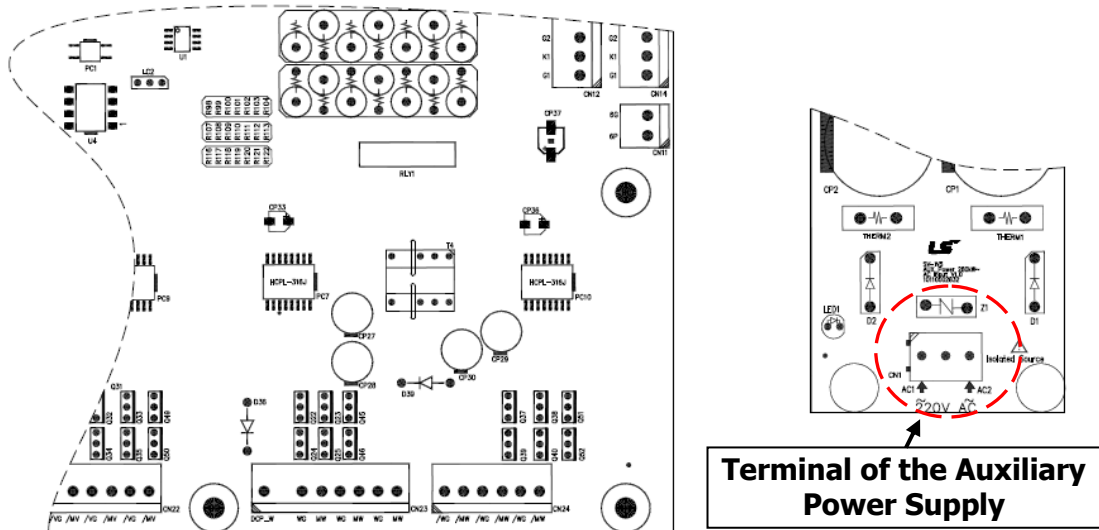

#### 3.5.2 Function description of auxiliary terminal block

Symbol	Terminal Name	Terminal Description	Input Power
AC1, C2	Auxiliary power input	Inputs single-phase AC input source	220V (-10 ~ +10%), 50/60Hz

#### 3.5.3 Wiring and Precaution of auxiliary terminal block

- ① Connect the auxiliary power supply through insulated transformer separated with main power supply.
- ② User polyvinyl chloride insulated wire for auxiliary power cable.
- ③ Use the cable above 0.5mm<sup>2</sup> (20 AWG).

## Chapter 4 - Trial Operation

### 4.1 Keypad Operation

LCD Keypad can display up to 32 alphanumeric characters and monitor or set parameter values to operate the inverter and the motor properly. As follows are keypad view and explanation on each key/LED on the keypad.

#### <Keypad View>



Items	Name	Function	Description
Key	MODE	Mode	Enables to move to the other groups (Initial Screen →DIO → PAR → FUN...) and go to the first code in the same group.
	PROG	Program	Enables to modify setting values.
	ENT	Enter	Enables to move to the other groups (Initial Screen ← DIO ← PAR ← FUN...) and save the changed setting values.
	▲(Up)	Up	Moves to the next code or increments setting values.
	▼(Down)	Down	Moves to the next code or decrements setting values.
	SHIFT/ESC	Shift/ESC	Acts as Shift key in a setting mode and as ESC key in other mode.
	REV	Reverse RUN	Reverse RUN command is enabled.
	STOP/RESET	Stop/Reset	Stop key during inverter operation. Resets fault when inverter returns to normal after fault has occurred.
	FWD	Forward RUN	Forward RUN command is enabled.
LED	(REV)	Reverse RUN	Lit when motor is in reverse revolution. Blinks on acceleration/deceleration, lit in a constant speed.
	(STOP/RESET)	Stop/Reset	Lit when the motor stops. Blinks when fault has occurred.
	(FWD)	Forward RUN	Lit when motor is in forward revolution. Blinks on acceleration/deceleration, lit in a constant speed.



## 4. Trial Operation

### 4.2 Keypad LCD Display

#### 4.2.1 LCD Start-up display

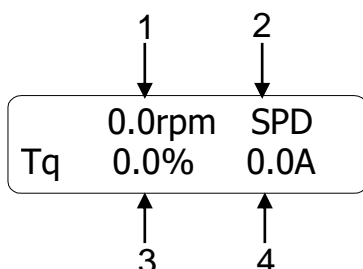

No.	Function	Description
1	Motor speed	Real motor speed in RPM (Revolution Per Minute)
2	Motor control Mode	SPD : Speed control mode TRQ : Torque control mode WEB : WEB control mode SLS : Sensorless control mode BX : Emergency stop BAT : Battery-operated mode
3	Generating torque	Displays % ratio to the rated torque of a motor.
4	Output current	Inverter output current in RMS

#### 4.2.2 Group display

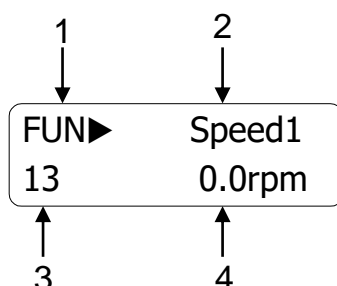

No.	Function	Description
1	Parameter group	Displays the name of each parameter group. There are DIS, DIO, PAR, FUN, CON, AIO, USR and 2 <sup>nd</sup> group, etc..
2	Code name	Displays a code name to be set.
3	Code Number	Displays a code number to be set.
4	Code data and unit	Displays a code data and a code unit to be set.

### 4.3 Setting of Parameter Values

In case inverter is to be in use using a keypad, proper parameter values can be set depending on the load and operation condition.

First, move on to the code in a group where is intended to change parameter value. Cursor (■) blinks by pressing [**PROG**] key. Parameter value can be set using (SHIFT/ESC), [**▲** (Up)] and [**▼** (Down)] keys and then can be saved by entering [ENT] key.

Note) In some cases, data will not be changed for the following two reasons.

- \* Some data cannot be changed during inverter operation.
- \* Parameter data lock function is set. (PAR\_04 [Parameter Lock] is enabled)

Example) In case the 1st acceleration time is to be changed from 10(sec) to 15(sec), it can be set as shown below.

0.0rpm SPD Tq 0.0% 0.0A	Initial Display
FUN▶ Jump code 00 1	Move to FUN Group by using [MODE] Key
FUN▶ Jump code 00 40	Press [PROG] Key → Enter 40 by [(SHIFT/ESC)], [ <b>▲</b> (Up)], [ <b>▼</b> (Down)] Key →[ENT]
FUN▶ Acc Time-1 40 10.00 sec	Acc time 1 is settable.
FUN▶ Acc Time-1 40 ■10.00 sec	Press [PROG] Key. Setting Mode(Cursor(■) appears and blinks)
FUN▶ Acc Time-1 40 10.00 sec	Move the Cursor(■) to the position to be changed using [(SHIFT/ESC)] key.
FUN▶ Acc Time-1 40 15.00 sec	Set the data using [ <b>▲</b> (Up)], [ <b>▼</b> (Down)] key.
FUN▶ Acc Time-1 40 15.00 sec	Save the changed data by pressing [ENT] key. (Cursor disappears.)

## 4. Trial Operation

### 4.4 Data Groups

SV-iV5 series inverters use LCD keypad for user's convenience. Data groups are divided into 12 groups for easy access depending on the inverter application.

Name	LCD keypad (on the upper left)	Description
Display group	DIS	Motor speed, Motor control mode, Generating torque, Output current, User selection display, Process PID output/reference/feed-back value, Fault display, User group display setting and so on.
Digital I/O group	DIO	Digital Input /Output parameters and so on.
Parameter group	PAR	Parameter initialization, Parameter read / write / lock /password, Constant which is motor related, Auto-tuning and so on.
Function group	FUN	Operating frequency, Operation mode, Stop mode, Acceleration /deceleration time and pattern, Carrier frequency, Electronic thermal selection and so on.
Control group	CON	Control mode, ASR PI gain, Process PID gain, Draw control setting, Droop control related constants, Torque control related constants, V/F control related constants and so on.
Exterior group	EXT	Built-in 485 communication parameter and communication parameter when the exterior option board is installed.
Analog I/O group	AIO	Analog Input /Output Parameter and so on.
User group	USR	User macro function, macro function save, macro function recall
2 <sup>nd</sup> function group	2 <sup>nd</sup> 2)	2 <sup>nd</sup> motor control mode, 2 <sup>nd</sup> motor accel./decel. time, 2 <sup>nd</sup> motor parameters and so on.
Elevator group	E/L 2)	It is displayed when EL_I/O option board is installed, Elevator operation function setting parameter and so on.
Synchronous group	SYNC 2)	It is displayed when SYNC_I/O option board is installed. Synchronous operation function setting parameter and so on.
WEB group	WEB 2)	Diameter and Tension control setting parameter while WEB control.
Sensorless control group	SLS 2)	Open Loop control setting parameter which is not using the position sensor as encoder, resolver and, etc..

1) **Group name:** It is displayed when option board is installed, Refer to the option manual for more details.

2) It is displayed when the option board is installed and CON (control) mode is changed to it. Refer to the user manual related to the option board.

● **Group transfer in the keypad**

For transfer to another group, [MODE] key is used and ▲(Up), ▼(Down) key is used to move up and down in the same group.

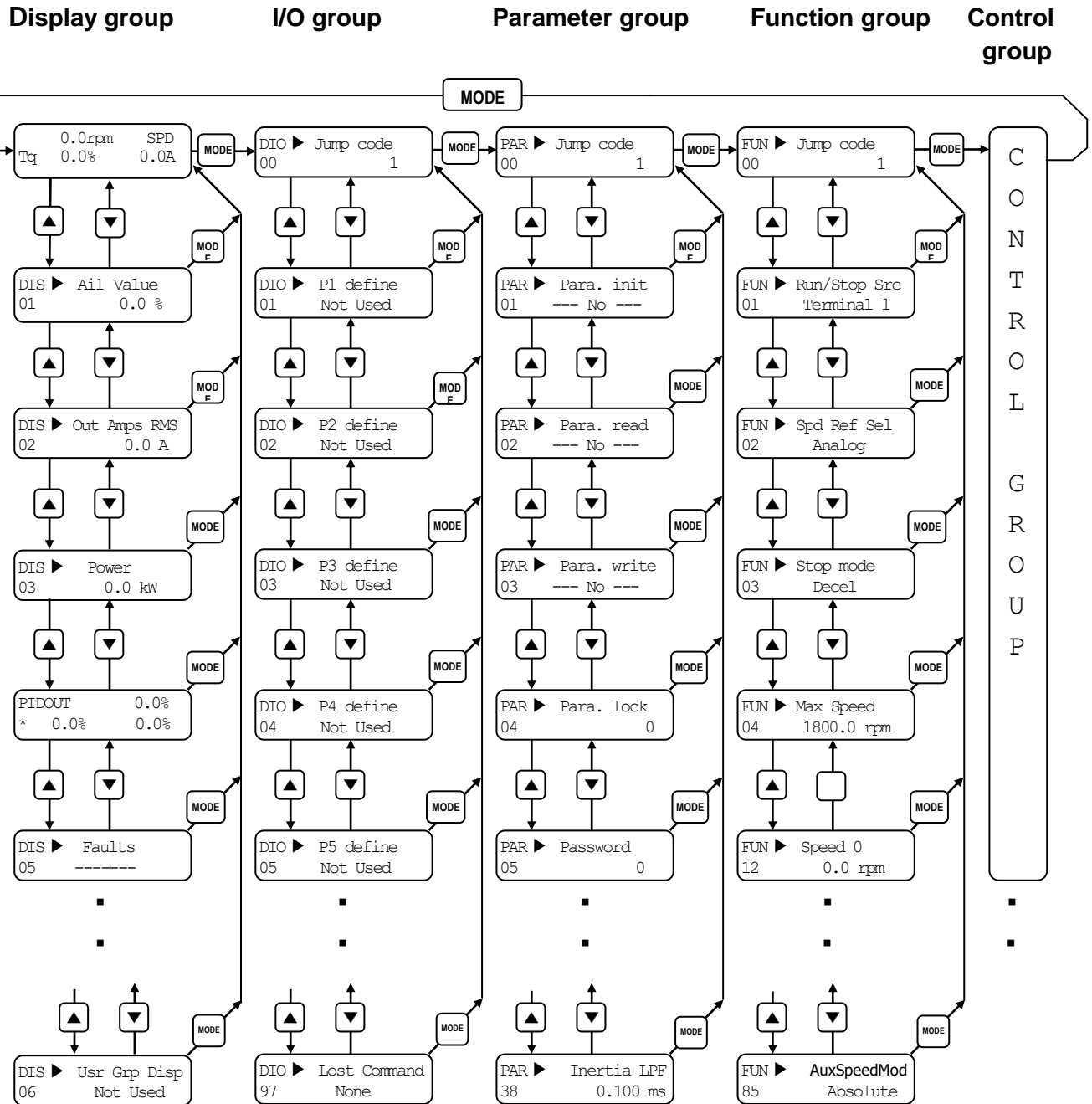

● In these group transfers, User Group, 2<sup>nd</sup> Group, AIO Group, EXT group and WEB Group are omitted.

## 4. Trial Operation

### 4.5 Auto-Tuning

Parameters such as stator resistance ( $R_s$ ), stator leakage inductance ( $sL$ ), flux current ( $I_F$ ), rotor time constant ( $\tau_r$ ) and stator self-inductance ( $L_s$ ) are indispensable for obtaining an excellent control performance in the vector control and are automatically measured and set using auto-tuning function.

- SV-iV5 features two types of Auto-tuning:
  - 1) Rotational Auto Tuning
  - 2) Standstill Auto Tuning

#### 4.5.1 Motor and encoder parameter setting for auto-tuning

The Motor capacity, Basic speed, Rating voltage, Pole number, Efficiency, Rating slip and Rating current on the nameplate of the motor and the pulse number of encoder should be set before operation.

LCD Display	Description
PAR ► Motor select 07 kW	<ul style="list-style-type: none"> <li>● Enter the motor capacity.</li> <li>● Basic capacity is same with Inverter capacity</li> <li>● Enter directly in the PAR_08 after selecting "User Define" if there is no Motor capacity.</li> </ul>
PAR ► UserMotorSel 08 kW	<ul style="list-style-type: none"> <li>● Enter the motor capacity directly at PAR_08 incase that select "User Define" at PAR_07.</li> </ul>
PAR ► Enc Pulse 10 [ ] [ ] [ ] [ ]	<ul style="list-style-type: none"> <li>● Set the pulse numbers per revolution of pulse encoder coupled to the motor shaft.</li> </ul>
PAR ► Base Speed 17 rpm	<ul style="list-style-type: none"> <li>● Set the motor base speed. Note) It is not rating current of name plate. Base Speed = <math>120 \times \text{Base Frequency} / \text{Pole number}</math></li> </ul>
PAR ► Rated Volt 18 V	<ul style="list-style-type: none"> <li>● Set the rated voltage of the motor. (Voltage value on the name plate)</li> </ul>
PAR ► Pole number 19 [ ]	<ul style="list-style-type: none"> <li>● Set the number of poles of the motor.</li> </ul>
PAR ► Efficiency 20 %	<ul style="list-style-type: none"> <li>● Set the efficiency of the motor. If you cannot find the efficiency in name plate, Do not set the Efficiency.</li> </ul>
PAR ► Rated-Slip 21 rpm	<ul style="list-style-type: none"> <li>● Set the rated slip speed of the motor. (Rated slip=synchronous speed–rated speed)</li> </ul>
PAR ► Rated-Curr 22 A	<ul style="list-style-type: none"> <li>● Set the rated current of the motor.</li> </ul>

## 4.5.2 Rotational auto-tuning

### 1) Precautions

 <b>CAUTION</b>
Be sure to remove the load connected to the motor shaft before performing rotational auto-tuning. Otherwise, it may lead to damage to the motor or bodily injury. DB resistor should be installed because the inverter repeats abrupt Accel/Decel many times to find the motor constant (Tr) during tuning.

### 2) Rotational Auto-tuning procedure

LCD Display	Description	Tuning Time
PAR ▶ AutoTuneType 24 Rotational	Set it to “ <b>Rotational</b> ”.	-
PAR ▶ Auto tuning 25 ALL1	Auto-tuning starts when it is set to “ <b>ALL1</b> ”.	-
PAR ▶ Auto tuning 25 Enc Testing	Checks whether the encoder wiring is properly done and an encoder works well by rotating the motor at 1500 rpm in forward direction.	30 ~ 35(Sec)
PAR ▶ Auto tuning 25 Rs Tuning	Stator resistance (Rs) is measured without rotating the motor.	10 ~ 20(Sec)
PAR ▶ Auto tuning 25 sL Tuning	The leakage inductance (sL) of the motor is measured without rotating the motor.	5 ~ 20(Sec)
PAR ▶ Auto tuning 25 IF Tuning	The flux current (IF) is measured by rotating the motor at 1500 rpm.	30 ~ 60(Sec)
PAR ▶ Auto tuning 25 Ls Tuning	Stator self-inductance (Ls) is measured by rotating the motor at 1500 rpm.	50 ~ 60(Sec)

## 4. Trial Operation

LCD Display	Description	Tuning Time
<div style="border: 1px solid black; border-radius: 10px; padding: 5px; width: fit-content;">                     PAR ▶ Auto tuning                      25      Tr Tuning                 </div>	Accel/Decel is performed repeatedly to find motor constant (Tr) so that DB Resistor should be connected before starting tuning. Otherwise, "Over Voltage " trip will occur.	20 ~ 60(Sec)
<div style="border: 1px solid black; border-radius: 10px; padding: 5px; width: fit-content;">                     PAR ▶ Auto tuning                      25      None                 </div> <div style="border: 1px solid black; border-radius: 10px; padding: 5px; width: fit-content;">                     PAR ▶ Auto tuning                      25      [[]] Error                 </div>	When auto-tuning is complete successfully, "None" is displayed. If error occurs during auto-tuning, "[[]] Error" is displayed. In this case, <b>verify motor parameters and encoder setting is done properly</b> and redo the auto-tuning. If the problem persists, contact LS representative.	<p style="text-align: center;"><b>Total 3 ~ 5 (Min.) is required</b></p>

- FWD/REV LED on keypad will blink during Auto-tuning.
- If setting PAR\_24 (Auto tuning) to " ALL2 ", all procedure is same as "ALL1" except Encoder Testing will be skipped.
- Motor constants of each can be selected and separately tuned.  
(Encoder Test, Rs Tuning, Lsigma, Flux Curr, Ls Tuning, Tr Tuning)
- If encoder phase (A, B) or inverter output wiring is switched during Auto-tuning, " Enc AB Chgd " message will be displayed. In this case, changing PAR\_11 (Enc Dir Set) setting from "A Phase Lead" to "B Phase Lead" (or oppositely) will erase the need for changing the wiring.

### 4.5.3 Standstill auto tuning

#### 1) Precaution

Be sure to lock the motor shaft using magnetic brake.

#### 2) StandStill Type Auto-tuning procedure

LCD Display	Description	Tuning Time
<div style="border: 1px solid black; border-radius: 10px; padding: 5px; display: inline-block;">           PAR ▶ AutoTuneType 24 Standstill         </div>	Set the auto-tuning type to “ <b>Standstill</b> ”.	-
<div style="border: 1px solid black; border-radius: 10px; padding: 5px; display: inline-block;">           PAR ▶ Auto tuning 25 ALL1         </div>	Auto-tuning starts if <b>ALL1</b> is set.	-
<div style="border: 1px solid black; border-radius: 10px; padding: 5px; display: inline-block;">           PAR ▶ Auto tuning 25 Rs Tuning         </div>	Stator resistance ( $R_s$ ) is measured without rotating the motor.	20-30 Sec
<div style="border: 1px solid black; border-radius: 10px; padding: 5px; display: inline-block;">           PAR ▶ Auto tuning 25 sL Tuning         </div>	The leakage inductance (sL) of the motor is measured without rotating the motor.	90-150 Sec
<div style="border: 1px solid black; border-radius: 10px; padding: 5px; display: inline-block;">           PAR ▶ Auto tuning 25 If/Tr/Ls         </div>	Flux current (IF), rotor time constant ( $T_r$ ) and stator self-inductance ( $L_s$ ) is measured simultaneously without rotating the motor.	40-70 Sec
<div style="border: 1px solid black; border-radius: 10px; padding: 5px; display: inline-block;">           PAR ▶ Auto tuning 25 None         </div> <div style="border: 1px solid black; border-radius: 10px; padding: 5px; display: inline-block;">           PAR ▶ Auto tuning 25 [[]] Error         </div>	When auto-tuning is complete successfully, “None” is displayed. If error occurs during auto-tuning, “[[]] Error” is displayed. In this case, verify motor parameters and encoder setting is done properly and redo the auto-tuning. If the problem persists, contact LS representative.	Total : 3-5 minutes

- FWD/REV LED on keypad will blink during Auto-tuning.
- Motor constants of each can be selected and separately tuned. (Rs Tuning, Lsigma, If/Tr/Ls Tune)



### 4.6 Pulse Encoder Check

#### 4.6.1 The definition of forward rotation

Forward rotation is of counter-clockwise from the side view of motor shaft.

Motor



#### 4.6.2 Forward rotation check

Be sure to check if positive(+) speed is displayed when inverter power is on and rotates the motor in the forward direction.

+[]].[]rpm	SPD
Tq	% A

#### 4.6.3 Reverse rotation check

Be sure to check if negative(-) speed is displayed when inverter power is on and rotates the motor in the reverse direction.

-[]].[]rpm	SPD
Tq	% A

- If speed is displayed 0.0 rpm or unchanged or speed polarity is reversed, check if wiring for the pulse encoder is properly done.
- In case the motor shaft cannot be rotated with hands, refer to next chapter.

## 4.7 Operation by Keypad

### 4.7.1 Parameter setting for keypad operation to rotate the motor at 100 rpm

FUN▶ Run/Stop Src  
01 Keypad

① RUN/STOP command setting by keypad

FUN▶ Spd Ref Sel  
02 Keypad1

② Operating speed reference setting by keypad

FUN▶ Speed 0  
12 100.0 rpm

③ Operating speed setting

### 4.7.2 Forward / Reverse Run (FWD / REV)

#### ① Low speed operation

- Check if motor speed is +100 rpm in the start-up LCD screen after pressing [FWD] key.

+100.0rpm SPD  
Tq % A

- Check if motor speed is -100 rpm in the start-up LCD screen after pressing [REV] key.

-100.0rpm SPD  
Tq % A

- The following table describes the cases of abnormal rotation due to the incorrect wiring of encoder and/or motor.

Command	Rotating direction	Speed display	Torque display	Wiring Status	
FWD	Forward	+100.0(rpm)	Below +10%	Normal	
REV	Reverse	-100.0(rpm)	Below -10%		
FWD	Forward	-10 ~ -40(rpm)	150%(Torque Limit)	Encoder wiring reversed	Abnormal
REV	Reverse	10 ~ 40(rpm)	-150%(Torque Limit)		
FWD	Reverse	-10 ~ -40(rpm)	150%(Torque Limit)	Phase V and W wiring reversed	
REV	Forward	10 ~ 40(rpm)	-150%(Torque Limit)		
FWD	Reverse	+100.0(rpm)	Below +10%	Encoder and Motor all reversed	
REV	Forward	-100.0(rpm)	Below -10%		

- If A and B phase are reversed, be sure to replace A with B phase wire after checking the pulse encoder wiring. Or user does not need to change wiring if PAR\_11(Enc Dir Set) setting value is changed from "A Phase Lead" to "B Phase Lead".
- If Motor wires are reversed, be sure to replace V with W phase wire after checking the motor output wiring.
- Torque display is on the basis of the no load operation.

## 4. Trial Operation

### ② High Speed Operation

Change the value of FUN\_12 to 1000.0(rpm) and Check the display LCD by pressing [FWD], [REV] keys shown below.

- When pressing [FWD] key ;

+1000.0rpm	SPD	
Tq	%	A

- When pressing [REV] key ;

-1000.0rpm	SPD	
Tq	%	A

## 4.8 Operation by Control Terminal

### 4.8.1 Parameter setting

FUN▶	Run/Stop Src
01	Terminal 1

- ① Setting RUN/STOP command by terminal

FUN▶	Spd Ref Sel
02	Analog

- ② Setting Speed reference by Analog

FUN▶	Max Speed
04	1800.0 rpm

- ③ Setting Max. motor speed

AIO▶	Ai1 Define
01	Speed Ref

- ④ Ai1(Analog input terminal) define

AIO▶	Ai1 Source
02	

- ⑤ Ai1(Analog input terminal) Source define : Select (-10 →10V, 10 →-10V, 0 →10V,10 → 0V, 0 →20mA, 20 → 0mA)

### 4.8.2 Wiring example when issuing speed reference using speed potentiometer on AI1 terminal

Connect the potentiometer to VREF, AI1 and 5G as shown below.

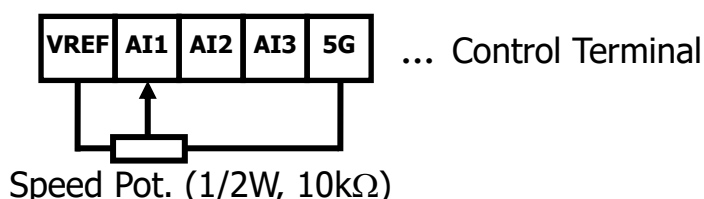

### 4.8.3 Adjusting Ai1 Gain and Bias (example of analog input Ai1 setting)

#### ① Out Y2(Gain) Adjustment of Analog input

- Apply 10V or 20mA between AI1 ~ 5G  
(for setting by potentiometer, adjust it to Max).
- Adjust the other multi analog input terminals in same manner.

Key Handling	Loader Display	Description
	AIO▶ Ai1 Out Y2 06 100.00 %	Initial LCD display
PROG	AIO▶ Ai1 98.00 % 06 Gain 100.00 %	Pressing [PROG] key, shows in upper side the percent of input to output and in low side the gain value be set presently.
▲	AIO▶ Ai1 100.00 % 06 Gain 102.00 %	If you try to adjust the gain to show 100.00%, Press [▲(Up)] key repeatedly and set to be 102.00%.
ENT	AIO▶ Ai1 Out Y2 06 102.00 %	After adjusting Gain, if you enter [ENT] key, the adjusted gain value is saved.

#### ② Out Y1(Bias) Adjustment of Analog input

- Apply 0V or 0mA between AI1 ~ 5G  
(for setting by potentiometer, adjust it to Min).
- Adjust the other multi analog input terminals in same manner.

Key Handling	Loader Display	Description
	AIO▶ Ai1 Out Y1 04 0.00 %	Initial LCD display
PROG	AIO▶ Ai1 0.18 % 04 Bias 0.00 %	Pressing [PROG] key, shows in upper side the percent of input to output and in low side the Bias value be set presently.
▲	AIO▶ Ai1 0.00 % 04 Bias 0.18 %	If you try to adjust the Bias to show 0.00%, Press [▲(Up)] key repeatedly and set to be 0.00%.
ENT	AIO▶ Ai1 Out Y1 04 0.18 %	After adjusting Bias, if you enter [ENT] key, the adjusted Bias value is saved.

## 4. Trial Operation

### 4.8.4 FX / RX operation

#### 1) FX Operation (Forward Run Command by Control Terminal)

- ① Apply 0V between AI1 and 5G (for setting by potentiometer, adjust it to minimum value).
- ② Check the motor speed display in display group shows “+0.0rpm” after connecting the terminals FX and CM.
- ③ Increase AI1 voltage little by little and check the speed is increasing (for setting by potentiometer, turn the pot to maximum value smoothly).
- ④ To stop the motor, disconnect the FX and CM terminal.

#### 2) RX Operation (Reverse Run Command by Control Terminal)

- ① Apply 0V between AI1 and 5G (for setting by potentiometer, adjust it to minimum value).
- ② Check the motor speed display in display group shows “-0.0rpm” after connecting the terminals RX and CM.  
Increase AI1 voltage little by little and check the speed is increasing (for setting by potentiometer, turn the pot to maximum value smoothly).
- ③ To stop the motor, disconnect the RX and CM terminal.

#### 3) The cases of abnormal rotation due to the wrong wiring of encoder and/or motor during low speed (about 100rpm) operation by control terminal.

Command	Rotating direction	Speed display	Torque display	Wiring Status	
FX	Forward	+100.0(rpm)	Below +10%	Normal	
RX	Reverse	-100.0(rpm)	Below -10%		
FX	Forward	-10 ~ -40(rpm)	150%(Torque Limit)	Encoder wiring reversed	Abnormal
RX	Reverse	10 ~ 40(rpm)	-150%(Torque Limit)		
FX	Reverse	-10 ~ -40(rpm)	150%(Torque Limit)	Phase V and W wiring reversed	
RX	Forward	10 ~ 40(rpm)	-150%(Torque Limit)		
FX	Reverse	+100.0(rpm)	Below +10%	Encoder and Motor all reversed	
RX	Forward	-100.0(rpm)	Below -10%		

- If A and B phase are reversed, be sure to replace A with B phase wire after checking the pulse encoder wiring.
- If motor wires are reversed, be sure to replace V with W phase wire after checking the motor output wiring.
- It does not need to change wiring if user changes the setting value of PAR\_11(Enc Dir Set) from “A Phase Lead” to “B Phase Lead”.
- Torque display is on the basis of the no load operation.

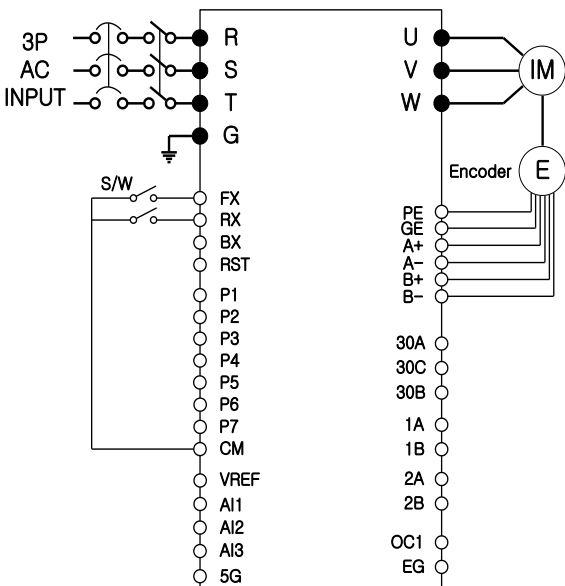
Operation Example (1)	Speed Setting via Keypad + Run/Stop via Terminal (FX/RX)		
<p><b>[Operation condition]</b></p> <ul style="list-style-type: none"> <li>- Control mode : Speed control</li> <li>- Ref. Speed : 1500[rpm] setting via keypad</li> <li>- Accel/Decel time : Accel - 10[sec], Decel - 20[sec]</li> <li>- Run/Stop Src : Run/Stop via FX/RX terminal, Control terminal: NPN mode</li> </ul>			
<p><b>[Wiring]</b></p> 			
Step	Parameter setting	Code	Description
1	RUN/STOP source select	FUN_01	Set it to 0 "Terminal 1".
2	Speed setting method	FUN_02	Set it to 1 "Keypad1".
3	Ref. Speed setting	FUN_12	Set speed command 1500[rpm] via Keypad.
4	Accel/Decel time	FUN_40 FUN_41	Set Accel time to 10 [sec] in FUN_40. Set Decel time to 20 [sec] in FUN_41.
5	Terminal FX	-	Motor starts to rotate in Forward direction at 1500[rpm] with Accel time 10 [sec] when FX terminal is turned ON. Motor decelerates to stop with Decel time 20[sec] when FX terminal is turned OFF.
6	Terminal RX	-	When RX terminal is turned ON motor starts to rotate in Reverse direction at 1500[rpm] with Accel time 10 [sec]. When it is OFF, motor decelerates to stop with Decel time 20 [sec].

## 4. Trial Operation

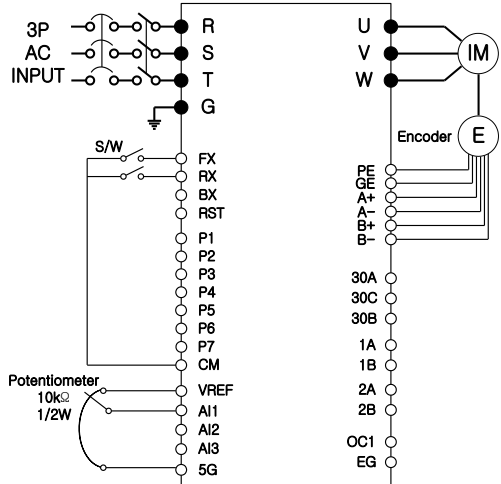
Operation Example (2)	Analog Voltage Input(AI1) + Run/Stop via Terminal (FX/RX)		
<p><b>[Operation condition]</b></p> <ul style="list-style-type: none"> <li>- Control mode : Speed control</li> <li>- Ref. Speed : 1500[rpm] analog input via AI1 (Potentiometer)</li> <li>- Accel/Decel time : Accel - 10[sec], Decel - 20[sec]</li> <li>- Run/Stop Src : Run/Stop via FX/RX terminal, Control terminal: NPN mode</li> </ul>			
<p><b>[Wiring]</b></p> 			
Step	Parameter setting	Code	Description
1	RUN/STOP source select	FUN_01	Set it to 0 "Terminal 1".
2	Speed setting method	FUN_02	Set it to 0 "Analog".
3	Analog Input 1 definition	AIO_01	Set it to 1 "Speed Ref".
4	Analog Input 1 Input Method definition	AIO_02	Set it to 2 "0 → 10V".
5	Ref. Speed setting	DIS_01	Set speed command 1500[rpm] via AI1(Potentiometer) in DIS_01 PreRamp Ref.
6	Accel/Decel time	FUN_40 FUN_41	Set Accel time to 10 [sec] in FUN_40. Set Decel time to 20 [sec] in FUN_41.
7	Terminal FX	-	Motor starts to rotate in Forward direction at 1500[rpm] with Accel time 10 [sec] when FX terminal is turned ON. Motor decelerates to stop with Decel time 20[sec] when FX terminal is turned OFF.
8	Terminal RX	-	When RX terminal is turned ON motor starts to rotate in Reverse direction at 1500[rpm] with Accel time 10 [sec]. When it is OFF, motor decelerates to stop with Decel time 20 [sec].





## Chapter 5 - Function Code Table

\* The number of page is for User's manual uploaded at LSIS website. You can download the User's manual which is described detailed function of parameter from website. (<http://www.lselectric.co.kr>)

### 5.1. Display Group (DIS\_[][])

\* ' - ' mark of communication address indicates communication exclusion.

\* Setting during Inverter operation (Yes : possible, No : impossible)

CODE No.	Comm. Addr.	CODE NAME	LCD DISPLAY	SETTING DATA			Adjustment During Run <sup>1)</sup>
				RANGE	UNIT	DEFAULT	
DIS_00	-	Motor Speed/Control Mode OutputTorque/Output Current	0.0 rpm Tq 0.0%	SPD 0.0A	-	-	
DIS_01	-	User Display 1	Ai1 Value	%	PreRamp Ref	Yes	
			Ai2 Value	%			
			Ai3 Value	%			
			Ai4 Value <sup>1)</sup>	%			
			Ai5 Value <sup>1)</sup>	%			
			PreRamp Ref	rpm			
			PostRamp Ref	rpm			
			ASR Inp Ref	rpm			
			Motor Speed	rpm			
			Motor SpdEst	rpm			
			Speed Dev	rpm			
			ASR Out	%			
			Torque Bias	%			
			PosTrq Limit	%			
			NegTrq Limit	- %			
			RegTrq Limit	%			
			Torque Ref	%			
			Torque	%			
			IqeRef	A			
			Iqe	A			
			Flux Ref	%			
			Ide Ref	A			
Ide	A						
ACR_Q Out	V						
ACR_D Out	V						
VdeRef	V						
VqeRef	V						

## 5. Function Code Table

CODE No.	Comm. Addr.	CODE NAME	LCD DISPLAY	SETTING DATA			Adjustment During Run <sup>1)</sup>
				RANGE	UNIT	DEFAULT	
			Out Amps RMS		A		
			Out Volt RMS		V		
			Power		kW		
			DC Bus Volt		V		
			Proc PI Ref		%		
			Proc PI F/B		%		
			Proc PI Out		%		
			MotTemp NTC		deg		
			Inv Temp		deg		
			Inv i2t		%		
			MP Output		%		
			Ctrl Mode		-		
			S/W Version		-		
			Run Time		-		
			Terminal In		-		
			Terminal Opt		-		
			Terminal Out		-		
			Run Status		-		
			Diameter <sup>2)</sup>		%		
			Line SPD CMD <sup>2)</sup>		%		
			Reel SPD <sup>2)</sup>		%		
			PhInOpenLvl		V		
DIS_02	-	User Display 2	Same as the range of 'DIS_01'		-	DC Bus Volt	Yes
DIS_03	-	User Display 3			-	Terminal In	Yes
DIS_04	-	Process PID Output Ref / FB	PIDOut		0.0%	-	-
			*xx.x%		0.0%		
DIS_05	-	Faulty Display	Faults		-	-	-
DIS_06	7106	User Group Display Setting	Usr Grp Disp		0 (Not Used) 1 (Dis+User Grp) 2 (Display ALL)	0 (Not Used)	Yes

Note)

1) It is effective only when you use Extended I/O (EXTN\_I/O).

2) It is displayed on WEB control Mode.

5.2. Digital DIO Group (DIO\_[][])

CODE NO.	Comm. Addr	CODE NAME	LCD DISPLAY	SETTING DATA			Adjustment During Run
				RANGE	UNIT	DEFAULT	
DIO_00	-	Jump for quick view	Jump Code	1 ~ 98	-	-	Yes
DIO_01	7201	Multi-function Input Terminal P1 definition	P1 define	0 (Not Used)	-	0 (Not Used)	No
				1 (Speed-L)			
				2 (Speed-M)			
				3 (Speed-H)			
				4 (Jog Speed)			
				5 (MOP Up)			
				6 (MOP Down)			
				7 (MOP Clear)			
				8 (MOP Save)			
				9 (Analog Hold)			
				10 (Main Drive)			
				11 (2nd Func)			
				12 (Xcel-L)			
				13 (Xcel-H)			
				14 (3-Wire)			
				15 (Ext Trip-B)			
				16 (Prohibit FWD)			
				17 (Prohibit REV)			
				18 (Proc PID Dis)			
				19 (Timer Input)			
				20 (SoftStrtCncl)			
				21 (ASR Gain Sel)			
				22 (ASR P/PI Sel)			
				23 (Flux Ref Sel)			
				24 (PreExcite)			
				25 (Spd/Trq Sel)			
26 (Use Max Trq)							
27 (Use Trq Bias)							
28 (AuxSpdEnable)							
30 (Battery Run) <sup>2)</sup>							
39 (Synch Disable) <sup>3)</sup>							
40 (Synch Hod) <sup>3)</sup>							
41 (LVT Disable)							
42 (Dia Hold) <sup>1)</sup>							
43 (Dia Preset) <sup>1)</sup>							
44 (CoreSize-L) <sup>1)</sup>							
45 (CoreSize-H) <sup>1)</sup>							

## 5. Function Code Table

CODE NO.	Comm. Addr	CODE NAME	LCD DISPLAY	SETTING DATA			Adjustment During Run	
				RANGE	UNIT	DEFAULT		
				46(TensionDisable) <sup>1)</sup>				
				47 (PI Gain Sel) <sup>1)</sup>				
				48 (PID ITerm Clr) <sup>1)</sup>				
				49 (Taper Disable) <sup>1)</sup>				
				50 (Stall Enable) <sup>1)</sup>				
				51 (Boost Enable) <sup>1)</sup>				
				52 (Quick Stop) <sup>1)</sup>				
				53 (Jog Web Fwd) <sup>1)</sup>				
				54 (Jog Web Rev) <sup>1)</sup>				
				55 (Under Wind) <sup>1)</sup>				
				56 (Unwinder) <sup>1)</sup>				
DIO_02	7202	Multi-function Input Terminal	P2 definition	P2 define	Same as the range of 'DIO_1'	-	0 (Not Used)	No
DIO_03	7203		P3 definition	P3 define		-	0 (Not Used)	No
DIO_04	7204		P4 definition	P4 define		-	0 (Not Used)	No
DIO_05	7205		P5 definition	P5 define		-	0 (Not Used)	No
DIO_06	7206		P6 definition	P6 define		-	0 (Not Used)	No
DIO_07	7207		P7 definition	P7 define		-	0 (Not Used)	No
DIO_08	-		Negative function of multi-function input terminal	Neg Func. In		0000000~ 1111111	bit	0000000
DIO_09	7209	Multi-function Input LPF time constant	Terminal LPF	0 ~ 2000	-	5	Yes	
DIO_10	-	Negative function of multi-function auxiliary output terminal	Neg Func. Out	00000~ 11111	bit	00000	No	
DIO_41	7229	Multi-function Auxiliary output	Definition of AX1	AX1 Define	0 (Not Used)	-	0 (Not Used)	Yes
					1 (INV Ready)			
					2 (Zero Spd Det)			
					3 (Spd Det.)			
					4 (Spd Det(ABS))			
					5 (Spd Arrival)			
					6 (Timer Out)			
					7 (LV Warn)			
					8 (Run)			
					9 (Regenerating)			
10 (Mot OH Warn)								

## 5. Function Code Table

CODE NO.	Comm. Addr	CODE NAME	LCD DISPLAY	SETTING DATA			Adjustment During Run	
				RANGE	UNIT	DEFAULT		
				11 (Inv OH Warn)				
				12 (Spd Agree)				
				13 (Trq Det.)				
				14 (Trq Lmt Det.)				
				15 (OverLoad)				
				16 (Stop)				
				17 (MC on/off)				
				18 (Steady)				
				19 (Brake Output)				
				25 (WEB Break) <sup>1)</sup>				
				26 (Up To Spd) <sup>1)</sup>				
				27 (False Core) <sup>1)</sup>				
DIO_42	722A	Definition of AX2	AX2 Define	Same as the range of 'DIO_41'	-	0 (Not Used)	Yes	
DIO_43	722B	Definition of OC1	OC1 Define		-	0 (Not Used)	Yes	
DIO_46	722E	Fault relay mode selection	Relay Mode	000 ~ 111	bit	011	Yes	
DIO_47	722F	Zero speed detection level	ZSD Level	0.0 ~ 480.0	rpm	10.0	Yes	
DIO_48	7230	Zero speed detection band	ZSD Band	0.1 ~ 10.0	%	0.5	Yes	
DIO_49	7231	Speed detection level	SD Level	-3600 ~ 3600	rpm	0	Yes	
DIO_50	7232	Speed detection band	SD Band	0.1 ~ 10.0	%	0.5	Yes	
DIO_51	7233	Speed arrival band	SA Band			0.5	Yes	
DIO_52	7234	Speed deviation band	SEQ Band			0.5	Yes	
DIO_53	7235	Torque detection level	TD Level	0.0 ~ 250.0	%	0.0	Yes	
DIO_54	7236	Torque detection band	TD Band	0.1 ~ 10.0	%	0.5	Yes	
DIO_55	7237	Timer On delay time	TimerOn Dly	0.1 ~ 3600.0	sec	0.1	Yes	
DIO_56	7238	Timer Off delay time	TimerOff Dly	0.1 ~ 3600.0	sec	0.1	Yes	
DIO_57	7239	Overload	Warning level	OL Level	30 ~ 250	%	150	Yes
DIO_58	723A		Warning time	OL Time	0 ~ 30	sec	10	Yes
DIO_59	723B		Trip selection	OLT Select	0 (No) 1 (Yes)	-	1 (Yes)	Yes
DIO_60	723C		Trip level	OLT Level	30 ~ 250	%	180	Yes
DIO_61	723D		Trip time	OLT Time	0 ~ 60	sec	60	Yes

## 5. Function Code Table

CODE NO.	Comm. Addr	CODE NAME	LCD DISPLAY	SETTING DATA			Adjustment During Run
				RANGE	UNIT	DEFAULT	
DIO_62	723E	Inverter overheat warning temp.	IH Warn Temp	50 ~ 85	deg	75	Yes
DIO_63	723F	Inverter overheat warning band	IH Warn Band	0 ~ 10	deg	5	Yes
DIO_64	7240	Motor overheat warning temp.	MH Warn Temp	75 ~ 130	deg	120	Yes
DIO_65	7241	Motor overheat warning band	MH Warn Band	0 ~ 10	deg	5	Yes
DIO_67	7243	MC ON delay time <sup>4)</sup>	MC Timer Off	100~50000	msec	1000	No
DIO_68	7244	MC OFF delay time <sup>4)</sup>	MC Timer Off	100~50000	msec	1000	No
DIO_95	725F	Inverter station address	Inv Number	1~250		1	No
DIO_96	7260	485 BaudRate	485 BaudRate	0 (1200)	bps	9600	No
				1 (2400)			
				2 (4800)			
				3 (9600)			
				4 (19200)			
5 (384000)							
DIO_97	7261	How to Run at Lost command	Lost Command	0 (None)	-	0 (None)	No
				1 (FreeRun)			
				2 (Stop)			
DIO_98	7262	Decision time when communication command is lost. <sup>4)</sup>	Comm. Timer	10~300	sec	10	No

Note)

1) Displayed WEB Control mode setting.

2) It can be set at 5.5 ~ 22 kW-2/4 class.

3) It will be displayed as CON\_02 sets to 'Synchro' when Synchronization option board is installed.

4) It will be displayed when the definition of multi-function output sets as 'MC On/Off'.

5) It will be displayed RS-485 communication option board is installed. Refer to the user manual for RS485/Modbus-RTU option board (iP5A/iV5).

## 5.3. Parameter group (PAR\_[])

CODE NO.	Comm. Addr	CODE NAME	LCD DISPLAY	SETTING DATA			Adjustment During Run	
				RANGE	UNIT	DEFAULT		
PAR_00	-	Jump for quick view	Jump Code	1 ~ 38	-	-	Yes	
PAR_01	7301	Initialize parameters	Para. init	0 (No) 1 (All Groups) 2 (DIS) 3 (DIO) 4 (PAR) 5 (FUN) 6 (CON) 7 (EXT) 8 (AIO) 9 (USR) 10 (2ND) 11 (E/L) 12 (SYN) 13 (WEB) 14 (SLS)	-	0 (No)	No	
PAR_02	-	Read parameters	Para. read	0(No) / 1(Yes)	-	0 (No)	No	
PAR_03	-	Write parameters	Para. write	0(No) / 1(Yes)	-	0 (No)	No	
PAR_04	-	Parameter write protection	Para. lock	0 ~ 255	-	0	Yes	
PAR_05	-	Password	Password	0 ~ 9999	-	0	Yes	
PAR_07	7307	Motor capacity selection	Motor select	0 (2.2) 1 (3.7) 2 (5.5) 3 (7.5) 4 (11.0) 5 (15.0) 6 (18.5) 7 (22.0) 8 (30.0) 9 (37.0) 10 (45.0) 11 (55.0) 12 (75.0) 13 (90.0) 14 (110.0) 15 (132.0) 16 (160.0) 17 (220.0) 18 (280.0) 19 (315.0) 20 (375.0) 21 (User Define) <sup>1)</sup>	kW	-	No	
PAR_08	7308	Motor cap. selection of USER	UserMotorSel	0.7 ~ 500.0	kW	5.5	No	
PAR_09	7309	Motor cooling type	Cooling Mtd	0 (Self-cool) 1 (Forced-cool)	-	1 (Forced cool)	Yes	
PAR_10	730A	Encoder	Pulse no.	Enc Pulse	360 ~ 4096	-	1024	No
PAR_11	730B		Direction setting	Enc Dir Set	0 (A Phase Lead) 1 (B Phase Lead)	-	0 (A Phase Lead)	No
PAR_12	730C		Error check enabling	Enc Err Chk	0 (No) / 1 (Yes)	-	1 (Yes)	No
PAR_13	730D		LPF time constant	Enc LPF	0 ~ 100	ms	1	Yes
PAR_14	730E		Error detection time	EncFaultTime	0.00 ~ 10.00	sec	0.00	No
PAR_15	730F		Error reference speed	EncFaultPerc	0.0 ~ 50.0	%	25.0	No

## 5. Function Code Table

CODE NO.	Comm. Addr	CODE NAME	LCD DISPLAY	SETTING DATA			Adjustment During Run	
				RANGE	UNIT	DEFAULT		
PAR_17	7311	Motor	Base speed	Base Speed	100.0 ~ 3600.0	rpm	1800.0	No
PAR_18	7312		Rated voltage	Rated Volt	120 ~ 560	V	-	No
PAR_19	7313		Number of poles	Pole number	2 ~ 12	-	4	Yes
PAR_20	7314		Efficiency	Efficiency	70.0 ~ 100.0	%	-	Yes
PAR_21	7315		Rated slip	Rated-Slip	10 ~ 250	rpm	-	Yes
PAR_22	7316		Rated current	Rated-Curr	1.0 ~ 1000.0	A	-	Yes
PAR_23	7317	Input power source selection	AC In Volt	170 ~ 230 320 ~ 480	V	-	No	
PAR_24	7318	Auto tuning type selection	Auto Tune Type	0 (Rotational) 1 (Standstill)	-	0 (Rotational)		
PAR_25	-	Auto tuning range setting <sup>2)</sup>	Auto Tuning	None ALL1/ALL2 Encoder Test Rs Tuning Lsigma Flux Curr Ls Tuning Tr Tuning Inertia Tuning <sup>4)</sup>	-	None	No	
PAR_26	731A	Tuning Torque	Tune Torque	10.0 ~ 100.0	%	70	Yes	
PAR_27	731B	Motor	Motor flux current	Flux-Curr	70% to 0.0 ~ PAR_22	A	-	Yes
PAR_28	731C		Motor time constant	Tr	30 ~ 3000	ms	-	Yes
PAR_29	731D		Leakage inductance	Ls	0.00 ~ 500.00	mH	-	Yes
PAR_30	731E		Leakage coefficient	Lsigma	0.00 ~ 100.00	mH	-	Yes
PAR_31	731F		Stator resistance	Rs	0.000 ~ 5.000	ohm	-	Yes
PAR_34	7322	Encoder pulse multiplication <sup>3)</sup>	Enc Scale	x1 / x16 / x32 / x64	-	x 1	No	
PAR_35	7323	Selection for motor inertia tuning	Inertia Tune	0 (No) / 1 (Yes)	-	0 (No)	No	
PAR_36	7324	Factor of motor inertia	Inertia	0.001 ~ 60.000	kg · m <sup>2</sup>	-	Yes	
PAR_37	7325	Acc./Dec. time of Inertia tuning	J Spd Time	0.500 ~ 10.000	sec	0.500	No	
PAR_38	7326	Inertia LPF	Inertia LPF	0.010 ~ 50.000	ms	0.100	No	

'Note' is continued on next page.



## 5. Function Code Table

Note)

- 1) When PAR\_07 is set to "User Define", PAR\_08 will be displayed.
- 2) If PAR\_24 (Auto-tuning type selection) is set to No.1 "Standstill", the order of display in PAR\_25 (Auto-tuning range setting) will be None → ALL1 → Rs Tuning → Lsigma → If/Tr/Ls Tune.
- 3) Caution: PAR\_33 (Enc Scale) Code is necessary only in the case of installation of SIN/COS Encoder option board, Don't modify the default value "X1" when not using SIN/COS Encoder board If you modify the value, the normal operation isn't possible. For any extra information in detail, refer to the option dedicated manual.
- 4) It will be displayed when PAR\_35(Selection for motor inertia tuning) sets as 'Yes'.

### 5.4. Function group (FUN\_[][])

CODE NO.	Comm. Addr	CODE NAME	LCD DISPLAY	SETTING DATA			Adjustment During Run
				RANGE	UNIT	DEFAULT	
FUN_00	-	Jump for quick view	Jump code	1 ~ 85	-	-	Yes
FUN_01	7401	RUN/STOP command source selection	Run/Stop Src	0 (Terminal 1) 1 (Terminal 2) 2 (Keypad) 3 (Option)	-	0 (Terminal 1)	No
FUN_02	7402	Speed setting source selection	Spd Ref Sel	0 (Analog) 1 (Keypad1) 2 (Keypad2) 3 (Option) 6 (Line SPD Ref) <sup>1)</sup> 7 (Line SPD Opt) <sup>1)</sup>	-	1 (Keypad1)	No
FUN_03	7403	Stop mode selection	Stop mode	0 (Decel) 1 (Free-run)	-	0 (Decel)	No
FUN_04	7404	Max. motor speed	Max Speed	400.0 ~ 3600.0	rpm	1800.0	No
FUN_05	7405	Min. motor speed	Min Speed <sup>2)</sup>	0.0 ~ 500.0		100.0	No
FUN_12	740C	Multi-step speed	0	0.0 ~ Max Speed		0.0	Yes
FUN_13	740D		1			0.0	Yes
FUN_14	740E		2			0.0	Yes
FUN_15	740F		3			0.0	Yes
FUN_16	7410		4			0.0	Yes
FUN_17	7411		5			0.0	Yes
FUN_18	7412		6			0.0	Yes
FUN_19	7413		7			0.0	Yes
FUN_20	7414	JOG speed	Jog Speed	100.0		Yes	
FUN_21	7415	Dwell Speed	Dwell Speed	100.0		No	

## 5. Function Code Table

CODE NO.	Comm. Addr	CODE NAME	LCD DISPLAY	SETTING DATA			Adjustment During Run
				RANGE	UNIT	DEFAULT	
FUN_22	7416	Dwell Time	Dwell Time	0.00 ~ 100.00	sec	0.00	No
FUN_33	7421	Acc./Dec. reference Speed	Acc/Dec Ref	0 (Max Speed) 1 (Ref Speed)	-	0 (Max Speed)	No
FUN_36	7424	S ratio 1 in acceleration start	Acc S Start	0.0 ~ 50.0	%	0.0	No
FUN_37	7425	S ratio 2 in acceleration start	Acc S End			0.0	No
FUN_38	7426	S ratio 1 in acceleration start	Dec S Start			0.0	No
FUN_39	7427	S ratio 2 in acceleration start	Dec S End			0.0	No
FUN_40	7428	Time scale of acc./dec. time	Time scale	0 (0.01 sec) 1 (0.1 sec)	-	0.0	No
FUN_41	7429	Acceleration time 1	Acc Time-1	0.00 ~ 6000.0	sec	2.00 <sup>2)</sup>	Yes
FUN_42	742A	Deceleration time 1	Dec Time-1			2.00 <sup>2)</sup>	Yes
FUN_43	742B	Acceleration time 2	Acc Time-2			3.00 <sup>2)</sup>	Yes
FUN_44	742C	Deceleration time 2	Dec Time-2			3.00 <sup>2)</sup>	Yes
FUN_45	742D	Acceleration time 3	Acc Time-3			4.00 <sup>2)</sup>	Yes
FUN_46	742E	Deceleration time 3	Dec Time-3			4.00 <sup>2)</sup>	Yes
FUN_47	742F	Acceleration time 4	Acc Time-4			5.00 <sup>2)</sup>	Yes
FUN_48	7430	Deceleration time 4	Dec Time-4			5.00 <sup>2)</sup>	Yes
FUN_49	7431	Selection about use of zero speed time	Use 0 Dec T	0 (No) / 1 (Yes)	-	0 (No)	Yes
FUN_51	7433	Dec.time of zero speed	0 Dec Time	0.00 ~ 6000.0	sec	0.00	Yes
FUN_52	7434	Dec. time of emergent stop	BX Time	0.0 ~ 6000.0	sec	0.0	Yes
FUN_53	7435	Initial excitation time of motor	PreExct Time	0 ~ 10000	ms	0	No
FUN_54	7436	Hold time	Hold Time	100 ~ 10000	ms	1000	No
FUN_55	7437	Electronic thermal Selection	ETH Select	0 (No) / 1 (Yes)	-	0 (No)	Yes
FUN_56	7438	Electronic thermal level for 1 minute	ETH 1 min	FUN_56 ~ 200	%	150	Yes
FUN_57	7439	Electronic thermal level for continuous	ETH Cont	50 ~ FUN_55 (Only available to 150%)	%	100	Yes

## 5. Function Code Table

CODE NO.	Comm. Addr	CODE NAME	LCD DISPLAY	SETTING DATA			Adjustment During Run	
				RANGE	UNIT	DEFAULT		
FUN_58	743A	Switching frequency select	PWM Freq	2.5 ~ 10.0 <sup>4)</sup>	kHz	According to inverter capacity	No	
FUN_59	743B	Power on Run selection	Power-on Run	0 (No) / 1 (Yes)	-	0 (No)	Yes	
FUN_60	743C	Restart after fault reset	RST Restart	0 (No) / 1 (Yes)	-	0 (No)	Yes	
FUN_61	743D	Number of auto restart try	Retry Number	0 ~ 10	-	0	Yes	
FUN_62	743E	Delay time before Auto restart	Retry Delay	0.0 ~ 60.0	sec	1.0	Yes	
FUN_63	743F	Wait time for Restart upon Stop	Restart Time <sup>5)</sup>	0.00 ~ 10.00	sec	0.00	No	
FUN_64	7440	Overspeed Detection Time	OverSpdLevel	100.0 ~ 130.0	%	120.0	No	
FUN_65	7441	Electronic thermal level for 1 minute	OverSpd Time	0.00 ~ 2.00	sec	0.00	No	
FUN_66	7442	Brake	Open Time <sup>6)</sup>	BKOpen Time	0.00 ~ 30.00	sec	0.00	No
FUN_67	7443		Open Speed <sup>6)</sup>	BKOpen Spd	0.0 ~ 500.0	rpm	0.0	No
FUN_68	7444		Open Current <sup>6)</sup>	Release Curr	0.0 ~ 150.0	%	20.0	No
FUN_69	7445		Close Time <sup>6)</sup>	BKClose Time	0.00 ~ 30.00	sec	0.00	No
FUN_70	7446		Close Speed <sup>6)</sup>	BKClose Spd	0.0 ~ 500.0	rpm	0.0	No
FUN_71	7447	Regeneration prevention	Run selection	RegenAvd Sel	0 (No) / 1 (Yes)	-	0 (No)	No
FUN_72	7448		Run voltage level <sup>7)</sup>	RegenAvd Lvl	600(300) ~ 800(400)	V	700(350)	No
FUN_73	7449		Speed limitation <sup>7)</sup>	CompFreq Lmt	0.0 ~ 500.0	rpm	100.0	No
FUN_74	744A		Speed P gain <sup>7)</sup>	RegenAvd P	0.0 ~ 300.0	%	50.0	Yes
FUN_75	744B		Speed I gain <sup>7)</sup>	RegenAvd I	20 ~ 30000	ms	500	Yes
FUN_76	744C	Speed in battery-operated mode <sup>8)</sup>	Batt. Speed	2.5 ~ 200.0	rpm	50.0	No	
FUN_77	744D	Battery input voltage <sup>8)</sup>	Batt. Volt	12 ~ PAR_18	V	48	No	
FUN_78	744E	Check of input phase-open	PhInOpenChk	0 (No) / 1 (Yes)	-	1 (Yes)	No	
FUN_79	7450	Check level of input phase-open	PhInOpenLvl	2.0 ~ 100.0	V	3.0	Yes	
FUN_80	7451	Check of output phase-open	PhOutOpenChk	0 (No) / 1 (Yes)	-	1 (Yes)	No	
FUN_81	7452	Max. auxiliary speed	AuxSpeedMax	0.0~500.0	rpm	10.0	Yes	

## 5. Function Code Table

CODE NO.	Comm. Addr	CODE NAME	LCD DISPLAY	SETTING DATA			Adjustment During Run
				RANGE	UNIT	DEFAULT	
FUN_82	7453	Calculation method of auxiliary speed	AuxSpeedType	0 ~ 1	-	0	No
FUN_83	7454	Acc. time of auxiliary speed	AuxAccTime	0.00 ~ 600.00	sec	2.00	No
FUN_84	7455	Dec. time of auxiliary speed	AuxDecTime	0.00 ~ 600.00	sec	2.00	No
FUN_85	7456	Absolute/Relative mode for auxiliary speed	AuxSpeedMode	0(Absolute) /1(Relative)	-	0 (Absolute)	No
FUN_86	7457	Speed in short floor operation mode	ShortFlr Spd	0.0~Max Speed	rpm	0.0	No
FUN_87	7458	Time of short floor operation mode	ShortFlrTime	0.00~100.00	sec	0.00	No
FUN_88	7459	Low Voltage2 Selection	LV2 Enable	0 (No) / 1 (Yes)	-	0 (No)	Yes
FUN_89	7460		Fast BX Sel	0 (No) / 1 (Yes)	-	0 (No)	Yes
FUN_90	7461		Neg BX Sel	0 (No) / 1 (Yes)	-	0 (No)	Yes
FUN_91	7462		RunStop Src2	0 (Terminal 1) 1 (Terminal 2) 2 (Keypad) 3 (Option) 4 (Int485)	-	2 (Keypad)	No
FUN_92	7463		Spd Ref Sel2	0 (Terminal 1) 1 (Terminal 2) 2 (Keypad) 3 (Option) 4 (Int485)	-	1 (Keypad1)	No
FUN_93	7464		Trq Ref Sel2	0 (Terminal 1) 1 (Terminal 2) 2 (Keypad) 3 (Option) 4 (Int485)	-	1 (Keypad1)	No

Note)

- 1) It will be displayed when WEB control mode is set.
- 2) It will be displayed when CON\_01 is set to Sensorless.
- 3) A default value of a time of acceleration and deceleration is different from the setting capacity of inverter.
- 4) Minimum/Maximum values are different from the capacity of inverter.

## 5. Function Code Table

- 5) It will be displayed when FUN\_03 (Stop method) is set to 'Free-run'.
- 6) It will be displayed when the definition of DIO\_41 to DIO\_43 (Auxiliary output terminal of multi-funtion) is set to 'Brake Output'.
- 7) It will be displayed when FUN\_71 is set to 'Yes'.
- 8) It can set for only 5.5 ~ 22 kW/2/4 products in case 'Battery Run' of multi-function input terminal (P1 ~ P&) is turned On.

### 5.5. Control group (CON\_[][])

CODE NO.	Comm. Addr.	CODE NAME	LCD DISPLAY	SETTING DATA			Adjustment During Run	
				RANGE	UNIT	DEFAULT		
CON_00	-	Jump for quick view	Jump Code	1 ~ 80	-	-	Yes	
CON_01	7501	Control mode setting	Control Mode	1 (Speed) 2 (Torque) 3 (Sensorless)	-	1 (Speed)	No	
CON_02	-	Application mode setting	Application	General Vect Elevator <sup>1)</sup> Synchro <sup>2)</sup> WEB Control	-	General Vect	No	
CON_03	7503	ASR	P Gain 1	ASR P Gain1	0.1 ~ 200.0	%	50.0	Yes
CON_04	7504		I Gain 1	ASR I Gain1	0 ~ 50000	ms	300	Yes
CON_05	7505		LPF time constant 1	ASR LPF1	0 ~ 20000	ms	0	Yes
CON_06	7506		P Gain 2	ASR P Gain2	0.1 ~ 200.0	%	5.0	Yes
CON_07	7507		I Gain 2	ASR I Gain2	0 ~ 50000	ms	3000	Yes
CON_08	7508		LPF time constant 2	ASR LPF2	0 ~ 20000	ms	0	Yes
CON_09	7509		Ramp time for ASR gain	ASR RAMP	10 ~ 10000	ms	1000	Yes
CON_10	750A		Target Speed	ASR TarSpd	0.0 ~ 3600.0	rpm	0.0	No

## 5. Function Code Table

CODE NO.	Comm. Addr.	CODE NAME	LCD DISPLAY	SETTING DATA			Adjustment During Run	
				RANGE	UNIT	DEFAULT		
			after ASR gain switch-over					
CON_11	750B	Process ID	Reference (Loader)	Proc PID Ref	-100.0 ~ 100.0	%	0.0	Yes
CON_12	750C		Ramp time	PID Ramp	0.00 ~ 600.0	sec	0.00	No
CON_14	750E		P gain	Proc PID Kp	0.0 ~ 999.9	%	0.0	Yes
CON_15	750F		I gain	Proc PID Ki	0.0 ~ 100.0	%	0.0	Yes
CON_16	7510		D gain	PROC PID Kd	0.0 ~ 100.0	%	0.0	Yes
CON_17	7511		Positive limit	Proc Pos Lmt	-100.0 ~ 100.0	%	100	Yes
CON_18	7512		Negative limit	Proc Neg Lmt	-100.0 ~ 100.0	%	100	Yes
CON_19	7513		Output LPF time constant	Proc Out LPF	0 ~ 500	ms	0	Yes
CON_20	7514		Output gain	Proc OutGain	-250.0 ~ 250.0	%	0.0	Yes
CON_21	7515		Type selection	Proc PID Src	0 (Base Speed) 1 (Ref Speed) 2 (SpeedSet)		0 (Base Speed)	No
CON_22	7516		Speed Set setting <sup>3)</sup>	PID SpeedSet	1.00 ~ FUN_04	rpm	100.0	No
CON_23	7517		Output Enable	Proc PID Enb	0 (Disable) 1 (Enable) 2 (Terminal)	-	0 (Disable)	No
CON_24	7518		Hold Time	PIDHoldTime	0 ~ 10000	ms	1000	No
CON_25	7519		Draw quantity	Draw %	-100.0 ~ 100.0	%	0.0	Yes
CON_26	751A		Droop	Control quantity	Droop %	0.0 ~ 100.0	%	0.0
CON_27	751B	Base speed		Droop Src	0(Base Spd)/ 1(Ref Spd)		1 (Ref Speed)	No
CON_28	751C	Ramp time		Droop Time	0.00 ~ 600.0	sec	2.00	Yes
CON_29	751D	Minimum speed		Droop MinSpd	0.0 ~ 3600.0	rpm	0.0	Yes
CON_30	751E	Minimum torque		Droop MinTrq	0.0 ~ 100.0	%	0.0	Yes
CON_31	751F	Torque	Reference source selection	Trq Ref Src	0 (None) 1 (Analog) 2 (Keypad) 3 (Option)	-	0 (None)	No
CON_32	7520		Reference (keypad)	Torque Ref	-180.0 ~ 180.0	%	0.0	Yes
CON_33	7521		Limit source selection	Trq Lmt Src	0 (Kpd Kpd Kpd) 1 (Kpd Kpd Ax) 2 (Kpd Ax Kpd) 3 (Kpd Ax Ax) 4 (Ax Kpd Kpd)	-	0 (Kpd Kpd Kpd)	No

## 5. Function Code Table

CODE NO.	Comm. Addr.	CODE NAME	LCD DISPLAY	SETTING DATA			Adjustment During Run	
				RANGE	UNIT	DEFAULT		
				5 (Ax Kpd Ax) 6 (Ax Ax Kpd) 7 (Ax Ax Ax) 8 (Opt Opt Opt)				
CON_34	7522	Limit in forward run	Pos Trq Lmt	0.0 ~ 250.0	%	150.0	Yes	
CON_35	7523	Limit in reverse run	Neg Trq Lmt			150.0	Yes	
CON_36	7524	Limit in regeneration	Reg Trq Lmt			150.0	Yes	
CON_37	7525	Bias source selection	Trq Bias Src	0 (None) 1 (Analog) 2 (Keypad) 3 (Option)	-	0 (None)	No	
CON_38	7526	Bias quantity	Trq Bias	-150.0 ~ 150.0	%	0.0	Yes	
CON_39	7527	Bias feedforward	Trq Bias FF			0.0	Yes	
CON_40	7528	Balance quantity	Trq Balance	0.0 ~ 100.0	%	50.0	Yes	
CON_54	7536	Speed Search selection	Speed Search	0000~ 1111 (Bit setting)	-	0100	No	
CON_75	754B	Speed Search	Speed Search time <sup>4)</sup>	SS Time	10 ~ 60000	ms	300	No
CON_76	754C		Speed Search P gain <sup>4)</sup>	SS P Gain	1.0 ~ 300.0	%	100.0	Yes
CON_77	754D		Speed Search I gain <sup>4)</sup>	SS I Gain	1.0 ~ 300.0	%	100.0	Yes
CON_78	754E		Speed Search LPF <sup>4)</sup>	SS LPF	0.1 ~ 300.0	ms	33.3	Yes
CON_79	754F	Speed limit of Speed/Torque switch-over	Spd Lmt Src	0.1 ~ Max Speed	rpm	1800.0	No	
CON_80	7550	Speed bias of speed/torque	SpdLmtBias	100.0 ~ Max Speed	rpm	100.0	No	

Note)

- 1) It will be displayed only when the E/L\_IO board is installed.
- 2) It will be displayed only when the SYNC\_IO board is installed.
- 3) It will be displayed when CON\_21 (Process PID type) is set to SpeedSet.
- 4) It will be displayed when CON\_01 is set to Sensorless.

## 5. Function Code Table

### 5.6. User group (USR\_[][])

CODE NO.	Comm. Addr.	CODE NAME	LCD DISPLAY	SETTING DATA			Adjustment During Run
				RANGE	UNIT	DEFAULT	
USR_00	-	Select Code number	Jump Code	1 ~ 67	-	-	Yes
USR_01	-	Initialize to the initial value adequate to the application	Macro Init	User Define E/L	-	User Define	No
USR_02	-	User data save	User Save	No / Yes	-	No	No
USR_03	-	Recall saved User Data.	User Recall	No / Yes	--	No	No
USR_04	-	User Group Data	User Grp	-	-	-	No



## 5.7. Second motor Group (2nd\_[][])

CODE NO.	Comm. Addr.	CODE NAME	LCD DISPLAY	SETTING DATA			Adjustment During Run	
				RANGE	UNIT	DEFAULT		
2nd_00	-	Jump for quick view	Jump Code	1 ~ 37	-	-	Yes	
2nd_01	7801	2nd Motor	Control mode setting	2nd Ctl Mode	1 (Speed) 2 (Torque)	-	1 (Speed)	No
2nd_02	7802		Max. speed	2nd Max Spd	400.0 ~ 3600.0	rpm	1800.0	No
2nd_04	7804		Multi-step speed 0	2nd Spd 0	0.0 ~ 2nd_02	rpm	0.0	Yes
2nd_05	7805		S ratio 1 in acceleration start	2nd Acc S St	0.0 ~ 50.0	%	0.0	No
2nd_06	7806		S ratio 2 in acceleration end	2nd Acc S Ed			0.0	No
2nd_07	7807		S ratio 1 in deceleration start	2nd Dec S St			0.0	No
2nd_08	7808		S ratio 2 in deceleration end	2nd Dec S Ed			0.0	No
2nd_09	7809		Acc./Dec. time scale	Time scale 2	0 (0.01 sec) 1 (0.1 sec)	-	0 (0.01 sec)	No
2nd_10	780A		Acceleration time	2nd Acc time	0.00 ~ 6000.0	sec	10.00	Yes
2nd_11	780B		Deceleration time	2nd Dec time			10.00	Yes
2nd_12	780C		Cooling method	2nd Cool Mtd	0 (Self-cool) 1 (Forced-cool)	-	0 (Self-cool)	Yes
2nd_13	780D		Encoder pulse no.	2nd Enc #	360 ~ 4096	-	1024	No
2nd_14	780E		Encoder direction setting	2nd Enc Dir	0 (A Phase Lead) 1 (B Phase Lead)	-	0 (A Phase Lead)	No
2nd_15	780F		Encoder error check enable	2nd Enc chk	0 (No) 1 (Yes)	-	1 (Yes)	No
2nd_16	7810		Encoder LPF time constant	2nd Enc LPF	0 ~ 100	ms	1	Yes
2nd_18	7812		Base speed	2nd BaseSpd	300.0 ~ 3600.0	rpm	1800.0	No
2nd_19	7813		Capacity selection	Motor select	Refer to 'PAR_07'	kW	2 (5.5)	No
2nd_20	7814		User defined motor selection	UserMotorSel <sup>1)</sup>	0.7 ~ 500	kW	5.5	No
2nd_21	7815		Rated voltage	2nd R-Volt	120 ~ 560	V	-	No
2nd_22	7816		Number of poles	2nd Pole #	2 ~ 12	-	4	No
2nd_23	7817		Efficiency	2nd Mot Eff.	70 ~ 100	%	-	Yes
2nd_24	7818		Rated slip	2nd R-Slip	10 ~ 250	rpm	-	Yes
2nd_25	7819		Rated current	2nd R-Curr	1.0 ~ 1000.0	A	-	Yes
2nd_26	781A		Flux current	2nd Flx Cur	0.0 ~ 70% of 2nd_25	A	-	Yes
2nd_27	781B		Motor time constant	2nd Mot Tr	30 ~ 3000	ms	-	Yes
2nd_28	781C		Leakage inductance	2nd Mot Ls	0.00 ~ 500.00	mH	-	Yes

## 5. Function Code Table

CODE NO.	Comm. Addr.	CODE NAME	LCD DISPLAY	SETTING DATA			Adjustment During Run
				RANGE	UNIT	DEFAULT	
2nd_29	781D	Leakage coefficient Stator resistance Electronic thermal level for 1 minute <sup>2)</sup> Electronic thermal continuous level <sup>2)</sup>	2nd Mot sLs	0.00 ~ 300.00	mH	-	Yes
2nd_30	781E		2nd Mot Rs	0.000 ~ 15.000	ohm	-	Yes
2nd_35	7823		2nd ETH 1min	100 ~ 150	%	150	Yes
2nd_36	7824		2nd ETH cont	50 ~ 2nd_35	%	100	Yes
2nd_37	7825	Inertia coefficient	Inertia	0.001 ~ 60.000	kg · m <sup>2</sup>	-	Yes

1) When 2nd\_19 is set to "User Define", 2nd\_20 will be displayed.

2) It will be displayed when FUN\_55 ETH Select is set to 'Yes'.

### 5.8 Option Group (EXT\_[][])

CODE NO.	Comm. Addr.	CODE NAME	LCD DISPLAY	SETTING DATA			Adjustment During Run
				RANGE	UNIT	DEFAULT	
EXT_00	-	Function code selection	Jump Code	1 ~ 99	-		Yes
EXT_01	7601	Mounted option board type	Opt B/D	0 (None) 1 (DeviceNet) 2 (Synchro) 3 (PLC-GF) 4 (PROFIBUS) 6 (RS485) <sup>1)</sup> 7 (MODBUS)	-	0 (None)	No
EXT_02	7602	Mounted option board version	Opt Version	1.0 ~	Ver -.-		No
EXT_03	7603	Station address for the communication with PLC	Station ID <sup>2)</sup>	0 ~ 63	-	1	Yes
EXT_04	7604	DeviceNet baud rate	Baud Rate <sup>3)</sup>	0 (125)/1 (250)/2 (500)	kbps	0 (125)	-
EXT_05	7605	DeviceNet MAC ID	MAC ID <sup>3)</sup>	0 ~ 63	-	63	-
EXT_06	7606	Read object setting for DeviceNet	Out Instance <sup>3)</sup>	0 (20)/ 1 (21) 2 (100)/ 3 (101)	-	0 (20)	-
EXT_07	7607	Write object settinf for DeviceNet	In Instance <sup>3)</sup>	0 (70)/ 1 (71) 2 (110)/ 3 (111)	-	0 (70)	-
EXT_09	7609	Profibus MAC ID	Profi MAC ID	1 ~ 127	-	1	Yes
EXT_10	760A	Number of option output	Output Num	0 ~ 8 <sup>5)</sup>	-	3	Yes
EXT_11	760B	Option output 1	Output 1 <sup>5)</sup>	0000 ~ FFFF	HEX	0020	Yes
EXT_12	760C	Option output 2	Output 2 <sup>5)</sup>	0000 ~ FFFF	HEX	000E	Yes
EXT_13	760D	Option output 3	Output 3 <sup>5)</sup>	0000 ~ FFFF	HEX	000F	Yes
EXT_14	760E	Option output 4	Output 4 <sup>5)</sup>	0000 ~ FFFF	HEX	000A	Yes
EXT_15	760F	Option output 5	Output 5 <sup>5)</sup>	0000 ~ FFFF	HEX	0000	Yes
EXT_16	7610	Option output 6	Output 6 <sup>5)</sup>	0000 ~ FFFF	HEX	0000	Yes
EXT_17	7611	Option output 7	Output 7 <sup>5)</sup>	0000 ~ FFFF	HEX	0000	Yes

## 5. Function Code Table

CODE NO.	Comm. Addr.	CODE NAME	LCD DISPLAY	SETTING DATA			Adjustment During Run
				RANGE	UNIT	DEFAULT	
EXT_18	7612	Option output 8	Output 8 <sup>5)</sup>	0000 ~ FFFF	HEX	0000	Yes
EXT_19	7613	Number of option input	Input Num	0 ~ 8 <sup>6)</sup>	-	2	Yes
EXT_20	7614	Option input 1	Input 1 <sup>6)</sup>	0000 ~ FFFF	HEX	0502	No
EXT_21	7615	Option input 2	Input 2 <sup>6)</sup>	0000 ~ FFFF	HEX	0500	No
EXT_22	7616	Option input 3	Input 3 <sup>6)</sup>	0000 ~ FFFF	HEX	0000	No
EXT_23	7617	Option input 4	Input 4 <sup>6)</sup>	0000 ~ FFFF	HEX	0000	No
EXT_24	7618	Option input 5	Input 5 <sup>6)</sup>	0000 ~ FFFF	HEX	0000	No
EXT_25	7619	Option input 6	Input 6 <sup>6)</sup>	0000 ~ FFFF	HEX	0000	No
EXT_26	761A	Option input 7	Input 7 <sup>6)</sup>	0000 ~ FFFF	HEX	0000	No
EXT_27	761B	Option input 8	Input 8 <sup>6)</sup>	0000 ~ FFFF	HEX	0000	No
EXT_30	761E	485 communication mode	Parity/Stop <sup>1)</sup>	0 (8None/1Stop) 1 (8None/2Stop) 2 (8Even/1Stop) 3 (8Odd/1Stop)	-	0 (8None/ 1Stop)	Yes
EXT_31	761F	Delay time of 485 communication response	Delay Time <sup>1)</sup>	2 ~ 1000	ms	5	Yes
EXT_32	7620	Station address for built-in 485	Int485 St ID	1 ~ 250	-	2	Yes
EXT_33	7621	Built-in 485 baudrate	Int485 Baud	0 (1200 bps) 1 (2400 bps) 2 (4800 bps) 3 (9600 bps) 4 (19200 bps) 5 (38400 bps)	-	3 (9600 bps)	Yes
EXT_34	7622	Built-in 485 communication mode	Int485 Mode	0 (8None/1Stop) 1 (8None/2Stop) 2 (8Even/1Stop) 3 (8Odd/1Stop)	-	-	Yes
EXT_35	7623	Delay time for built-in 485 communication response	Int485 Delay	2 ~ 1000	-	0 (None)	Yes
EXT_36	7624	Run method when the command of built-in 485 is lost.	Int485 LostC	0 (None) 1 (FreeRun) 2 (Stop)	-	-	Yes
EXT_37	7625	Decision time for losing the command of built-in 485	Int485 LostT	1.0 ~ 30.0	-	-	Yes
EXT_98	7662	Profibus data swap Selection	SWAP Sel	0 (No) / 1 (Yes)	-	0 (No)	No
EXT_99	7663	Update for communication parameter changes	Comm UpDate <sup>4)</sup>	0 (No) / 1 (Yes)	-	0 (No)	No

- 1) It will be displayed when RS-485 communication option board is installed.
- 2) It will be displayed when PLC-GF communication option board is installed.
- 3) It will be displayed when DeviceNet communication option board is installed.
- 4) It will be displayed when Profibus communication option board is installed.
- 5) From EXT\_11 to EXT\_18 (Option output) are displayed according to the number from EXT\_11.
- 6) From EXT\_20 to EXT\_27 (Option input) are displayed according to the number from EXT\_19.

Refer to the appropriate option manual.

## 5. Function Code Table

### 5.9 Analog AIO Group (AIO\_[][])

CODE NO.	Comm. Addr.	CODE NAME	LCD DISPLAY	SETTING DATA			Adjustment During Run			
				RANGE	UNIT	DEFAULT				
AIO_00	-	Select code number	Jump Code	1 ~ 83	-	-	Yes			
AIO_01	7701	Multi-function Analog Input Ai1	Multi-function Analog input Ai1 definition	Ai1 Define	0 (Not Used) 1 (Speed Ref) 2 (Proc PID Ref) 3 (Proc PID F/B) 4 (Draw Ref) 5 (Torque Ref) 6 (Flux Ref) 7 (Torque Bias) 8 (Torque Limit) 9 (Line SPD Ref) <sup>1)</sup> 10 (Tension Ref) <sup>1)</sup> 11 (Dancer Ref) <sup>1)</sup> 12 (Taper Ref) <sup>1)</sup> 13 (Tension F/B) <sup>1)</sup> 14 (Diameter) <sup>1)</sup> 15 (Diam Preset) <sup>1)</sup>	-	0 (Not Used)	No		
AIO_02	7702				Source definition	Ai1 Source	0 (-10 → 10V) 1 (10 → -10V) 2 (0 → 10V) 3 (10 → 0V) 4 (0 → 20mA) 5 (20 → 0mA)	-	0 (-10 → 10V)	No
AIO_03	7703				Minimum Voltage	Ai1 In X1	0.00 ~ Ai1 In X2	%	0.00	Yes
AIO_04	7704				Minimum Voltage Bias	Ai1 Out Y1	-10.00 ~ Ai1 Out Y2	%	0.00	Yes
AIO_05	7705				Maximum Voltage	Ai1 In X2	0.00 ~ 100.00	%	100.00	Yes
AIO_06	7706				Maximum Voltage Gain	Ai1 Out Y2	0.00 ~ 250.00	%	100.00	Yes
AIO_07	7707				Minimum Voltage	Ai1 -In X1	Ai1 -In X2 ~ 0.00	%	0.00	Yes
AIO_08	7708				Minimum Voltage Bias	Ai1 -Out Y1	Ai1 -Out Y2 ~ 10.00	%	10.00	Yes
AIO_09	7709				Maximum Voltage	Ai1 -In X2	-100.00 ~ 0.00	%	-100.00	Yes
AIO_10	770A				Maximum Voltage Gain	Ai1 -Out Y2	-250.00 ~ 0.00	%	-100.00	Yes
AIO_11	770B				LPF time constant	Ai1 LPF	0 ~ 2000	ms	-	-
AIO_12	770C				Command loss Criterion select	Ai1 Wbroken	0 (None) 1 (Half of x1) 2 (Below x1)	-	0 (None)	No

Note)

1) Displayed only when WEB mode setting.

## 5. Function Code Table

CODE NO.	Comm. Addr.	CODE NAME	LCD DISPLAY	SETTING DATA			Adjustment During Run	
				RANGE	UNIT	DEFAULT		
AIO_13	770D	Multi-function Analog Input Ai2	Multi-function Analog input Ai2 Definition	Ai2 Define	Refer to AIO_01~12			
AIO_14	770E		Source definition	Ai2 Source				
AIO_15	770F		Minimum Voltage	Ai2 In X1				
AIO_16	7710		Minimum Voltage Bias	Ai2 Out Y1				
AIO_17	7711		Maximum Voltage	Ai2 In X2				
AIO_18	7712		Maximum Voltage Gain	Ai2 Out Y2				
AIO_19	7713		Minimum Voltage	Ai2 -In X1				
AIO_20	7714		Minimum Voltage Bias	Ai2 -Out Y1				
AIO_21	7715		Maximum Voltage	Ai2 -In X2				
AIO_22	7716		Maximum Voltage Gain	Ai2 -Out Y2				
AIO_23	7717		LPF time constant	Ai2 LPF				
AIO_24	7718		Loss command Criterion select	Ai2 Wbroken				
AIO_25	7719		Multi-function Analog Input Ai3	Multi-function Analog input Ai3 Definition				Ai3 Define
AIO_26	771A	Source Definition		Ai3 Source	0 (-10 → 10V) 1 (10 → -10V) 2 (0 → 10V) 3 (10 → 0V)	-	0 (-10 → 10V)	No
AIO_27	771B	Minimum Voltage		Ai3 In X1	Refer to AIO_03~12			
AIO_28	771C	Minimum Voltage Bias		Ai3 Out Y1				
AIO_29	771D	Maximum Voltage		Ai3 In X2				
AIO_30	771E	Maximum Voltage Gain		Ai3 Out Y2				
AIO_31	771F	Minimum Voltage		Ai3 -In X1				
AIO_32	7720	Minimum Voltage Bias		Ai3 -Out Y1				
AIO_33	7721	Maximum Voltage		Ai3 -In X2				
AIO_34	7722	Maximum Voltage Gain		Ai3-Out Y2				
AIO_35	7723	Input LPF time constant		Ai3 LPF				
AIO_36	7724	Multi-function Analog input Command loss criterion select		Ai3 Wbroken				

## 5. Function Code Table

CODE NO.	Comm. Addr.	Code Name	LCD DISPLAY	SETTING DATA			Adjustment During Run	
				RANGE	UNIT	DEFAULT		
AIO_37	7725	Multi-function Analog Input Ai4	Multi-function Analog input Ai4 Definition <sup>1)</sup>	Ai4 Define				
AIO_38	7726		Source Definition <sup>1)</sup>	Ai4 Source				
AIO_39	7727		Minimum Voltage <sup>1)</sup>	Ai4 In X1				
AIO_40	7728		Minimum Voltage Bias <sup>1)</sup>	Ai4 Out Y1				
AIO_41	7729		Maximum Voltage <sup>1)</sup>	Ai4 In X2				
AIO_42	772A		Maximum Voltage Gain <sup>1)</sup>	Ai4 Out Y2				
AIO_43	772B		Minimum Voltage <sup>1)</sup>	Ai4 -In X1				
AIO_44	772C		Minimum Voltage Bias <sup>1)</sup>	Ai4 -Out Y1				
AIO_45	772D		Maximum Voltage <sup>1)</sup>	Ai4 -In X2				
AIO_46	772E		Maximum Voltage Gain <sup>1)</sup>	Ai4 -Out Y2				
AIO_47	772F		Output LPF time constant <sup>1)</sup>	Ai4 LPF				
AIO_48	7730		Command loss criterion select <sup>1)</sup>	Ai4 Wbroken				
AIO_49	7731		Multi-function Analog Input Ai5	Multi-function Analog input Ai5 Definition <sup>1)</sup>				Ai5 Define
AIO_50	7732	Source Definition <sup>1)</sup>		Ai5 Source	0 (-10 → 10V) 1 (10 → -10V) 2 (0 → 10V) 3 (10 → 0V)	-	0 (-10 → 10V)	No
AIO_51	7733	Minimum Voltage <sup>1)</sup>		Ai5 In X1	Refer to AIO_03~12.			
AIO_52	7734	Minimum Voltage Bias <sup>1)</sup>		Ai5 Out Y1				
AIO_53	7735	Maximum Voltage <sup>1)</sup>		Ai5 In X2				
AIO_54	7736	Maximum Voltage Gain <sup>1)</sup>		Ai5 Out Y2				
AIO_55	7737	Minimum Voltage <sup>1)</sup>		Ai5 -In X1				
AIO_56	7738	Minimum Voltage Bias <sup>1)</sup>		Ai5 -Out Y1				
AIO_57	7739	Maximum Voltage <sup>1)</sup>		Ai5 -In X2				
AIO_58	773A	Maximum Voltage Gain <sup>1)</sup>		Ai5 -Out Y2				
AIO_59	773B	Input LPF time constant <sup>1)</sup>		Ai5 LPF				
AIO_60	773C	Command loss criterion select <sup>1)</sup>	Ai5 Wbroken					

## 5. Function Code Table

CODE NO.	Comm. Addr	CODE NAME	LCD DISPLAY	SETTING DATA			Adjustment During Run	
				RANGE	UNIT	DEFAULT		
AIO_73	7749	Multi-function Analog input command loss time	Time out	0.1 ~ 120.0	sec	1.0	No	
AIO_74	774A	Multi-function analog Output AO1 Definition	AO1 Define	0 (Not Used) 1 (Ai1 Value) 2 (Ai2 Value) 3 (Ai3 Value) 4 (Ai4 Value) <sup>2)</sup> 5 (Ai5 Value) <sup>2)</sup> 7 (PreRamp Ref) 8 (PostRamp Ref) 9 (ASR Inp Ref) 11 (Motor Speed) 12 (Motor SpdEst) <sup>3)</sup> 13 (Speed Dev) 14 (ASR Out) 15 Torque Bias 16 (PosTrq Limit) 17 (NegTrq Limit) 18 (RegTrq Limit) 19 (Torque Ref) 20 (IqeRef) 21 (Iqe) 22 (Flux Ref) 23 (IdeRef) 24 (Ide) 25 (ACR_Q Out) 26 (ACR_D Out) 27 (VdeRef) 28 (VqeRef) 29(Out Amps RMS) 30 (Out Volt RMS) 31 (Power) 32 (DC Bus Volt) 33 (Proc PI Ref) 34 (PROC PI F/B) 35 (Proc PI Out) 36 (Line Speed) <sup>1)</sup> 37 (Tension Out) <sup>1)</sup> 38 (Diameter) <sup>1)</sup> 39 (MotNTC Temp) 40 (Inv Temp) 41 (Inv i2t)	-	0 (Not Used)	No	

## 5. Function Code Table

CODE NO.	Comm. Addr.	CODE NAME	LCD DISPLAY	Setting Data			Adjustment During Run
				Range	Unit	Default	
AIO_75	774B	Source Definition	AO1 Source	0 (-10 → 10V) 1 (10 → -10V) 2 (0 → 10V) 3 (10 → 0V)	-	0 (-10 → 10V)	No
AIO_76	774C	Bias	AO1 Bias	-100.0 ~ AIO_77	%	0.0	No
AIO_77	774D	Gain	AO1 Gain	0.0 ~ 500.0	%	100.0	No
AIO_78	774E	Bias	AO1 Bias	AIO_79 ~ 0.0	%	0.0	Yes
AIO_79	774F	Gain	AO1 Gain	0.0 ~ -500.0	%	-100.0	Yes
AIO_80	7750	Absolute value setting	AO1 ABS	0 (No) / 1 (Yes)	-	0 (No)	No
AIO_81	7751	Definition	AO2 Define	Refer to AIO_74~78			
AIO_82	7752	Source Definition	AO2 Source				
AIO_83	7753	Bias	AO2 Bias				
AIO_84	7754	Gain	AO2 Gain				
AIO_85	7755	Bias	AO2 Bias				
AIO_86	7756	Gain	AO2 Gain				
AIO_87	7757	Absolute value setting	AO2 ABS				

Note)

- 1) Displayed only when WEB mode setting.
- 2) It is available when Extension I/O (EXTN\_I/O) is applied.
- 3) It will be displayed when CON\_01 is set to 'Sensorless'.



5.10 Sensorless control Group (SLS\_[])<sup>1)</sup>

CODE NO.	Comm. Addr.	CODE NAME	LCD DISPLAY	Setting Data			Adjustment During Run
				Range	Unit	Default	
SLS_00	-	Function code selection	Jump Code	1 ~ 23			Yes
SLS_01	7D01	Flux estimation time with sensorless control	Flux BD Time	100 ~ 60000	ms	500	Yes
SLS_02	7D02	P gain for flux estimation	FlxEst PGain	0.1 ~ 999.9	%	100.0	Yes
SLS_03	7D03	I gain for flux estimation	FlxEst IGain	0.0 ~ 999.9	%	100.0	Yes
SLS_04	7D04	cut-off frequency for sensorless ASR	ASR Cut-Off	1.0 ~ 600.0		20.0	Yes
SLS_05	7D05	Sensorless ASR P gain 1	ASR P Gain1	0.1 ~ 999.9	%	100.0	Yes
SLS_06	7D06	Sensorless ASR I gain 1	ASR I Gain1	0.1 ~ 999.9	%	100.0	Yes
SLS_07	7D07	Sensorless ASR LPF 1	ASR LPF1	0 ~ 20000	ms	0	Yes
SLS_08	7D08	Sensorless ASR P gain 2	ASR P Gain2	0.1 ~ 999.9	%	50.0	Yes
SLS_09	7D09	Sensorless ASR I gain 2	ASR I Gain2	0.1 ~ 999.9	%	50.0	Yes
SLS_10	7D0A	Sensorless ASR LPF 2	ASR LPF2	0 ~ 20000	ms	0	Yes
SLS_11	7D0B	Switch-over ramp for sensorless ASR	ASR RAMP	10 ~ 10000	ms	1000	Yes
SLS_12	7D0C	Sensorless ASR target speed	ASR TarSpd	0.0 ~ 3600.0	rpm	0.0	No
SLS_13	7D0D	Sensorless P gain	SpdEst PGain	0.1 ~ 999.9	%	100.0	Yes
SLS_14	7D0E	Sensorless I gain	SpdEst IGain	0.1 ~ 999.9	%	100.0	Yes
SLS_15	7D0F	Cut-off frequency for sensorless ACR	ACR Cut-off	10.0 ~ 3000.0		1200.0	Yes
SLS_16	7D10	Regeneration avoidance selection	ZeroAvd Sel	0 (No) / 1 (Yes)		1 (Yes)	No
SLS_17	7D11	P gain of sensed speed controller	SensoredKp	0 ~ 10.0000		0.0000	No
SLS_18	7D12	I gain of sensed speed controller	SensoredKi	0 ~ 10.0000		0.0000	No
SLS_19	7D13	P gain of sensorless speed controller	SensorlessKp	0 ~ 10.0000		0.0000	No
SLS_20	7D14	I gain of sensorless speed controller	SensorlessKi	0 ~ 10.0000		0.0000	No
SLS_21	7D15	Command of flux estimation	FluxEst Ref	0.0000 ~ 6.5535		0.0000	No
SLS_22	7D16	Feedback of flux estimation	FluxEst Fbk	0.0000 ~ 6.5535		0.0000	No
SLS_23	7D17	Rs scale	Rs Scale	100.0 ~ 200.0	%	120.0	Yes

1) It will be displayed when CON\_01 is set to Sensorless.

## Chapter 6 – Inspection and replacement

LS Vector Inverter, STARVERT-iV5, is an industrial electronic product that adopts up-to-date semiconductor device. It may have a failure caused by the ambient environment such as temperature, humidity, vibration, etc. or an excessive use of the component over its duration. It requires a routine checking to prevent such failure in advance.

### 6.1 Precautions



#### CAUTION

- Before starting the maintenance work, the operator must check out the power input of the inverter.
- Large-capacity electrolytic condenser in the power electronic circuit remains charged with power even after the power is off. So be sure to start the maintenance work after you acknowledged the power has been completely discharged using a proper tester.
- Be sure to use a rectifier type volt meter to obtain an accurate voltage when directly measuring the output voltage of inverter. General volt meter or digital volt meter may result in spurious operation or indicate wrong value due to high frequency PWM output voltage of the inverter.

### 6.2 Checking Points

Electronic product is not intended for a permanent use. When it exceeds the duration even under the normal service environment, the product may have trouble in its operation due to change in the nature of the parts. To prevent such circumstance, it requires a routine and regular checking.

Especially if you use it under the following environment, have it checked with a shorter interval than the regular checking.

- When the temperature is relatively high in the installed place
- When the product is operated with a frequent start and stop
- When the input AC power and load vary seriously
- When it has severe vibration or shock
- When there is corrosive gas, combustible gas, oil sludge, dust, salts, metal powder, etc

## 6. Inspection and Replacement



### CAUTION

- The failure of the device used in the inverter may not be predicted in advance. The failure of the device may cause the error of input power fuse or the fault trip. If you are suspicious of the failure of device, please contact our sales representative.

### 6.3 Routine Checking

Area	Checking points	Description	How to Check	Judgment Criterion	Instrument
Overview	Ambient environment	Check ambient temperature, humidity, existence of dust, etc..	See the Caution for Safety.	Ambient temperature should be -10 ~ +40 degree C; Freezing is not allowed; Ambient humidity to be 50% or less; Dew is not allowed.	Temperature meter, Humidity meter, Recorder
	Entire system	Isn't there any vibration or unusual sound?	Judgement by visual or auditory sense.	There must be no unusual record.	-
	Power, Voltage	Is the main circuit voltage normal	Check the voltage among R, S, and T phases on the inverter terminal .block	-	Digital Multi Meter /Tester
Main circuit	Flat condenser	1) Isn't the liquid inside leaked? 2) Isn't the safety vent protruded? No sagging phenomenon?	Check 1) and 2) by eyes.	There must be no unusual result from 1) and 2).	-
Cooling system	Cooling fan	1) Isn't there any unusual vibration or unusual sound?	1) Turn it using hand with the power Off.	1) Rotate it softly	-

## 6. Inspection and Replacement

Area	Checking points	Description	How to Check	Judgment Criterion	Instrument
	Inverter, Motor	Do they have excessive heat?	<ol style="list-style-type: none"> <li>1) Check if it is from overload or not.</li> <li>2) Fasten the screw tightly.</li> <li>3) Check if the inverter's heat sink is polluted.</li> <li>4) Check the ambient temperature.</li> </ol>	There must be no unusual record.	Temperature meter
Indicator	Meter	Is the indicator value normal	Check the indicator value on the display of the panel surface.	Check the value under the regulation and standard value.	Volt Meter, Current Meter, etc.
Motor	Entire system	<ol style="list-style-type: none"> <li>1) Isn't there any unusual vibration or unusual sound?</li> <li>2) Isn't there any unusual smell?</li> </ol>	<ol style="list-style-type: none"> <li>1) Check by ear, hand, and eye.</li> <li>2) Check overheat, damage, etc.</li> <li>3) Check the area connected with the machine.</li> <li>4) Measure the vibration of the motor.</li> <li>5) Fasten the screw on the junction tightly.</li> </ol>	There must be no unusual record.	-

## 6. Inspection and Replacement

### 6.4 Regular Checking (1 year interval)

Area	Checking points	Description	How to Check	Judgment Criterion	Instrument
Main circuit	Entire system	1) Megger checking (between the main circuit terminal and ground terminal) 2) Isn't any fixed area missing? 3) Isn't there any trace of overheat on each component?	1) Unfasten the connection of inverter, connect R, S, T, U, V, and W terminals, and then measure the gap between this area and the ground terminal using a megger. 2) Fasten the screws. 3) Check it visually	1) To be 5MΩ or more There must be no unusual result from 2) and 3)	DC 500V Class Megger
	Conductor /Wire	1) Isn't there any corrosion on the conductor? 2) Isn't there any damage to the wire sheath?	1) Switch the power Off and then turn it with a hand. 2) Fasten it once again.	1) Rotate it softly 2) There must be no unusual record	.
	Terminal block	Isn't it damaged?	Check by eyes.	There must be no unusual record	.
	Flat condenser	Measure the electrostatic capacity	Measure using the capacity meter.	85% or more of the rated capacity	Capacity meter.
	Relay	1) Isn't there any chattering sound? 2) Isn't there any damage to the contact point?	1) Check by ears. 2) Check by eyes.	There must be no unusual record	.

## 6. Inspection and Replacement

Area	Checking points	Description	How to Check	Judgment Criterion	Instrument
	Resistance	<p>1) Isn't there any damage to the insulation resistance?</p> <p>2) Check the existence of the clue</p>	<p>1) Check by eyes.</p> <p>2) Remove the connection at one side, and measure it using a tester.</p>	<p>1) There must be no unusual record</p> <p>2) It should be within <math>\pm 10\%</math> tolerance range</p>	Digital Multi-Meter/Analog Tester
	Diode, IGBT	Check if they are stained with trash or dust	Check by eyes.	Remove them by blowing a dry air.	,
	Circuit Board	<p>1) Check if they generate unusual smell are discolored, rusted, covered with dust or oil mist</p> <p>2) Check if the connector is mounted</p>	Check by eyes	<p>1) Clean it using anti-static cloth or cleaner. If not, replace with new circuit board</p> <p>2) Do not clean the circuit board using the solution.</p> <p>3) Remove trash or dust by blowing a dry air.</p> <p>4) Mount the connectors again.</p> <p>5) If the damaged area cannot be repaired or is the part that cannot be replaced, replace the inverter itself.</p>	,

## 6. Inspection and Replacement

Area	Checking points	Description	How to Check	Judgment Criterion	Instrument
Control circuit protecting circuit	Operation	1) Check the unbalance of the output voltage during the operation of inverter 2) Display circuit must not have any unusual phenomenon after the sequence protecting operation test is done	1) Measure the voltage among the U, V, and W at the Inverter output terminal. 2) Have the inverter protecting circuit output shorted out or open it by force.	1) Balance of inter-phase voltage 200V (400V) Use: Within 4V(8V) 2) Unusual circuit to be operated in sequence	Digital Multi-Meter/ DC type Volt Meter
Cooling System	Cooling fan, Cooling pin	1) Isn't there any looseness on the junction? 2) Isn't cooling pin or cooling fan covered with dust	1) Fasten it once again. 2) Check with eyes and then remove dust	1) There must be no unusual record 2) There must be no dust	-
Indicator	Meter	Is the indicator value normal?	Check the indicator value on the display of the panel surface.	Check the value under the regulation and standard value	Volt Meter/ Current Meter, etc.

### 6.5 Meggar Test

- ① For Exterior main circuit, remove all cables from inverter terminals to ensure that test voltage is not applied to the inverter.
- ② Use DC 500V meggar and isolate the main power before starting measurement. If the test voltage is connected to the control circuit, remove all connection cables to the control circuit.
- ③ Perform the Meggar test only between the common cables connected to the main circuit and ground.

### 6.6 Regular Checking (2 year interval)

Area	Checking points	Description	How to Check	Judgment Criterion	Instrument
Main circuit	Entire system	Megger Checking (between the main circuit terminal and the ground terminal)	Unfasten the connection of the inverter, and then measure the gap among R, S, T, U, V, and W terminals and this area after having them shorted out.	5MΩ or more	DC 500V Class Megger
Motor	Resistance Insulation	Megger checking (between the output terminal and the ground terminal)	Unfasten the connection among U, V, and W, and then bind the motor wiring.	5MΩ or more	500V Class Megger

### 6.7 Replacement Interval and Maintenance of the Key Components

Inverter constitutes a number of electronic parts including semiconductor device. The parts used in the inverter are subject to change as time elapses for its construction or nature. Therefore without any replacement of parts, it may cause failure or deterioration in the performance the inverter. For this reason, it requires regular replacement of the parts.

Name of parts	Standard interval for replacement	Symptoms	How to Replace and Countermeasure
Cooling Fan	2 ~ 3 years	Poor Rotation	Replacement into new part
DC Link condenser	5 years	Reduction in Capacity	Replacement into new part
Control Panel Flat Condenser	5 years	Reduction in Capacity	Replacement into new part
Control Board Relay	-	Poor Operation	Replacement into new part



## 6. Inspection and Replacement

Name of parts	Standard interval for replacement	Symptoms	How to Replace and Countermeasure
Braking Resistance	-	Reduction in Capacity	Replacement into new part

- Duration of the key components is based on the continuous operation at a rated load. Therefore the duration is subject to change depending on the service condition and ambient environment.

### 6.8 How to Check at Diode Module & IGBT Inspection

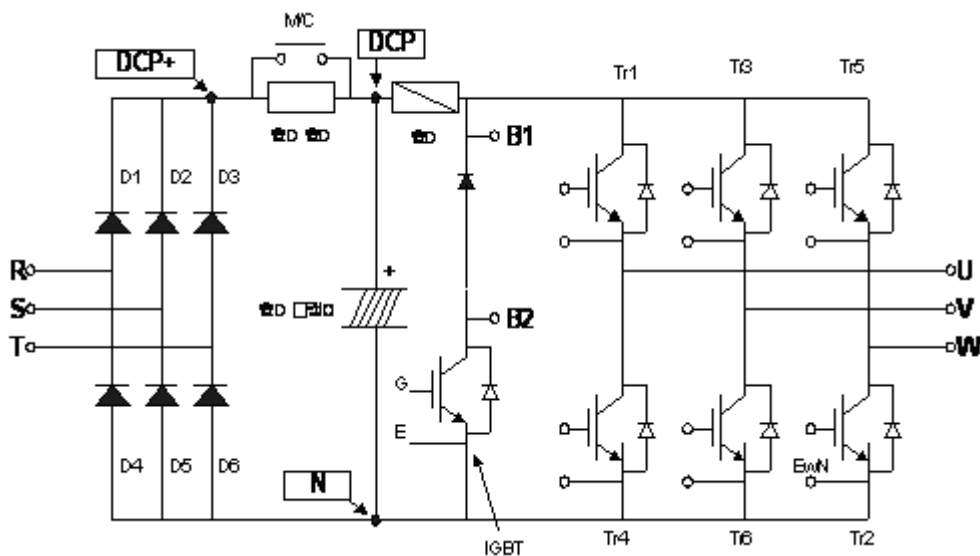

- Remove the power source wire (R, S, T) and the motor output wire (U, V, W) connected from the outside
- Check and determine whether R, S, T, U, V, W, B1 (or P/L1), N of the inverter terminal block are turned on or not by changing the polarity of the tester between each other.
- Perform the test after making sure that the electrolytic condenser is discharged.
- When they are not turned on, they will indicate several mega resistance values. It may indicate several mega resistance values when it is turned on for a moment owing to the influence of electrolytic condenser. When they are turned on, it indicates several  $\Omega$  ~ dozens of  $\Omega$ . The indicator value varies depending on the type of module, the type of tester, etc., but such values are shown in a similar range when it is sound product.

## Chapter 7 – Troubleshooting and maintenance

### 7.1 Fault Display



#### CAUTION

When a fault occurs, the inverter turns off its output and displays the fault status described below. In this case, the cause must be corrected before the fault can be cleared. If protective function keeps active, it could lead to reduction in product life and damage to the equipment.

Protective function	Keypad display	Description
Over Current	OC-U OC-V OC-W	The inverter turns off its output when the output current of the inverter flows more than 200% of the inverter rated current.
Ground Fault Protection	Ground Fault	The inverter turns off its output when a ground fault occurs and the ground fault current is more than the internal setting value of the inverter. Over current trip function may protect the inverter when a ground fault occurs due to a low ground fault resistance.
Over voltage protection	Over Voltage	The inverter turns off its output if the DC voltage of the main circuit increases higher than the rated value (200V class: 400V DC, 400V class: 820 V DC) when the motor decelerates or when regenerative energy flows back to the inverter due to a regenerative load. This fault can also occur due to a surge voltage generated at the power supply system.
Low Voltage Protection	Low Voltage	The inverter turns off its output if the DC voltage is below the detection level (200V class: 180Vdc, 400V class: 360Vdc) because insufficient torque or over heating of the motor can occurs when the input voltage of the inverter drops.
Overload Protection	Over Load	The inverter turns off its output if the output current of the inverter flows at 180% of the inverter rated current for more than the current limit time (S/W).
Inverter Overload	Inv OLT	The inverter turns off its output when the rated current of the inverter flows more than regulation level (150% for 1 minute-Inversely proportional to time).
Heat Sink Over Heat	InvOver Heat	The inverter turns off its output if the heat sink over heats due to a damaged cooling fan or an alien substance in the cooling fan by detecting the temperature of the heat sink.
	OHD Open	The inverter turns off its output when OHD is opened and

## 7. Troubleshooting and Maintenance

Protective function	Keypad display	Description
	*1)	the heat sink is overheated.
Inverter NTC Thermistor Open	InvThem OP	When inverter NTC Thermistor is open, inverter stops its output.
Motor overheat	MotOver Heat	When motor temp exceeds 150°C , inverter stops its output to protect motor from overheated.
Motor Thermistor Error	MotThem Err	When there is an error in Thermistor that measures the temperature of motor, inverter stops its output. (Error—NTC: open , PTC: short-circuit)
Electronic Thermal	E-Thermal	The internal electronic thermal of the inverter determines the over heating of the motor. If the motor is overloaded the inverter turns off the output. The inverter cannot protect the motor when driving a multi-pole motor or when driving multiple motors, so consider thermal relays or other thermal protective devices for each motor. Overload capacity: 150% for 1 min.
External fault B	Ext Trip-B	Use this function if the user needs to turn off the output by an external fault signal.
IGBT Short	Arm Short Arm Short-DB	Inverter output is stopped when IGBT Arm short or output short occurs. (Arm Short-DB is only come under SV110~220iV5)(
Fuse Open	Fuse Open	The inverter turns off its output by opening the fuse when something is wrong with the main circuit IGBT to protect the wiring from being damaged from short currents
Encoder Error	Encoder Err	1) Displayed when Encoder signal fault occurs.(H/W) 2) Displayed when there is a discord of detection time standard of motor error of PAR-14.(S/W)
BX protection (Instant Cut Off)	BX	Used for the emergency stop of the inverter. The inverter instantly turns off the output when the BX terminal is turned ON, and returns to regular operation when the BX terminal is turned OFF. Take caution when using this function.
Motor overspeed	Over Speed	Displayed when motor rotates over 120% its rated speed.
Communication Error	COM Error CPU Error	Displayed when the inverter cannot communicate with the keypad.

## 7. Troubleshooting and Maintenance

Protective function	Keypad display	Description
H/W Error	HW-Diag	Displayed when CPU has a problem, and then the inverter blocks the IGBT gating signals.
FAN Lock*1)	FAN Lock	The inverter turns off its output when there is an Fan Lock.
Encoder Power Error*1)	Enc Power	When there is an error in Encoder power source, the inverter turns off its output. Converted to initial screen and displayed "EPR" on the right upper side.
Input Phase Open	Input PO	It cuts off the output from the inverter in a condition that a power is not supplied to a phase among the 3-phase input on the enough loads.
Output Phase Open	Output PO	It cuts off the output from the inverter through detecting the status of flowing of the current.
AC FAN and M/C Power Fault	FAN/MC PWR	Displayed when the step down transformer for AC FAN and M/C power input or Input fuse connected to transformer has a fault. (AC input type 30~160kW)
		It cuts off the output to prevent the inverter from damage when the power of 220V has not supplied to AC FAN and M/C. (DC input type 230~160kW)
AC FAN Power Fault	FAN PWR	Displayed when the step down transformer for AC FAN and M/C power input or input fuse for transformer has a fault. (AC input type 220kW)
		It cuts off the output to prevent the inverter from damage when the power of 220V has not supplied to AC FAN. (DC input type 220kW and AC/DC input type 500kW)

\*1) It only comes under SV2800~5000iV5.

### 7.2 Monitoring Fault Condition

#### 7.2.1 Monitoring fault display

Code	LCD display	Description
DIS_05	OC-U	Current fault displayed. (U-phase overcurrent)

- Check the current fault display before pressing reset key. pressing [PROG] key and [▲(Up)],[▼(Down)] shows operating status at the time of the fault such as output frequency, current, voltage, F/B value, torque current reference/actual value, dc link voltage, input/output terminal status, operating status and run time) and the fault contents. Press [ENT] key to exit. Pressing [RESET] key will store the value in DIS\_05 [Last Fault1].

#### 7.2.2 Monitoring previous faults

- Previous 2 faults are saved in DIS\_05 “Last fault 1/2“. Last fault 1 is more recent fault than Last fault 2. Refer to “7.2.1 monitoring fault display” to check the fault contents.

Code	LCD display	Description
DIS_05	Last Fault1	Previous fault 1
DIS_05	Last Fault2	Previous fault 2

- DIS\_05 “ Fault Clear” removes Last Fault1, Last Fault2 data.

### 7.3 Fault Reset

There are 3 ways to reset the inverter. After performing this, the number of automatic restart is initialized.

- 1) Use [RESET] key on the keypad.
- 2) Short the RST-CM terminal to reset.
- 3) Cycle the power (turn the power OFF and turn it ON).

### 7.4 Fault Remedy

#### 7.4.1 Check the below diagnosis before troubleshooting.

- 1) Is the wiring of a motor and an inverter conducted correctly?
  - ☞ Refer to Main Circuit Terminal.
- 2) Is the Encoder-type jumper on I/O PCB set correctly?
  - ☞ Refer to Encoder wiring

If encoder type is either Complementary or Open collector, slide JP4 switch to “OC” and slide JP2 switch to “P15”. If encoder type is Line Drive, slide the JP4 switch to “LD” and slide JP2 switch to “P5”.

Factory default: Line Drive Type

3) Is motor rotating direction set correctly?

☞ Refer to Monitoring Encoder operation.

**STARVERT-iV5 defines Forward rotation when motor rotates in clockwise from the view of Rear Bracket (Motor FAN).**

4) Is inverter operating correctly in no load condition?

☞ Refer to Operation via Keypad and Control Terminal.

### 7.4.2 Check list before installation

Check 1) ~ 9) before installation. Check 10) ~ 16) when problem has occurred during use.

#### 1) The Motor Does Not Rotate

① Is red lamp blinking ?

☞ Check whether other trips occur in DIS\_05.

If fault occurs, press [RESET] key to clear trip status and try operation.

☞ Check whether BX (Emergency stop) signal is applied on keypad and input terminal defined as BX is ON in DIS\_03. If so, release BX and try operation.

DIS	▶	Terminal In
03		0010000000

② RUN/STOP method is properly set?

☞ Check FUN\_01 RUN/STOP method setting matches the actual operation mode (RUN/STOP via keypad or terminal). If FUN\_01 is set to terminal but operation is not performed, change it to keypad mode and try operation. If FUN\_02 is set to Keypad but operation is not performed, change it to Terminal and try operation. If either way cannot work, refer to No. 6).

#### 2) The motor does not rotate when Green lamp on [REV], [FWD] key is ON.

① Is inverter U, V, W output correctly wired to motor U, V, W output?

☞ Refer to Main circuit terminal.

## 7. Troubleshooting and Maintenance

- ② Is the motor shaft jammed by brake or other mechanical devices?
  - ☞ check the directly connected brake's relay on time and brake open time.
- ③ On DIS\_01 PreRamp Ref, is speed reference displayed not "0"?
  - ☞ set the desired speed reference if it is set to "0". If it is incorrectly set, refer to No. 7).
- ④ Is PAR\_07 [motor rating] properly set?
  - ☞ check the motor nameplate and setting matches.
- ⑤ Is PAR\_16 [motor speed] properly set?
  - ☞ check the motor nameplate and setting matches.
- ⑥ Is PAR\_22 [motor rated current] properly set?
  - ☞ check the motor nameplate and setting matches.
- ⑦ Is PAR\_26 [motor flux current] properly set?
  - ☞ If LG-OTIS vector motor is not used, consult LS representative or set the correct value in accordance with application. However, it cannot set to exceed PAR\_22 [motor rated current]. Normally it is 30~40 % of rated motor current.
- ⑧ Is PAR\_21 [motor rated slip] properly set?
  - ☞ check the motor nameplate and setting matches.
- ⑨ Is PAR\_27 [Motor secondary time constant (Tr) properly set?
  - ☞ if motor is not LG-OTIS vector motor, perform the Auto-tuning or set this correctly. If it is incorrectly set, inverter performance will be dramatically deteriorated.
- ⑩ Is PAR\_19 [number of motor poles] properly set?
  - ☞ check the motor nameplate and setting matches.
- ⑪ CON\_28 [Torque limit setting] is set to " Kpd Kpd Kpd ". Is CON\_29 ~ CON\_31 setting correct?
  - ☞ CON\_29 ~ CON\_31 marks upper limit in inverter output torque. For the application lower torque limit is required, when torque shortage occurs, increase this value a little. STARVERT-iV5 's overload capacity is 150%/1 min. when using torque limit over 150%, time and the number of use should be limited.
- ⑫ When CON\_28 [torque limit setting] Analog or Option, the corresponding input value is properly set?
  - ☞ CON\_28 is set to Analog, one of Ai1/Ai2/Ai3 should be defined as "Torque limit". If set to Option, refer to Option manual for proper setting.

### 3) Motor speed is not increasing while it is running.

- ① Is PAR\_10 [number of Encoder pulse] set properly?
  - ☞ factory default is 1024. If it is not OTIS vector motor, contact with Encoder maker.
- ② FUN\_01 is set to “Keypad”, FUN\_02 to “Keypad1”, FUN\_12(Speed 0) to 100.0rpm and press [FWD] key but motor speed is not 100.0rpm. In this case, check for encoder wiring.
  - ☞ If encoder wiring is disconnected or switched, it rotates only uni-direction with low speed (30.0 ~ 60.0rpm) and over 150% its rated current. Check the encoder wiring and whether wiring of defined terminal and motor encoder terminal is shorted.
- ③ If motor speed does not increase and keeps abnormally 30.0 ~ 60.0 rpm, stop the motor and switch the wiring of A and B phase of Encoder. Check whether motor rotating direction is reversed as seen in No. 4).
  - ☞ In the case of Line Drive type encoder, wire A+, A- phase to B+, B- and B+, B- phase to A+, A-.
  - Complementary / for the case of Open Collector type encoder, reverse the wiring of PA and PB.
  - Or switch the encoder direction in **PAR 11 (Enc Dir Set) and try RUN.**

### 4) Motor rotates in reverse direction.

- ☞ Switch the wiring of output phase V and W. Switch the wiring of encoder phase A and B as indicated in No. 3).
- Or switch the encoder direction in PAR 11(Enc Dir Set) and try RUN.**

### 5) Motor rotating direction cannot be changed.

- ① Is RUN/STOP setting proper?
  - ☞ Check FUN\_01 RUN/STOP command setting matches the actual operating mode. If FUN\_01 is set to Terminal (Keypad) but operation cannot be made, change it to Keypad (Terminal). If it does not work, refer to No. 6).



## 7. Troubleshooting and Maintenance

- ② Is one of the terminal defined as FWD/REV Run Disable ON?
  - ☞ Check one of DIO\_01 ~ DIO\_07 terminals is defined as “Prohibit FWD” or “Prohibit REV”. If so, check input terminal status in DIS\_01 ~ DIS\_03. If rotating direction is not changed, check the terminal is ON.

### 6) Keypad or terminal malfunctions.

- ① When [REV], [FWD], [STOP] key on the keypad is lit Red or Green,
  - ☞ Refer to 1) if RUN/STOP is not activated by Keypad or Terminal. If setting change is not available, PAR\_04 may set to prohibit parameter write. To release this setting, enter 12 in PAR\_04. If problem persists, contact LS representatives.
- ② When [STOP] key is blinking,
  - ☞ This marks trip condition or BX active status. Check any other trips occur in DIS\_05. Reset the trip and try run. Check BX signal is ON on the keypad and input terminal signal in DIS\_01 ~ DIS\_03. Reset BX and try run.
- ③ When green lamp on [REV], [FWD] key is blinking,
  - ☞ It marks accel/decel is in operation. If inverter keeps operation in this condition, it means load capacity calculation is incorrect and exceeds inverter rating. Refer to No. 16).

### 7) Operating speed does not change during run.

- ① Is FUN\_02 speed setting proper?
  - ☞ Speed setting methods in STARVERT-iV5 are Analog input, Keypad and Option. Select appropriate one among them.
- ② Is DIS\_01(PreRamp Ref) setting the correct value?
  - ☞ Current speed ref. Values are displayed in DIS\_01 ~ DIS\_03. Check the displayed value matches the setting value. If speed is not variable, check the encoder. Refer to No. 13).
- ③ Speed setting method is “Keypad” and speed ref displayed DIS\_01 ~ DIS\_03 is not correct.
  - ☞ Check terminal setting in DIO\_01 ~ DIO\_07 defined as Multi-step speed setting.
- ④ When speed setting method is Analog and DIS\_01 ~ DIS\_03 display is not

desired value,

- ☞ Check one of Ai1 ~ Ai3 is defined as “Speed Ref.”.

### 8) Motor keeps rotating at OV condition when speed setting is via Analog input.

- ① When AIO\_11 Definition of Ai1 input is set to “Speed Ref”,
  - ☞ Adjust the Ai1\_Bias at AIO\_14. (Setting unit: %).  
The displayed value is speed command. Set the desired value (ex : 0.0%) and press [ENTER] key.
- ② Follow the same steps to check Ai2 ~ Ai3.

### 9) Motor detects speed reference but motor rpm is showing decreasing while motor is overheated or hunting.

- ① Check the motor wiring.
  - ☞ There is a possibility of incorrect motor wiring when motor is 220V / 380V dual rating. Motor does not normally rotate when pole number setting is incorrect. However, motor may get damaged in case of miswiring. If this problem occurs, contact motor sales office. Refer to Power terminal description in this manual.
- ② Is motor capacity set correctly?
  - ☞ Check PAR\_07 motor rating selection is set the same as motor in use. See the nameplate for motor rating.
- ③ Is motor parameter set correctly?
  - ☞ Motor parameters vary by manufacturer. STARVERT-iV5 setting is based on OTIS vector motor as default. Motor parameters should be changed when other makers' motor is used.

### 10) Nothing displayed on the LCD?

- ① Is the connection of inverter and keypad tight?
  - ☞ Check the inverter and Keypad connection.
- ② Is input power turned on?
  - ☞ Check inverter power is applied. If nothing is displayed on the LCD in this condition, contact LS representatives.

### 11) Motor speed oscillates and speed is not constant during constant Run.

- ① Is encoder wired using twisted shield cable?
  - ☞ encoder signal wiring should be conducted with Twisted Shield Cable. Otherwise, speed may oscillate at low speed (or high speed) due to encoder input noise, leading to motor vibration or abnormal motor sound at stop.
- ② Is the connection of inverter and motor and encoder grounding proper?
  - ☞ Check the grounding of inverter and encoder is connected. This could occur when not connected. Fixed screw for the connection of encoder grounding and the inverter is located on the right bottom side of the control PCB. Loosen the fixed screw and insert the ground wire of the encoder and tighten the screw. (Refer to encoder wiring diagram). For grounding the motor, use G of the inverter Main terminal.
- ③ Connect inverter panel grounding connected with motor grounding to the building grounding.
  - ☞ If not, incorrect motor speed may be input due to encoder input noise.
- ④ Is too large speed gain assigned to the inverter while motor load is light?
  - ☞ Motor oscillates at stop when PI gain is set much larger than the actual load in CON\_03 and CON\_04. Therefore, gain should be set accordingly. Responsiveness increases when P gain is set higher and I lower but system may become unstable. Gain value varies system but generally set **30 ~ 70%** for **P gain** and set **100 ~ 500ms** for **I gain**.
- ⑤ Increase PAR\_13 Enc LPF setting value.
- ⑥ Is there slip present at the connection of encoder and motor shaft?
  - ☞ Poor encoder and motor connection may generate slip. Check the connection is tight.

### 12) Parameter change is not saved.

- ☞ Turn the power off and turn it on. If problem persists, contact LS representatives.

### 13) “Fuse Open” trip occurs constantly.

- ① Is the input (line) voltage normal?
  - ☞ Check the line voltage input. If phase to phase unbalance exceeds 2%(greater than 6V for 380V input), an AC reactor should be provided. Otherwise, inverter may get damaged and A/S fee will be charged during Warranty period.
- ② Is the phase sequence of the output terminal U, V, W correct?
  - ☞ Check the level of the input signal.
- ③ Is the motor insulation damaged?
  - ☞ Various types of malfunction occur when the insulation is damaged. In general, operation stops at a certain speed (and more), overload or “OC-U (V, W)” trip occurs during regenerating. Or motor overheating and rotating speed oscillates. This condition persists for a while and then “Fuse Open” trip occurs. It marks motor insulation is damaged. In this case, replace the motor.

### 14) Motor input current is too large.

- ① Check the motor wiring.
  - ☞ Check the motor wiring for the use of 220V / 380V transition type motor. (Refer to Main circuit terminal)
- ② Are motor and inverter capacity set correctly?
- ③ Is the setting of motor constants appropriate?
  - ☞ Refer to No. 2) and No. 9) and check the motor and inverter setting.

### 15) OC-U (V, W) trip occurs frequently during operation. (Motor input current is oscillating.)

- ① Check the encoder installation.
  - ☞ If encoder connection is poor, motor vibration affects encoder and incorrect encoder signal is input to the inverter. Vector inverter controls the speed from Encoder F/B value so it follows the input signal whether correct or not, increasing inverter current. If so, contact motor maker or encoder commission company.
- ② Is there no inverter output phase loss?

## 7. Troubleshooting and Maintenance

---

③ Is the motor insulation not damaged?

☞ Refer to No. 13) and check the inverter and motor.

### **16) Accel/Decel cannot be made properly and green lamp in [REV], [FWD] key is blinking. (load and frequency reference signal is oscillating.)**

① Check motor wiring.

② FUN\_40 ~ FUN\_47 Accel/Decel time and DIS\_00 motor load.

☞ Blinking Green lamp marks motor is accelerating or decelerating. If the rotating speed oscillates and green lamp is blinking, it marks inverter output torque shortage due to mis-calculation of load. In this case, increase the torque limit to enable inverter to accelerate/decelerate within its rating. If load is set too high, it will shorten inverter life or damage to the unit.

## Chapter 8 – Accessories

### 8.1 MCCB(LS), ELB(LS), Magnetic Contactor(LS), Input/Output Wire Specifications

Voltage	Motor (kW)	Inverter models	MCCB, ELB (LS)	Magnetic contactor (LS)
200V	2.2	SV022iV5-2DB	TD125U/30A, EBS33b30A	MC-18a
	3.7	SV037iV5-2DB	TD125U/30A, EBS33b30A	MC-32a
	5.5	SV055iV5-2DB	TD125U/50A, EBS53b50A	MC-40a
	7.5	SV075iV5-2DB	TD125U/60A, EBS63b60A	MC-50a
	11	SV110iV5-2DB	TD125U/100A, EBS103b100A	MC-65a
	15	SV150iV5-2DB	TD125U/125A, EBS203b125A	MC-100a
	18.5	SV185iV5-2DB	TS250U/150A, EBS203b150A	MC-130a
	22	SV220iV5-2DB	TS250U/175A, EBS203b175A	MC-150a
	30	SV300iV5-2	TS250U/225A, EBS203b225A	MC-150a
37	SV370iV5-2	TS400U/300A, EBS403b300A	MC-225a	
400V	2.2	SV022iV5-4DB	TD125U/15A, EBS33b15A	MC-12a
	3.7	SV037iV5-4DB	TD125U/15A, EBS33b15A	MC-18a
	5.5	SV055iV5-4DB	TD125U/30A, EBS33b30A	MC-22b
	7.5	SV075iV5-4DB	TD125U30A, EBS33b30A	MC-32a
	11	SV110iV5-4DB	TD125U/50A, EBS53b50A	MC-40a
	15	SV150iV5-4DB	TD125U/60A, EBS103b60A	MC-50a
	18.5	SV185iV5-4DB	TD125U/80A, EBS103b80A	MC-65a
	22	SV220iV5-4DB	TD125U/100A, EBS103b100A	MC-65a
	30	SV300iV5-4(380V)	TD125U/125A, EBS203b125A	MC-100a
	37	SV370iV5-4(380V)	TS250U/150A, EBS203b150A	MC-130a
	45	SV450iV5-4(380V)	TS250U/175A, EBS203b175A	MC-150a
	55	SV550iV5-4(380V)	TS250U/225A, EBS203b225A	MC-185a
	75	SV750iV5-4(380V)	TS400U/300A, EBS403b300A	MC-225a
	90	SV900iV5-4(380V)	TS400U/400A, EBS403b400A	MC-330a
	110	SV1100iV5-4(380V)	TS800U/500A, EBS603b500A	MC-400a
	132	SV1320iV5-4(380V)	TS800U/600A, EBS603b600A	MC-400a
	160	SV1600iV5-4(380V)	TS800U/600A, EBS603b600A	MC-630a
	220	SV2200iV5-4(380V)	ABS803/800A, EBS803b800A	MC-800a
	280	SV2800iV5-4	ABS1003/1000A, EBS1003b1000A	1000A
315	SV3150iV5-4	ABS1203/1200A, EBS1203b1200A	1200A	
375	SV3750iV5-4	1400A, 1400A	1400A	
500	SV5000iV5-4	1600, 1600A	1600A	

## 8. Accessories

※ Please refer to our LS ELECTRIC MCCB, ELB and MC catalog for the your order. The product indicated with only current will be released in the near future.

### 8.2 AC input fuse, AC reactor, DC reactor

Voltage	Motor (kW)	Inverter models	AC input fuse	AC reactor	DC reactor
200V	2.2	SV022iV5-2DB	25 A	0.88 mH, 14 A	-
	3.7	SV037iV5-2DB	40 A	0.56 mH, 20 A	-
	5.5	SV055iV5-2DB	40 A	0.39 mH, 30 A	-
	7.5	SV075iV5-2DB	50 A	0.28 mH, 40 A	-
	11	SV110iV5-2DB	70 A	0.20 mH, 59 A	-
	15	SV150iV5-2DB	100 A	0.15 mH, 75 A	-
	18.5	SV185iV5-2DB	100 A	0.12 mH, 96 A	-
	22	SV220iV5-2DB	125 A	0.10 mH, 112 A	-
	30	SV300iV5-2	150A	0.08 mH, 134 A	0.35 mH, 152 A
37	SV370iV5-2	200A	0.07 mH, 160 A	0.30 mH, 180 A	
400V	2.2	SV022iV5-4DB	10 A	3.23 mH, 7.5 A	-
	3.7	SV037iV5-4DB	20 A	2.34 mH, 10 A	-
	5.5	SV055iV5-4DB	20 A	1.22 mH, 15 A	-
	7.5	SV075iV5-4DB	30 A	1.14 mH, 20 A	-
	11	SV110iV5-4DB	35 A	0.81 mH, 30 A	-
	15	SV150iV5-4DB	45 A	0.61 mH, 38 A	-
	18.5	SV185iV5-4DB	60 A	0.45 mH, 50 A	-
	22	SV220iV5-4DB	70 A	0.39 mH, 58 A	-
	30	SV300iV5-4(380V)	100 A	0.33 mH, 67 A	1.19 mH, 76 A
	37	SV370iV5-4(380V)	100 A	0.27 mH, 82 A	0.98 mH, 93 A
	45	SV450iV5-4(380V)	100 A	0.22 mH, 100 A	0.89 mH, 112 A
	55	SV550iV5-4(380V)	150 A	0.15 mH, 121 A	0.75 mH, 135 A
	75	SV750iV5-4(380V)	200 A	0.13 mH, 167 A	0.44 mH, 187 A
	90	SV900iV5-4(380V)	250 A	0.11 mH, 201 A	0.35 mH, 225 A
	110	SV1100iV5-4(380V)	300 A	0.09 mH, 245 A	0.30 mH, 274 A
	132	SV1320iV5-4(380V)	400 A	0.08 mH, 290 A	0.26 mH, 324 A
	160	SV1600iV5-4(380V)	400 A	0.06 mH, 357 A	0.22 mH, 399 A
	220	SV2200iV5-4(380V)	800A	0.029mH, 799 A	0.1mH, 530 A
	280	SV2800iV5-4	900A	0.029mH, 799 A	0.090mH, 836 A
315	SV3150iV5-4	1000A	0.024mH, 952 A	0.076mH, 996 A	
375	SV3750iV5-4	1200A	0.024mH, 952 A	0.064mH, 1195 A	
500	SV5000iV5-4	1600A	0.021mH, 1248A	-	

※ For 2.2~22kW, DC reactor standard is not provided, for not having DC reactor wiring terminal.

### 8.3 The Selection of Braking Resistor and the Unit

#### 8.3.1 The selection of dynamic braking resistor

Resistor values shown in the following table is calculated on the basis of 150% of rated braking torque, 5% ED 1).

Power rating of resistor should be doubled for resistor frequency 10% ED use. Additional braking unit should be installed for above SV 300iV5-2 / SV300iV5-4.

Inverter	Rated Capacity (5% ED)	
	[Ω]	[W] <sup>(2)</sup>
SV 022iV5-2 DB	50	400
SV 037iV5-2 DB	33	600
SV 055iV5-2 DB	20	800
SV 075iV5-2 DB	15	1200
SV 110iV5-2 DB	10	2400
SV 150iV5-2 DB	8	2400
SV 185iV5-2 DB	5	3600
SV 220iV5-2 DB	5	3600
SV 022iV5-4 DB	200	400
SV 037iV5-4 DB	130	600
SV 055iV5-4 DB	85	800
SV 075iV5-4 DB	60	1200
SV 110iV5-4 DB	40	2400
SV 150iV5-4 DB	30	2400
SV 185iV5-4 DB	20	3600
SV 220iV5-4 DB	20	3600

- ✓ (1) : ED is based on 100 seconds.
- ✓ (2) : Rated capacity is based on the self-cooling.

#### 8.3.2 Wiring of the temperature sensor on braking resistor

Temperature sensor is attached in the LS ELECTRIC braking resistors to prevent the fire.

Terminal of Braking Resistor	Power Terminal of Inverter	Action
B1, B2	P, BR	-
P7, CM	One of the multi-function input terminals (P1 ~ P7)	Contact is normally ON at the ambient temperature



## 8. Accessories

	should be set to 'External Fault Signal b Contact'.	and is OFF in case of over-temperature.
--	---	---

### 8.3.3 Braking unit

- ① SV037DBH-2 : 37kW/200V Class Braking Unit (10% ED)
  - ② SV037DBH-4 : 37kW/400V Class Braking Unit (10% ED)
  - ③ SV075DBH-4 : 75kW/400V Class Braking Unit (10% ED)
  - ④ SV075DB-4 : 75kW/400V Class Braking Unit (100% ED)
  - ⑤ SV220DB-4 : 220kW/400V Class Braking Unit (100% ED)
- The Combination of two braking unit for 400V class is possible for more than SV900iV5-4 capacity.
  - When ED is more than 10%, Use the braking unit for 100% ED (Ex: vertical load such as crane, hoist).
  - When the inverter capacity is more than 220kW, use the braking unit for SV220DB-4 (100% ED).
  - Refer to description manual included in braking unit product for the use of 100% ED braking unit.

### 8.3.4 Combination of braking unit

Inverter Braking unit		SV□□□□ iV5-2	SV□□□□iV5-4				
		300/370	300/370	450/550/750	900/1100/ 1320/1600	2200	2800/3150/ 3750
200V	37kW	1	-	-	-	-	-
400V	37kW	-	1	-	-	-	-
	75kW	-	-	1	2	-	-
	220kW	-	-	-	-	1	2

Note)

1. Example) Combine two braking units of 75kW-400V Class for SV-900iV5-4(90kW) Class.
2. Refer to the Braking Unit user manual that came with the braking unit.
3. Please contact to LS ELECTRIC customer service center about above 200kW.

### 8.3.5 Braking resistor for braking unit

Braking Unit	100% of Braking Torque, 10% ED	
	Resistance [ $\Omega$ ]	Rated Power [kW]
37kW-200V	3	5
37kW-400V	12	5
75kW-400V	6	10
75kW-400V	6	Refer to extra manual in the case of 100% ED braking unit.
220kW-400V	2	

**MEMO**

A large rectangular area with horizontal dotted lines, intended for taking notes or a memo.

## Chapter 9 – Dimensions

- SV 022, 037, 055, 075, 110, 150, 185, 220iV5-2DB (MD)
- SV 022, 037, 055, 075, 110, 150, 185, 220iV5-4DB (MD) (MD: Mold type)

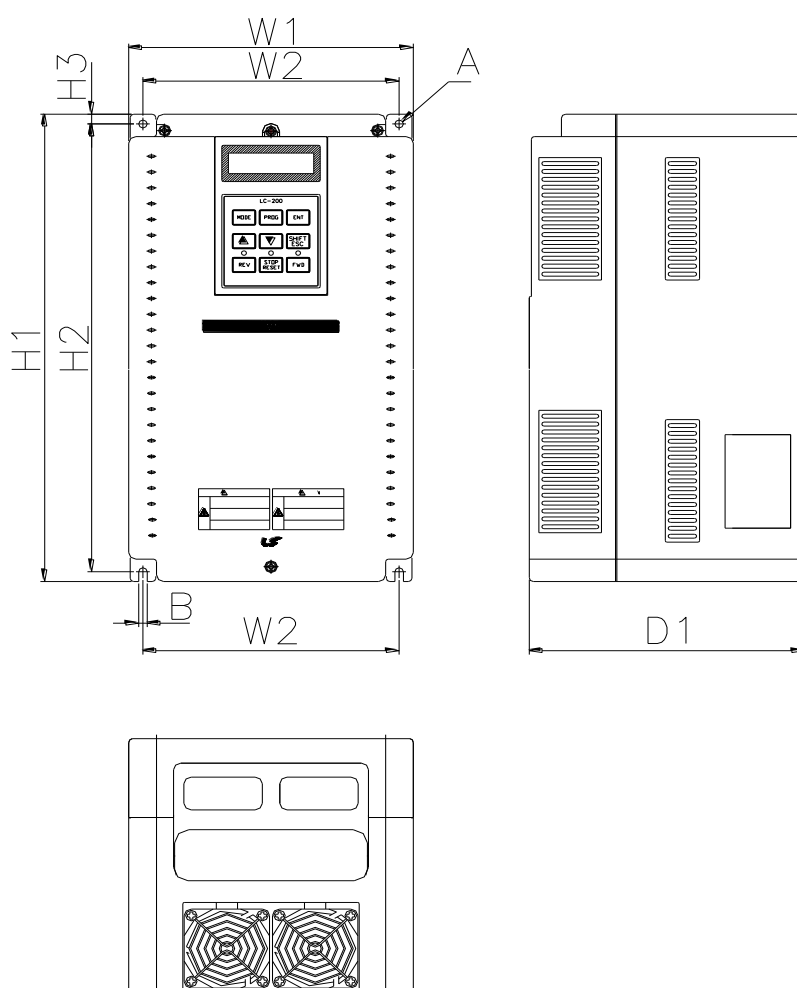

### ● Dimensions (unit: mm [inches])

Model [kW]	W1	W2	H1	H2	H3	D1	A	B
2.2/3.7 - 2/4	200	180	284	269	7.5	207	6	6
	[7.87]	[7.09]	[11.18]	[10.69]	[0.29]	[8.15]	[0.23]	[0.23]
5.5/7.5 - 2/4			355	340	7.5	202	6	6
			[13.97]	[13.38]	[0.29]	[7.95]	[0.23]	[0.23]
11/15 - 2/4	250	230	385	370	7.5	221	9	9
	[9.84]	[9.06]	[15.16]	[14.57]	[0.29]	[8.70]	[0.35]	[0.35]
18.5/22 - 2/4	304	284	460	445	7.5	254	9	9
	[11.97]	[11.18]	[18.11]	[17.52]	[0.29]	[10.00]	[0.35]	[0.35]

## 9. Dimensions

- SV055, 075, 110, 150, 185, 220iV5-2 DB
- SV055, 075, 110, 150, 185, 220iV5-4 DB
- SV055, 075, 110, 150, 185, 220iV5-4 DC (DC: DC power input type)

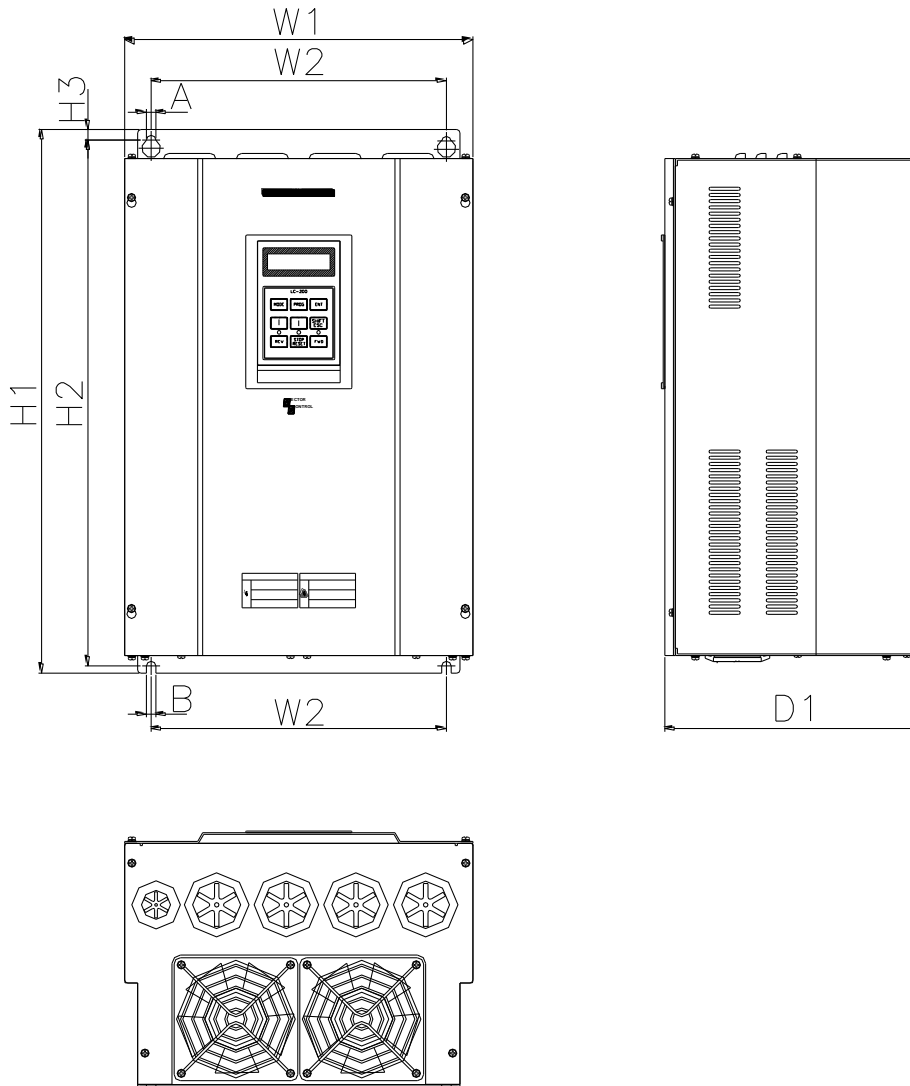

### ● Dimensions (unit: mm [inches])

\*DC has a same dimension as AC.

Model [kW]	W1	W2	H1	H2	H3	D1	A	B
5.5/7.5 - 2/4	234.4 [9.22]	180 [7.08]	406.2 [15.9]	391.2 [15.4]	7.5 [0.29]	221.1 [8.7]	6 [0.23]	6 [0.23]
11/15/18.5/22 - 2/4	335 [13.1]	284 [11.1]	526 [20.7]	509 [20.0]	10 [0.39]	248.6 [9.78]	9 [0.35]	9 [0.35]

- SV300, 370iV5-2
- SV300, 370, 450, 550, 750iV5-4
- SV300, 370, 450, 550, 750iV5-4 DC (DC: DC power input type)

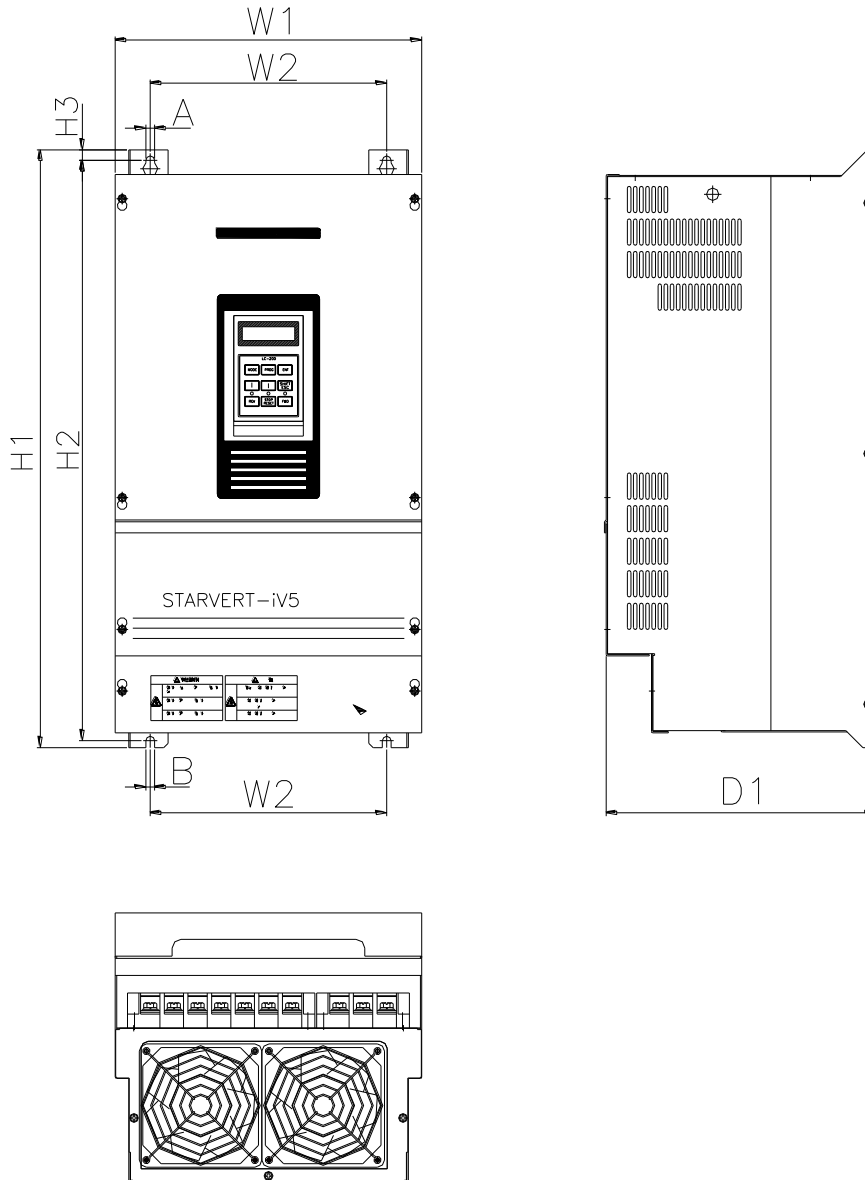

● Dimensions (unit: mm [inches])

\*DC has a same dimension as AC.

Model [kW]	W1	W2	H1	H2	H3	D1	A	B
30/37 – 2/4	350 [13.7]	270 [10.6]	680 [26.7]	660 [26.0]	12 [0.47]	308.2 [12.1]	10 [0.39]	10 [0.39]
45/55/75 - 4	375 [14.7]	275 [10.8]	780 [30.7]	758.5 [29.8]	11 [0.43]	326 [12.8]	11 [0.43]	11 [0.43]

## 9. Dimensions

- SV900, 1100, 1320, 1600iV5-4
- SV900, 1100, 1320, 1600iV5-4 (DC: DC power input type)

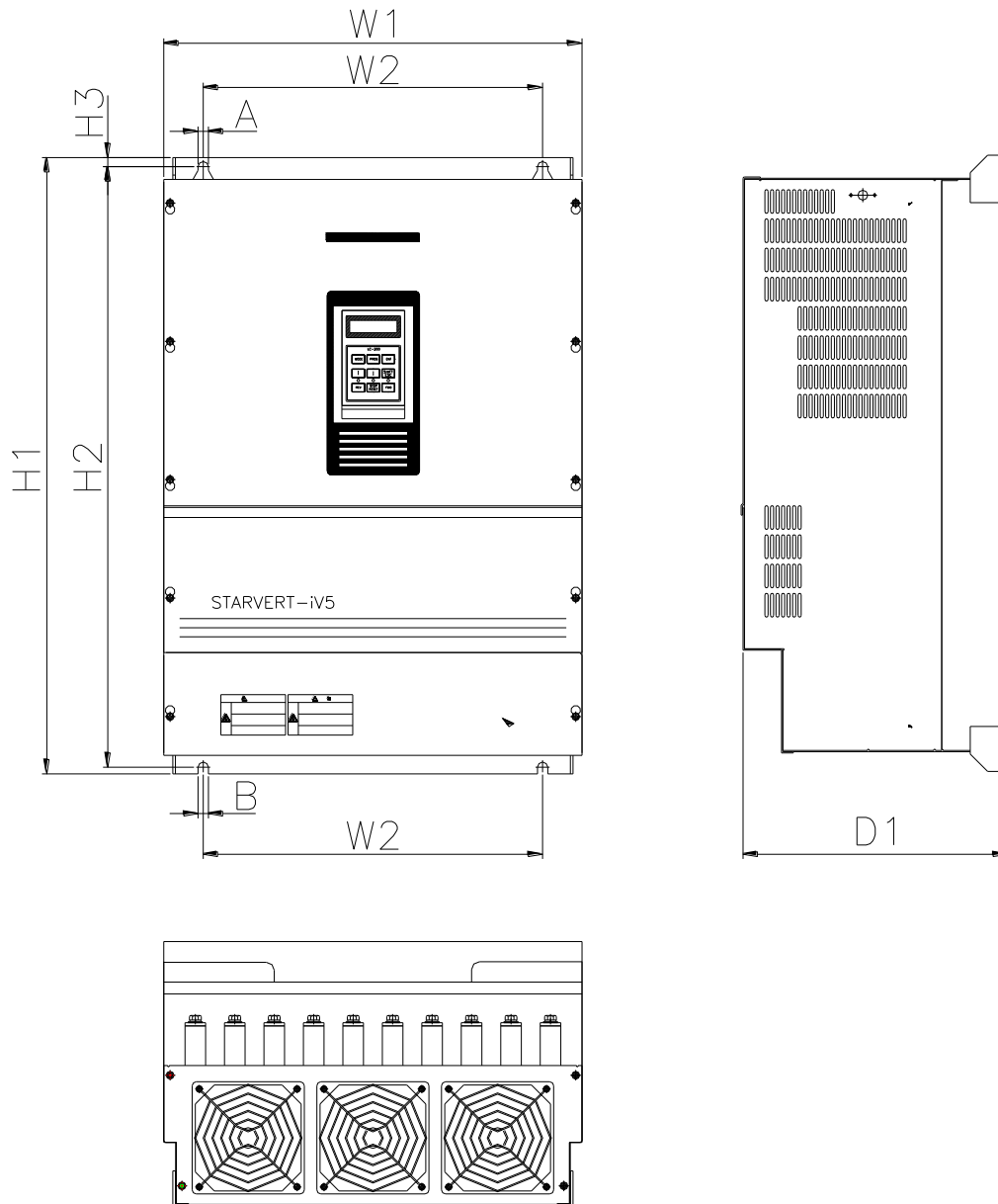

### ● Dimensions (unit : mm[inches])

\*DC has a same dimension as AC.

Model [kW]	W1	W2	H1	H2	H3	D1	A	B
90/110 - 4	530 [20.8]	430 [16.9]	780 [30.7]	760 [29.9]	11.5 [0.45]	335 [13.2]	13 [0.51]	13 [0.51]
132/160 - 4	530 [20.8]	430 [16.9]	1000 [39.3]	980 [38.5]	11.5 [0.45]	345 [13.5]	13 [0.51]	13 [0.51]

- SV2200iV5-4
- SV2200iV5-4DC (DC: DC power input type)

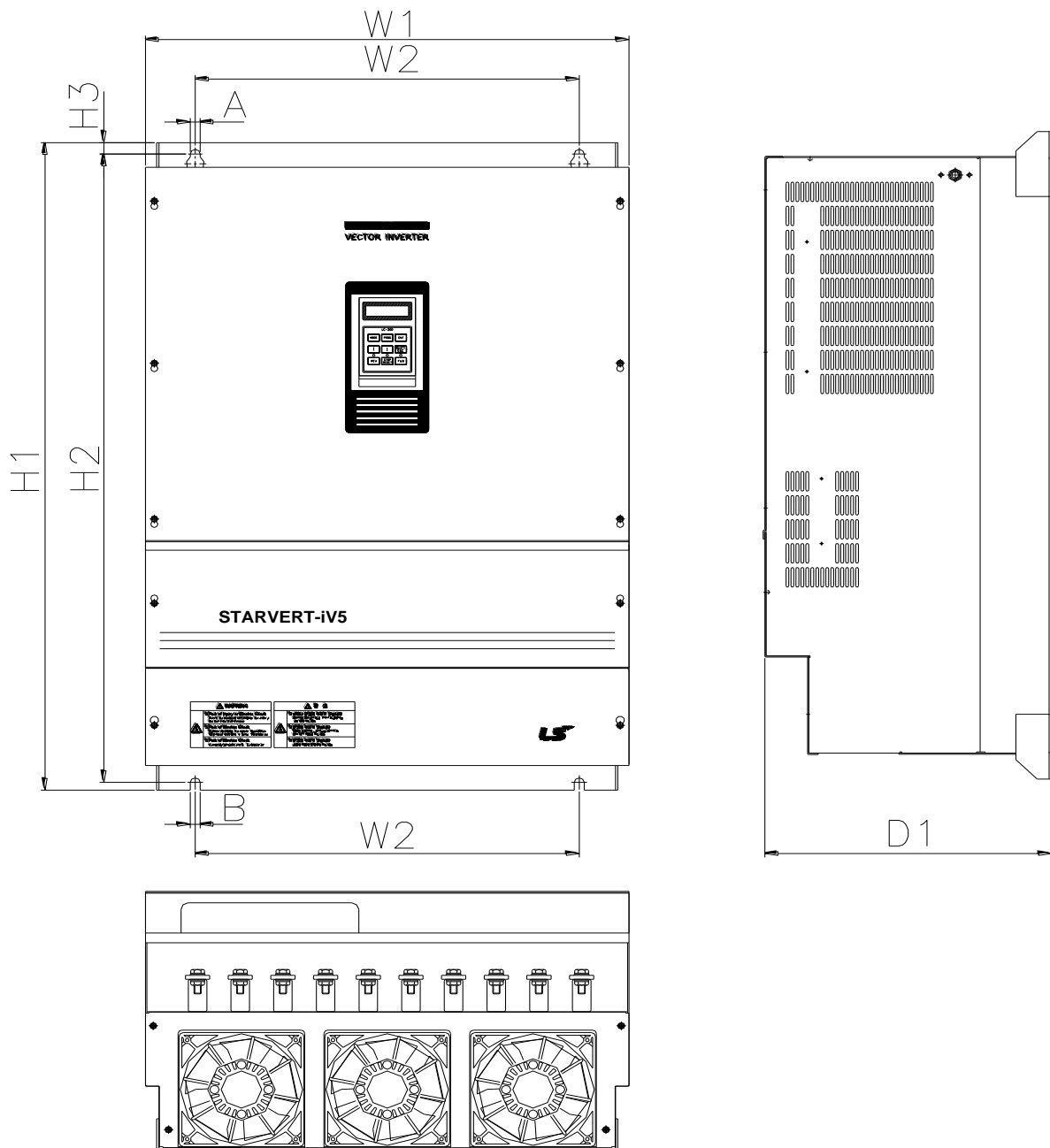

● Dimensions (unit : mm[inches])

\*DC has a same dimension as AC.

Model [kW]	W1	W2	H1	H2	H3	D1	A	B
220 - 4	680 [26.77]	540 [21.26]	998 [39.29]	968.5 [38.13]	17.5 [0.68]	403 [15.87]	14 [0.55]	14 [0.55]



## 9. Dimensions

- SV2800, 3150, 3750iV5-4
- SV2800, 3150, 3750iV5-4DC (DC: DC power input type)

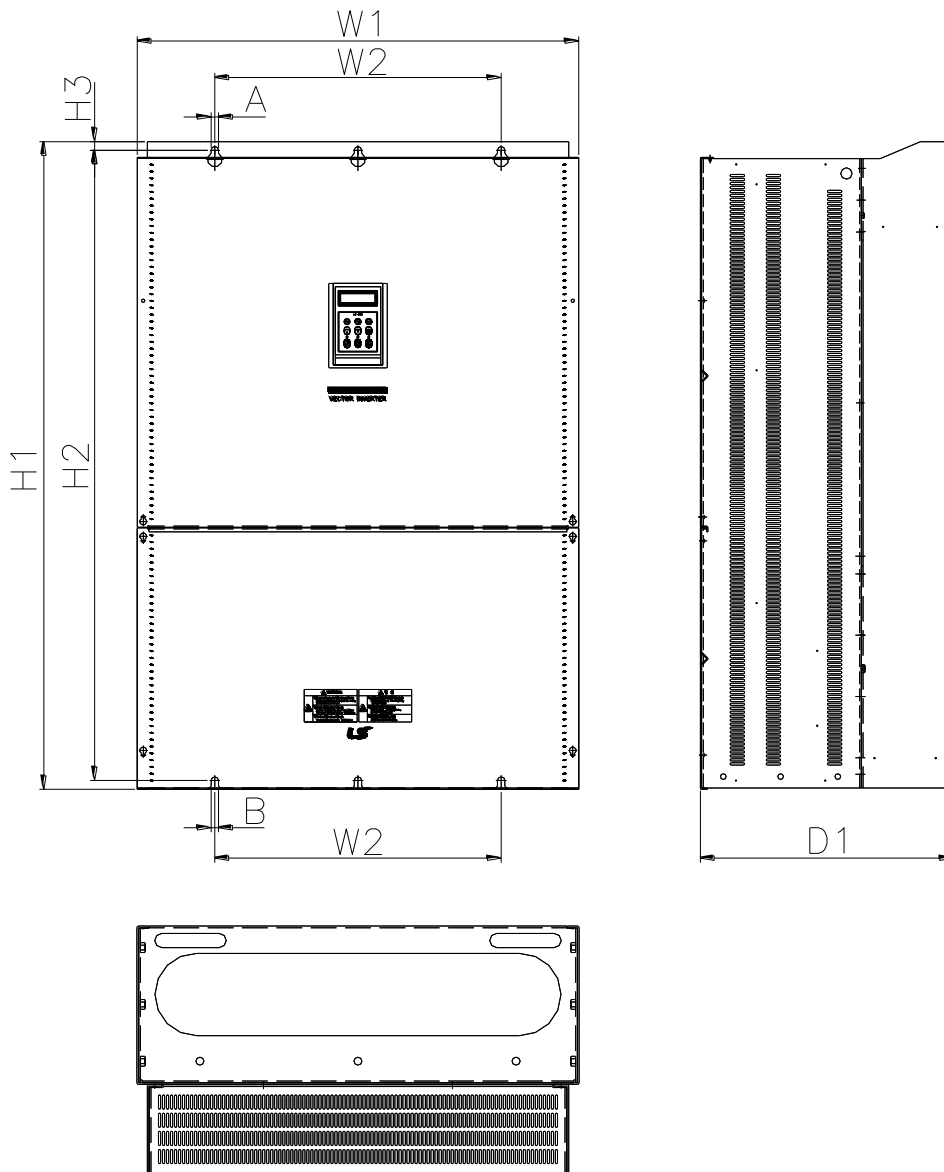

### ● Dimensions (unit : mm[inches])

\*DC has a same dimension as AC.

Model [kW]	W1	W2	H1	H2	H3	D1	A	B
280 - 4	772 [30.39]	500 [19.69]	1140.5 [44.90]	1110 [43.70]	15 [0.59]	442 [17.40]	13 [0.51]	13 [0.51]
315/375 - 4	922 [36.30]	580 [22.83]	1302.5 [51.28]	1271.5 [50.06]	15.5 [0.61]	495 [19.49]	14 [0.55]	14 [0.55]

- SV5000iV5-4
- SV5000iV5-4DC (DC: DC power input type)

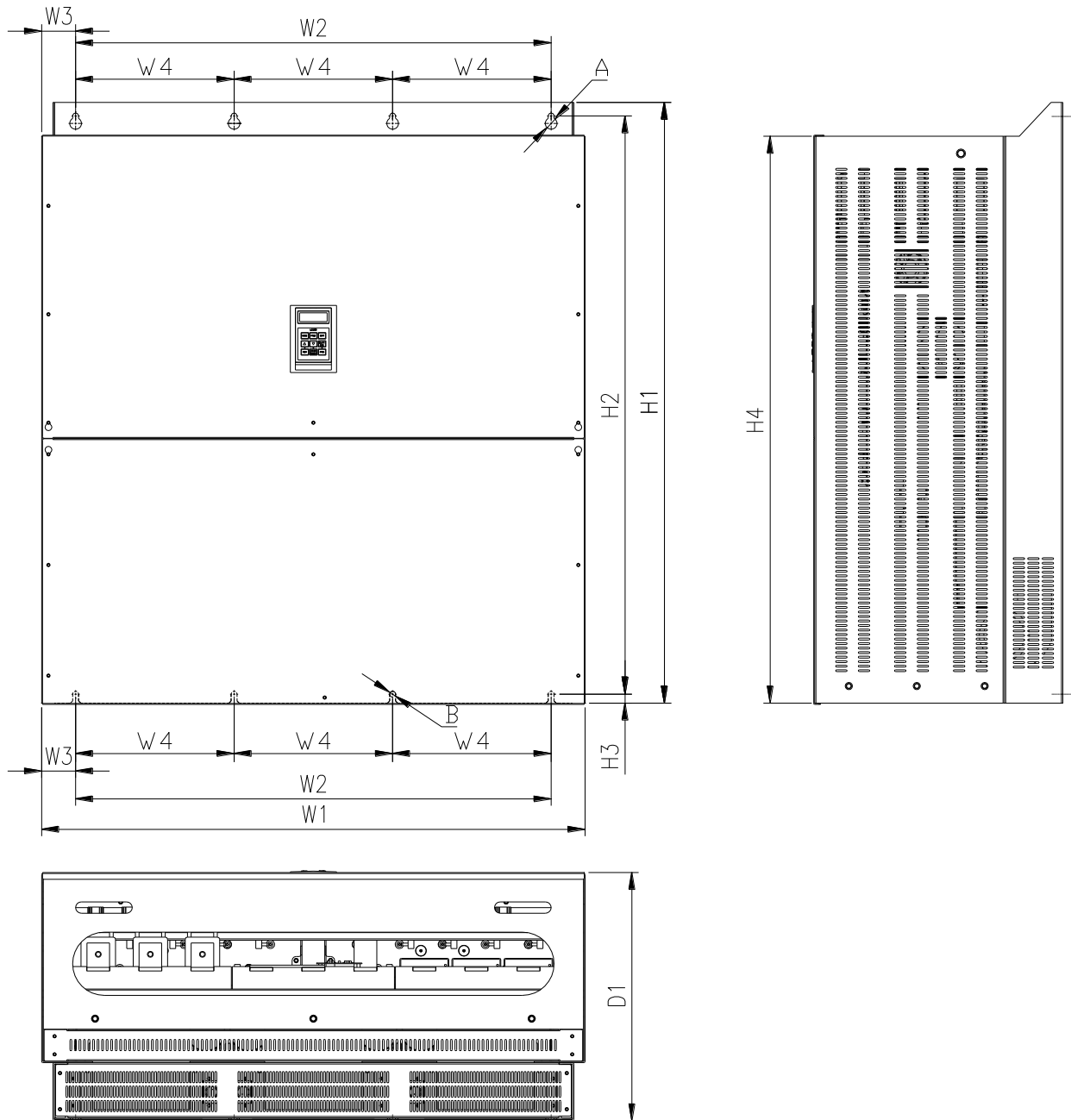

● Dimensions (unit : mm[inches]) \*DC has a same dimension as AC.

Model [kW]	W1	W2	W3	W4	H1	H2	H3	H4	D1	A	B
500kW - 4	1200 (47.25)	1050 (41.34)	75 (2.95)	350 (13.78)	1330 (52.36)	1280 (50.39)	20 (0.79)	1225 (48.23)	550 (21.65)	26 (10.24)	13 (0.51)

## ADDITIONAL UL MARKING

### 1. Short Circuit Rating

“Suitable For Use On A Circuit Capable Of Delivering Not More Than Table1\* RMS Symmetrical Amperes, 240 for rated 240V drives or 480 for rated 480V drives Volts Maximum,” or equivalent.

Table1\*

Inverter Capacity	Rating
200/400V Class: 5.5kW, 7.5kW, 11kW, 15kW, 18.5 kW, 22kW, 30kW, 37kW	5,000A
400V Class: 45kW, 55kW, 75kW, 90kW, 110kW, 132kW	10,000A
400V Class: 160kW, 220kW	18,000A

### 2. SHORT CIRCUIT FUSE/BREAKER MARKING

Use Class H or K5 UL Listed Input Fuse and UL Listed Breaker Only. See the table below for the Voltage and Current rating of the fuses and the breakers.

Input [V]	Inverter [kW]	External Fuse		Breaker		Internal Fuse		Manufacturer	Model Number
		Current [A]	Voltage [V]	Current [A]	Voltage [V]	Current [A]	Voltage [Vac/dc]		
200 Class	5.5	40	500	50	220	60	250	Hinode Elec	250GH-60
	7.5	50	500	60	220	60	250		250GH-60
	11	70	500	100	220	125	250		250GH-125
	15	100	500	100	220	150	250		250GH-150
	18.5	100	500	225	220	175	250		250GH-175
	22	125	500	225	220	225	250		250GH-225
	30	150	500	225	220	250	250		250GH-250S
	37	200	500	225	220	250	250		250GH-250S
400 Class	5.5	20	500	30	460	35	660		660GH-35
	7.5	30	500	30	460	35	660		660GH-35
	11	35	500	50	460	63	660		660GH-63
	15	45	500	60	460	80	660		660GH-80
	18.5	60	500	100	460	100	660		660GH-100
	22	70	500	100	460	125	660		660GH-125
	30	100	500	100	460	125	600		600FH-125S
	37	100	500	225	460	150	600		600FH-150S
	45	100	500	225	460	200	600	600FH-200S	
	55	150	500	225	460	200	600	600FH-200S	
	75	200	500	225	460	125	600	600FH-125S	
	90	250	500	400	460	200	600	600FH-200S	
	110	300	500	400	460	200	600	600FH-200S	
	132	400	500	400	460	300	600	600FH-300S	
160	400	500	400	460	300	600	600FH-300S		
220	—	—	600	460	600	600	600SPF-600UL		

### 3. FIELD WIRING TERMINAL

- 1) Use Copper wires only with Copper conductors, 75°C
- 2) Input and motor output terminal blocks are intended only for use with ring type connectors.

### 4. CAUTION-Risk of Electric Shock

“Before opening the cover, disconnect all power and wait at least 10 minutes”  
Units suitable only for use in a pollution degree 2 environment. Be sure to mount the inverter in a forced-ventilated operating panel.



## EMI / RFI POWER LINE FILTERS LS inverters, iV5 series



### RFI FILTERS

THE LS RANGE OF POWER LINE FILTERS FF ( Footprint ) - FE ( Standard ) SERIES, HAVE BEEN SPECIFICALLY DESIGNED WITH HIGH FREQUENCY LG INVERTERS. THE USE OF LS FILTERS, WITH THE INSTALLATION ADVICE OVERLEAF HELP TO ENSURE TROUBLE FREE USE ALONG SIDE SENSITIVE DEVICES AND COMPLIANCE TO CONDUCTED EMISSION AND IMMUNITY STANDARDS TO EN 50081.

### CAUTION

IN CASE OF A LEAKAGE CURRENT PROTECTIVE DEVICES IS USED ON POWER SUPPLY, IT MAY BE FAULT AT POWER-ON OR OFF. IN AVOID THIS CASE, THE SENSE CURRENT OF PROTECTIVE DEVICE SHOULD BE LARGER THAN VALUE OF LAKAGE CURRENT AT WORST CASE IN THE BELOW TABLE.

### RECOMMENDED INSTALLATION INSTRUCTIONS

To conform to the EMC directive, it is necessary that these instructions be followed as closely as possible. Follow the usual safety procedures when working with electrical equipment. All electrical connections to the filter, inverter and motor must be made by a qualified electrical technician.

- 1- ) Check the filter rating label to ensure that the current, voltage rating and part number are correct.
- 2- ) For best results the filter should be fitted as closely as possible to the incoming mains supply of the wiring enclosure, usually directly after the enclosures circuit breaker or supply switch.
- 3- ) The back panel of the wiring cabinet of board should be prepared for the mounting dimensions of the filter. Care should be taken to remove any paint etc... from the mounting holes and face area of the panel to ensure the best possible earthing of the filter.
- 4- ) Mount the filter securely.
- 5- ) Connect the mains supply to the filter terminals marked LINE, connect any earth cables to the earth stud provided. Connect the filter terminals marked LOAD to the mains input of the inverter using short lengths of appropriate gauge cable.
- 6- ) Connect the motor and fit the ferrite core ( output chokes ) as close to the inverter as possible. Armoured or screened cable should be used with the 3 phase conductors only threaded twice through the center of the ferrite core. The earth conductor should be securely earthed at both inverter and motor ends. The screen should be connected to the enclosure body via and earthed cable gland.
- 7- ) Connect any control cables as instructed in the inverter instructions manual.

IT IS IMPORTANT THAT ALL LEAD LENGHTS ARE KEPT AS SHORT AS POSSIBLE AND THAT INCOMING MAINS AND OUTGOING MOTOR CABLES ARE KEPT WELL SEPARATED.

FF SERIES ( Footprint )

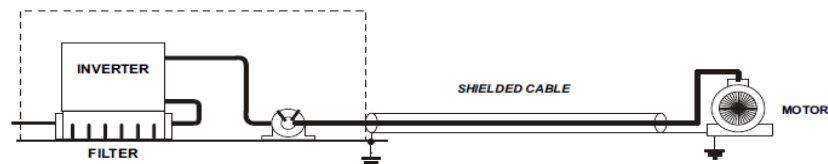

FE SERIES ( Standard )

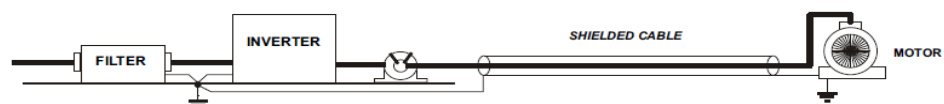

iV5 series / Footprint Filters													
INVERTER	POWER	CODE	CURRENT	VOLTAGE	LEAKAGE CURRENT	DIMENSIONS			MOUNTING	WEIGHT	MOUNT	FIG	OUTPUT CHOKES
					NOM.	MAX.	L	W	H	Y	X		
<b>THREE PHASE</b>													
SV022iV5-2 (DB)	2.2kW	FFV5-T020-(x)	20A	250VAC	0.5mA	27mA	329x199.5x60	315x160	1.8Kg.	M5	A	FS-2	
SV037iV5-2 (DB)	3.7kW												
SV055iV5-2 (DB)	5.5kW	FFV5-T030-(x)	30A	250VAC	0.5mA	27mA	451x234.5x60	437x190	2.1Kg.	M5	A	FS-2	
SV075iV5-2 (DB)	7.5kW	FFV5-T050-(x)	50A	250VAC	0.5mA	27mA	451x234.5x60	437x190	2.6Kg.	M5	A	FS-2	
SV110iV5-2 (DB)	11kW	-	100A	250VAC	0.5mA	27mA	-	-	-	-	-	-	
SV150iV5-2 (DB)	15kW												
SV185iV5-2 (DB)	18kW	-	120A	250VAC	0.5mA	27mA	-	-	-	-	-	-	
SV220iV5-2 (DB)	22kW												
SV300iV5-2 (DB)	30kW	-	150A	250VAC	0.5mA	27mA	-	-	-	-	-	-	
SV370iV5-2 (DB)	37kW												
SV022iV5-4 (DB)	2.2kW	FFV5-T011-(x)	11A	380VAC	0.5mA	27mA	329x199.5x60	315x160	1.5Kg.	M5	A	FS-2	
SV037iV5-4 (DB)	3.7kW												
SV055iV5-4 (DB)	5.5kW	FFV5-T030-(x)	30A	380VAC	0.5mA	27mA	451x234.5x60	437x190	2Kg.	M5	A	FS-2	
SV075iV5-4 (DB)	7.5kW	FFV5-T051-(x)	51A	380VAC	0.5mA	27mA	605x335x65	579.5x265	2.5Kg.	M8	A	FS-2	
SV110iV5-4 (DB)	11kW												
SV150iV5-4 (DB)	15kW	FFV5-T060-(x)	60A	380VAC	0.5mA	27mA	605x335x65	579.5x265	2.8Kg.	M8	A	FS-2	
SV185iV5-4 (DB)	18kW												
SV220iV5-4 (DB)	22kW	FFV5-T070-(x)	70A	380VAC	0.5mA	27mA	605x335x65	579.5x265	2.8Kg.	M8	A	FS-3	
SV300iV5-4 (DB)	30kW	FFV5-T071-(x)	71A	380VAC	0.5mA	27mA	756x350x65	730.5x281	3Kg.	M8	A	FS-3	
SV370iV5-4 (DB)	37kW	-	100A	380VAC	0.5mA	27mA	-	-	-	-	-	-	
SV450iV5-4 (DB)	45kW												
SV550iV5-4 (DB)	55kW	-	120A	380VAC	0.5mA	27mA	-	-	-	-	-	-	
SV750iV5-4 (DB)	75kW												
SV900iV5-4 (DB)	90kW	-	230A	380VAC	0.5mA	27mA	-	-	-	-	-	-	
SV1100iV5-4 (DB)	110kW												
SV1320iV5-4 (DB)	132kW	-	400A	380VAC	0.5mA	27mA	-	-	-	-	-	-	
SV1600iV5-4 (DB)	160kW												
SV2200iV5-4 (DB)	220kW	-	600A	380VAC	0.5mA	27mA	-	-	-	-	-	-	
SV2800iV5-4 (DB)	280kW												
SV3150iV5-4 (DB)	315kW	-	1000A	380VAC	0.5mA	27mA	-	-	-	-	-	-	
SV3750iV5-4 (DB)	375kW												
SV055iV5-2DB (MD)	5.5kW	FFV5-T031-(x)	31A	250VAC	0.5mA	27mA	400x199.5x60	386x160	2Kg.	M5	A	FS-2	
SV075iV5-2DB (MD)	7.5kW	FFV5-T052-(x)	52A	250VAC	0.5mA	27mA	400x199.5x60	386x160	2.5Kg.	M5	A	FS-2	
SV110iV5-2DB (MD)	11kW	-	100A	250VAC	0.5mA	27mA	-	-	-	-	A	FS-2	
SV150iV5-2DB (MD)	15kW												
SV185iV5-2DB (MD)	18kW	-	120A	250VAC	0.5mA	27mA	-	-	-	-	A	FS-2	
SV220iV5-2DB (MD)	22kW												
SV055iV5-4DB (MD)	5.5kW	FFV5-T031-(x)	31A	380VAC	0.5mA	27mA	400x199.5x60	386x160	2Kg.	M5	A	FS-2	
SV075iV5-4DB (MD)	7.5kW												
SV110iV5-4DB (MD)	11kW	FFV5-T053-(x)	53A	380VAC	0.5mA	27mA	466x258x65	440.5x181	2.5Kg.	M5	A	FS-2	
SV150iV5-4DB (MD)	15kW												
SV185iV5-4DB (MD)	18kW	FFV5-T061-(x)	61A	380VAC	0.5mA	27mA	541x312x65	515.5x235	2.6Kg.	M8	A	FS-2	
SV220iV5-4DB (MD)	22kW	FFV5-T072-(x)	72A	380VAC	0.5mA	27mA	541x312x65	515.5x235	2.8Kg.	M8	A	FS-3	

X (1) Industrial environment EN 50081-2 (A class) → EN61000-6-4: 02

(2) Domestic and industrial environment EN50081-1 (B class) → EN61000-6-3: 02

iV5 series / Standard Filters													
INVERTER	POWER	CODE	CURRENT	VOLTAGE	LEAKAGE CURRENT	DIMENSIONS L W H			MOUNTING Y X	WEIGHT	MOUNT	FIG.	OUTPUT CHOKES
THREE PHASE					NOM. MAX.								
SV022iV5-2 (DB)	2.2kW	FE-T020-(x)	20A	250VAC	0.5mA 27mA	270x140x60	258x106	2.2Kg.	---	B	FS-2		
SV037iV5-2 (DB)	3.7kW												
SV055iV5-2 (DB)	5.5kW	FE-T030-(x)	30A	250VAC	0.5mA 27mA	270x140x60	258x106	2.4Kg.	---	B	FS-2		
SV075iV5-2 (DB)	7.5kW	FE-T050-(x)	50A	250VAC	0.5mA 27mA	270x140x90	258x106	3.2Kg.	---	B	FS-2		
SV110iV5-2 (DB)	11kW	FE-T100-(x)	100A	250VAC	0.5mA 27mA	425x200x130	408x166	13.8Kg.	---	B	FS-3		
SV150iV5-2 (DB)	15kW												
SV185iV5-2 (DB)	18kW	FE-T120-(x)	120A	250VAC	0.5mA 27mA	425x200x130	408x166	13.8Kg.	---	B	FS-3		
SV220iV5-2 (DB)	22kW												
SV300iV5-2 (DB)	30kW	FE-T150-(x)	150A	250VAC	0.5mA 27mA	480x200x160	468x166	15Kg.	---	B	FS-3		
SV370iV5-2 (DB)	37kW	FE-T170-(x)	170A	250VAC	0.5mA 27mA	480x200x160	468x166	16Kg.	---	B	FS-3		
SV022iV5-4 (DB)	2.2kW	FE-T012-(x)	12A	380VAC	0.5mA 27mA	250x110x60	238x76	1.6Kg.	---	B	FS-2		
SV037iV5-4 (DB)	3.7kW												
SV055iV5-4 (DB)	5.5kW	FE-T030-(x)	30A	380VAC	0.5mA 27mA	270x140x60	258x106	2.4Kg.	---	B	FS-2		
SV075iV5-4 (DB)	7.5kW												
SV110iV5-4 (DB)	11kW	FE-T050-(x)	50A	380VAC	0.5mA 27mA	270x140x90	258x106	3.2Kg.	---	B	FS-2		
SV150iV5-4 (DB)	15kW												
SV185iV5-4 (DB)	18kW	FE-T060-(x)	60A	380VAC	0.5mA 27mA	270x140x90	258x106	3.5Kg.	---	B	FS-2		
SV220iV5-4 (DB)	22kW	FE-T070-(x)	70A	380VAC	0.5mA 27mA	350x180x90	338x146	7.5Kg.	---	B	FS-3		
SV300iV5-4 (DB)	30kW												
SV370iV5-4 (DB)	37kW	FE-T100-(x)	100A	380VAC	1.3mA 150mA	425x200x130	408x166	13.8Kg.	---	B	FS-3		
SV450iV5-4 (DB)	45kW												
SV550iV5-4 (DB)	55kW	FE-T120-(x)	120A	380VAC	1.3mA 150mA	425x200x130	408x166	13.8Kg.	---	B	FS-3		
SV750iV5-4 (DB)	75kW												
SV900iV5-4 (DB)	90kW	FE-T170-(x)	170A	380VAC	1.3mA 150mA	480x200x160	468x166	16Kg.	---	B	FS-3		
SV900iV5-4 (DB)	90kW	FE-T230-(x)	230A	380VAC	1.3mA 150mA	580x250x205	560x170	22.6Kg.	---	B	FS-4		
SV1100iV5-4 (DB)	110kW	FE-T400-(x)	400A	380VAC	1.3mA 150mA	392x260x116	240x235	10.3Kg.	---	C	FS-4		
SV1320iV5-4 (DB)	132kW												
SV1600iV5-4 (DB)	160kW	FE-T600-(x)	600A	380VAC	1.3mA 150mA	392x260x116	240x235	10.3Kg.	---	C	FS-4		
SV2200iV5-4 (DB)	220kW												
SV2800iV5-4 (DB)	280kW	FE-T1000-(x)	1000A	380VAC	1.3mA 150mA	460x280x166	290x255	18Kg.	---	C	FS-4		
SV3150iV5-4 (DB)	315kW												
SV3750iV5-4 (DB)	375kW												
SV055iV5-2DB (MD)	5.5kW	FE-T030-(x)	30A	250VAC	0.5mA 27mA	270x140x60	258x106	2.4Kg.	---	B	FS-2		
SV075iV5-2DB (MD)	7.5kW	FE-T050-(x)	50A	250VAC	0.5mA 27mA	270x140x90	258x106	3.2Kg.	---	B	FS-2		
SV110iV5-2DB (MD)	11kW	FE-T100-(x)	100A	250VAC	0.5mA 27mA	425x200x130	408x166	13.8Kg.	---	B	FS-3		
SV150iV5-2DB (MD)	15kW												
SV185iV5-2DB (MD)	18kW	FE-T120-(x)	120A	250VAC	0.5mA 27mA	425x200x130	408x166	13.8Kg.	---	B	FS-3		
SV220iV5-2DB (MD)	22kW												
SV055iV5-4DB (MD)	5.5kW	FE-T030-(x)	30A	380VAC	0.5mA 27mA	270x140x60	258x106	2.4Kg.	---	B	FS-2		
SV075iV5-4DB (MD)	7.5kW												
SV110iV5-4DB (MD)	11kW	FE-T050-(x)	50A	380VAC	0.5mA 27mA	270x140x90	258x106	3.2Kg.	---	B	FS-2		
SV150iV5-4DB (MD)	15kW												
SV185iV5-4DB (MD)	18kW	FE-T060-(x)	60A	380VAC	0.5mA 27mA	270x140x90	258x106	3.5Kg.	---	B	FS-2		
SV220iV5-4DB (MD)	22kW	FE-T070-(x)	70A	380VAC	0.5mA 27mA	350x180x90	338x146	7.5Kg.	---	B	FS-3		

X (1) Industrial environment EN 50081-2 (A class) → EN61000-6-4 :02

(2) Domestic and industrial environment EN50081-1 (B class) → EN61000-6-3 :02

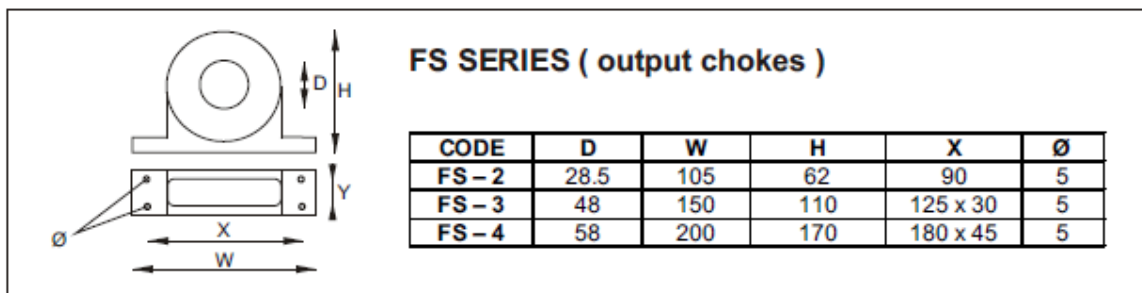

## DIMENSIONS

### FF SERIES ( Footprint )

FIG. A

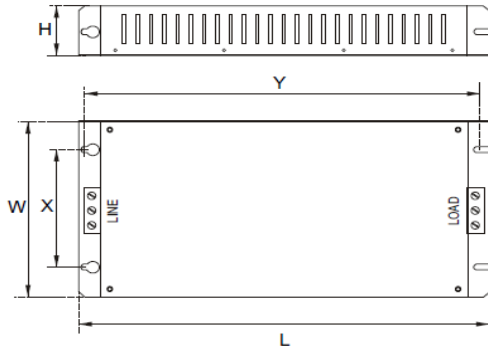

### FE SERIES ( Standard )

FIG. B

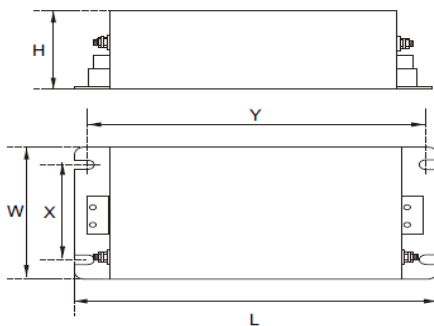
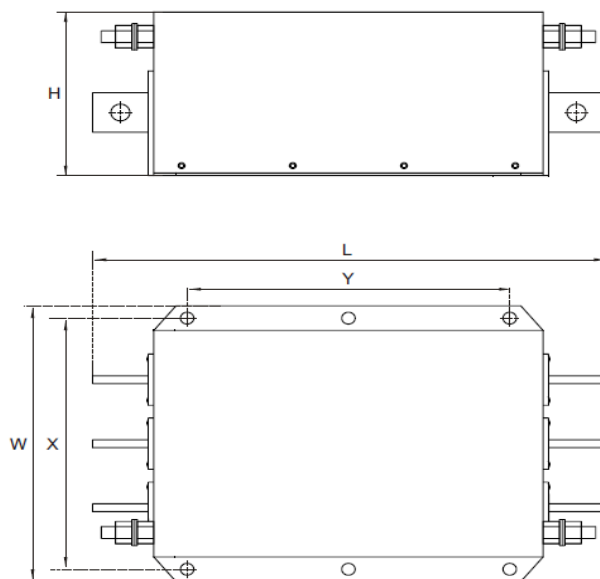

FIG.C



VECTOR MOTOR CONTROL IBÉRICA S.L.  
C/ Mar del Carib, 10 - Polígono Industrial La Torre del Rector  
08130 Santa Perpètua de Mogoda - BARCELONA (ESPAÑA)  
Tel. (+34) 935 748 206 - Fax (+34) 935 748 248 - info@vmc.es

[www.vmc.es](http://www.vmc.es)



## UL mark



The UL mark applies to products in the United States and Canada. This mark indicates that UL has tested and evaluated the products and determined that the products satisfy the UL standards for product safety. If a product received UL certification, this means that all components inside the product had been certified for UL standards as well. Suitable for Installation in a Compartment Handling Conditioned Air

## CE mark



The CE mark indicates that the products carrying this mark comply with European safety and environmental regulations. European standards include the Machinery Directive for machine manufacturers, the Low Voltage Directive for electronics manufacturers and the EMC guidelines for safe noise control.

### **Low Voltage Directive**

We have confirmed that our products comply with the Low Voltage Directive (EN 61800-5-1).

### **EMC Directive**

The Directive defines the requirements for immunity and emissions of electrical equipment used within the European Union. The EMC product standard (EN 61800-3) covers requirements stated for drives.

## EAC mark



The EAC (EurAsian Conformity) mark is applied to the products before they are placed on the market of the Eurasian Customs Union member states.

It indicates the compliance of the products with the following technical regulations and requirements of the Eurasian Customs Union:

Technical Regulations of the Customs Union 004/2011 "On safety of low voltage equipment"

Technical Regulations of the Customs Union 020/2011 "On electromagnetic compatibility of technical products"

# Warranty

<b>Maker</b>	<b>LS ELECTRIC Co., Ltd.</b>		<b>Installation (Start-up) Date</b>	
<b>Model No.</b>	<b>SV-iV5 New Controller</b>		<b>Warranty Period</b>	
<b>Customer Information</b>	Name			
	Address			
	Tel.			
<b>Sales Office (Distributor)</b>	Name			
	Address			
	Tel.			

This product has been manufactured through a strict quality management and inspection process by LS Technical Team. The warranty period is 18 months from the date manufactured, provided that, the warranty period is subject change depending on the terms and condition of the agreement under separate cover.

## FOC Service

If there is any failure in the product during the afore-mentioned warranty period you can have it repaired FOC by requesting our distributor or designated service center subject that you are found to have used it under our recommended environment. For further details, please refer to our company's regulation.

## Charged Service

- In the event of any of the following cases, the service will be charged.
  - The failure occurred from the consumer's improper storage, handling, and careless handling
  - The failure occurred from the consumer's error in the design of software or hardware
  - The failure occurred from the error of power source and the defect of the connector
  - The failure occurred from the force majeure (fire, flood, gas disaster, earthquake, etc.)
  - The product was modified or repaired at the discretion of the consumer in the place other than our Distributor or the Service Center.
  - The name plate provided by LS is not attached on the product
  - The product was used in an improper way or beyond the operating range.
- Repair Warranty Period for the Discontinued Model
  - For the product discontinued, the repair service will be provided with charge for five years from the date discontinued.

### ■ Waiver of the warranty for the mechanical loss, etc.

LS ELECTRIC Co., Ltd. doesn't bear any responsibility to indemnify indirect, special, incidental, or consequential loss (including the indemnification of sales loss, loss profit, etc.

## Revision History

No.	Date	Edition	Changes
1	July, 2011	First Release	New controller ver. 3.00 released
2	April, 2013	2 <sup>nd</sup> Edition	Ver. 3.20 / Short floor operation, Profibus data Swap function added
3	May, 2020	3 <sup>rd</sup> Edition	Change LSIS -> LS ELECTRIC

### Environment management

LS ELECTRIC regards the environmental preservation as a high priority, and all our employees do our best for the environmental preservation fresh earth.

### Disposable product

LS inverter is designed for preserving environment.  
When you disuse the products, you can recycle by separating them to iron, aluminum, bronze, and synthetic plastic (cover).



[www.lselectric.co.kr](http://www.lselectric.co.kr)

## LS ELECTRIC Co., Ltd.

### ■ Headquarter

LS-ro 127(Hogye-dong) Dongan-gu, Anyang-si, Gyeonggi-Do, 14119, Korea

### ■ Seoul Office

LS Yongsan Tower, 92, Hangang-daero, Yongsan-gu, Seoul, 04386, Korea

Tel: 82-2-2034-4033, 4888, 4703 Fax: 82-2-2034-4588

E-mail: [automation@lselectric.co.kr](mailto:automation@lselectric.co.kr)

### ■ Overseas Subsidiaries

#### • LS ELECTRIC Japan Co., Ltd. (Tokyo, Japan)

Tel: 81-3-6268-8241 E-Mail: [jschuna@lselectric.biz](mailto:jschuna@lselectric.biz)

#### • LS ELECTRIC (Dalian) Co., Ltd. (Dalian, China)

Tel: 86-411-8730-6495 E-Mail: [jiheo@lselectric.com.cn](mailto:jiheo@lselectric.com.cn)

#### • LS ELECTRIC (Wuxi) Co., Ltd. (Wuxi, China)

Tel: 86-510-6851-6666 E-Mail: [sblee@lselectric.co.kr](mailto:sblee@lselectric.co.kr)

#### • LS ELECTRIC Vietnam Co., Ltd.

Tel: 84-93-631-4099 E-Mail: [jhchoi4@lselectric.biz](mailto:jhchoi4@lselectric.biz) (Hanoi)

Tel: 84-28-3823-7890 E-Mail: [sjbaik@lselectric.biz](mailto:sjbaik@lselectric.biz) (Hochiminh)

#### • LS ELECTRIC Middle East FZE (Dubai, U.A.E.)

Tel: 971-4-886-5360 E-Mail: [salesme@lselectric.biz](mailto:salesme@lselectric.biz)

#### • LS ELECTRIC Europe B.V. (Hoofddorf, Netherlands)

Tel: 31-20-654-1424 E-Mail: [europartner@lselectric.biz](mailto:europartner@lselectric.biz)

#### • LS ELECTRIC America Inc. (Chicago, USA)

Tel: 1-800-891-2941 E-Mail: [sales.us@lselectricamerica.com](mailto:sales.us@lselectricamerica.com)

### ■ Overseas Branches

#### • LS ELECTRIC Tokyo Office (Japan)

Tel: 81-3-6268-8241 E-Mail: [jschuna@lselectric.biz](mailto:jschuna@lselectric.biz)

#### • LS ELECTRIC Beijing Office (China)

Tel: 86-10-5095-1631 E-Mail: [khpaek@lselectric.com.cn](mailto:khpaek@lselectric.com.cn)

#### • LS ELECTRIC Shanghai Office (China)

Tel: 86-21-5237-9977 E-Mail: [tsjun@lselectric.com.cn](mailto:tsjun@lselectric.com.cn)

#### • LS ELECTRIC Guangzhou Office (China)

Tel: 86-20-3818-2883 E-Mail: [chenxs@lselectric.com.cn](mailto:chenxs@lselectric.com.cn)

#### • LS ELECTRIC Chengdu Office (China)

Tel: 86-28-8670-3201 E-Mail: [yangcf@lselectric.com.cn](mailto:yangcf@lselectric.com.cn)

#### • LS ELECTRIC Qingdao Office (China)

Tel: 86-532-8501-2065 E-Mail: [wangzy@lselectric.com.cn](mailto:wangzy@lselectric.com.cn)

#### • LS ELECTRIC Nanjing Office (China)

Tel: 86-25-8467-0005 E-Mail: [ylong@lselectric.com.cn](mailto:ylong@lselectric.com.cn)

#### • LS ELECTRIC Bangkok Office (Thailand)

Tel: 66-90-950-9683 E-Mail: [sjleet@lselectric.biz](mailto:sjleet@lselectric.biz)

#### • LS ELECTRIC Jakarta Office (Indonesia)

Tel: 62-21-2933-7614 E-Mail: [dioh@lselectric.biz](mailto:dioh@lselectric.biz)

#### • LS ELECTRIC Moscow Office (Russia)

Tel: 7-499-682-6130 E-Mail: [jdpark1@lselectric.biz](mailto:jdpark1@lselectric.biz)

#### • LS ELECTRIC America Western Office (Irvine, USA)

Tel: 1-949-333-3140 E-Mail: [vwun@lselectricamerica.com](mailto:vwun@lselectricamerica.com)

10310001225

### Disclaimer of Liability

LS ELECTRIC has reviewed the information in this publication to ensure consistency with the hardware and software described. However, LS ELECTRIC cannot guarantee full consistency, nor be responsible for any damages or compensation, since variance cannot be precluded entirely. Please check again the version of this publication before you use the product.

© LS ELECTRIC Co., Ltd 2020 All Right Reserved.

SV-IV5 / 2020.05

