

Synchronous Serial Interface Module

FBs-3SSI is one of the special function modules of FATEK FBs series PLC. By applying the FBs-3SSI module, the FBs PLC can read out the position data generated by the absolute position sensing device which has the Synchronous Serial Interface (SSI). SSI interface is driven by the digital differential signal which can reduce the possibility of error occurrences caused by the interference of electric noise.

1 Specifications of FBs-3SSI Synchronous Serial Interface Module

FBs-3SSI Synchronous Serial Interface Module

Specifications	FBs-3SSI
Total Channel	3 channels
Clock Frequency	~ 200KHz
Data Update Rate	less than 2ms
Input Data Bit	MSB first, 12~32 bit length selectable
Input Data Encoding Format	Binary or Gray Code
Error Indication	Signal or wiring error(* ₁)
System Capability	up to 4 FBs-3SSI modules
Signal Isolation	Output: None Input: Opto-coupler
Indicators	power LED
Internal Power Consumption	5V, 100mA
Working Temperature	0 ~ 60 °C
Storage Temperature	-20 ~ 80 °C

2 The Procedures of Using FBs-3SSI Synchronous Serial Interface Module

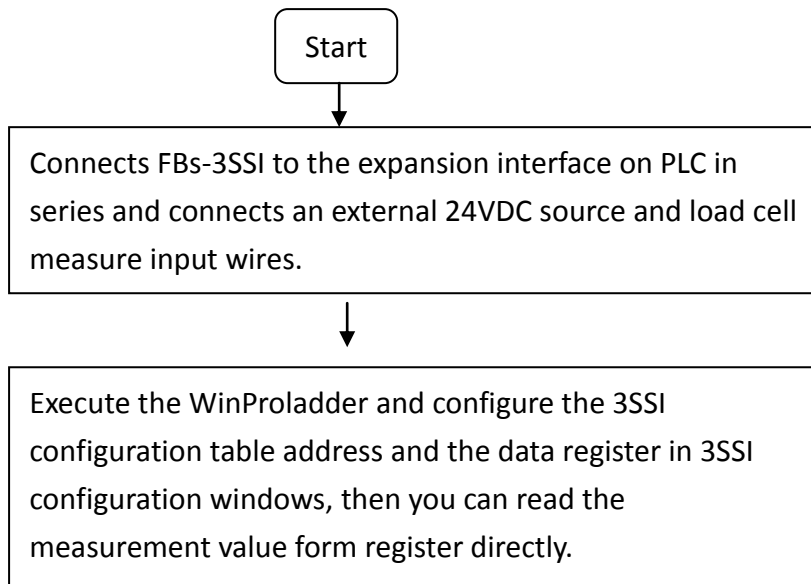

3 The Procedures of 3SSI Module

Click the item “I/O Configuration” which in Project Windows :

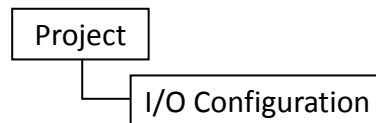

➔ Select “3SSI Configuration” :

Once the setting page displayed, is able to measure the 3SSI module.

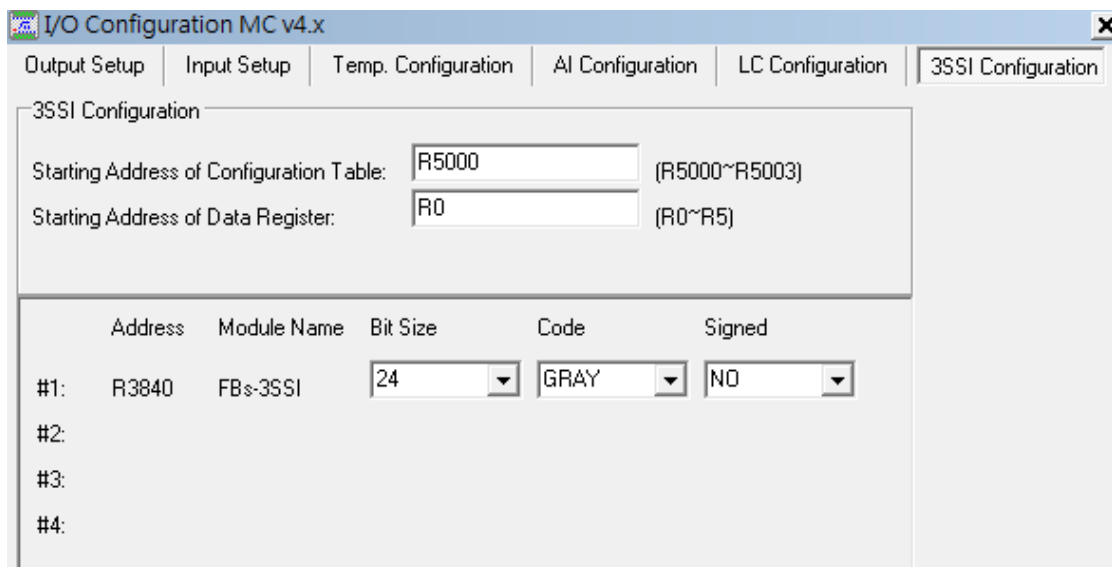

1. [Starting Address of Configuration Table] :

The content of 3SSI configuration requires 4 consecutive registers; please enter the configuration registers for this purpose in the first register.

Assign a starting register value to store the 3SSI configuration table, there will allow the following inputs:

RXXXX or DXXXX

The configuration table only occupies 3+N of registers, where N is the number of 3SSI modules.

As shown in the above example, R5000~ R5003 stores the 3SSI configuration table.

2. [Starting Address of Data Register] :

3SSI module reads the position sensor requires 6 consecutive data registers; please enter the configuration registers for this purpose in the first register.

Assign a data register to store the current 3SSI reading values, there will allow the following inputs, RXXXX or DXXXX

1 set of sensor reading occupies 2 registers

As shown in the above example, the reading value of the first sensor stores to DR0, the second sensor stores to DR2, and the third sensor stores to DR4

Notes: The above two settings can be used in all 3SSI modules.

If there is line broken happened, the broken value 40000000H will be displayed.

【3SSI installation information and setup】

3. [Module #1 ~ #4] :

Display the name of the installed module and the analog starting address of its own

4. [Bit Size] : It means the sensor's data bit size. The input range is 12~32.

Please note that, no matter the bit size is less than or equal to 16, each channel occupies 2 registers.

5. [Code] : Sensor output encoding format. Can choose GRAY (GRAY code) or BINARY (binary code). You must correctly select the corresponding output coding format because from that, it then can obtain the correct value from the register.

6. [Signed] : Sensor output data with or without positive or negative sign. If the sensor output with positive sign then select YES, with negative sign then select NO. Usually is NO.

4 I/O Addressing of 3SSI Module

By the time domain multiplexing design method, each 3SSI module occupies 1 point of input register and 8 points of digital output for I/O addressing. For correct I/O access, the I/O addressing of extension modules following the 3SSI module must be added the I/O quantity which the corresponding module should have. The WinProLadder provides an easy and convenient way to calculate the I/O address for the extension modules through the on-line "I/O Numbering" operation.

5 3SSI Module outline and signal description

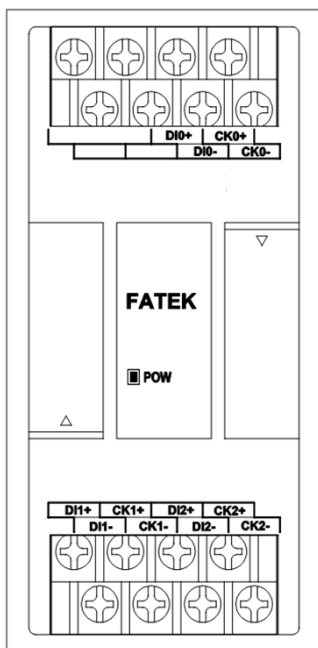

Signal Name	Description
DI0+,DI1+,DI2+	Channel 0,1,2 data +
DIO-,DI1-,DI2-	Channel 0,1,2 data -
CK0+,CK1+,CK2+	Channel 0,1,2 clock +
CK0-,CK1-,CK2-	Channel 0,1,2 clock -

6 Wiring of 3SSI Module

