

FATEK

FBS-1HLC

Precision Load Cell Module

Operation manual

V1.1

06/07/2017

FATEK AUTOMATION CORP.

Contents

Chapter 1	1HLC module introduction	3
1.1	Module specification.....	3
1.2	Module appearance and description	4
1.3	Application connections.....	4
1.4	Communication interface between 1HLC and PLC:	6
1.5	1HLC application interface	6
1.5.1	Application interface contents and Modbus comparison table	6
1.5.2	Detailed description.....	7
Chapter 2	Application examples	8
2.1	Application connections.....	8
2.2	Setting PLC communication parameters	8
2.3	Ladder diagram programming	9
2.4	1HLC module calibration	10
2.4.1	Zero-point calibration.....	10
2.4.2	Full-span calibration	10
2.4.3	Weight measuring	10

Chapter 1 1HLC module introduction

A load cell is formed by attaching a stress strain gauge to a metal elastic body. When the metal elastic body is subjected to pressure or tensile force, the deformation of the elastic body is detected and converted to an output voltage signal. PLC acquires data from 1HLC via the Modbus communication protocol.

1.1 Module specification:

General specification	
Supply voltage	DC 24V
Weight	127g
Operation temperature	-10°C to + 40°C (+14°F to + 104°F)
Operation humidity	85% relative humidity (non-condensing state)
Dimensions	90 (L) x 40 (W) x 80 (H) mm
Input signal and A/D conversion	
Resolution	16Bits
A/D conversion speed	100 times/sec
Load cell excitation power supply	DC 5V \pm 5% , 120mA (for 8 350 Ω load cells)
Max. measured voltage	-1mV ~ 39mV
Input sensitivity/resolution	Above 0.15 μ V/D 1 / 60000 d
Digital	
Status indicators	POWER · MD · ZERO · NET · GROSS
Memory	Calibration parameters and function settings are all saved to EEPROM
Features	
1. Industrial-grade weight control design suitable for all kinds of extreme industrial environments	
2. High noise-interference resistance; effectively suppresses interferences from power supplies, electromagnetic waves, and wireless RF.	
3. Small volume and occupies little space; convenient for storage in control stations, high precision, and superior performances	
4. Adjustable digital filtering may effectively suppress vibrations generated in local environment	
5. Flexible calibration schemes and automatic stability detection	
6. Automatic zero-point tracking for effective suppressing of zero-point drift occurring in load cells	

1.2 Module appearance and description

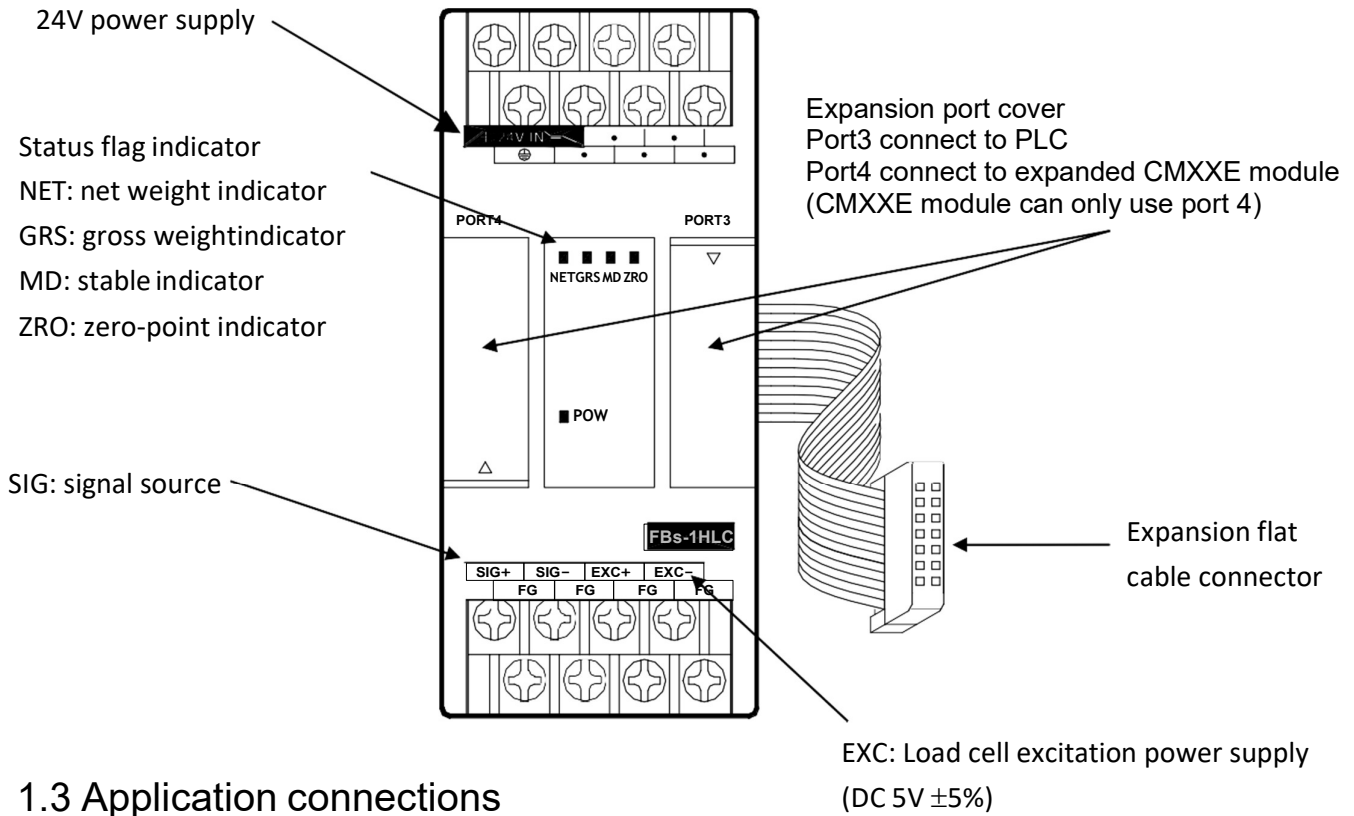

1.3 Application connections

Four-line connection

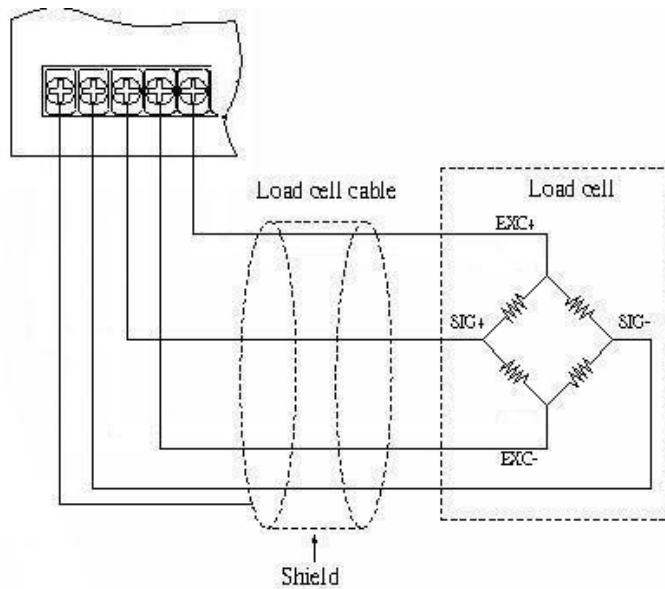

Six-line connection

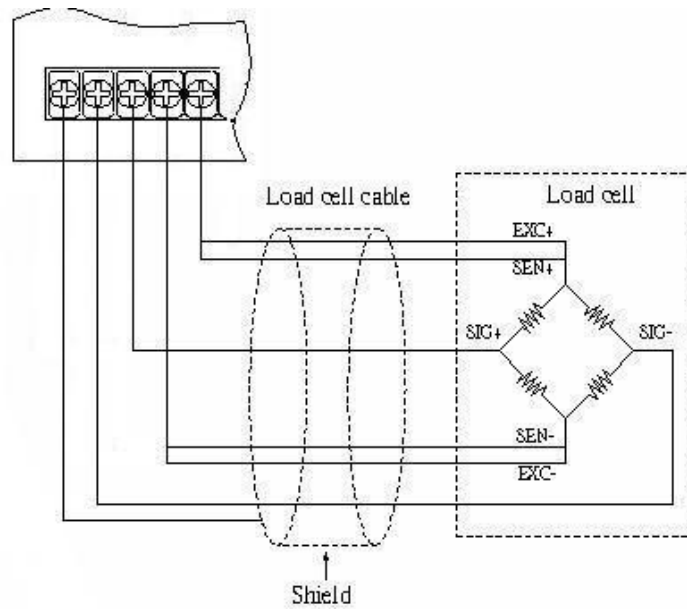

Multiple-load-cell connection

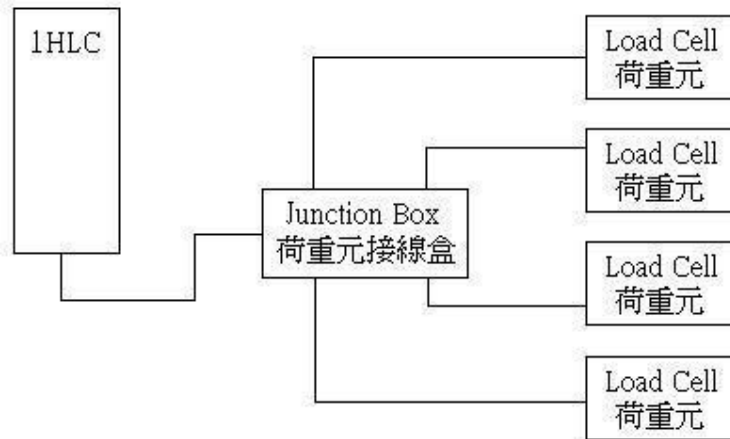

1.4 Communication interface between 1HLC and PLC:

PLC acquires data from 1HLC via the Modbus communication protocol.

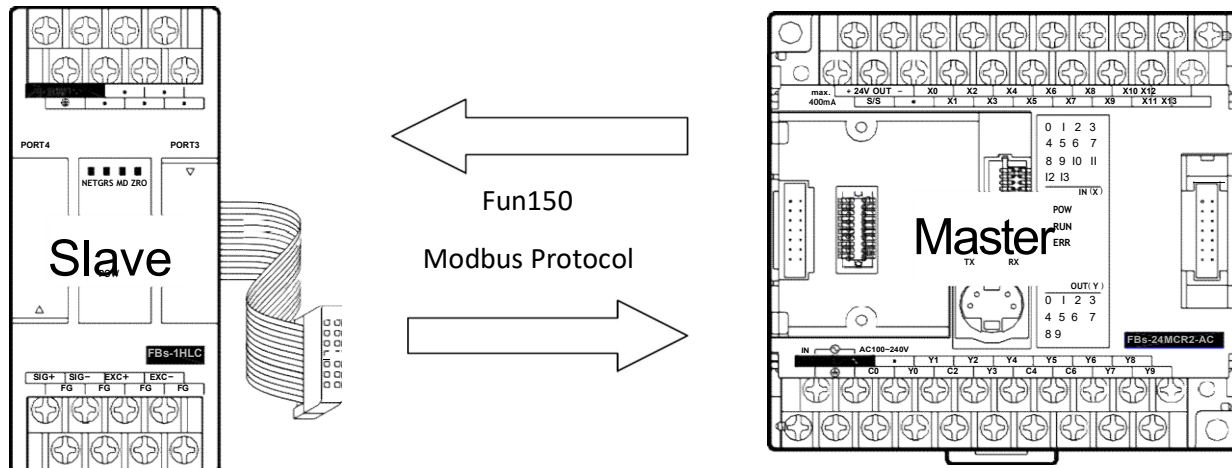

Connect to PLC using Winproladder and change the PORT 3 communication parameters of Winproladder. The communication parameters of 1HLC are fixed as follow:

PORT	Connection speed	Parity bit	Data bit	Stop bit	format
Port3	19200	No	8	1	RTU

1.5 1HLC application interface:

1.5.1 Application interface contents and Modbus comparison table

Status/Control bit

Address	Name	Length	R/W
000002	Overload flag	Bit	R
000005	Display gross weight flag	Bit	R
000006	Display net weight flag	Bit	R
000007	Zero-point flag	Bit	R
000008	Unstable flag	Bit	R
000257	Adjust to zero	Bit	W
000258	Deduction	Bit	W
000263	Clear deduction	Bit	W
000513	Zero-point calibration input	Bit	W
000514	Full-span calibration input	Bit	W
000773	Save EEP	Bit	W

Status/Settings register

Address	Name	Settings	Length	R/W
402305	AD internal value		Word	R
402307	Display value		2Word	R
402567	SPAN calibration weight		2Word	R/W
402561	Max. weight		2Word	R/W
401793	Calibration error message	0~3	Word	R/W
402049	AD sampling frequency	0=100、1=50、2=25、3=12.5、4=6.25Hz	Word	R/W
402052	Min. scale	1,2,5,10,20,50	Word	R/W

1.5.2 Detailed description

Status/Control bit

Address	Name	Description
000002	Overload flag	Flag ON when the measured weight is higher than the max. weight
000005	Display gross weight flag	Displayed measurement value includes package weight
000006	Display net weight flag	Displayed measurement value is actual weight
000007	Zero-point flag	Gross weight is 0 when=1
000008	Unstable flag	Conditions of unstable tracking time and unstable tracking area may be set for the devices maintaining stable values
000257	Adjust to zero	Function to set or adjust the displayed value to zero when there is no load when=1
000258	Deduction	Deduce the package weight of the load on the tray when=1
000263	Clear deduction	Clear the package weight deduction and display gross weight when=1
000513	Zero-point calibration input	Zero-point button to be set during calibration when=1
000514	Full-span calibration input	SPAN weight button to be set during calibration when=1 (SPAN calibration weight should be set first)
000773	Save EEP	Save settings in EEPROM and automatically read previously saved settings at power-on when=1

Status/Settings register

Address	Name	Description
402305	AD internal value	Value of scale analog signal voltage converted for internal calculations of the scale.
402307	Display value	Actual measured weight after specification calibration and weight calibration.
402567	SPAN calibration weight	Weight of known standardized weight in calibration.
402561	Max. weight	Set maximum weight of scale and display overload flag if exceeding the max. weight.
401793	Calibration error message	0 : normal 1 : AD abnormal 2 : weight calibration earlier than prerequisite calibration (e.g., SPAN1<ZERO) 3 : weight calibration precision higher than 0.1uV/D

Chapter 2 Application examples

2.1 Application connections

Complete the hardware wiring connection first; please refer to the hardware equipment and connection scheme in below.

Hardware: FBs-24MC*1, FBs-1HLC*1, and scale*1

1. Connect 1HLC cable to the left (communication) expansion port of PLC.
2. The 4 lines of the scale are connected to EXC+, EXC-, SIG+, and SIG- of 1HLC.

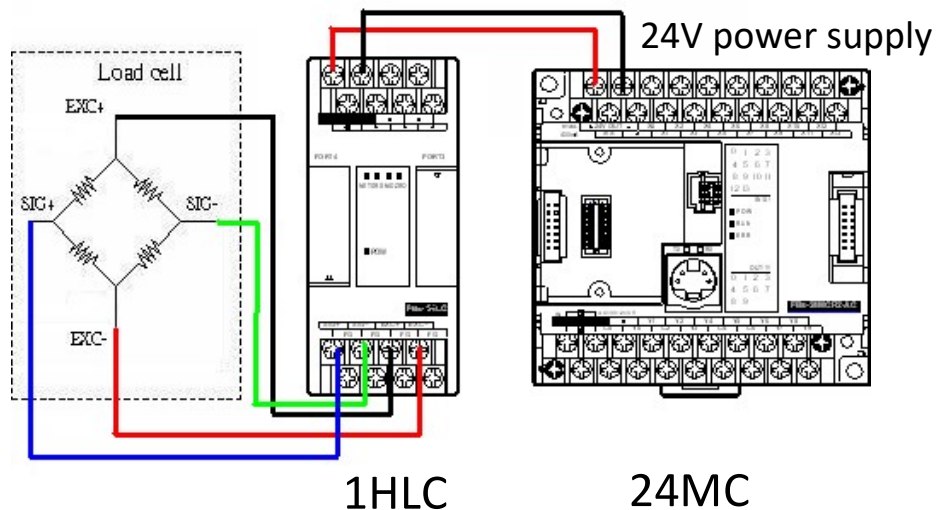

2.2 Setting PLC communication parameters

Connect to PLC using Winproladder (24MC in this example) and change the PORT 3 communication parameters of Winproladder. The communication parameters of 1HLC are fixed as follow:

PORT	Connection speed	Parity bit	Data bit	Stop bit	format
Port3	19200	No	8	1	RTU

2.3 Ladder diagram programming

1. Establish FUN150 in the ladder diagram of Winproladder and use FUN150 Modbus to transmit data from 1HLC.

Use X0 to control M102 and X1 to control M103 because M102 is the zero-point calibration control coil (000513) and M103 is the full-span calibration control coil (000514) from the Modbus Master table in step 2.



2. Register addresses to be read or written are set in the Modbus Master table; for the register addresses of the slave please refer to 【 1.5.1 Application interface contents and Modbus comparison table 】 .

筆數	命令	備站	主站資料	備站資料	長度	
0	讀取(Read)	1	R500	<<	402307	2
1	單個寫入(write)	1	M100	->	000257	1
2	單個寫入(write)	1	M101	->	000258	1
3	單個寫入(write)	1	M102	->	000513	1
4	單個寫入(write)	1	M103	->	000514	1
5	單個寫入(write)	1	M104	->	000263	1
6	讀取(Read)	1	M105	<<	000005	1
7	讀取(Read)	1	M106	<<	000006	1
8	讀取(Read)	1	M107	<<	000007	1
9	讀取(Read)	1	M108	<<	000008	1
10	寫入(write)	1	R502	->	402561	2
11	寫入(write)	1	R504	->	402567	2
12	讀取(Read)	1	R506	<<	401793	1
13	讀取(Read)	1	R508	<<	402305	2

設定: 動態配置[2840]字組 資料長度: 101 字組 配置位置: R1000-R1100

2.4 1HLC module calibration

Module calibration allows the subsequently measured values to be more precise. The registers and connections in the calibration steps have already been converted by step 2 **【Modbus Master Table】** in section 2.3 and the detailed corresponding registers are described in this section.

2.4.1 Zero-point calibration

Confirm that the tray or tank scale is empty and execute zero-point calibration input (X0 from 0 to 1); if successful, the display value register DR500 (Modbus register 402307) will be zero. If not, confirm whether the zero-point calibration operation is correct. Subsequently, set the status of X0 of zero-point calibration back to 0 or else the display value will remain at 0 when measuring.

2.4.2 Full-span calibration

Place object of known weight (standardized weight) on the tray or tank scale and input the weight of the object of known weight to the SPAN calibration weight register DR504 (Modbus register 402567); after the displayed value is stable, execute SPAN calibration input (X1 from 0 to 1). The display value register DR500 (Modbus register 402307) will be the same as DR504 (Modbus register 402567). Subsequently, set X1 from 1 to 0 and remove the object of known weight (standardized weight); measurements of objects may then begin.

Note: if register DR504 (Modbus register 402567) is zero then the display value register DR500 (Modbus register 402307) will remain zero when measuring weights.

2.4.3 Weight measuring

Place object on the tray and the display value register DR500 (Modbus register 402307) will display the weight of the object according to the standard of the known weight in full-span calibration.