



Digitized Automation for a Changing World

Delta Door Control Drive & Motor VFD-DD Series



Door Drive Functions and Features

User Friendly Design



Door Control Solutions

• Distance Control Mode

For encoder applications this mode precisely controls the door's opening and closing position via encoder feedback signal.

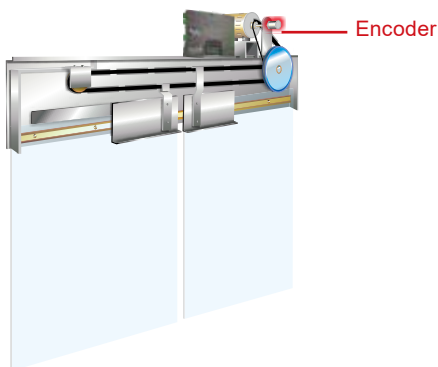

• Speed Control Mode

For induction motor applications this mode executes door opening and closing via 2~4 limit sensors or switch sensors.

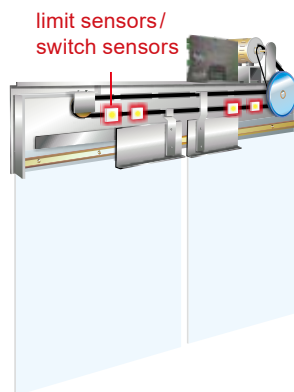

• Multi-step Speed Control Mode

For PLC applications this mode uses Delta's PLC as a host controller to control door opening and closing in multi-step speeds.

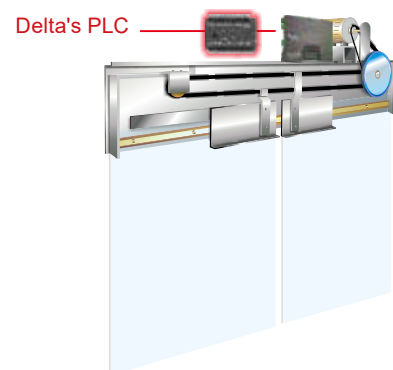

Built-in Door Control Functions

- **Door Width Auto-tuning**

Door width is automatically measured and saved as the door opens and closes. It will open and close twice to confirm the door width accuracy. Once confirmed, the measurement is recorded into the drive parameters.

- **Smooth Door Curve**

The door will reopen in a reverse direction when door blockage is detected. The reopen is performed with a smooth curve to minimize the impact of vibration.

- **Demo Mode**

Demo mode demonstrates the door open, close and reverse motions to ensure the performance and quality of the drive system and the door structure.

- **Asynchronous (IM) and Synchronous (PM) Motors Applications**

Compatible with Delta ECMD series door control servo motor and other induction motors (signal type encoder that accepts open collector and differential signal with 5, 12 or 24 V_{DC}).

- **Door Protection System**

Passengers enter and exit the elevator with greater safety. When the light curtain and safety panel fail to function, the drive will command the door to re-open as it detects a rise of current caused by the blocked door.

- **Blockage Detection**

- Precise torque detection at blockage
- Door remains at current position for a few seconds
- Door "OPEN/CLOSE" time-out
- Forced open

- **Built-in EMI Filters**

(except for Basic Models)

Specifications

230V 1-phase: 200W and 400W models				
Model Number VFD-___DD	001	002	004	
Max.Applicable Motor Output (W)	100	200	400	
Output Rating	Rated Output Current (A)	0.3	1.0	
	Rated Output Current for Constant Torque (A)	0.8	2.5	
	Maximum Output Voltage (V)	Proportional Double Input Voltage	Proportional Input Voltage	
	Output Frequency (Hz)	0.00 ~ 120.00		
	Carrier Frequency (kHz)	10		
	Rated Input Current (A)	3	4.9	6.5
Environment	Voltage Tolerance (V)	Single Phase 100 ~ 120 (-15 ~ +10%) (85 ~ 132)	Single Phase 200 ~ 240 (-20 ~ +10%) (160 ~ 264)	
	Frequency Tolerance (Hz)	50/60 ± 5% (47 ~ 63)		
Cooling Method	Natural Cooling			
Frame (mm)	215 (W) × 170 (H) × 55 (D)			

General Specifications

Control Mode		V/F · VF+PG · SVC · FOC+PG · PMFOC+PG	
Control Features	Starting Torque	At 0.5Hz, starting torque reaches above 150% at 0.5Hz; under FOC+PG mode, starting torque reaches above 150% at 0Hz	
	Speed Control Range	1: 100 (external PG installation can achieve 1: 1,000)	
	Speed Control Accuracy	± 0.5% (external PG installation can achieve 0.02%)	
	Speed Response Ability	5Hz (vector control can attain 30Hz)	
	Max. Output Frequency	0.00 to 120.00Hz	
	Output Frequency Accuracy	Digital command ±0.005%	
	Frequency Setting Resolution	Digital command ±0.01Hz	
	Torque Limit	200% torque current as maximum	
	Accel/Decel Time	0.00 ~ 600.00sec	
	V/F Curve Pattern	Adjustable V/F curve of 4 independent points	
Operation Features	Frequency Setting Signal	Keypad	By parameter setting
		External Signal	Multi-function input selection 1~5 (16 steps; JOG), parameter setting on serial COM port (RS-485)
	Operation Setting Signal	Keypad	Set by OD, CD, STOP keys
		External Signal	2 wires (OD, CD), JOG operation, RS-485 serial COM port, demo mode
	Multi-Function Input Signal	Multi-step speed selection MI1~MI15, two steps accel/decel switches, JOG, demo mode, forced stop, emergency stop, operation command source, parameter lock, driver reset, open/close limit signal, open/close variable speed signal, door open prohibited signal, forced open signal, reposition, two steps accel/decel and high speed open/close switch	
Multi-Function Output Signal	(RC1, RA1, RB1), (RC2, RA2, RB2), (MO1, MO2, MO3 and MCM) AC drive operating, frequency attained, over torque, over voltage, operation mode, fault indication, alarm indication, demo mode indication, overheat alarm, drive is ready, emergency stop, braking signal, zero speed indication, PG error indication, position detection, limit signal, reopen/ close indication, position finished		
Communication Interface		Built-in Modbus, customized CAN bus	
Alarm Output Contact		Contact "ON" when malfunctions occur (relay with a "C" or "A" contact, or 2 open collector outputs)	
Operation Function		AVR, 6 sets of fault records, door open prohibition, DC brake, auto torque compensation, slip compensation, motor parameter auto-tuning, adjustable carrier frequency, output frequency upper and lower limits, parameter rest, vector control, Modbus communication, anomaly rest, anomaly restart, PG feedback control, fan mode selection, demo mode, door width auto-tuning	
Protection Function		Over-voltage, over-current, under current, external fault, motor overload, ground fault, drive overload, drive overheat, electronic thermal relay, PG feedback error, external limit signal error, door close anomaly protection	
Built-in Keypad		7 function keys, 4-digit 7-segment LED, 5 status LEDs; displays frequency command, actual output frequency, output current, user-defined units, parameter values for setup, review and faults, RUN, STOP, RESET, FWD/REV	
Built-in EMI filter		Certified to EN55011 CLASS A (Basic models excluded)	
Protection Features	Motor Protection	Electronic thermal relay protection	
	Over Current Protection	The current forces 180% of the over-current protection and 240% of the rated current	
	Overload Capacity	150% for 120 seconds; 180% for 10 seconds	
	Voltage Protection	Over-voltage level: $V_{DC} > 400V$; low-voltage level: $V_{DC} < 200V$	
	Over-voltage Protection for Input Power	Varistor (MOV)	
	Overheat Protection	Built-in temperature sensor	
Environment	Enclosure Rating	IP20	
	Operation Temperature	-10°C ~ 40°C	
	Ambient Temperature	-20°C ~ 60°C	
	Ambient Humidity	Below 90% RH (non-condensing)	
	Vibration	1.0 G, while frequency is less than 20Hz; 0.6G while frequency is between 20~60Hz	
	Installation Location	Altitude 1,000 m or lower, keep from dust, sunlight, corrosive and flammable gas	
Certification		UL, CE, *IEC61800-3	

** Input reactor is required to be compliant with EMC harmonic standards (IEC 61000-3-2 & 4)

Wiring

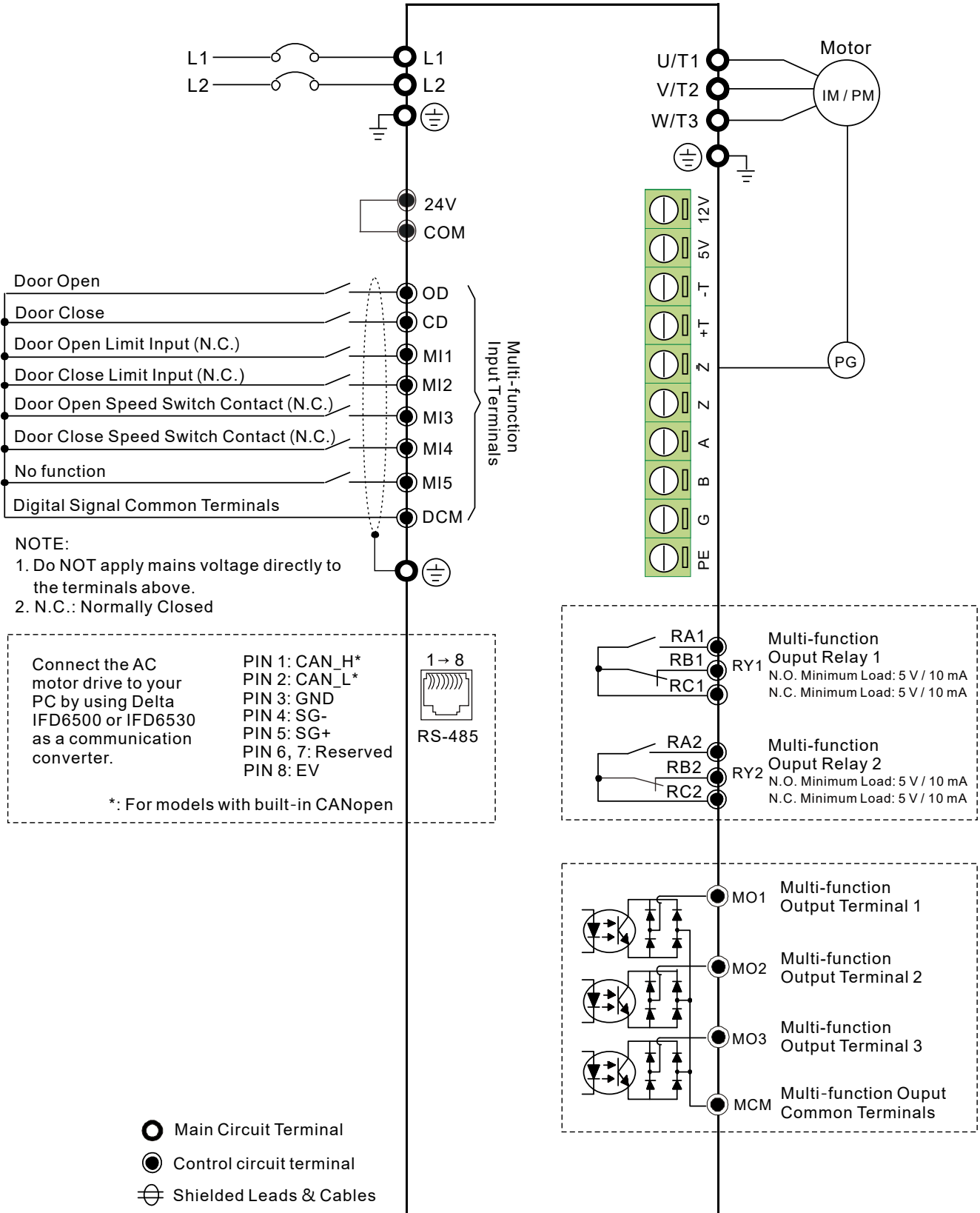

Dimensions

Frame A1

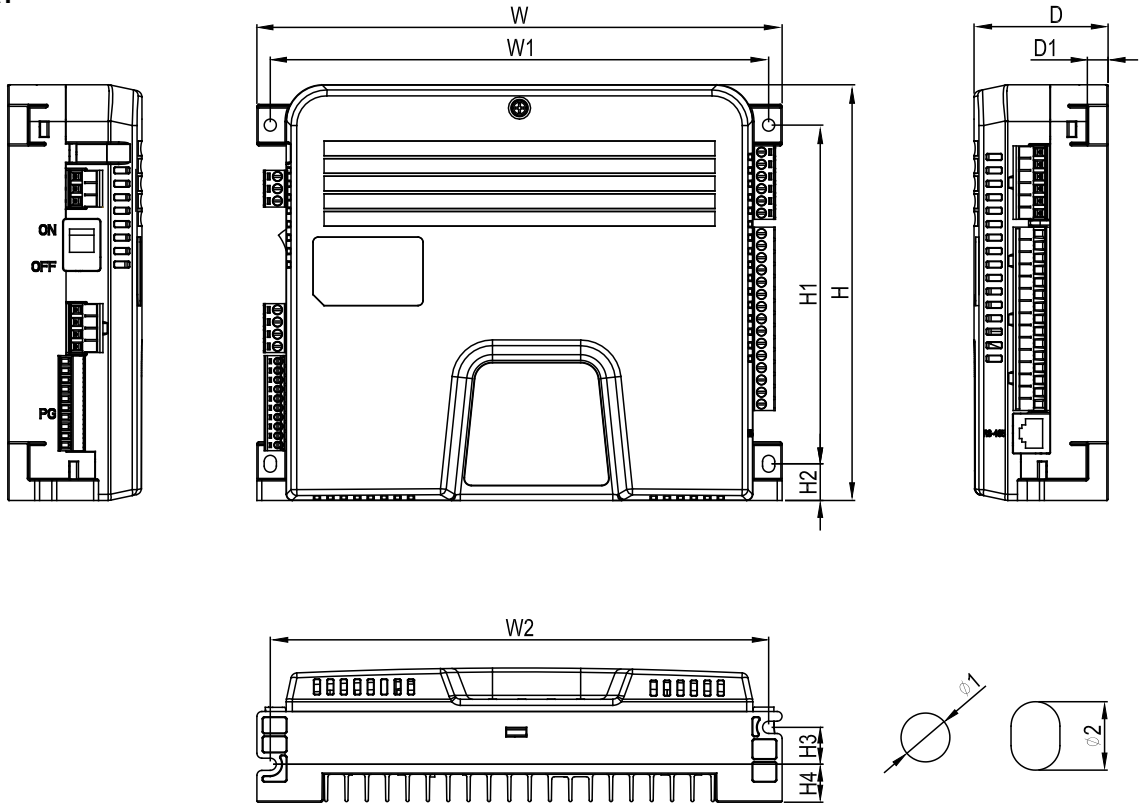

Model

VFD001DD11S
 VFD002DD21S
 VFD002DD21T
 VFD004DD21S
 VFD004DD21T
 VFD002DD21V
 VFD004DD21V

Frame		W	H	D	W1	W2	H1	H2	H3	H4	D1	Ø1	Ø2
A1	mm	215.0	170.0	55.0	204.0	204.0	138.5	15.0	15.1	15.5	8.5	5.0	7.0
	inch	8.46	6.69	2.17	8.03	8.03	5.45	0.59	0.59	0.61	0.34	0.20	0.28

Frame A2

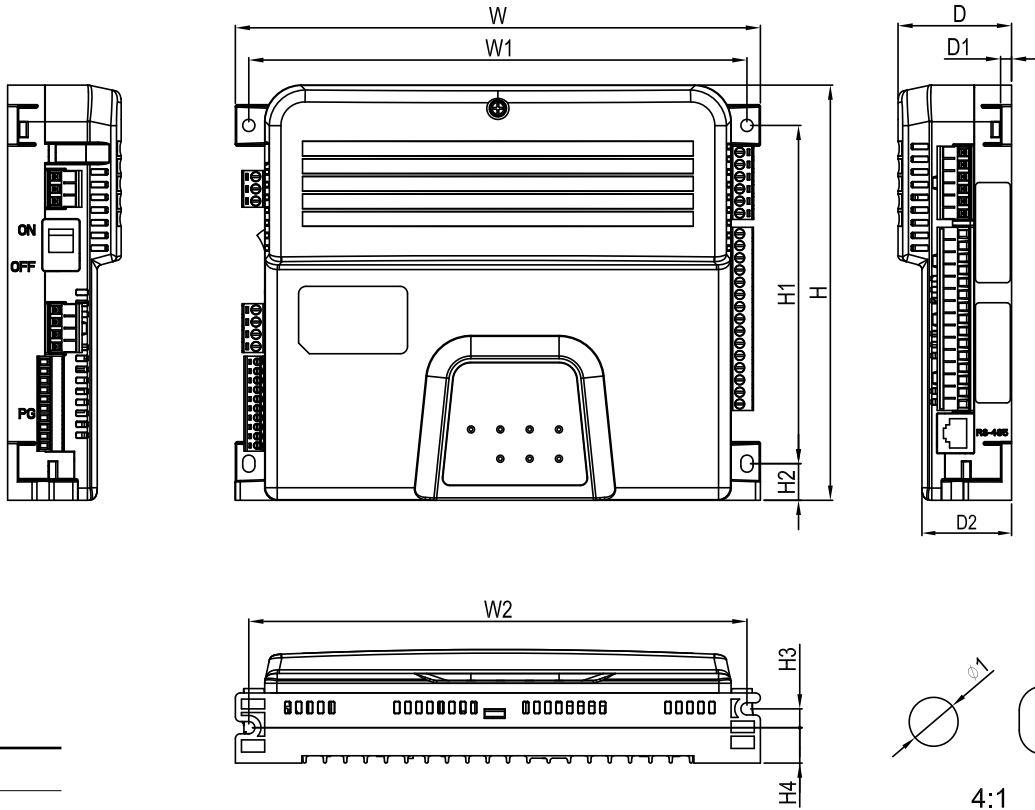

Model
VFD002DD21F

Frame	W	H	D	W1	W2	H1	H2	H3	H4	D1	Ø1	Ø2
A2	mm	215.0	170.0	46.5	204.0	204.0	138.5	15.0	7.7	14.5	4.5	5.0
	inch	8.46	6.69	1.83	8.03	8.03	5.45	0.59	0.3	0.57	0.17	0.28

Model Name of Door Drive

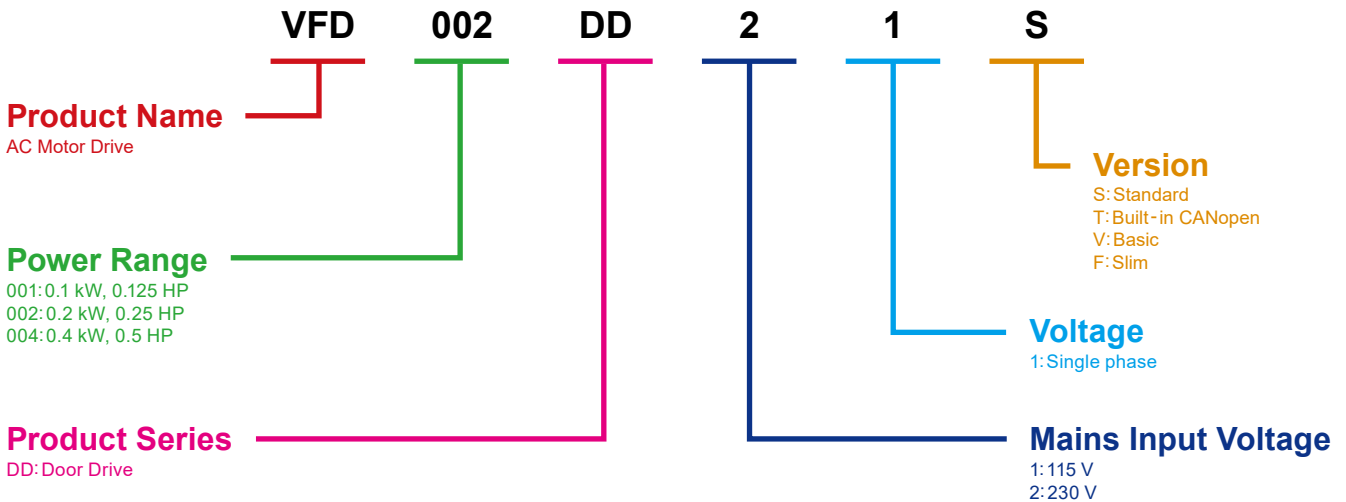

Servo Motors ECMD Series

- 55mm thin design
- Instant torque up to 5N-m
- Maximizes installation flexibility
Both sides of motor can be installed
- Motor temperature detection and overheating protection

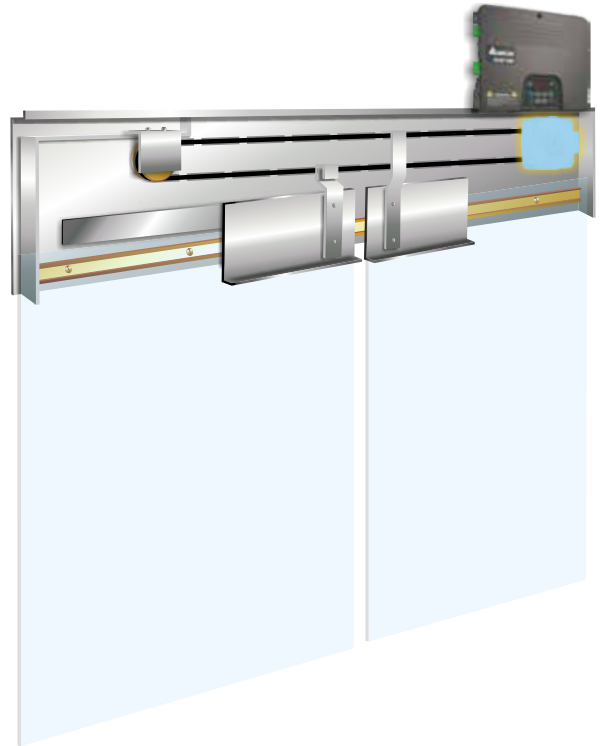

Specifications

Model		ECMD-B91207M_	ECMD-B91608M_	ECMD-B81610M_
Applicable DD Drive		100/200/400W	200/400W	200/400W
Rated	Rated Power (W)	70	80	100
	Rated Voltage (V)	220	220	220
	Rated Torque (N·m)	2.0	3.0	3.5
	Rated Speed (rpm)	350	250	280
	Rated Current (A)	0.7	1.0	0.95
Motor	Pole Numbers	10	16	16
	Encoder Resolution	10 bit (256ppr)	10 bit (256ppr)	12 bit (1024ppr)
	Continuous Torque (N·m)	2.0	3.0	3.5
	Instant Max. Torque (N·m)	5.0	5.0	5.5
	Max.Speed (rpm)	750	600	500
	Max.Instant Current (A)	2.5	2.5	2.5
	Rotor Moment of Inertia (Kg.m ²)	3.0×10^{-4}	4.9×10^{-4}	4.9×10^{-4}
	Armature Resistance (Ohm)	18.7	15.8	24.3
	Armature Inductance (mH)	195	177	273
	Mechanical Time Constant (ms)	1.96	2.42	2.13
	Electrical Time Constant (ms)	10.4	11.2	11.2
	Insulation Class	B		
	Insulation Resistance	10MΩ/500V _{DC}		
	Insulation Strength	1.5kV _{AC} /1 min.		
	Max. Radial Shaft Load (N)	98		
	Max. Thrust Shaft Load (N)	49		
	Weight (kg)	2.5	3.0	3.0
Environment	Maximum Winding Temperature (°C)	130		
	Operating Temperature (°C)	5 ~ 45		
	Storage Temperature (°C)	-10 ~ 50		
	Operating Humidity (%RH)	20 ~ 95 (Non-condensing)		
	Storage Humidity (%RH)	20 ~ 95 (Non-condensing)		
	IP Rating	IP20 (Standard)		

Dimensions

• ECMD - B91207MS

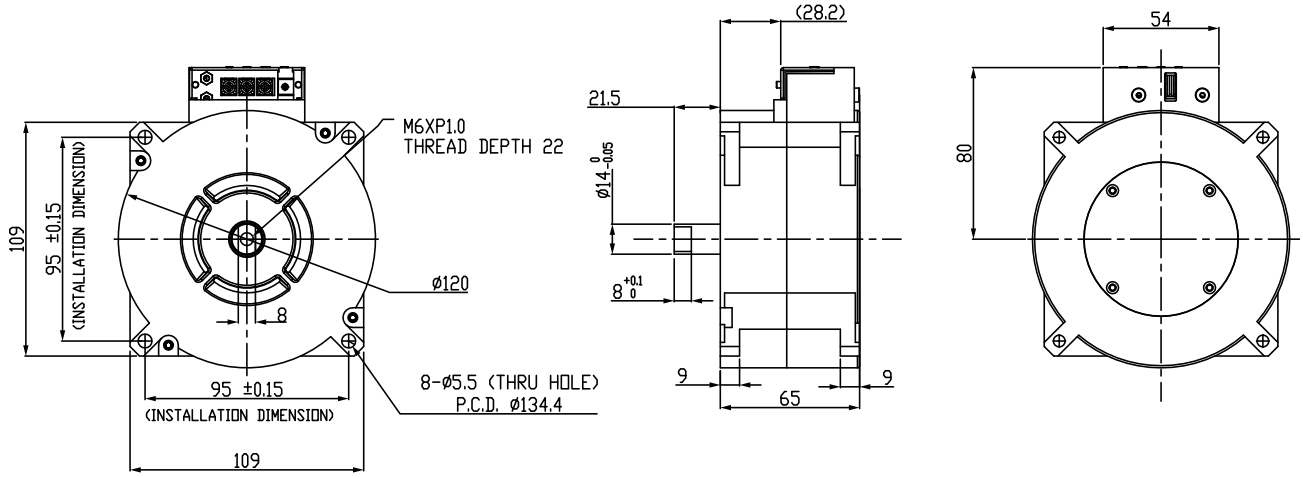

• ECMD - B91207MN

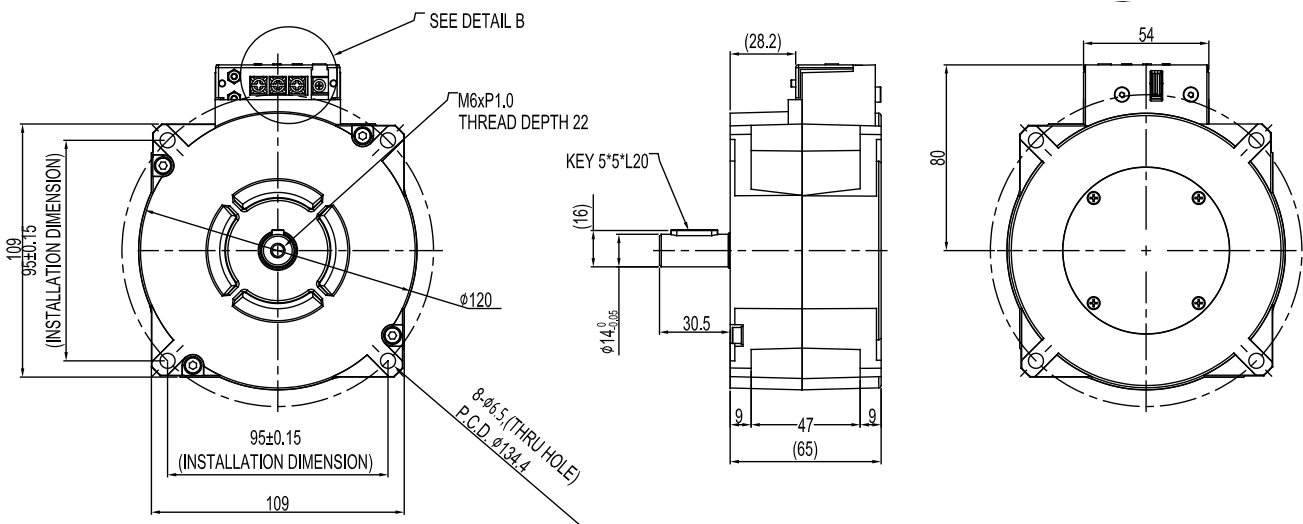

• ECMD - B91608MS / ECMD - B81610MS

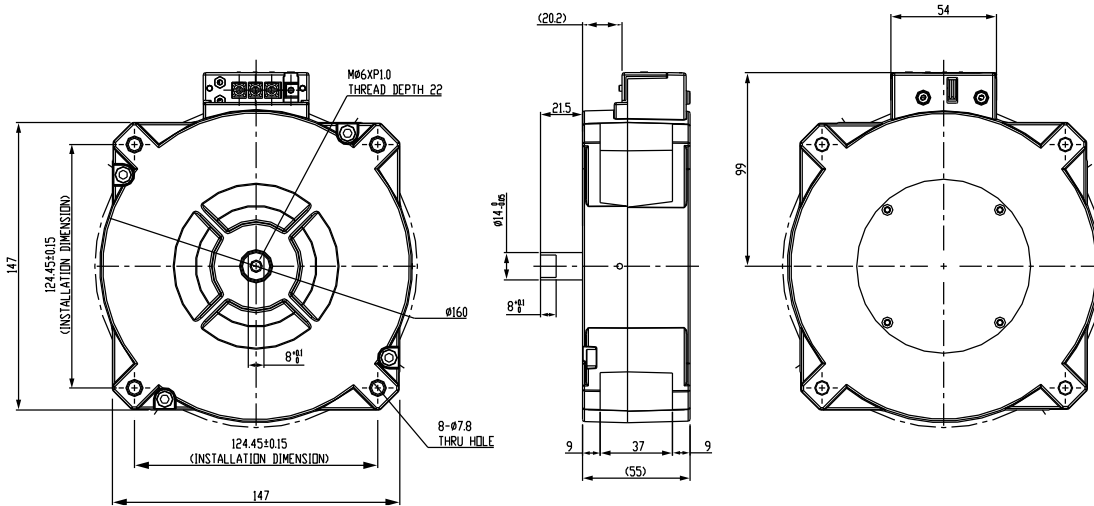

ECMD Motor Dust Cap

• ECMD Motor Dust Cap Installation

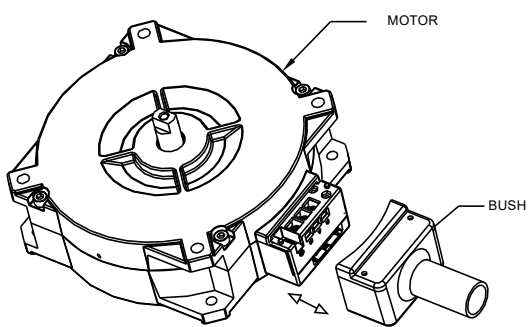

• ECMD Motor Dust Cap Specification

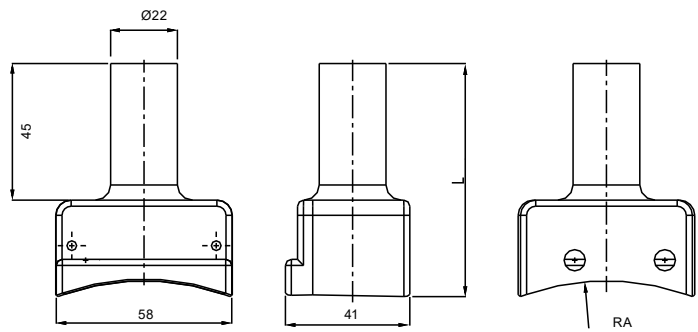

Model Name	L (mm)	RA (mm)	Motor
DPB - N7860	77.4	60	ECMD-B91207M_
DPB - N7779	76.8	79	ECMD-B81610M_ ECMD-B91608M_

Pin Definitions

• ECMD Motor Pin Definitions

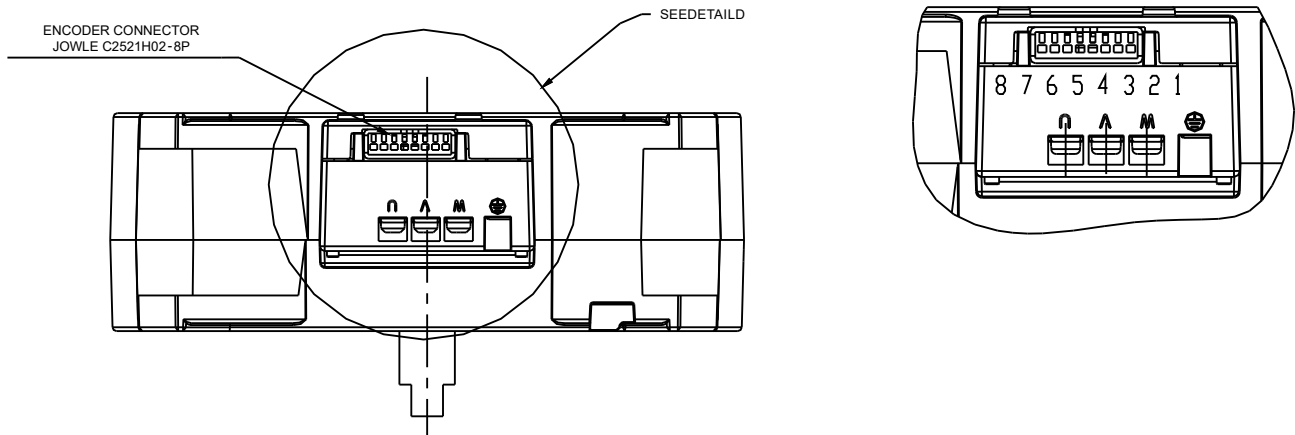

Pin No.	1	2	3	4	5	6	7	8
Function	A+	NTC+	B+	NTC-	PWM+	PWM-	+5V	GND

※ NTC function is under development.

• VFD-DD Pin Definitions of Encoder Feed back Terminal

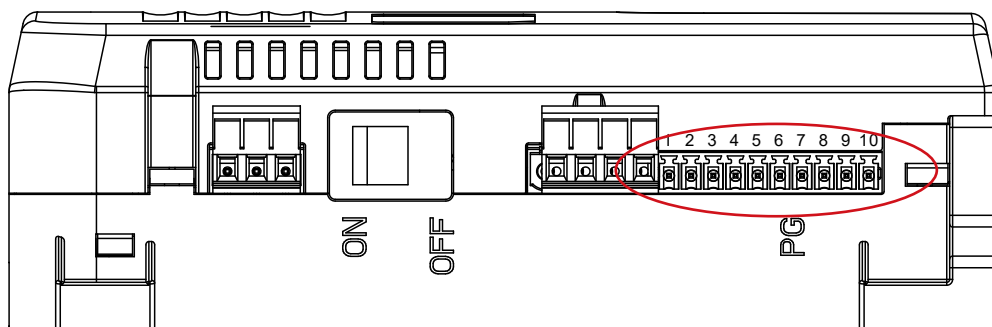

Pin No.	1	2	3	4	5	6	7	8	9	10
Function	PE	G	B	A	Z	\bar{Z}	+T*	-T*	5V	12V

* +T, -T would be connected to pin NTC+, NTC- on the ECMD motor, keep it empty if the chosen motor does not support NTC function (motor overheat protection).

※ For using 24V output, please refer to the VFD-DD user manual.

• **VFD - DD & ECMD**

Pin definitions and connection for the encoder feedback signal of motor

DD Pin No.	ECMD Pin Function	Color of Core Wire
PE	--	--
G	GND	BLU
B	B+	WHT
A	A+	BLK
Z	PWM+*	ORG
Z̄	PWM-*	ORG/RED
+T	A-/NTC+**	BLK/RED
-T	B-/NTC- **	WHT/RED
5V	+5VDC	BRN
12V	--	--

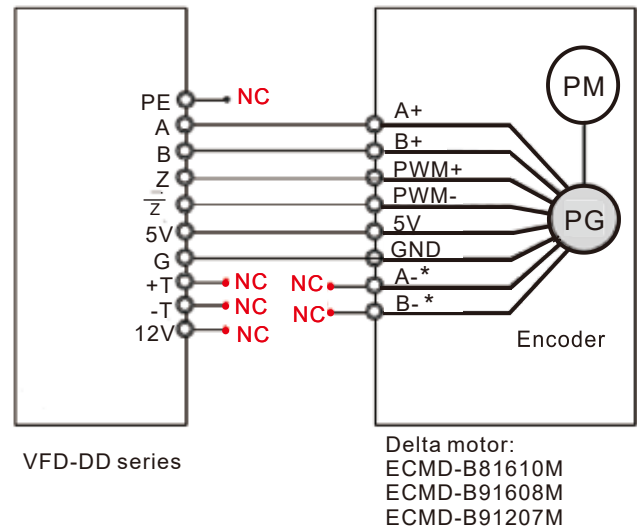

* PWM (Pulse Width Modulation): absolute encoder signal
 ** NTC function is under development.
 ※ For using 24V output, please refer to the VFD-DD user manual.

• **ECMD Motor**

Pin Definitions and Signal Cable Specifications (Without D-SUB connector)

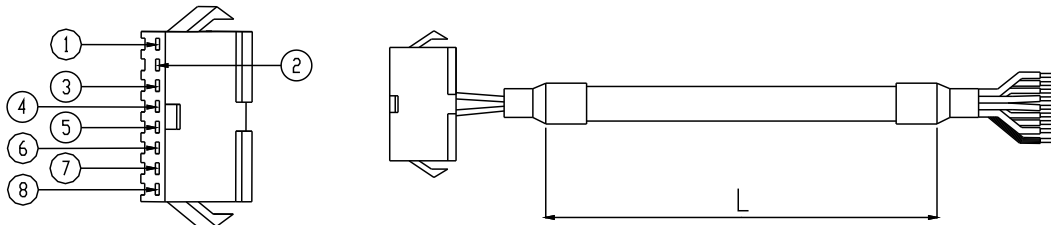

JOWL EC2522H02 -8P DETAIL		
Pin No.	Description	Color
1	A+	BLK
2	A-/NTC+**	BLK/RED
3	B+	WHT
4	B-/NTC- **	WHT/RED
5	PWM+*	ORG
6	PWM-*	ORG/RED
7	+5V	BRN
8	GND	BLUE

Model Name	L (mm)
MEC - SG0426S	385
MEC - SG1026S	1,000
MEC - SG2026S	2,000
MEC - SG3026S	3,000

* PWM (Pulse Width Modulation): absolute encoder signal
 ** NTC function is under development.

Model Name of ECMD Motor

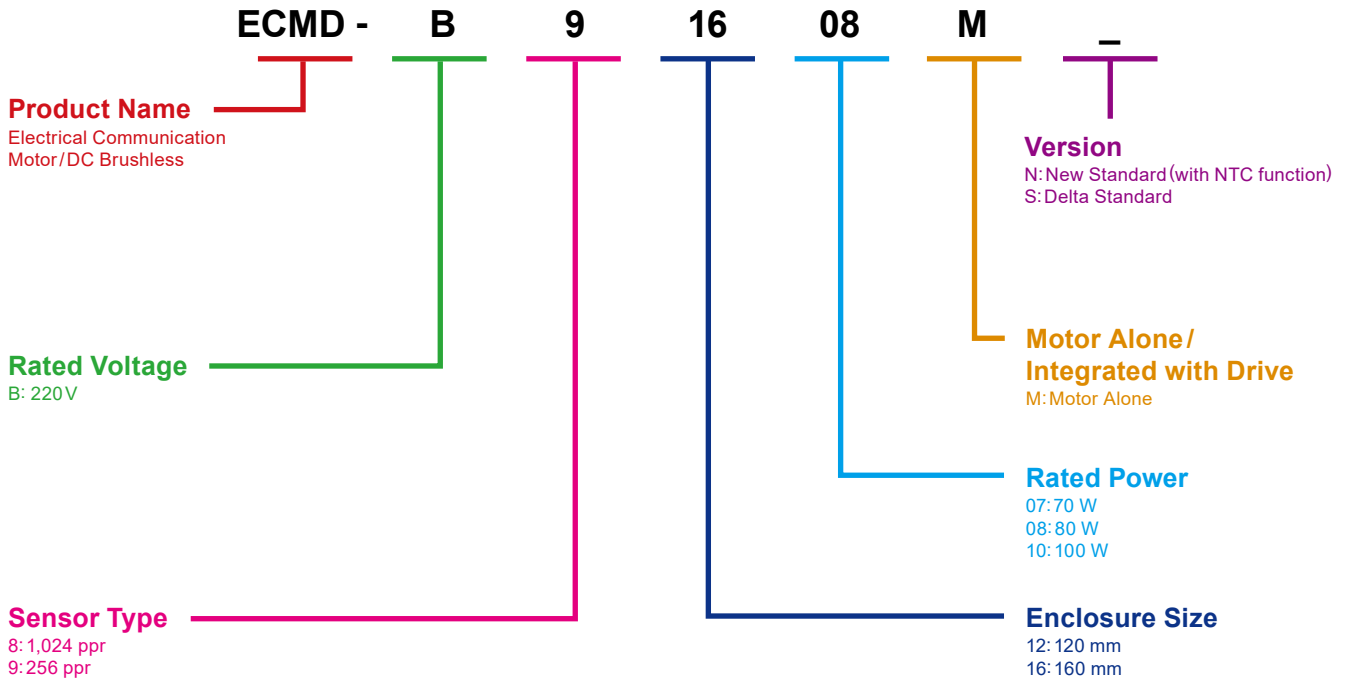

Model Name of Motor Cable

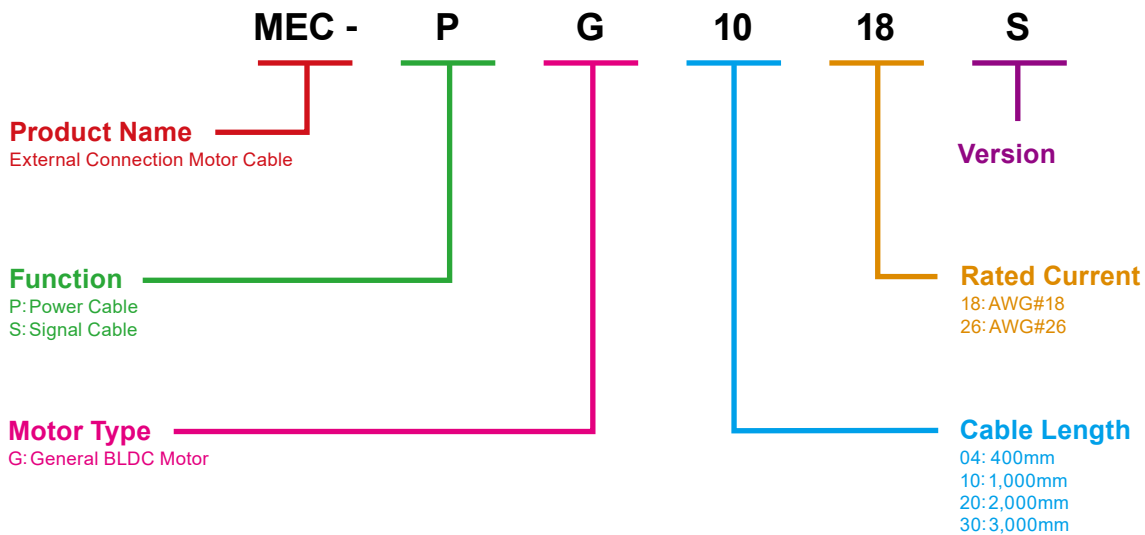

Ordering Information

VFD - DDSeries	Description
VFD001DD11S	115 V _{AC} - 1 Phase 100 W AC motor drive, supports IM&PM motors, built-in EMI filter
VFD002DD21S	230 V _{AC} - 1 Phase 200 W AC motor drive, supports IM&PM motors, built-in EMI filter
VFD004DD21S	230 V _{AC} - 1 Phase 400 W AC motor drive, supports IM&PM motors, built-in EMI filter
VFD002DD21V	230 V _{AC} - 1 Phase 200 W AC motor drive, supports IM&PM motors
VFD004DD21V	230 V _{AC} - 1 Phase 400 W AC motor drive, supports IM&PM motors
VFD002DD21T	230 V _{AC} - 1 Phase 200 W AC motor drive, supports IM&PM motors, built-in EMI filter/CAN*
VFD004DD21T	230 V _{AC} - 1 Phase 400 W AC motor drive, supports IM&PM motors, built-in EMI filter/CAN*
VFD002DD21F	230 V _{AC} - 1 Phase 200 W motor drive, Supports IM&PM motors, built-in EMI Filter, slim type

*CANopen protocol is provided upon request, please contact Industrial Automation Business Group

VFD - DDSeries	Description
ECMD - B91207MN	Servo motor enclosure size 120 mm, rated power 70 W, torque 2.0 N-m, speed 350 rpm (different bearing key)
ECMD - B91207MS	Servo motor enclosure size 120 mm, rated power 70 W, torque 2.0 N-m, speed 350 rpm
ECMD - B91608MS	Servo motor enclosure size 160 mm, rated power 80 W, torque 3.0 N-m, speed 250 rpm
ECMD - B81610MS	Servo motor enclosure size 160 mm, rated power 100 W, torque 3.5 N-m, speed 280 rpm

*Without power cable and encoder cable

VFD - DDSeries	Description
MEC - SG0426S	385 mm ECMD motor encoder cable, without D - SUB connector
MEC - SG1026S	1,000 mm ECMD motor encoder cable, without D - SUB connector
MEC - SG2026S	2,000 mm ECMD motor encoder cable, without D - SUB connector
MEC - SG3026S	3,000 mm ECMD motor encoder cable, without D - SUB connector
MEC - PG0418S	370 mm ECMD motor power cable
MEC - PG1018S	1,000 mm ECMD motor power cable
MEC - PG2018S	2,000 mm ECMD motor power cable
MEC - PG3018S	3,000 mm ECMD motor power cable
DPB - N7860	ECMD - B91207MS dust cap
DPB - N7779	ECMD - B91608M_ / ECMD - B81610M_ dust cap



Smarter. Greener. Together.

Industrial Automation Headquarters

Taiwan: Delta Electronics, Inc.

Taoyuan Technology Center
No.18, Xinglong Rd., Taoyuan District,
Taoyuan City 33068, Taiwan
TEL: +886-3-362-6301 / FAX: +886-3-371-6301

Asia

China: Delta Electronics (Shanghai) Co., Ltd.

No.182 Minyu Rd., Pudong Shanghai, P.R.C.
Post code : 201209
TEL: +86-21-6872-3988 / FAX: +86-21-6872-3996
Customer Service: 400-820-9595

Japan: Delta Electronics (Japan), Inc.

Industrial Automation Sales Department
2-1-14 Shibadaimon, Minato-ku
Tokyo, Japan 105-0012
TEL: +81-3-5733-1155 / FAX: +81-3-5733-1255

Korea: Delta Electronics (Korea), Inc.

1511, 219, Gasan Digital 1-Ro., Geumcheon-gu,
Seoul, 08501 South Korea
TEL: +82-2-515-5305 / FAX: +82-2-515-5302

Singapore: Delta Energy Systems (Singapore) Pte Ltd.

4 Kaki Bukit Avenue 1, #05-04, Singapore 417939
TEL: +65-6747-5155 / FAX: +65-6744-9228

India: Delta Electronics (India) Pvt. Ltd.

Plot No.43, Sector 35, HSIIDC Gurgaon,
PIN 122001, Haryana, India
TEL: +91-124-4874900 / FAX: +91-124-4874945

Thailand: Delta Electronics (Thailand) PCL.

909 Soi 9, Moo 4, Bangpoo Industrial Estate (E.P.Z),
Pattana 1 Rd., T.Phraksa, A.Muang,
Samutprakarn 10280, Thailand
TEL: +66-2709-2800 / FAX: +66-2709-2827

Australia: Delta Electronics (Australia) Pty Ltd.

Unit 20-21/45 Normanby Rd., Notting Hill Vic 3168, Australia
TEL: +61-3-9543-3720

Americas

USA: Delta Electronics (Americas) Ltd.

5101 Davis Drive, Research Triangle Park, NC 27709, U.S.A.
TEL: +1-919-767-3813 / FAX: +1-919-767-3969

Brazil: Delta Electronics Brazil

Rua Itapeva, 26 - 3º, andar Edifício Itapeva,
One - Bela Vista 01332-000 - São Paulo - SP - Brazil
TEL: +55-12-3932-2300 / FAX: +55-12-3932-237

Mexico: Delta Electronics International Mexico S.A. de C.V.

Gustavo Baz No. 309 Edificio E PB 103
Colonia La Loma, CP 54060
Tlalnepantla, Estado de México
TEL: +52-55-3603-9200

EMEA

EMEA Headquarters: Delta Electronics (Netherlands) B.V.

Sales: Sales.IA.EMEA@deltaww.com
Marketing: Marketing.IA.EMEA@deltaww.com
Technical Support: iatechnicalsupport@deltaww.com
Customer Support: Customer-Support@deltaww.com
Service: Service.IA.emea@deltaww.com
TEL: +31(0)40 800 3900

BENELUX: Delta Electronics (Netherlands) B.V.

Automotive Campus 260, 5708 JZ Helmond, The Netherlands
Mail: Sales.IA.Benelux@deltaww.com
TEL: +31(0)40 800 3900

DACH: Delta Electronics (Netherlands) B.V.

Coesterweg 45, D-59494 Soest, Germany
Mail: Sales.IA.DACH@deltaww.com
TEL: +49(0)2921 987 0

France: Delta Electronics (France) S.A.

ZI du bois Challand 2, 15 rue des Pyrénées,
Lisses, 91090 Evry Cedex, France
Mail: Sales.IA.FR@deltaww.com
TEL: +33(0)1 69 77 82 60

Iberia: Delta Electronics Solutions (Spain) S.L.U

Ctra. De Villaverde a Vallecas, 265 1º Dcha Ed.
Hormigueras – P.I. de Vallecas 28031 Madrid
TEL: +34(0)91 223 74 20

Carrer Llacuna 166, 08018 Barcelona, Spain

Mail: Sales.IA.Iberia@deltaww.com

Italy: Delta Electronics (Italy) S.r.l.

Via Meda 2-22060 Novedrate(CO)
Piazza Grazioli 18 00186 Roma Italy
Mail: Sales.IA.Italy@deltaww.com
TEL: +39 039 8900365

Russia: Delta Energy System LLC

Vereyskaya Plaza II, office 112 Vereyskaya str.
17 121357 Moscow Russia
Mail: Sales.IA.RU@deltaww.com
TEL: +7 495 644 3240

Turkey: Delta Greentech Elektronik San. Ltd. Sti. (Turkey)

Şerifali Mah. Hendem Cad. Kule Sok. No:16-A
34775 Ümraniye – İstanbul
Mail: Sales.IA.Turkey@deltaww.com
TEL: + 90 216 499 9910

MEA: Eltek Dubai (Eltek MEA DMCC)

OFFICE 2504, 25th Floor, Saba Tower 1,
Jumeirah Lakes Towers, Dubai, UAE
Mail: Sales.IA.MEA@deltaww.com
TEL: +971(0)4 2690148