



Industrial Automation Headquarters

Delta Electronics, Inc.
Taoyuan Technology Center
No.18, Xinglong Rd., Taoyuan District,
Taoyuan City 33068, Taiwan
TEL: 886-3-362-6301 / FAX: 886-3-371-6301

Asia

Delta Electronics (Shanghai) Co., Ltd.
No.182 Minyu Rd., Pudong Shanghai, P.R.C.
Post code : 201209
TEL: 86-21-6872-3988 / FAX: 86-21-6872-3996
Customer Service: 400-820-9595

Delta Electronics (Japan), Inc.

Tokyo Office
Industrial Automation Sales Department
2-1-14 Shibadaimon, Minato-ku
Tokyo, Japan 105-0012
TEL: 81-3-5733-1155 / FAX: 81-3-5733-1255

Delta Electronics (Korea), Inc.

Seoul Office
1511, 219, Gasan Digital 1-Ro., Geumcheon-gu,
Seoul, 08501 South Korea
TEL: 82-2-515-5305 / FAX: 82-2-515-5302

Delta Energy Systems (Singapore) Pte Ltd.

4 Kaki Bukit Avenue 1, #05-04, Singapore 417939
TEL: 65-6747-5155 / FAX: 65-6744-9228

Delta Electronics (India) Pvt. Ltd.

Plot No.43, Sector 35, HSIDC Gurgaon,
PIN 122001, Haryana, India
TEL: 91-124-4874900 / FAX : 91-124-4874945

Delta Electronics (Thailand) PCL.

909 Soi 9, Moo 4, Bangpoo Industrial Estate (E.P.Z),
Pattana 1 Rd., T.Phraksa, A.Muang,
Samutprakarn 10280, Thailand
TEL: 66-2709-2800 / FAX : 662-709-2827

Delta Electronics (Australia) Pty Ltd.

Unit 20-21/45 Normanby Rd., Notting Hill Vic 3168, Australia
TEL: 61-3-9543-3720

Americas

Delta Electronics (Americas) Ltd.

Raleigh Office
P.O. Box 12173, 5101 Davis Drive,
Research Triangle Park, NC 27709, U.S.A.
TEL: 1-919-767-3813 / FAX: 1-919-767-3969

Delta Electronics Brazil

São Paulo Sales Office
Rua Itapeva, 26 - 3º, andar Edifício Itapeva,
One - Bela Vista 01332-000 - São Paulo - SP - Brazil
TEL: 55-12-3932-2300 / FAX: 55-12-3932-237

Delta Electronics International Mexico S.A. de C.V.

Mexico Office
Gustavo Baz No. 309 Edificio E PB 103
Colonia La Loma, CP 54060
Tlalnepanitla, Estado de México
TEL: 52-55-3603-9200

EMEA

Headquarters: Delta Electronics (Netherlands) B.V.

Sales: Sales.IA.EMEA@deltaww.com
Marketing: Marketing.IA.EMEA@deltaww.com
Technical Support: iatechnicalsupport@deltaww.com
Customer Support: Customer-Support@deltaww.com
Service: Service.IA.emea@deltaww.com
TEL: +31(0)40 800 3900

BENELUX: Delta Electronics (Netherlands) B.V.

De Witbogt 20, 5652 AG Eindhoven, The Netherlands
Mail: Sales.IA.Benelux@deltaww.com
TEL: +31(0)40 800 3900

DACH: Delta Electronics (Netherlands) B.V.

Coesterweg 45, D-59494 Soest, Germany
Mail: Sales.IA.DACH@deltaww.com
TEL: +49(0)2921 987 0

France: Delta Electronics (France) S.A.

ZI du bois Challand 2, 15 rue des Pyrénées,
Lisses, 91090 Evry Cedex, France
Mail: Sales.IA.FR@deltaww.com
TEL: +33(0)1 69 77 82 60

Iberia: Delta Electronics Solutions (Spain) S.L.U

Ctra. De Villaverde a Vallecas, 265 1º Dcha Ed.
Hormigueras – P.I. de Vallecas 28031 Madrid
TEL: +34(0)91 223 74 20

Carrer Llacuna 166, 08018 Barcelona, Spain

Mail: Sales.IA.Iberia@deltaww.com

Italy: Delta Electronics (Italy) S.r.l.

Via Meda 2-22060 Novedrate(CO)
Piazza Grazioli 18 00186 Roma Italy
Mail: Sales.IA.Italy@deltaww.com
TEL: +39 039 8900365

Russia: Delta Energy System LLC

Vereyskaya Plaza II, office 112 Vereyskaya str
17 121357 Moscow Russia
Mail: Sales.IA.RU@deltaww.com
TEL: +7 495 644 3240

Turkey: Delta Greentech Elektronik San. Ltd. Sti. (Turkey)

Şerifali Mah. Hendem Cad. Kule Sok. No:16-A
34775 Ümraniye – İstanbul
Mail: Sales.IA.Turkey@deltaww.com
TEL: + 90 216 499 9910

GCC: Delta Energy Systems AG (Dubai BR)

P.O. Box 185668, Gate 7, 3rd Floor, Hamarain Centre
Dubai, United Arab Emirates
Mail: Sales.IA.MEA@deltaww.com
TEL: +971(0)4 2690148

Egypt + North Africa: Delta Electronics

Unit 318, 3rd Floor, Trivium Business Complex, North 90 street,
New Cairo, Cairo, Egypt
Mail: Sales.IA.MEA@deltaww.com

A High Performance with Diverse Communication Interfaces Servo Drive ASDA-A2R Series User Manual



A High Performance with Diverse Communication Interfaces Servo Drive ASDA-A2R Series User Manual

www.deltaww.com



*We reserve the right to change the information in this catalogue without prior notice.

DELTA_IA-ASD_ASDA-A2R_UM_EN_20200818

Preface

Thank you for purchasing ASDA-A2R. This user manual provides the related information of ASDA-A2R series servo drive and ECMA, ECML series servo motors. This manual includes:

- Installation and inspection of servo drive and servo motor
- The configuration of servo drive
- Procedures of trial run
- Control function and adjustment methods of servo drive
- Parameters
- Communication protocol
- Maintenance and inspections
- Troubleshooting

This manual addresses personnel with the following qualifications:

- Servo system designers
- Installation or wiring personnel
- Trial and tuning personnel
- Maintenance and inspection personnel

Before using the product, please read through this manual carefully in order to ensure the correct use of the product. In addition, please place this manual safely for quick reference whenever is needed. Please follow the rules below if you have not finished reading this manual yet.

- No water, corrosive gas and inflammable gas are allowed in installation environment.
- Three-phase power is prohibited to connect to U, V and W connector when wiring. It is possible to damage the servo drive.
- Ground is a must.
- Do not disassemble the servo drive, motor, or change the wiring when connecting to the power.
- Be ensured that the emergency stop can be activated anytime before connecting to the power and operation.
- Do not touch the heat sink to avoid scald when connecting to the power and operation.

If you have any enquiry, please contact the distributors or DELTA customer service center.

Safety Precautions

ASDA-A2R series is the high resolution and open type servo drive. It should be installed in a shielded control box during operation. This servo drive uses precise feedback control and the digital signal processor with high-speed calculation function to control the current output generated by IGBT so as to operate three-phase permanent magnet synchronous motors (PMSM) and to achieve precise positioning.

ASDA-A2R is applicable on industrial application and is suggested to be installed in the distribution board. (Servo drives, wire rod and motors all should be installed in the environment which complies with the minimum requirement of UL Level 1.)

Pay special attention to the following safety precautions anytime during inspection, installation, wiring, operation, maintenance, and examination.

The symbol of **danger**, **warning** and **stop** represent:



It indicates the potential hazards. It is possible to cause severe injury or fatal harm if not follow the instructions.



It indicates the potential hazards. It is possible to cause minor injury or lead to serious damage of the product or even malfunction if not follow the instructions.



It indicates the absolute prohibited activity. It is possible to damage the product or cannot be used due to malfunction if not follow the instructions.

Inspection



- Please follow the instruction when using servo drive and servo motor, or it is possible to cause fire or malfunction.

Installation



- It is prohibited to expose the product to the environment containing water, corrosive gas, inflammable gas, etc. Or it is possible to cause electric shock or fire.

Wiring



- Please connect the ground terminal to class-3 ground system (under 100 Ω), poor grounding may result in electric shock or fire.
- Do not connect the three-phase source to the motor output terminal U, V and W. Or it is possible to cause personnel injury or fire.
- Please tighten the screws of the power and motor output terminal. Or it is possible to cause fire.
- Please connect wiring according to the wire rod in order to prevent any danger.

Operation



- Before the operation, please change the parameter setting value according to the needs. If it is not adjusted to the correct setting value, it is possible to lead to malfunction of the machine or the operation might out of control.
- Before the machine starts to operate, please be ensured the emergency stop can be activated anytime.
- When power is on, please make sure the motor shaft stands still and will not operate because of mechanical inertia or other causes.



- During the operation, it is prohibited to touch any rotating motor parts. Or it is possible to cause personnel injury.



- In order to prevent any accident, please separate the couplings and belts of the machine and isolate them. Then conduct the initial trial run.
- If users fail to operate the machine properly after the servo motor connects to the equipments, it would cause the damage of the equipments and lead to the personnel injury.
- In order to prevent the danger, it is strongly recommended to check if the motor can operate normally without load first. Then, operate the motor with load.
- Do not touch the heat sink of the servo drive. Or it is possible to cause scald due to the high temperature.

Maintenance and Inspection



- It is prohibited to touch the internal parts of the servo drive and servo motor. Or it is possible to cause electric shock.
- It is prohibited to disassemble the panel of the servo drive when turning on the power. Or it is possible to cause electric shock.
- Do not touch the ground terminal within 10 minutes after turning off the power. Or the residual voltage may cause electric shock.
- Do not disassemble the motor. Or it is possible to cause electric shock or personnel injury.
- Do not change the wiring when the power is on. Or it is possible to cause electric shock or personnel injury.
- Only the qualified electrical and electronics professionals can install, wire and maintain the servo drive and servo motor.

Main Circuit Wiring



- Do not put the power cable and the encoder cable in the same channel and bond them together. Please separate the power cable and the encoder cable for at least 30 centimeters (= 11.8 inches) when wiring.
- Please use stranded wires and multi-core shielded-pair wires for the encoder cables and encoder PG feedback cables. The maximum length of command input cable is 3 meters (= 9.84 feet) and the maximum length of PG feedback cable is 20 meters (= 65.62 feet).
- The high voltage might remain in the servo motor even when the power is off. Do not touch the power terminal temporarily (at least 10 minutes). Please conduct the inspection not until the indicator light, **CHARGE** is off.



- Do not turn the power on and off too often. If continuous power on and off is needed, please be ensured the interval is one minute at most.

Terminal Wiring of the Main Circuit



- When wiring, please disassemble the terminal socket from the servo drive.
- One terminal of the terminal socket for one electric wire only.
- When inserting the electric wires, do not connect the conductor to the adjacent wire.
- Before connecting to the power, please inspect and be ensured the wiring is correct.

Note: if there is any difference of each version, please refer to DELTA's website (<https://www.deltaww.com/>) for the latest information.

Safety precautions when connecting to linear motor



- Do not touch servo motor when the power is on. Or it is possible to cause electric shock.
- Do not touch the ground terminal within 10 minutes after turning off the power. Or the residual voltage may cause electric shock.
- Do not change the wiring when the power is on. Or it is possible to cause electric shock or personnel injury.



- Do not touch the motor during operation. Or it is possible to cause scald due to the high temperature.
- Do not touch the machine that just turned off, the residual temperature might cause scald.



- Strong magnets! It can be harmful to pacemaker wearers and other with medical implants.



- Caution, strong magnet field.



- Mechanical hazard! To avoid jammed during maintenance.



- Improper installation is prohibited, such as to knock, to cut off, to stamp on or to tighten incorrect mechanism.

Note: if there is any difference of each version, please refer to DELTA's website (<https://www.deltaww.com/>) for the latest information.

(This page is intentionally left blank.)

Table of Contents

Chapter 1 Inspection and Model Explanation

1.1	Inspection	1-1
1.2	Product Model	1-3
1.2.1	Nameplate Information.....	1-3
1.2.2	Model Explanation.....	1-5
1.3	Servo Drive and Corresponding Servo Motor	1-9
1.4	Each Part of the Servo Drive.....	1-10
1.5	ECML Series Servo Motor.....	1-13

Chapter 2 Installation

2.1	Notes	2-1
2.2	Ambient Conditions of Storage	2-1
2.3	Ambient Conditions of Installation	2-2
2.4	Installation Direction and Space	2-3
2.5	Specification of Circuit Breaker and Fuse	2-4
2.6	EMI Filters Selection	2-5
2.7	Selection of Regenerative Resistor	2-7

Chapter 3 Wiring

3.1	Wiring of Delta's Servo System	3-1
3.1.1	Wiring Diagram of Peripheral Devices (connect to Delta's Servo Motor Communication Type)	3-1

3.1.2	Connectors and Terminals of the Servo Drive.....	3-3
3.1.3	Wiring Method.....	3-5
3.1.4	Specification of ECMA Motor U, V, W Power Cable	3-7
	Specification of ECML Motor U, V, W Power Cable	3-9
3.1.5	Specification of Connector of Encoder Cable.....	3-10
	Specification and Definition of Motor Signal Cable.....	3-13
3.1.6	Selection of Wire Rod.....	3-14
3.2	Schematic Diagram of Servo System.....	3-16
3.3	I/O Signal (CN1) Connection.....	3-18
3.3.1	I/O Signal (CN1) Connector Terminal Layout	3-18
3.3.2	Explanation of I/O (CN1) Connector Signal	3-20
3.3.3	Wiring Diagram (CN1).....	3-30
3.3.4	The DI and DO Signal Specified by the User	3-38
3.3.5	Application: Wiring of CN1 Quick Connector.....	3-39
3.4	CN2 Connector	3-42
3.5	Wiring of CN3 Connector	3-45
3.5.1	Layout of CN3 Connector	3-45
3.5.2	Connection between CN3 Connector and Personal Computer	3-46
3.6	CN4 Serial Connector (USB).....	3-47
3.7	CN5 Connector (Full-closed Loop)	3-48
3.8	CN6 Connector (CANopen)	3-49
3.9	Extension Digital Input Connector of CN7	3-51
3.10	Standard Wiring Method	3-52

- 3.10.1 Position (PT) Mode Standard Wiring 3-52
- 3.10.2 Position (PR) Mode Standard Wiring 3-53
- 3.10.3 Speed Mode Standard Wiring 3-54
- 3.10.4 Torque Mode Standard Wiring 3-55
- 3.10.5 CANopen Mode Standard Wiring 3-56
- 3.11 Wiring System of other Brand of Motor 3-57
 - 3.11.1 Wiring Diagram of Peripheral Devices 3-57
 - 3.11.2 Specification of Definition of ECML Motor Cable 3-61
 - 3.11.3 Signal Converter Box 3-63

Chapter 4 Panel Display and Operation

- 4.1 Panel Description 4-1
- 4.2 Parameter Setting Procedure 4-2
- 4.3 Status Display 4-5
 - 4.3.1 Setting Saved Display 4-5
 - 4.3.2 Decimal Point 4-5
 - 4.3.3 Alarm Message 4-5
 - 4.3.4 Positive and Negative Sign Setting 4-5
 - 4.3.5 Monitor Display 4-6
- 4.4 General Function 4-9
 - 4.4.1 Operation of Fault Record Display 4-9
 - 4.4.2 JOG Mode 4-10
 - 4.4.3 Force DO Output 4-11

4.4.4	Digital Input Diagnosis Operation	4-12
4.4.5	Digital Output Diagnosis Operation	4-12

Chapter 5 Trial Operation and Tuning

5.1	Inspection without Load	5-1
5.2	Apply Power to the Servo Drive	5-2
5.3	JOG Trial Run without Load	5-5
5.4	Trial Run without Load (Speed Mode)	5-6
5.5	Trial Run without Load (Position Mode)	5-9
5.6	Tuning Procedure	5-11
5.6.1	Flowchart of Tuning Procedure	5-12
5.6.2	Inertia Estimation Flowchart (with Mechanism)	5-13
5.6.3	Flowchart of Auto Tuning	5-14
5.6.4	Flowchart of Semi-auto Tuning	5-15
5.6.5	Limit of Inertia Ratio for Rotary Motor / Total Weight of Linear Motor and Load (kg)	5-16
5.6.6	Mechanical Resonance Suppression Method	5-19
5.6.7	Tuning Mode and Parameters	5-20
5.6.8	Tuning in Manual Mode	5-21

Chapter 6 Control Mode and Operation

6.1	Selection of Operation Mode	6-1
6.2	Position Mode	6-3
6.2.1	Position Command in PT Mode	6-3

6.2.2	Position Command in PR Mode	6-3
6.2.3	Control Structure of Position Mode	6-4
6.2.4	S-Curve Filter (Position)	6-6
6.2.5	Electronic Gear Ratio.....	6-7
6.2.6	Low-pass Filter	6-8
6.2.7	Timing Diagram in Position Mode (PR).....	6-8
6.2.8	Gain Adjustment of Position Loop.....	6-9
6.2.9	Low-frequency Vibration Suppression in Position Mode	6-10
6.3	Speed Mode	6-13
6.3.1	Selection of Speed Command	6-13
6.3.2	Control Structure of Speed Mode	6-15
6.3.3	Smooth Speed Command.....	6-16
6.3.4	The Scaling of Analog Command	6-18
6.3.5	The Timing Diagram in Speed Mode.....	6-18
6.3.6	Gain Adjustment of Speed Loop.....	6-19
6.3.7	Resonance Suppression.....	6-24
6.4	Torque (force) Mode	6-29
6.4.1	Selection of Torque (force) Command.....	6-29
6.4.2	Control Structure of Torque (force) Mode.....	6-30
6.4.3	Smooth Torque (force) Command	6-31
6.4.4	The Scaling of Analog Command	6-31
6.4.5	The Timing Diagram in Torque (force) Mode	6-32
6.5	Dual Mode	6-33

6.5.1	Speed / Position Dual Mode	6-34
6.5.2	Speed / Torque (force) Dual Mode	6-34
6.5.3	Torque (force) / Position Dual Mode	6-35
6.6	Others	6-36
6.6.1	The Use of Speed Limit	6-36
6.6.2	The Use of Torque (force) Limit	6-36
6.6.3	Analog Monitor	6-37
6.6.4	The Use of Brake	6-38

Chapter 7 Motion Control

7.1	Motion Control Functions of ASDA-A2R	7-1
7.2	Information of the Servo Drive	7-1
7.2.1	Description of Monitor Variables	7-2
7.2.2	Description of Data Array	7-8
7.3	Description of Motion Axes	7-11
7.4	Description of PR Mode	7-12
7.5	The Difference between General PR Mode and the One in ASDA-A2R	7-13
7.6	The Position Unit of PR Mode	7-14
7.7	Description of Register in PR Mode	7-14
7.8	Homing Description of PR Mode	7-16
7.9	DI/DO Provided by PR Mode and Diagrams	7-16
7.10	Parameter Settings in PR Mode	7-18
7.10.1	The Relation between the Previous Path the and Next Path	7-25

7.10.2 Programming the Path in PR Mode 7-25

7.11 The Description of E-Cam Function..... 7-27

7.11.1 Function Description of CAPTURE (Data Capture)..... 7-36

7.11.2 Function Description of COMPARE (Data Compare) 7-38

Chapter 8 Parameters

8.1 Parameter Definition 8-1

8.2 List of Parameters..... 8-2

8.3 Parameter Description 8-18

P0-xx Monitor Parameters..... 8-18

P1-xx Basic Parameters 8-39

P2-xx Extension Parameters 8-84

P3-xx Communication Parameters..... 8-122

P4-xx Diagnosis Parameters 8-129

P5-xx Motion Setting Parameters 8-141

P6-xx PR Parameters 8-210

P7-xx PR Parameters 8-259

PM-xx Motor Parameters 8-273

Table 8.1 Function Description of Digital Input (DI) 8-298

Table 8.2 Function Description of Digital Output (DO)..... 8-305

Chapter 9 Communication

9.1 RS-485 Communication Hardware Interface 9-1

9.2 RS-485 Communication Parameters Setting 9-2

9.3	MODBUS Communication Protocol.....	9-3
9.4	Write-in and Read-out Communication Parameters.....	9-14

Chapter 10 Troubleshooting

10.1	Alarm of Servo Drive.....	10-1
10.2	Alarm of CANopen Communication.....	10-4
10.3	Alarm of Motion Control.....	10-6
10.4	Causes and Corrective Actions.....	10-10
10.5	Corrective Actions after the Alarm Occurs.....	10-32

Chapter 11 Specifications

11.1	Specifications of Servo Drive.....	11-1
11.2	Specifications of Servo Motor (ECMA Series).....	11-4
11.3	Specifications of Servo Motor (ECML Series).....	11-12
11.4	Torque Features (T-N curve).....	11-14
11.5	Force and Speed Features (F-S curve).....	11-16
11.6	Overload Features.....	11-18
11.7	Dimensions of the Servo Drive.....	11-20
11.8	Dimensions of ECMA Series Servo Motor.....	11-23
11.9	Dimensions of ECML Series Servo Motor.....	11-28

Chapter 12 Setting of Motor Parameters

12.1	Tuning Procedure of Motor Parameters.....	12-1
12.2	Panel Setup Procedure (without PC Software).....	12-23

Appendix A Accessories

Appendix B Maintenance and Inspection

(This page is intentionally left blank.)

Chapter 1 Inspection and Model Explanation

1.1 Inspection

In order to prevent the negligence during purchasing and delivery, please inspect the following items carefully.

- Please check if the product is what you have purchased: check the part number of the motor and the servo drive on the nameplate. Refer to the next page for the model explanation.
- Check if the motor shaft can rotate smoothly: Rotate the motor shaft by hand. If it can be rotated smoothly, it means the motor shaft is normal. However, it cannot be rotated by hand if the motor has an electromagnetic brake.
- Check if there is any damage shown on its appearance: visually check if there is any damage or scrape of the appearance.
- Check if there is any loose screw: If the screws are un-tightened or fall off.

If any of the above situations happens, please contact the distributors to solve the problems.

A complete and workable servo set should include:

- (1) A Servo drive and a servo motor
- (2) A UVW motor power cable, the U, V and W wires can connect to the socket attached by the servo drive and another side is the plug which could connect to the socket of the motor. And a green ground wire which should be locked to the ground terminal of the servo drive. (selective purchase)
- (3) An encoder cable which connects to the socket of the encoder. One side of it connects to CN2 servo drive and another side is the plug. (selective purchase)
- (4) Converter box. (selective purchase)
- (5) 26-PIN connector for CN26 of converter box (selective purchase)
- (6) 50-PIN connector which is used in CN1 (3M analog product) (selective purchase)
- (7) 20-PIN connector which is used in CN2 (3M analog product) (selective purchase)
- (8) 6-PIN connector which is used in CN3 (IEEE 1394 analog product) and is for general communication (RS485) (selective purchase)
- (9) 4-PIN connector which used in CN4 (USB Type B product) (selective purchase)
- (10) RJ45 connector which used in CN6 and is for high-speed communication (selective purchase)
- (11) 7-PIN connector which used in CN7, for extension DI. (-U model) (selective purchase)
- (12) Servo drive power input:

	Control circuit power	Main circuit power
100 W ~ 3 kW	L1c, L2C, ⊖ fast connector	R, S, T fast connector

- (13) 3-PIN fast connector (U, V, W)
- (14) 3-PIN fast connector (P[⊕], D, C)
- (15) A plastic lever
- (16) A metal short-circuit chip
- (17) An instruction sheet

1.2 Product Model

1.2.1 Nameplate Information

ASDA-A2R Series Servo Drive

■ Nameplate Information

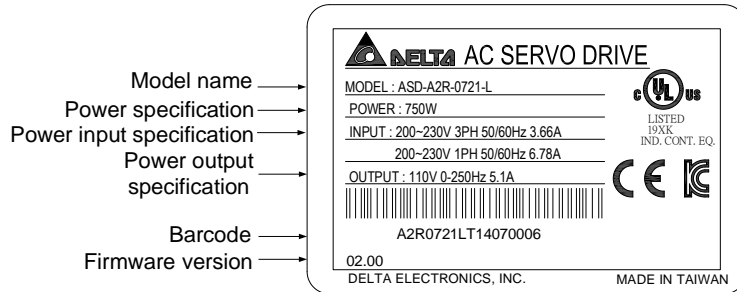

■ Serial Number

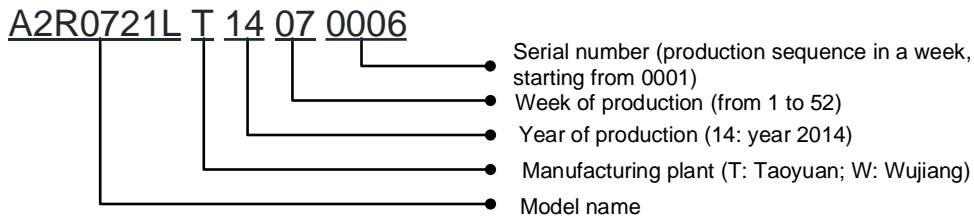

ECMA Series Servo Motor

■ Nameplate Information

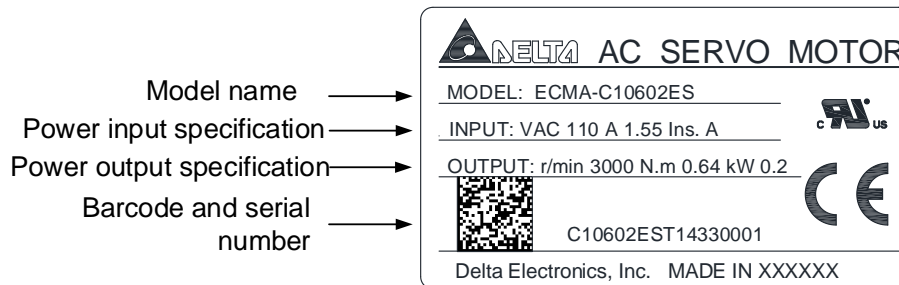

■ Serial Number

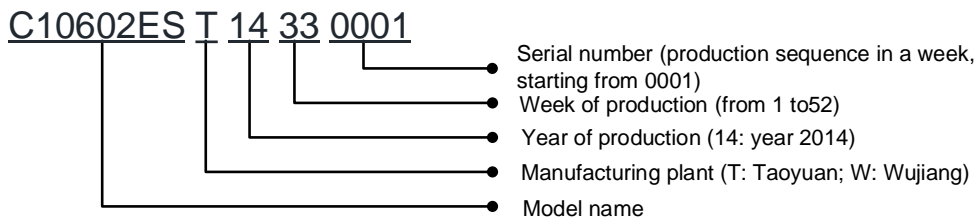

ECML Series Servo Motor

■ Coil Assembly_Nameplate Information



Linear Servo Motor

Model Name → MODEL: ECML-S3208A2DNS

Power Input Specification → INPUT: 200V 2.8A



Delta Electronics, Inc.
Made in Taiwan

S32082DST1500001

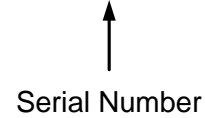

■ Coil assembly_Serial Number

S32082DS T 1 50 0001

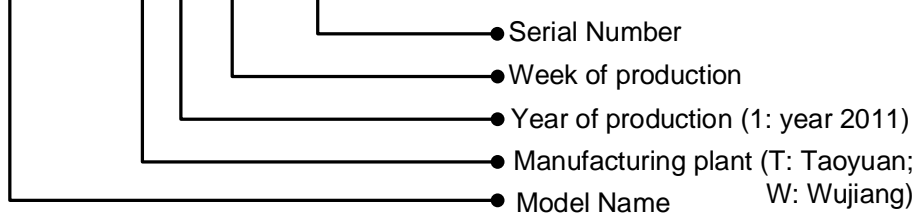

■ Magnetic way_Nameplate Information

Delta Electronics, Inc. ECML-SM322310S M322310ST1500001



■ Magnetic way_Serial Number

M322310S T 1 50 0001

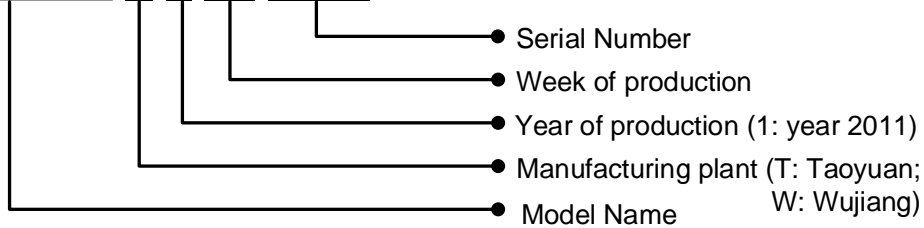

1.2.2 Model Explanation

ASDA-A2R Series Servo Drive

A S D - A 2 R - 0 1 2 1 - U

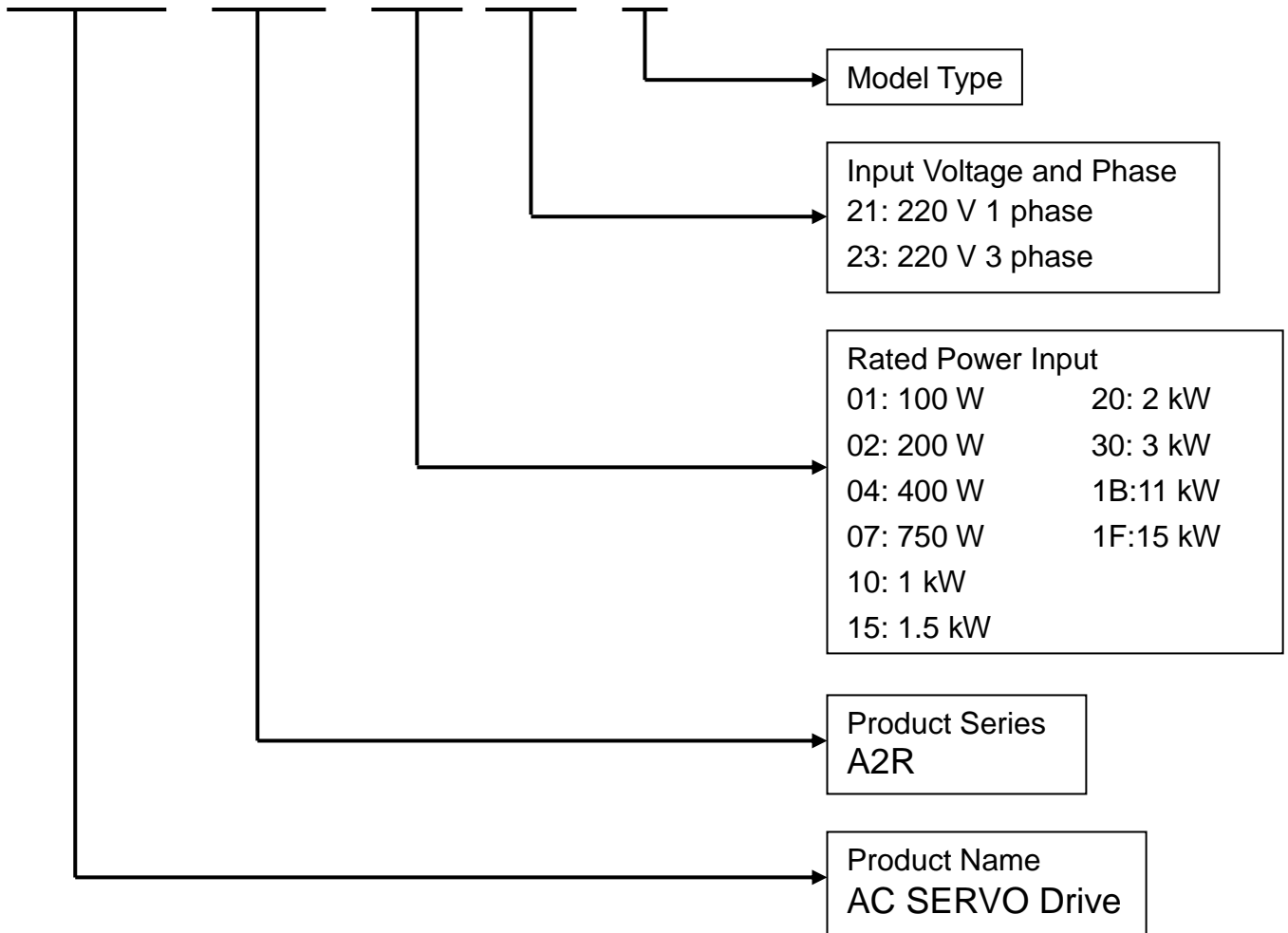

Model Type

Type	Full-closed Loop	CANopen	DMCNET	E-CAM	Expansion Slot for Digital Input
M	○	○	×	○	×
U	○	×	×	○	○
F	○	×	○	×	×
L	○	×	×	×	×

ECMA Series Servo Motor

E C M A - C 1 0 6 0 2 E S

Standard Shaft Diameter: S
 Specific Shaft Diameter: 3=42mm,
 7=14mm

Type of Shaft Diameter and Oil Seal	w/o Brake w/o Oil Seal	with Brake w/o Oil Seal	w/o Brake with Oil Seal	With Brake With Oil Seal
Round Shaft (with fixed screw holes)	A	B	C	D
Keyway	E	F	G	H
Keyway (with fixed screw holes)	P	Q	R	S

Rated Power Output

0F:50 W	09:900 W
01:100 W	10:1.0 kW
02:200 W	13:1.3 kW
03:300 W	15:1.5 kW
04:400 W	18:1.8 kW
05:500 W	20:2.0 kW
06:600 W	30:3.0 kW
07:700 W	35:3.5 kW
08:850 W	

Motor Frame Size

04:40 mm	09:86 mm	18:180 mm
06:60 mm	10:100 mm	22:220 mm
08:80 mm	13:130 mm	

Name of the Series
 Rated Voltage and Rated Speed

C = 220 V/3,000 rpm;
E = 220 V/2,000 rpm;
F = 220 V/1,500 rpm;
G = 220 V/1,000 rpm;

Encoder Type

1: Incremental, 20-bit
 2: Incremental, 17-bit

Servo Type
 A: AC Servo

Product Name
 ECM: Electronic Commutation Motor

ECML Series Servo Motor_Magnetic Way

ECM L - S M 16 1000 S

Total length of magnetic way
0340: 340 mm
0520: 520 mm
0700: 700 mm
0880: 880 mm
1060: 1060 mm
1240: 1240 mm

Magnetic way dimensions
16: Ø16 mm
20: Ø20 mm
25: Ø25 mm
32: Ø32 mm

Component type
Null: coil assembly
M: magnetic way

Name of the Series
Linear motor type
S = Shaft type coreless

Servo Type
L: Linear servo drive

Product Name
ECM: Electronic Commutation Motor

ECML Series Servo Motor_Coil assembly

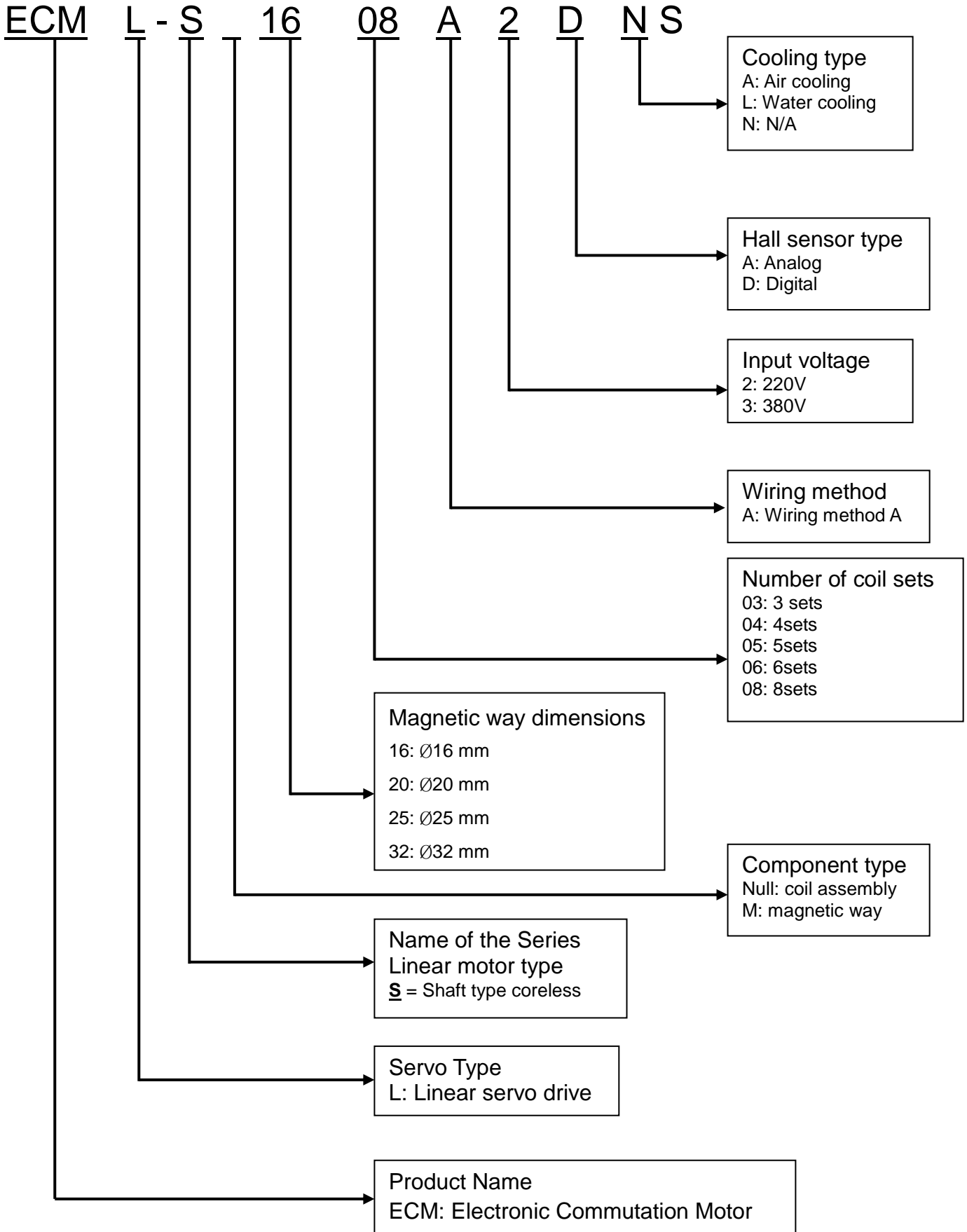

1.3 Servo Drive and Corresponding Servo Motor

	Servo Drive	Permanent magnet synchronous rotary motor (ECMA-)	Permanent magnet synchronous linear motor (ECML-)
100 W	ASD-A2R-0121-□	ECMA-C△0401□S (S = 8 mm) ECMA-C1040F□S (S = 8 mm)	ECML-S1606A2DNS ECML-S1608A2DNS
200 W	ASD-A2R-0221-□	ECMA-C△0602□S (S = 14 mm)	ECML-S2003A2DNS ECML-S2004A2DNS ECML-S2005A2DNS
400 W	ASD-A2R-0421-□	ECMA-C△0604□S (S = 14mm) ECMA-C△0804□7 (7 = 14 mm) ECMA-E△1305□S (S = 22 mm) ECMA-G△1303□S (S = 22 mm)	ECML-S2504A2DNS ECML-S2506A2DNS ECML-S3204A2DNS
750 W	ASD-A2R-0721-□	ECMA-F11305□S (S = 22 mm) ECMA-C△0807□S (S = 19 mm) ECMA-C△0907□S (S = 16 mm) ECMA-G△1306□S (S = 22 mm)	ECML-S2508A2DNS ECML-S3206A2DNS ECML-S3208A2DNS
1000 W	ASD-A2R-1021-□	ECMA-C△0910□S (S = 16 mm) ECMA-C△1010□S (S = 22 mm) ECMA-E△1310□S (S = 22 mm) ECMA-F△1308□S (S = 22 mm) ECMA-G△1309□S (S = 22 mm)	-
1500 W	ASD-A2R-1521-□	ECMA-E△1315□S (S = 22 mm)	-
2000 W	ASD-A2R-2023-□	ECMA-C△1020□S (S = 22 mm) ECMA-E△1320□S (S = 22 mm) ECMA-E△1820□S (S = 35 mm) ECMA-F11313□S (S = 22 mm) ECMA-F11318□S (S = 22 mm)	-
3000 W	ASD-A2R-3023-□	ECMA-C△1330□4 (4 = 24 mm) ECMA-E△1830□S (S = 35 mm) ECMA-E△1835□S (S = 35 mm) ECMA-F△1830□S (S = 35 mm)	-
11 kW	ASD-A2R-1B43-□	ECMA-L1221B□3 (3 = 42 mm)	
15 kW	ASD-A2R-1F43-□	ECMA-L1221F□S (S = 55 mm)	

Note:

- 1) Box, (□) at the end of the model name of the servo drive represents the code of ASDA-A2R. Please refer to the type of purchasing product information.
- 2) Box, (△) in the model name of the servo motor represents the type of encoder. △=1: incremental, 20-bit; △=2: incremental, 17-bit; △=A: absolute.
- 3) Box, (□) in the model name of the servo motor represents the type of brake or keyway / oil seal.

The above table shows the specification of servo drive which has triple rated current. If the user needs the servo drive which has six times of the rated current, please contact with distributors. For detailed specification of the servo motor and servo drive, please refer to the appendix.

1.4 Each Part of the Servo Drive

Front view of the servo drive

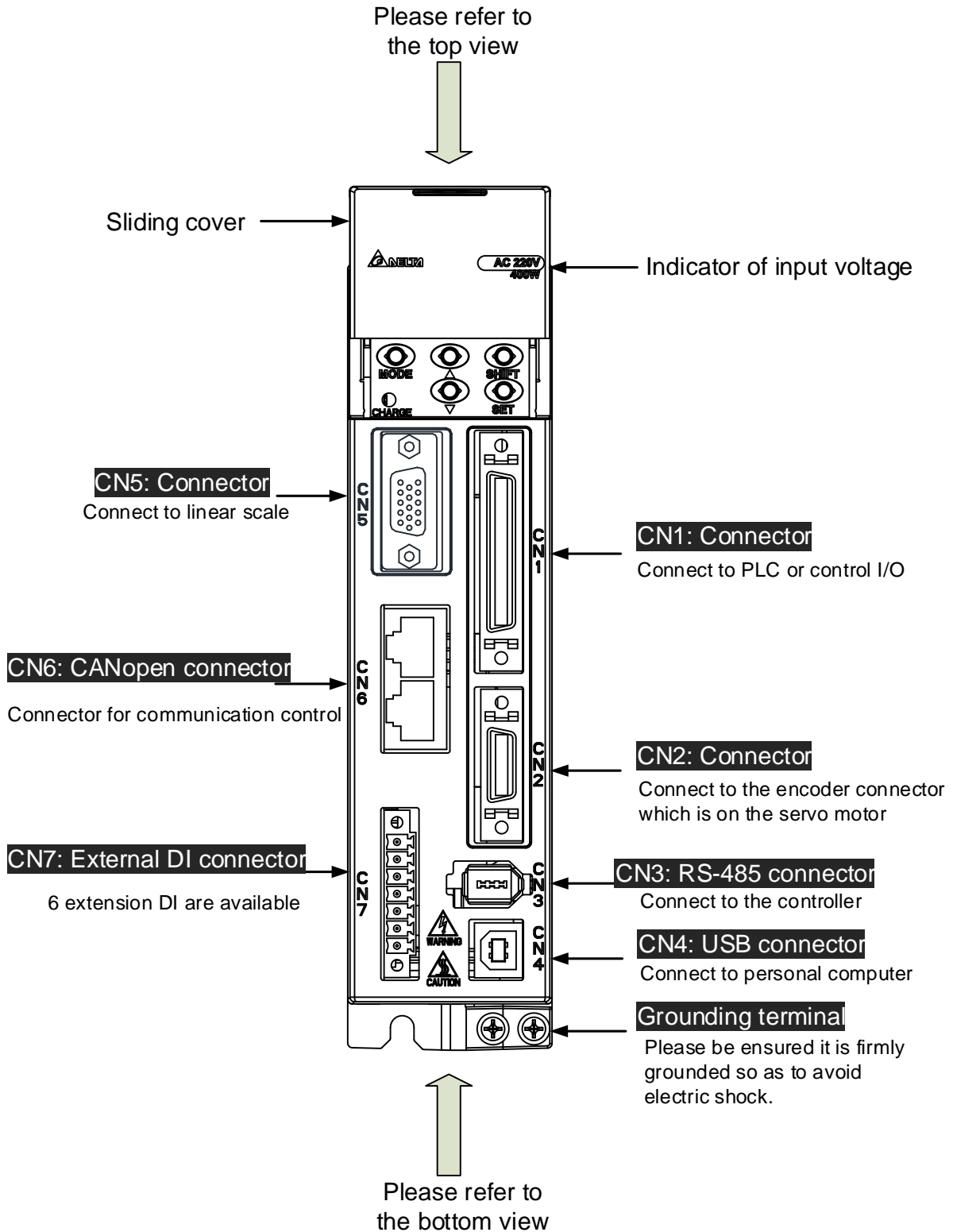

Top view of the servo drive

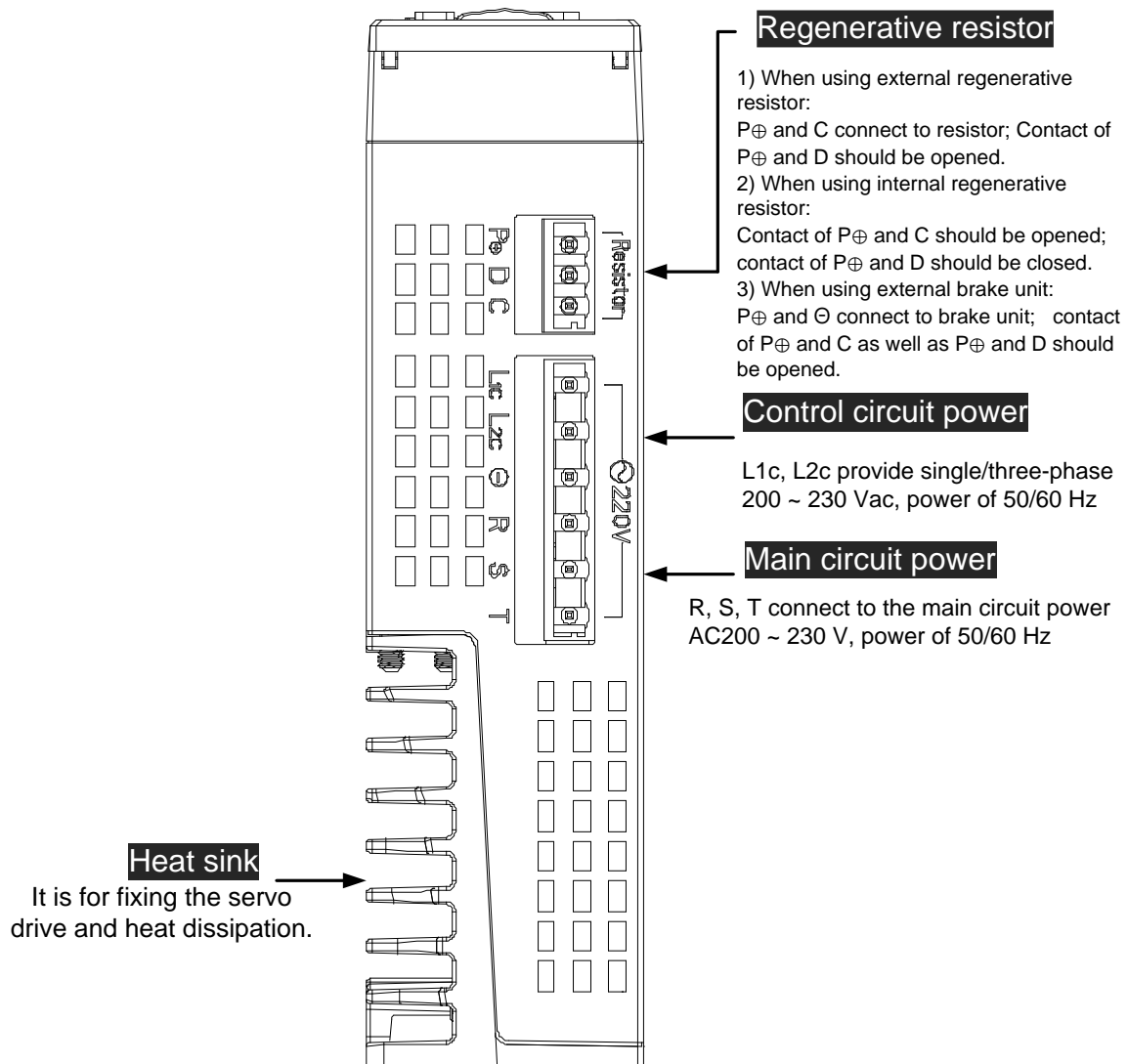

Bottom view of the servo drive

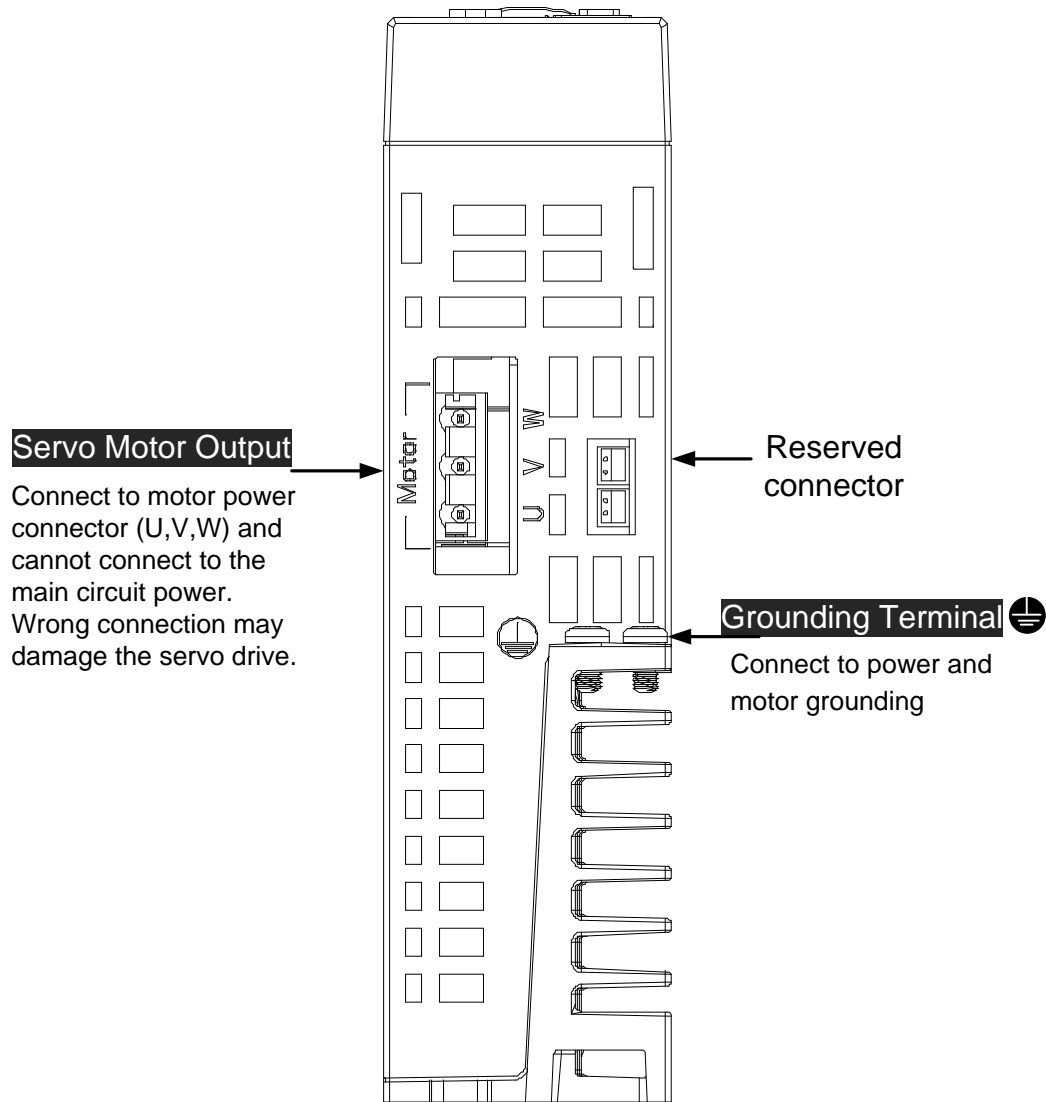

1.5 ECML Series Servo Motor

Encoder cable

It contains 7 core cables, which are for Hall Sensor and NTC thermistor. It connects to CN2 or CN5. Please refer to Ch3.1 for wiring method.

Motor power cable

It contains 4 core cables, which are for U, V, W and ground wire. It connects to output port of the servo drive and grounding terminal.

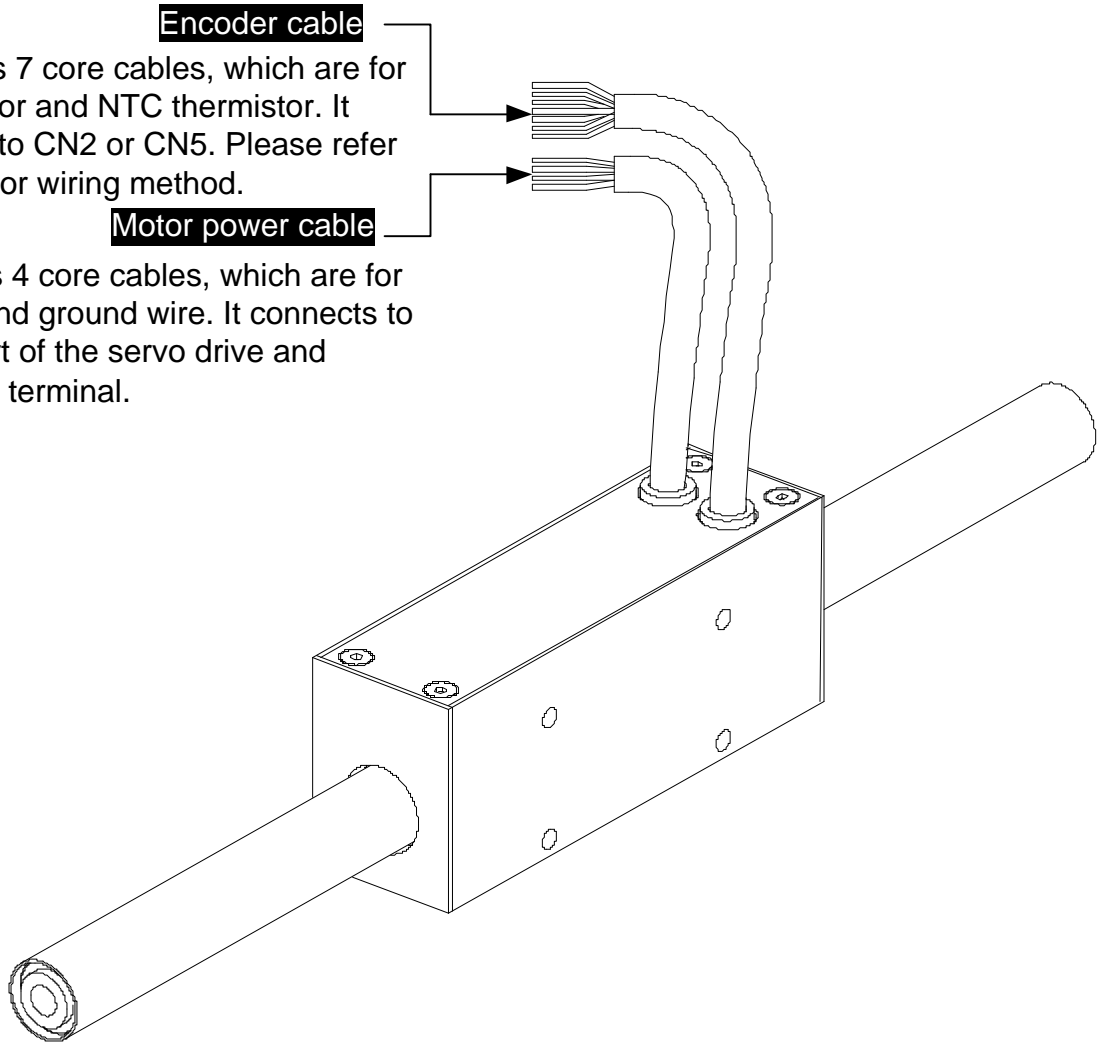

(This page is intentionally left blank.)

Chapter 2 Installation

2.1 Notes

Please pay special attention to the followings:

- 1) Do not strain the cable connection between the servo drive and the servo motor.
- 2) Make sure each screw is tightened when fixing the servo drive.
- 3) The motor shaft and the ball screw should be parallel.
- 4) If the connection between the servo drive and the servo motor is over 20 meters, please thicken the connecting wire, UVW as well as the encoder cable.
- 5) Tighten the fixed four screws of the motor.

2.2 Ambient Conditions of Storage

Before the installation, this product has to be kept in shipping carton. In order to retain the warranty coverage and for the maintenance, please follow the instructions below when storage, if the product is not in use temporarily:

- Store the product in a dry and dust-free location.
- Store the product within an ambient temperature range of -20 °C to +65 °C.
- Store the product within a relative humidity range of 0% to 90% and a non-condensing environment.
- Avoid storing the product in the environment of corrosive gas and liquid.
- It is better to store the product in shipping carton and put it on the shelf or working platform.

2.3 Ambient Conditions of Installation

The best temperature of this servo drive is between 0 °C and 55 °C. If the temperature is over 45 °C, please place the product in a well-ventilated environment so as to ensure its reliability performance. If the product is installed in an electric box, make sure the size of the electric box and its ventilation condition will not overheat and endanger the internal electronic device. Also, pay attention to the vibration of the machine. Check if the vibration will influence the electronic device of the electric box. Besides, the ambient conditions should also include:

- Location has no over-heat device.
- Location has no water drop, vapor, dust and oily dust.
- Location has no corrosive and inflammable gas and liquid.
- Location has no airborne dust and metal particles.
- Location has solid foundation and no vibration.
- Location has no interference of electromagnetic noise.

The ambient temperature of the motor is between 0°C and 40°C and the ambient conditions include:

- Location has no over-heat device.
- Location has not water drop, vapor, dust and oily dust.
- Location has no corrosive and inflammable gas and liquid.
- Location has no airborne dust and metal particles.

2.4 Installation Direction and Space

Notes:

Follow the instructions for installation direction. Otherwise it is possible to cause malfunction. In order to have well-cooling and circulation effect, the enough space between adjacent objects and the baffle is needed. Or it might result in malfunction. When installing AC servo drive, do not seal the suction hole and the vent hole. Do not place the drive in a horizontal direction, or it might cause malfunction.

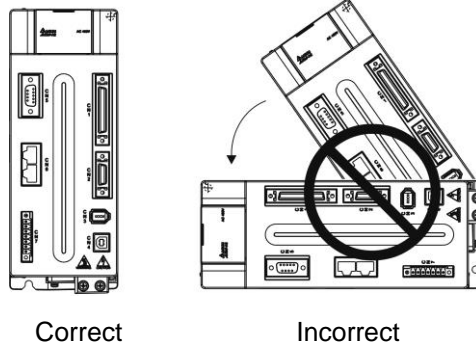

Correct

Incorrect

Scheme of installation:

In order to have smaller wind resistance of the fan and increase the ventilation, please follow the suggested clearance value when installing one or more than one servo drives. (Refer to the following diagrams)

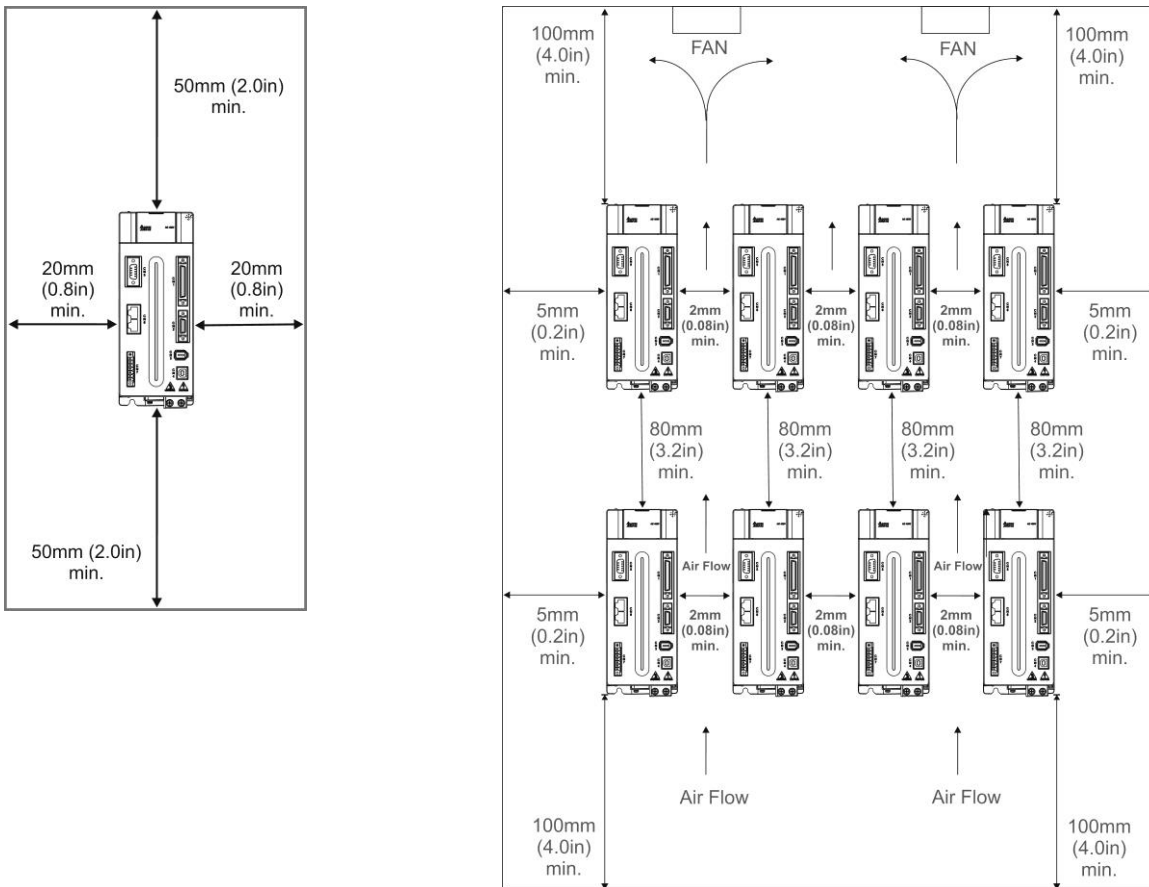

Note: the above diagrams are not in equal proportion. Please refer to the annotation.

2.5 Specification of Circuit Breaker and Fuse

Caution: Please use the fuse and circuit breaker that is recognized by UL/CSA.

Servo Drive Model Operation Mode	Circuit breaker General	Fuse (Class T) General
ASD-A2R-0121-□	5A	5A
ASD-A2R-0221-□	5A	5A
ASD-A2R-0421-□	10A	10A
ASD-A2R-0721-□	10A	20A
ASD-A2R-1021-□	15A	25A
ASD-A2R-1521-□	20A	40A
ASD-A2R-2023-□	30A	50A
ASD-A2R-3023-□	30A	70A

Note: if the servo drive equips with earth leakage circuit breaker for avoiding electric leakage, please choose the current sensitivity which is over 200mA and can continue up to 0.1 seconds.

2.6 EMI Filters Selection

220 V

Item	Power	Servo Drive Model	EMI Filter Model		FootPrint
			1PH	3PH	
1	100 W	ASD-A2R-0121-□	RF007S21AA	RF022B43AA	N
2	200 W	ASD-A2R-0221-□	RF007S21AA	RF022B43AA	N
3	400 W	ASD-A2R-0421-□	RF007S21AA	RF022B43AA	N
4	750 W	ASD-A2R-0721-□	RF007S21AA	RF037B43BA	N
5	1000 W	ASD-A2R-1021-□	RF007S21AA	RF037B43BA	N
6	1500 W	ASD-A2R-1521-□	RF015B21AA	RF037B43BA	N
7	2000 W	ASD-A2R-2023-□	-	RF037B43BA	N
8	3000 W	ASD-A2R-3023-□	-	RF037B43BA	N

EMI Filter Installation

All electronic equipment (including servo drive) generates high or low frequency noise during operation and interfere the peripheral equipments via conduction or radiation. With EMI Filter and the correct installation, much interference can be eliminated. It is suggested to use Delta's EMI Filter to suppress the interference better.

When installing servo drive and EMI Filter, please follow the instructions of the user manual and make sure it meets the following specification.

1. EN61000-6-4 (2001)
2. EN61800-3 (2004) PDS of category C2
3. EN55011+A2 (2007) Class A Group 1

General Precaution

In order to ensure the best performance of EMI Filter, apart from the instructions of servo drive installation and wiring, please follow the precautions mention below:

1. The servo drive and EMI Filter should be installed on the same metal plate.
2. When installing servo drive and EMI Filter, the servo drive should be installed above the EMI Filter.
3. The wiring should be as short as possible.
4. The metal plate should be well grounded.
5. The metal cover of the servo drive and EMI Filter or grounding should be firmly fixed on the metal plate. Also, the contact area should be as large as possible.

Motor Cable Selection and Installation Precautions

The selection of motor cables and installation affect the performance of EMI Filter. Please follow the precautions mention below.

1. Use the cable that has braid shielding (The effect of double shielding is better)
2. The shield on both sides of the motor cable should be grounded in the shortest distance and the largest contact area.
3. The protective paint of the U-shape saddle and metal plate should be removed in order to ensure the good contact. Please see diagram 1.
4. It should have correct connection between the braid shielding of the motor cable and the metal plate. The braid shielding on both sides of the motor cable should be fixed by the U-shape saddle and metal plate. Please see diagram 2 for the correct connection.

Remove the paint on metal saddle to ensure the good grounding

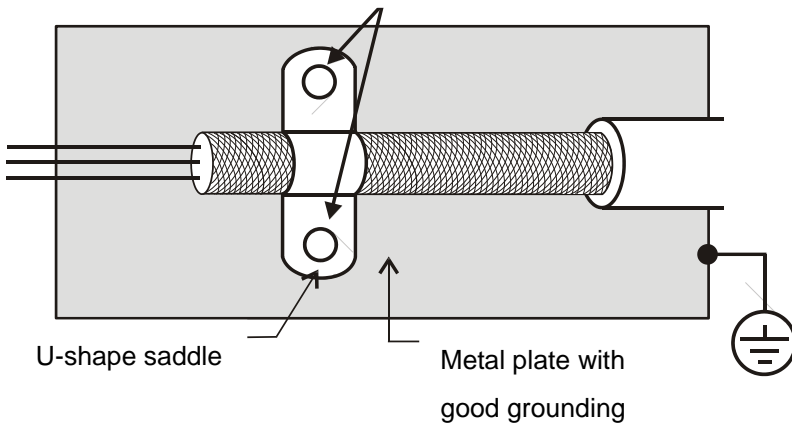

Diagram 1

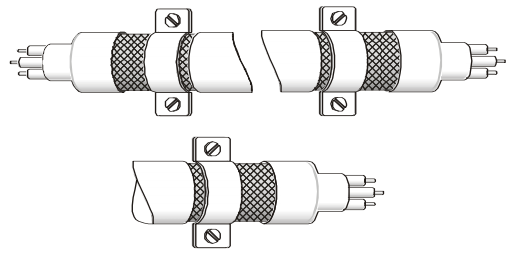

Diagram 2

2.7 Selection of Regenerative Resistor

When the direction of pull-out torque is different from the rotation, it means the electricity is sent back to the servo drive from the load-end. It becomes the capacitance of DC Bus and increases the voltage. When the voltage increases to a specific value, the come-back electricity can only be consumed by regenerative resistor. There is a built-in regenerative resistor in the servo drive. Users can also use the external regenerative resistor if needed.

Specification of built-in regenerative resistor provided by ASDA-A2R

Servo Drive (kW)	Specification of built-in regenerative resistor		*1 The capacity of built-in regenerative resistor (Watt)	Minimum allowable resistance (Ohm)
	Resistance (P1-52) (Ohm)	Capacity (P1-53) (Watt)		
0.1	-	-	-	30
0.2	-	-	-	30
0.4	40	40	20	30
0.75	40	60	30	20
1.0	40	60	30	20
1.5	40	60	30	20
2.0	20	100	50	10
3.0	20	100	50	10

When the regenerative resistor exceeds the capacity of built-in regenerative resistor, the external regenerative resistor should be applied. Please pay special attention to the followings when using the regenerative resistor.

1. Please correctly set up the resistance (P1-52) and capacity (P1-53) of regenerative resistor. Or it might influence the performance of this function.
2. If users desire to use the external regenerative resistor, please make sure the applied value is the same as the built-in regenerative resistor. If users desire to connect it in parallel to increase the power of regenerative resistor, please make sure the capacitance meets the requirements.
3. In natural environment, if the capacity of regenerative resistor (the average value) is within the rated capacity, the temperature of the capacitance will increase to 120°C or even higher (under the condition of regenerative energy keeps existing). For safety concerns, please apply the method of forced cooling in order to reduce the temperature of regenerative resistor. Or, it is suggested to use the regenerative resistor which is equipped with thermal switches. Please contact the distributors for load characteristics of the regenerative resistor.

When using the external regenerative resistor, the resistor should connect to P, C terminal and the contact of P, D terminal should be opened. It is recommended to choose the above mentioned capacitance. For easy calculation of regenerative resistor capacity, except the energy consumed by IGBT, two ways are provided to select the capacity of external regenerative resistor according to the selected linear motor or rotary motor.

Rotary Motor:

(1) Regenerative Power Selection

(a) When the external load on torque does not exist

If the motor operates back and forth, the energy generated by the brake will go into the capacitance of DC bus. When the voltage of the capacitance exceeds a specific value, the redundant energy will be consumed by regenerative resistor. Two ways of selecting regenerative resistor are provided here. The table below provides the energy calculation method. Users can refer to it and calculate the selected regenerative resistor.

Servo Drive (kW)	Motor	Rotor Inertia J ($\times 10^{-4}$ kg.m ²)	Regenerative power from empty load 3000r/min to stop Eo (joule)	The maximum regenerative power of capacitance Ec (joule)
Low Inertia	0.05 ECMA-C1040F□ □	0.021	0.10	4.21
	0.1 ECMA-C10401□ □	0.037	0.18	4.21
	0.2 ECMA-C10602□ □	0.177	0.87	5.62
	0.4 ECMA-C10604□ □	0.277	1.37	8.42
	0.4 ECMA-C10804□ □	0.68	3.36	8.42
	0.75 ECMA-C10807□ □	1.13	5.59	17.47
	1.0 ECMA-C11010□ □	2.65	13.10	21.22
	2.0 ECMA-C11020□ □	4.45	22.0	25.58
	3.0 ECMA-C11330□ □	12.7	62.80	25.58
Medium Inertia	0.4 ECMA-E11305□ □	8.17	40.40	8.42
	1.0 ECMA-E11310□ □	8.41	41.59	21.22
	1.5 ECMA-E11315□ □	11.18	55.29	25.58
	2.0 ECMA-E11320□ □	14.59	72.15	25.58
	2.0 ECMA-E11820□ □	34.68	171.49	25.58
	3.0 ECMA-E11830□ □	54.95	271.73	31.20
	3.5 ECMA-E11835□ □	54.95	271.73	31.20
Medium-High Inertia	0.85 ECMA-F11308□ □	14.1	69.73	21.22
	2.0 ECMA-F11313□ □	20.0	98.90	25.58
	2.0 ECMA-F11318□ □	24.9	123.13	31.20
	3.0 ECMA-F11830□ □	54.95	271.73	28
High Inertia	0.75 ECMA-F11305□ □	10.3	22.64	17.47

Assume the load inertia is N times to the motor inertia and the motor decelerates from 3000r/min to 0, its regenerative energy is $(N+1) \times E_o$. The consumed regenerative resistor is $(N+1) \times E_o - E_c$ joule. If the cycle of back and forth operation is T sec, then the power of regenerative resistor it needs is $2 \times ((N+1) \times E_o - E_c) / T$.

Followings are the calculation procedure:

Steps	Item	Calculation and Setting Method
1	Set the capacity of regenerative resistor to the maximum	Set P1-53 to the maximum value
2	Set T cycle of back and forth operation	Enter by the user
3	Set the rotational speed w_r	Enter by the user or read via P0-02
4	Set the load/motor inertia ratio N	Enter by the user or read via P0-02
5	Calculate the maximum regenerative energy E_o	$E_o = J * w_r^2 / 182$
6	Set the absorbable regenerative energy E_c	Refer to the above table
7	Calculate the needful capacitance of regenerative resistor	$2 \times ((N+1) \times E_o - E_c) / T$

Take 400W as the example, the cycle of back and forth operation is $T = 0.4$ sec, the maximum speed is 3000r/min and the load inertia is 7 times to the motor inertia. Then, the needful power of regenerative resistor is $2 \times ((7+1) \times 1.68 - 8) / 0.4 = 27.2$ W. If it is smaller than the built-in capacity of regenerative resistor, the built-in 60W regenerative resistor will do. Generally speaking, when the need of the external load inertia is not much, the built-in regenerative is enough. The diagram below describes the actual operation. The smaller power of the regenerative resistor it is, the more energy it accumulates and the higher temperature it will be. When the temperature is higher than a specific value, ALE05 occurs.

(b) If the external load torque exists, the motor is in reverse rotation.

Usually, the motor is in forward rotation, which means the torque output direction of the motor is the same as the rotation direction. However, in some applications, the direction of torque output is different from the rotation. In this situation, the motor is in reverse rotation. The external energy goes into the servo drive through the motor. The diagram below is one example. When the external force direction is the same as the moving direction, the servo system has to use the force of the opposite direction to keep the speed and stability. Huge amount of energy will return to the servo drive at the moment. When DC-BUS is full and unable to store the regenerative energy, the energy will be leaded to regenerative resistor and consumed.

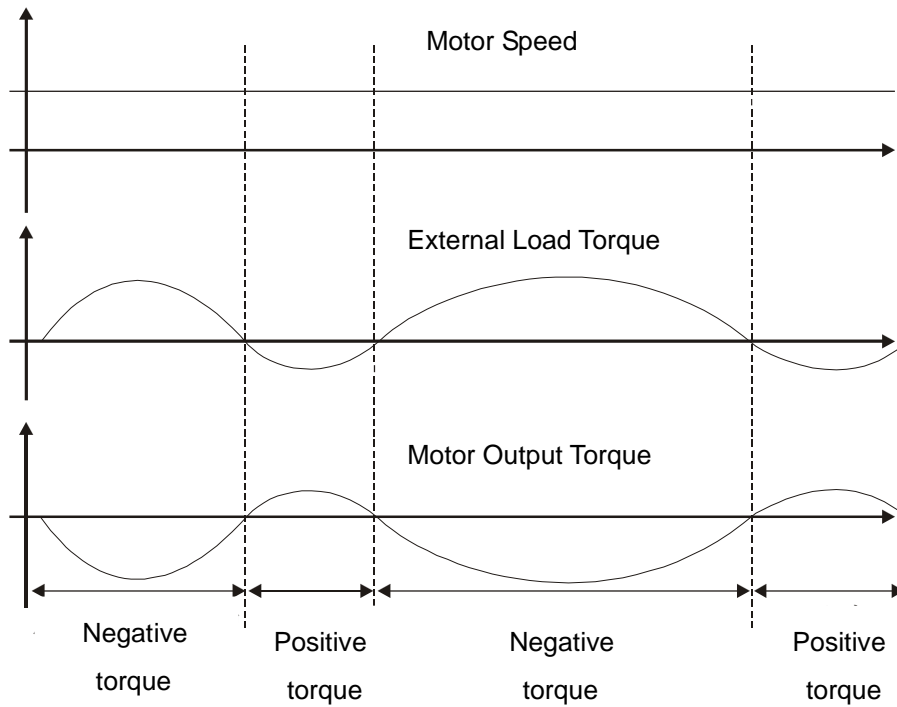

Negative torque: $T_L \times \omega_r$ T_L : external load torque

For safety reasons, please calculate it by considering the safest situation.

For example, when the external load torque is the +70% rated torque and the rotation reaches 3000 r/min, then take 400 W (the rated torque is 1.27 Nt-m) as the example, the user has to connect the regenerative resistor of 40Ω , which is $2 \times (0.7 \times 1.27) \times (3000 \times 2 \times \pi / 60) = 560W$.

(2) Simple Selection

Choose the appropriate regenerative resistor according to the allowable frequency and empty load frequency in actual operation. The so-called empty allowable frequency is the frequency of continuous operation when the servo motor runs from 0r/min to the rated speed and then decelerates from the rated speed to 0r/min within the shortest time. The following table lists the allowable frequency when the servo drive runs without load (times/min).

Allowable frequency of built-in regenerative resistor when the servo drive runs without load (times/min)										
Motor Capacity	600 W	750 W	900 W	1.0 kW	1.5 kW	2.0 kW	2.0 kW	3.0 kW	11 kW	15 kW
Corresponding Motor	06	07	09	10	15	20	20	30	1B	1F
ECMA□ □ C	-	312	-	137	-	83 (F100)	-	-	-	-
ECMA□ □ E	-	-	-	42	32	24 (F130)	10 (F180)	11	-	-
ECMA□ □ F	-	-	-	-	-	-	-	11	-	-
ECMA□ □ G	42	-	31	-	-	-	-	-	-	-
ECMA□ □ L	-	-	-	-	-	-	-	-	-	-

When the servo motor runs with load, the allowable frequency will be different according to different load inertia or speed. The following is the calculation method.
 m represents load / motor inertia ratio.

$$\text{Allowable frequency} = \frac{\text{Allowable frequency when servo motor run without load}}{m + 1} \times \left(\frac{\text{Rated speed}}{\text{Operating speed}} \right)^2 \frac{\text{times}}{\text{min.}}$$

The comparison table of external regenerative resistor is provided below. Please choose the appropriate regenerative resistor according to the allowable frequency. The table below describes the suggested allowable frequency (times/min) of regenerative resistor when the servo drive runs without load.

Allowable frequency of regenerative resistor when the servo drive runs without load (times/min)							
Motor Capacity Recommended regenerative resistor	ECMA□ □ C						
	100 W	200 W	400 W (F60)	400 W (F80)	750 W	1.0 kW	2.0 kW
	01	02	04	04	07	10	20
BR400W040 (400 W 40Ω)	-	-	8608	3506	2110	925	562
BR1K0W020 (1 kW 20Ω)	-	-	-	8765	5274	2312	1406

Motor Capacity Recommended regenerative resistor	ECMA□ □ E					
	0.5 kW	1 kW	1.5 kW	2.0 kW (F130)	2.0 kW (F180)	3.0 kW
	05	1.0	15	20	20	30
BR400W040 (400 W 40Ω)	291	283	213	163	68	-
BR1K0W020 (1 kW 20Ω)	729	708	533	408	171	-
BR1K5W005 (3 kW 10Ω)	-	-	-	-	-	331

Allowable frequency of regenerative resistor when the servo drive runs without load (times/min)	
Motor Capacity Recommended regenerative resistor	ECMA□ □ F
	3.0 kW
	30
BR1K5W005 (3 kW 10Ω)	331

Allowable frequency of regenerative resistor when the servo drive runs without load (times/min)		
Recommended regenerative resistor	Motor Capacity	ECMA□ □ L
		11 kW
		15 kW
		1B
		1F
BR400W040 (400 W 40Ω)	-	-
BR1K0W020 (1 kW 20Ω)	-	-

Linear Motor:

Regenerative Power Selection

(a) When the external load on torque does not exist

If the motor operates back and forth, the energy generated by the brake will go into the capacitance of DC bus. When the voltage of the capacitance exceeds a specific value, the redundant energy will be consumed by regenerative resistor. Two ways of selecting regenerative resistor are provided here. The table below provides the energy calculation method. Users can refer to it and calculate the selected regenerative resistor.

Servo Drive (kW)	Motor	Three times of coil weight (coil assembly) m (kg)	Regenerative power from empty load 5m/s to stop Eo (joule)	The maximum regenerative power of capacitance Ec (joule)
0.1	ECML-S1606A2DNS	1.05	13.125	4.21
	ECML-S1608A2DNS	1.35	16.875	4.21
0.2	ECML-S2003A2DNS	1.95	24.375	5.62
	ECML-S2004A2DNS	2.49	31.125	5.62
	ECML-S2005A2DNS	3	37.5	5.62
0.4	ECML-S2504A2DNS	3.3	41.25	8.42
	ECML-S2506A2DNS	4.8	60	8.42
	ECML-S3204A2DNS	6.3	78.75	8.42
0.75	ECML-S2508A2DNS	4.5	56.25	17.47
	ECML-S3206A2DNS	6.6	82.5	17.47
	ECML-S3208A2DNS	8.4	105	17.47

Assume the total weight of movable section and load is m kg, when v m/s decelerates to 0, its regenerative energy is $E = 0.5 mv^2$ (joule) and the consumed regenerative resistor is $E - E_c$ joule. If the cycle of back and forth operation is T sec, then the power of regenerative resistor it needs is $2 \times (E - E_c) / T$. Followings are the calculation procedure:

Steps	Item	Calculation and Setting Method
1	Set the capacity of regenerative resistor to the maximum	Set P1-53 to the maximum value
2	Set T cycle of back and forth operation	Enter by the user
3	Set up the speed v	Enter by the user or read via P0-02
4	Set up the total weight of movable section and load, N	Enter by the user or read via P0-02
5	Calculate the maximum regenerative energy E	$E = 0.5 mv^2$
6	Set the absorbable regenerative energy E_c	Refer to the above table
7	Calculate the needful capacitance of regenerative resistor	$2 \times (E - E_c) / T$

Take 400W as the example, the cycle of back and forth operation is $T = 0.4$ sec, assume that the maximum speed is 2m/s and the total weight of movable section and load is 7kg, the needful power of regenerative resistor is $2 \times (0.5 \times 7 \times 2^2 - 8.42) / 0.4 = 27.9$ W. If it is smaller than the built-in capacity of regenerative resistor, the built-in 60W regenerative resistor will do. Generally speaking, when the need of movable section and the external load inertia is not much, the built-in regenerative is enough. The diagram below describes the actual operation. The smaller power of the regenerative resistor it is, the more energy it accumulates and the higher temperature it will be. When the temperature is higher than a specific value, ALE05 occurs.

(b) When the external load torque exists, the motor is in reverse rotation.

Usually, the motor is in forward rotation, which means the force direction of the motor is the same as the moving direction. However, in some applications, the direction of force is different from the moving direction. In this situation, the motor is in reverse rotation. The external energy goes into the servo drive through the motor. The diagram below is one of the examples. When the motor is in constant speed, it is positive force in most of the time and a huge amount of energy rapidly transmits to regenerative resistor.

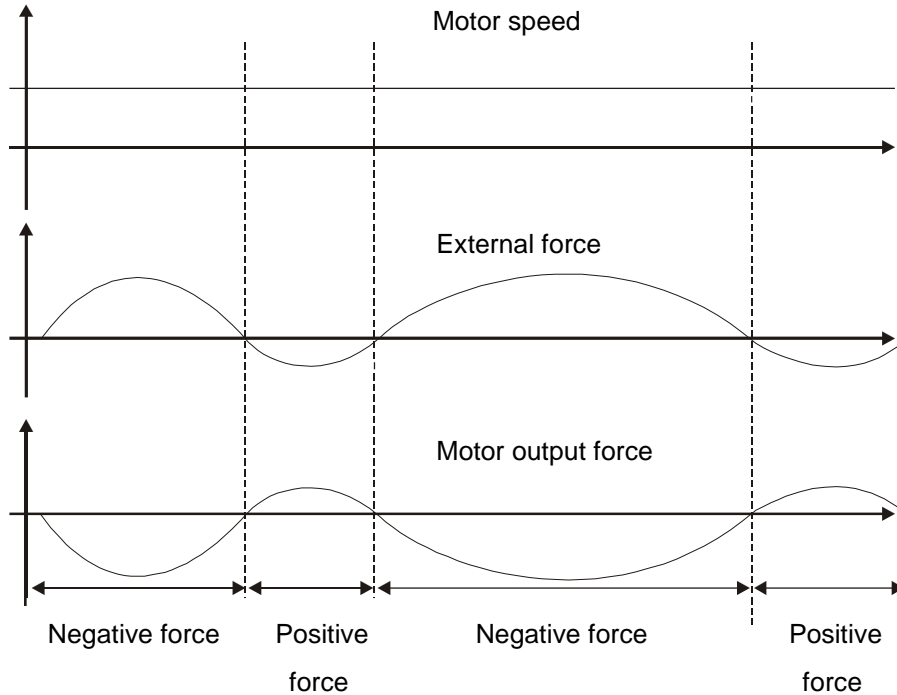

Negative force: $TL \times Wr$ TL : external force

For safety reasons, please calculate it by considering the safest situation.

For example, when the external force is the +70% rated force and the speed reaches 2m/s, then take 400W (rated force is FN) as the example, the user has to connect the regenerative resistor which is $2 \times (0.7 \times F) \times (2) = 2.8 * F W, 40\Omega$.

(2) Simple Selection

Choose the appropriate regenerative resistor according to the allowable frequency and empty load frequency in actual operation. The so-called empty allowable frequency is the maximum frequency of continuous operation when the servo motor runs from 0m/s to 5m/s and then from 5m/s to 0r/min. The following table lists the allowable frequency of built-in regenerative resistor when the servo drive runs without load (times/min).

Motor Capacity Corresponding Motor	400 W	400 W	400 W	750 W	750 W	750 W
	04	06	08	04	06	08
ECML-S25□□A2DNS	87	60	45	-	-	-
ECML-S32□□A2DNS	-	-	-	96	65	51

When the servo motor runs with load, the allowable frequency will be different according to different load inertia or speed. The following is the calculation method.

Allowable frequency

$$= \text{allowable frequency without load} \times \frac{\text{coil weight}}{\text{load weight}} \times \left(\frac{5\text{m/s}}{\text{speed}}\right)^2 (\text{times/min})$$

The comparison table of external regenerative resistor is provided below. Please choose the appropriate regenerative resistor according to the allowable frequency. The table below describes the suggested allowable frequency (times/min) of regenerative resistor when the servo drive runs without load.

Allowable frequency of regenerative resistor when the servo drive runs without load (times/min)							
Recommended regenerative resistor	Motor Capacity	ECML-S25□ □ A2DNS					
	400 W	400 W	400 W	750 W	750 W	750 W	
	04	06	08	04	06	08	
BR400W040 (400 W 40Ω)	872	600	457	-	-	-	
BR1K0W020 (1 kW 20Ω)	-	-	-	-	-	-	

Recommended regenerative resistor	Motor Capacity	ECML-S32□ □ A2DNS					
	400 W	400 W	400 W	750 W	750 W	750 W	
	04	06	08	04	06	08	
BR400W040 (400 W 40Ω)	-	-	-	640	436	342	
BR1K0W020 (1 kW 20Ω)	-	-	-	1600	1090	855	

If watt is not enough when using regenerative resistor, connecting the same regenerative resistor in parallel can increase the power.

Dimensions of Regenerative Resistor

Delta part number: BR400W040 (400 W 40Ω)

L1	L2	H	D	W	MAX. WEIGHT (g)
265	250	30	5.3	60	930

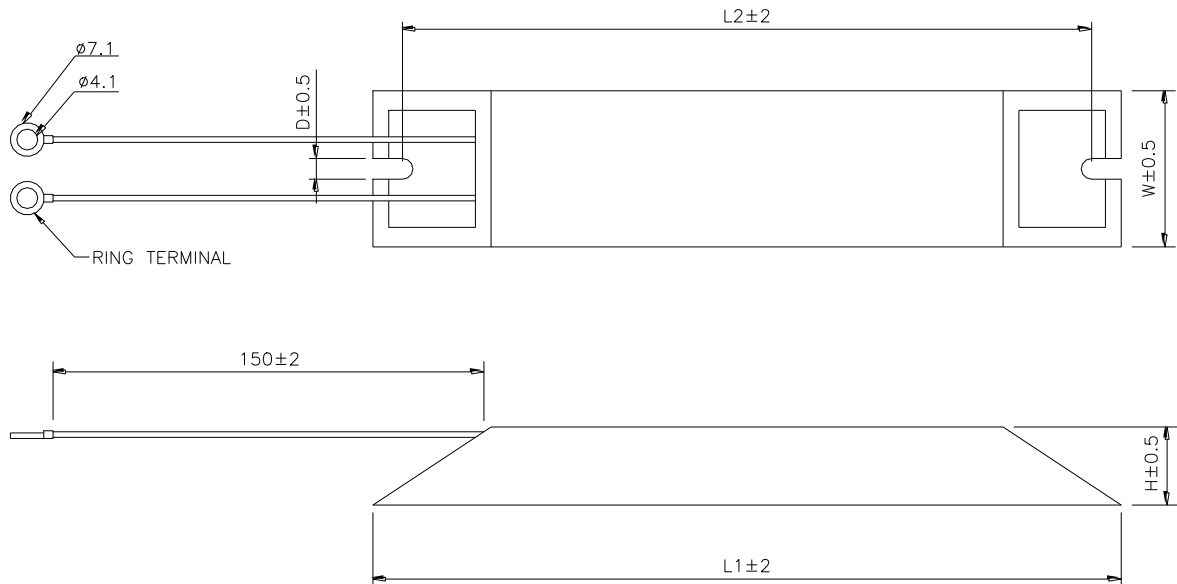

Delta part number: BR1K0W020 (1 kW 20Ω)

A	B	C	D	E	F	G	ØH	ØI
470	445	48	9.1	98	47	15	55	8.1

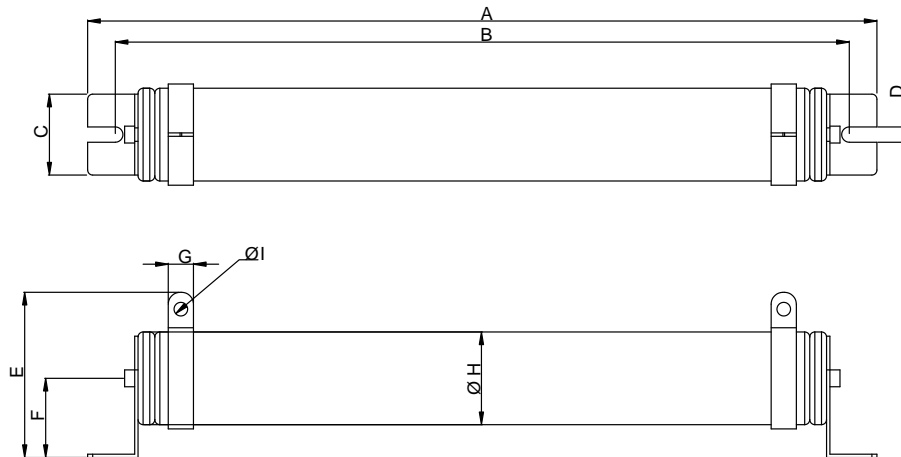

Delta part number: BR1K5W005 (3 kW 10Ω)

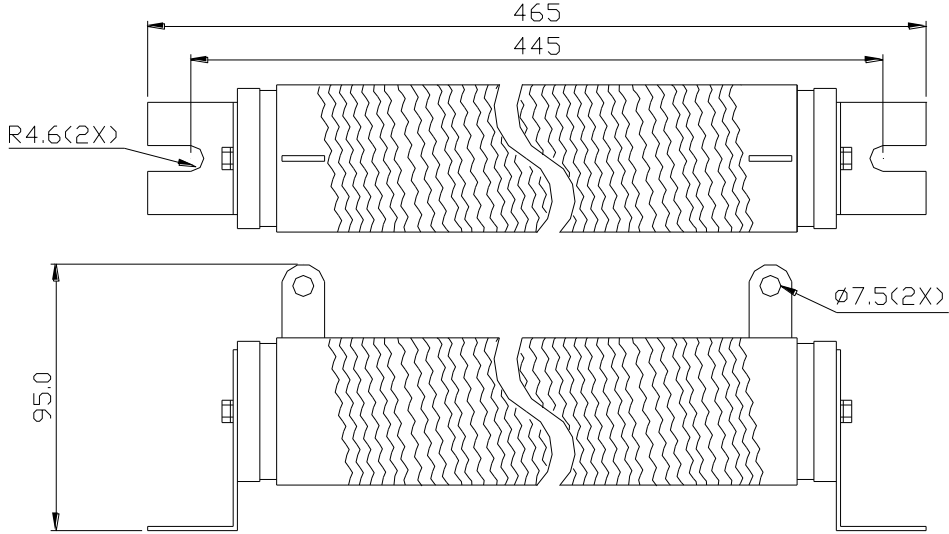

(This page is intentionally left blank.)

Chapter 3 Wiring

This chapter details the wiring method of servo drive, the definition of each signal and standard wiring diagram.

3.1 Wiring of Delta's Servo System

3.1.1 Wiring Diagram of Peripheral Devices (connect to Delta's Servo Motor (Communication Type))

Installation Notes:

1. Check if the power and wiring among R, S, T and L1c, L2c are correct.
2. When connecting to Delta's 20bit rotary motor, please check if the output terminal U, V, W of the servo motor is correctly wired. The incorrect wiring may disable the operation of the motor or cause malfunction.
3. When applying to the external regenerative resistor, the contact between P⁺ and D should be opened and the external regenerative resistor should connect to terminal P⁺ and C. When applying to the internal regenerative resistor, the contact between P⁺ and D should be closed and the contact between P⁺ and C should be opened.
4. When an alarm occurs or the system is in emergency stop status, use ALARM or WARN to output and disconnect the power of magnetic contactor in order to disconnect the power of servo drive.

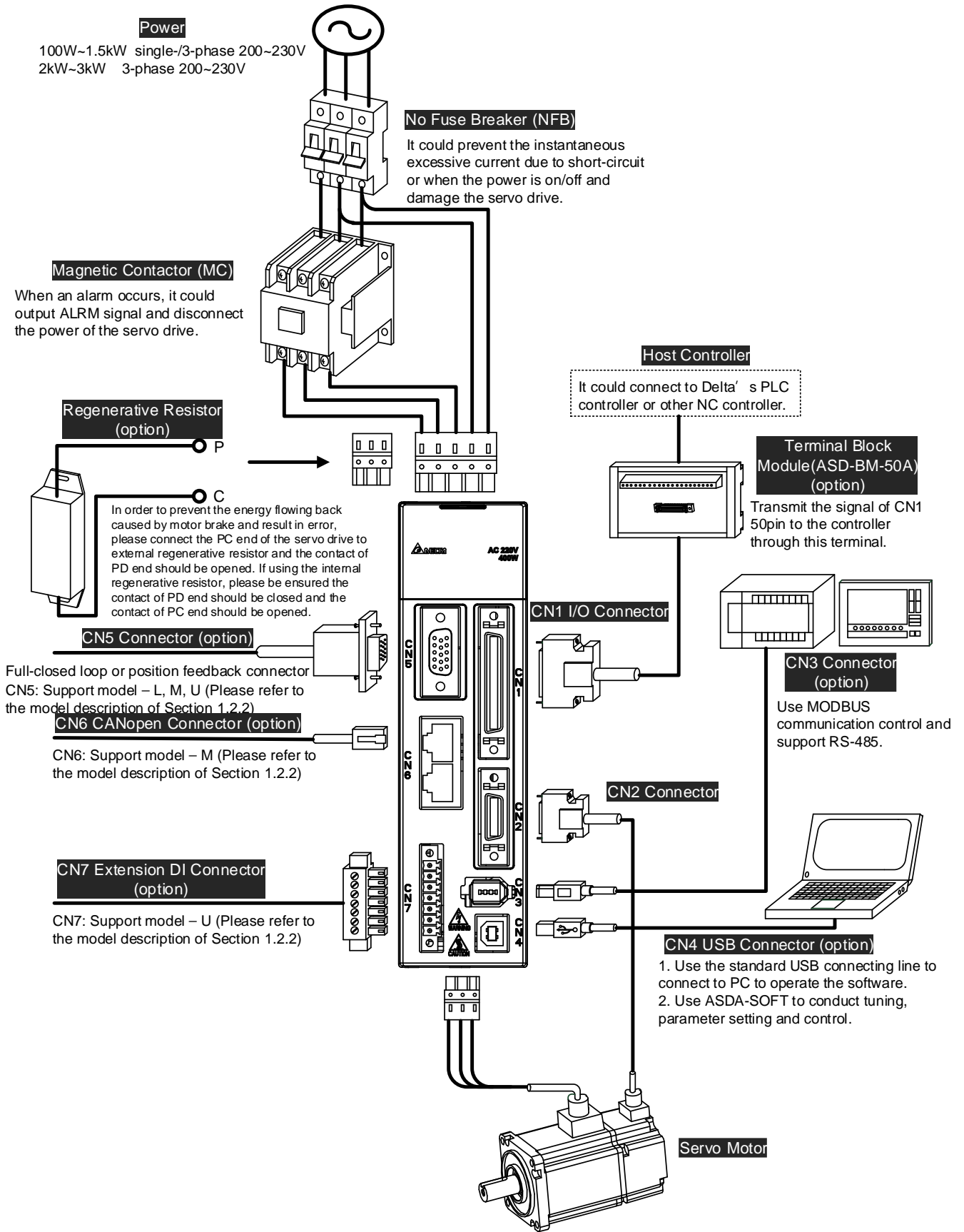

3.1.2 Connectors and Terminals of the Servo Drive

Terminal Signal	Name	Description		
L1c, L2c	Power input of the control circuit	Connect to single-phase AC power (select the appropriate voltage specification according to the product).		
R, S, T	Power input of the main circuit	Connect to three-phase AC power (select the appropriate voltage specification according to the product).		
U, V, W FG	Motor cable	Connect to the motor		
		Terminal Symbol	Wire Color	Description
		U	Red	Three-phase main power cable of the motor
		V	White	
		W	Black	
FG	Green	Connect to the grounding \oplus of the servo drive.		
P ⁺ , D, C, \ominus	Regenerative resistor terminal or brake unit	Use internal resistor	The contact between P ⁺ and D end should be closed; contact between P ⁺ and C end should be opened.	
		Use external resistor	Connect P ⁺ , C ends to the resistor and the contact between P ⁺ and D end should be opened.	
		Use external braking unit	P ⁺ and P ⁻ of the brake unit should connect to P ⁺ and P ⁻ respectively. The contact between P ⁺ and D and P ⁺ and C should be opened.	
\oplus	Ground terminals	Connect to the ground wire of the power and the servo motor.		
CN1	I/O connector (option)	Connect to the host controller, please refer to Section 3.3.		
CN2	Connector (option)	Connect to the encoder of the motor, please refer to Section 3.4.		
CN3	Connector (option)	Connect to RS-485, please refer to Section 3.5.		
CN4	USB connector (Type B) (option)	Connect to personal computer (PC or NOTEBOOK), please refer to Section 3.6		
CN5	Connector (option)	Connect to linear scale or encoder for full-closed loop and motor feedback. Please refer to Section 3.7.		
CN6	CANopen connector (option)	RJ45 connector, please refer to Section 3.8.		
CN7	Extension DI connector (option)	Extension DI connector. Please refer to 3.9.		
CN8	Battery connector	Connector for absolute type of battery box.		

Pay special attention to the followings when wiring:

- 1) When the power is cutoff, do not touch R, S, T and U, V, W since the capacitance inside the servo drive still contains huge amount of electric charge. Wait until the charging light is off.
- 2) Separate R, S, T and U, V, W from the other wires. The interval should be at least 30 cm (11.8 inches).
- 3) If the wire of encoder CN2 or CN5 connector is not long enough, please use shielded twisted-pair cable which cannot exceed 20 meters (65.62 inches). If it exceeds 20 meters, please choose the bigger wire diameter of signal cable to ensure it will not cause signal fading. As for the encoder wiring specification of 20-meter-long cable, please use AWG26 of wire size and metal braided shield twisted-pair cable which complies with the standard of UL 2464.
- 4) When using CANopen, please use the standard shielded twisted-pair cables to ensure the communication quality.
- 5) When selecting the wire rod, please refer to Section 3.1.6.

3.1.3 Wiring Method

The wiring method of ASDA-A2R servo drive is divided into single-phase and three-phase. In the diagram below, Power On is contact **a**, Power Off and ALRM_RY are contact **b**. MC is the coil of magnetic contactor and self-remaining power and is the contact of main power circuit.

- Wiring Method of Single-phase Power Supply (suitable for 1.5 kW and models below 1.5 kW)

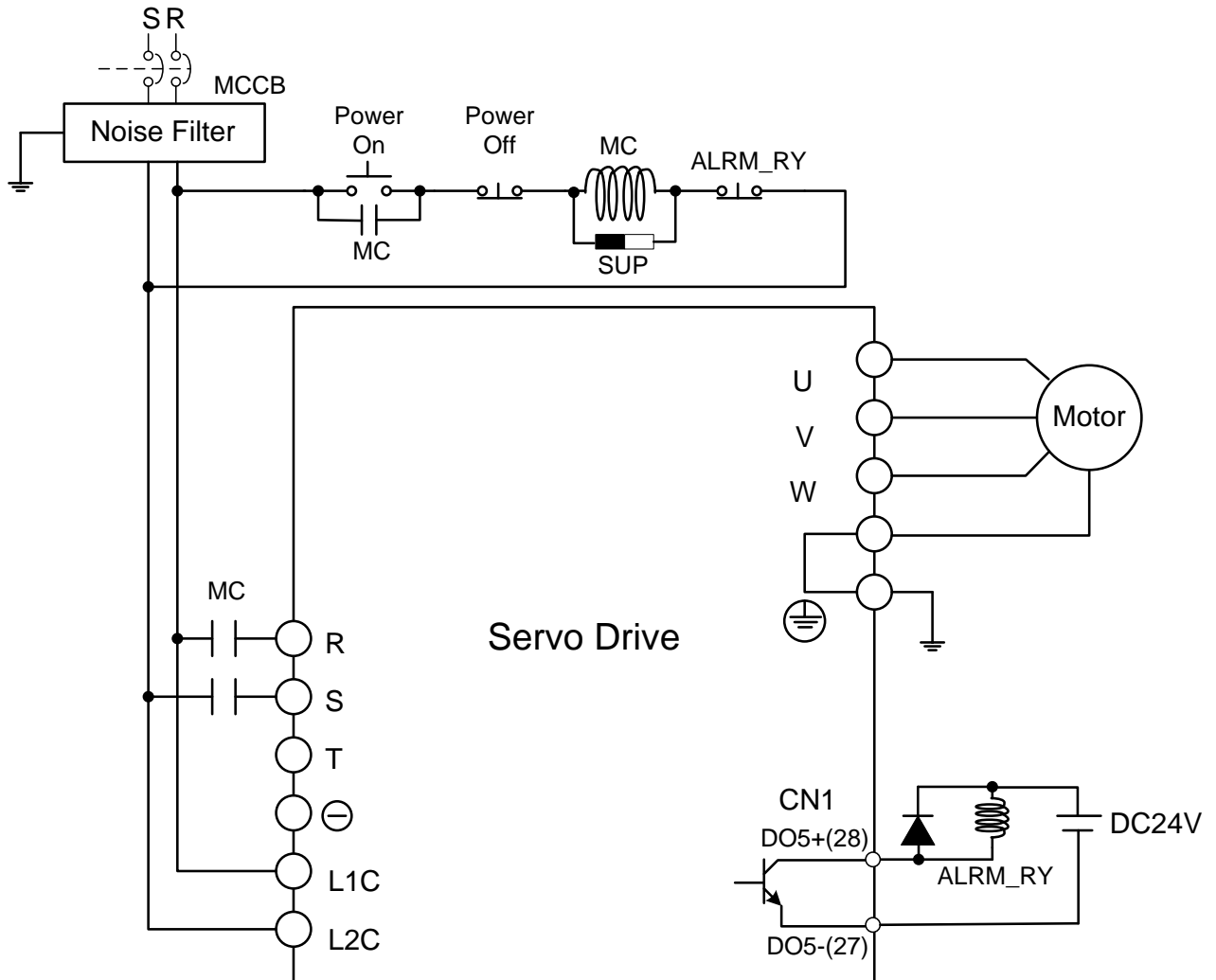

■ Wiring Method of Three-phase Power Supply (suitable for all series)

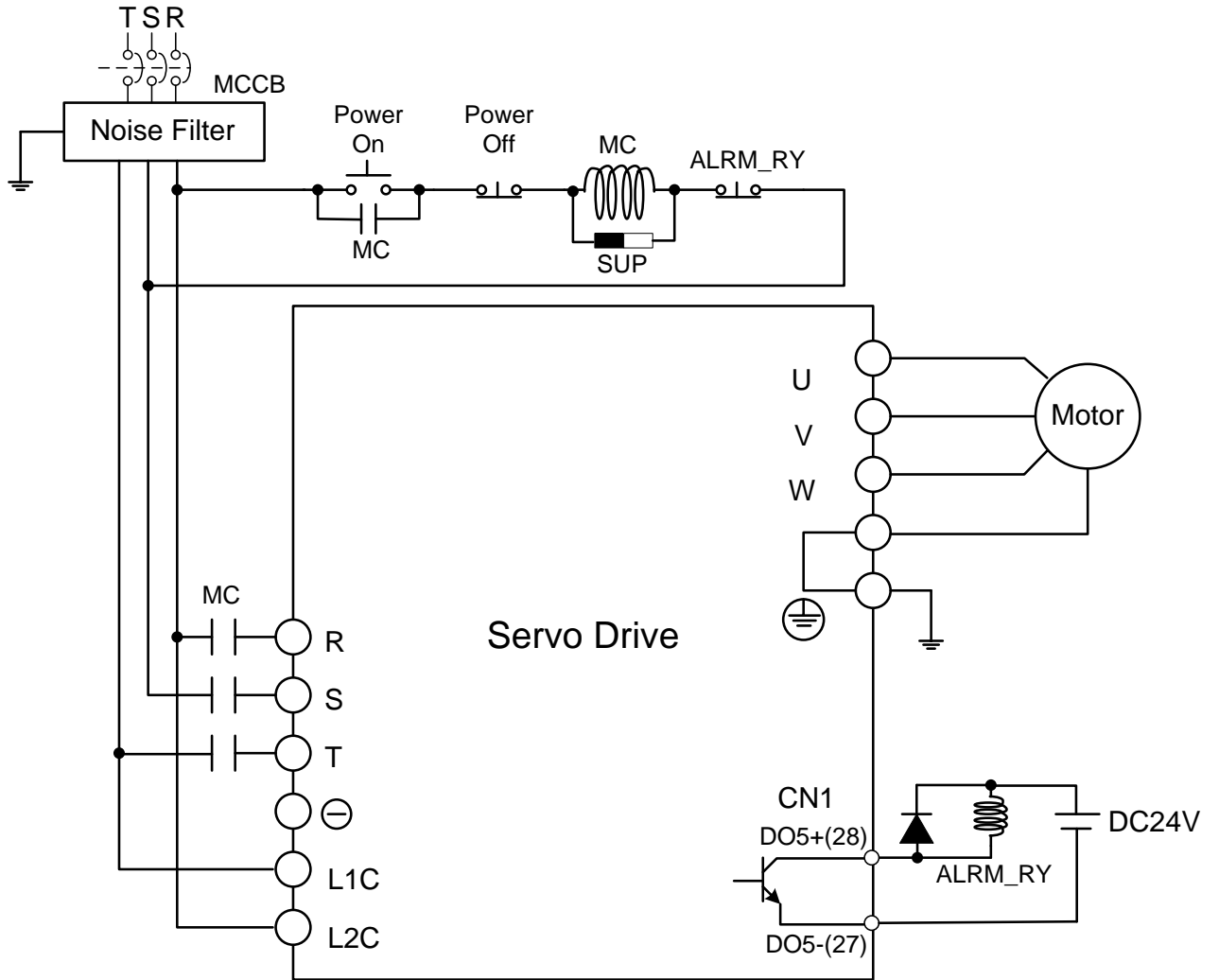

3.1.4 Specification of ECMA Motor U, V, W Power Cable

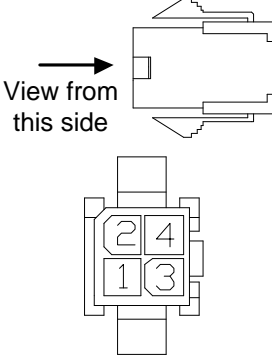
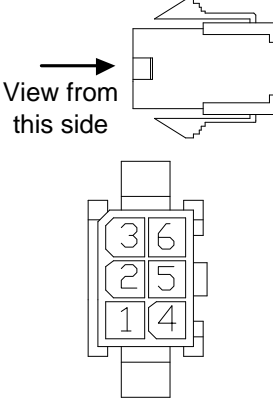
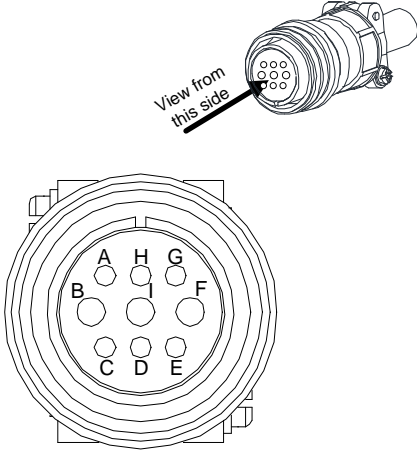
Motor Model	U, V, W / Connector of Brake	Terminal Definition
<p>ECMA-C1040F□S (50 W) ECMA-C△0401□S (100 W) ECMA-C△0602□S (200 W) ECMA-C△0604□S (400 W) ECMA-C△0804□7 (400 W) ECMA-C△0807□S (750 W) ECMA-C△0907□S (750 W) ECMA-C△0910□S (1000 W)</p>	<p style="text-align: center;">  </p> <p style="text-align: center;">HOUSING: JOWLE (C4201H00-2*2PA)</p>	A
<p>ECMA-C1040F□S (50 W) ECMA-C△0401□S (100 W) ECMA-C△0602□S (200 W) ECMA-C△0604□S (400 W) ECMA-C△0804□7 (400 W) ECMA-C△0807□S (750 W) ECMA-C△0907□S (750 W) ECMA-C△0910□S (1000 W)</p> <p>*□ : with brake</p>	<p style="text-align: center;">  </p> <p style="text-align: center;">HOUSING : JOWLE (C4201H00-2*3PA)</p>	B
<p>ECMA-G△1303□S (300 W) ECMA-E△1305□S (500 W) ECMA-F11305□S (500 W) ECMA-G△1306□S (600 W) ECMA-F△1308□S (850 W) ECMA-G△1309□S (900 W) ECMA-C△1010□S (1000 W) ECMA-E△1310□S (1000 W) ECMA-F11313□S (1300 W) ECMA-E△1315□S (1500 W) ECMA-F11318□S (1800 W) ECMA-C△1020□S (2000 W) ECMA-E△1320□S (2000 W) ECMA-C△1330□4 (3000 W)</p>	<p style="text-align: center;">  </p> <p style="text-align: center;">3106A-20-18S</p>	C

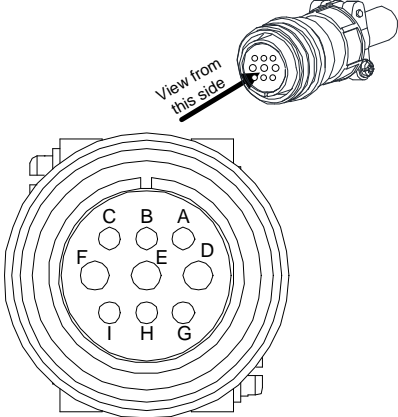
Motor Model	U, V, W / Connector of Brake	Terminal Definition
ECMA-E△1820□S (2000 W) ECMA-E△1830□S (3000 W) ECMA-E△1835□S (3500 W) ECMA-F△1830□S (3000 W)	 <p>3106A-24-11S</p>	D

Wiring Name	U (Red)	V (White)	W (Black)	CASE GROUND (Green)	BRAKE1 (Yellow)	BRAKE2 (Blue)
Terminal Definition A	1	2	3	4	-	-
Terminal Definition B	1	2	4	5	3	6
Terminal Definition C	F	I	B	E	G	H
Terminal Definition D	D	E	F	G	A	B

When selecting the wire rod, please choose 600V PVC cable and the length should not longer than 30m. If the length exceeds 30m, please take the received voltage into consideration when selecting the wire size. Please refer to Section 3.1.6 for wire rod selection.

Note:

- 1) No polarity for brake coil, the wiring name is BRAKE1 & BRAKE2.
- 2) Power for brake is DC24 V. Never share it with the power of control signal VDD.
- 3) Box, (△) in servo motor model represents encoder type. △=1: incremental, 20-bit; △=2: incremental, 17-bit; △=A: absolute.
- 4) Box, (□) in servo motor model represents brake or keyway / oil seal.

Specification of ECML Motor U, V, W Power Cable

Motor Model	Color	Definition	AWG
ECML-S16□□□□□□S ECML-S20□□□□□□S	Red	U phase circuit cable	20
	White	V phase circuit cable	20
	Black	W phase circuit cable	20
	Green	Motor grounding and shielded net	20
ECML-S25□□□□□□S ECML-S32□□□□□□S	Red	U phase circuit cable	18
	White	V phase circuit cable	18
	Black	W phase circuit cable	18
	Green	Motor grounding and shielded net	18

Note:

- 1) U, V, W are the bare wire, which has no connector and terminal.
- 2) The total length of standard cable is 500mm.
- 3) The cover of the green grounding cable is heat-shrink tubing. If users cut off the grounding cable and re-connect it, please connect it to the shielded net for better noise separation.

3.1.5 Specification of Connector of Encoder Cable

Encoder connection diagram 1:

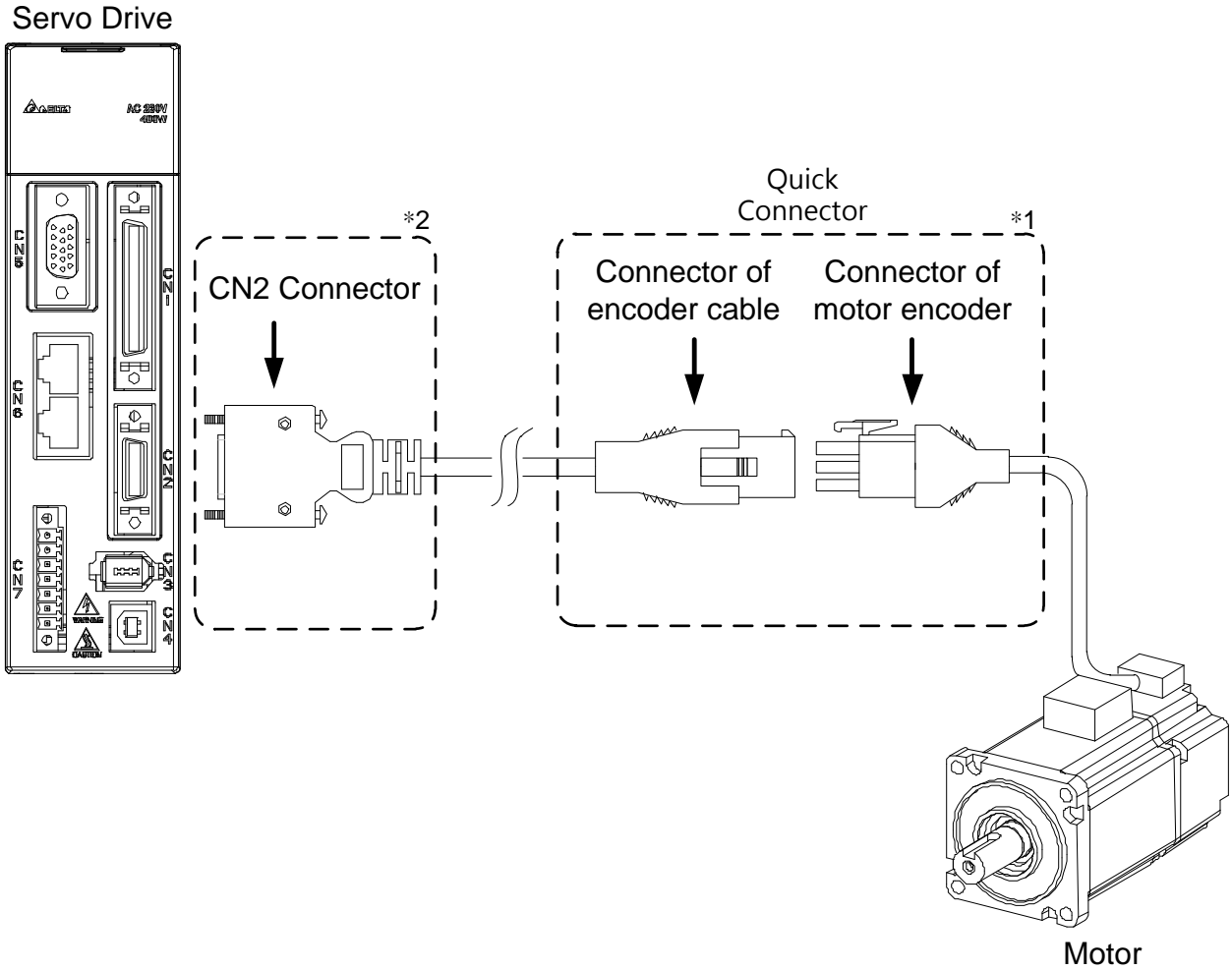

Note: this diagram shows the connection between the servo drive and the motor encoder. It is not drawn by the practical scale and specification will be different according to the selected servo drive and motor model.

- 1) Please refer to the Section of Specification and Definition of Encoder Connector.
- 2) Please refer to Section 3.5 CN2 Connector.

Motor Model	Connector of Encoder Cable
ECMA-C1040F□S (50 W) ECMA-C△0401□S (100 W) ECMA-C△0602□S (200 W) ECMA-C△0604□S (400 W) ECMA-C△0804□7 (400 W) ECMA-C△0807□S (750 W) ECMA-C△0907□S (750 W) ECMA-C△0910□S (1000 W)	<p>HOUSING : AMP (1-172161-9)</p>

Specification and Definition of Encoder Connector:

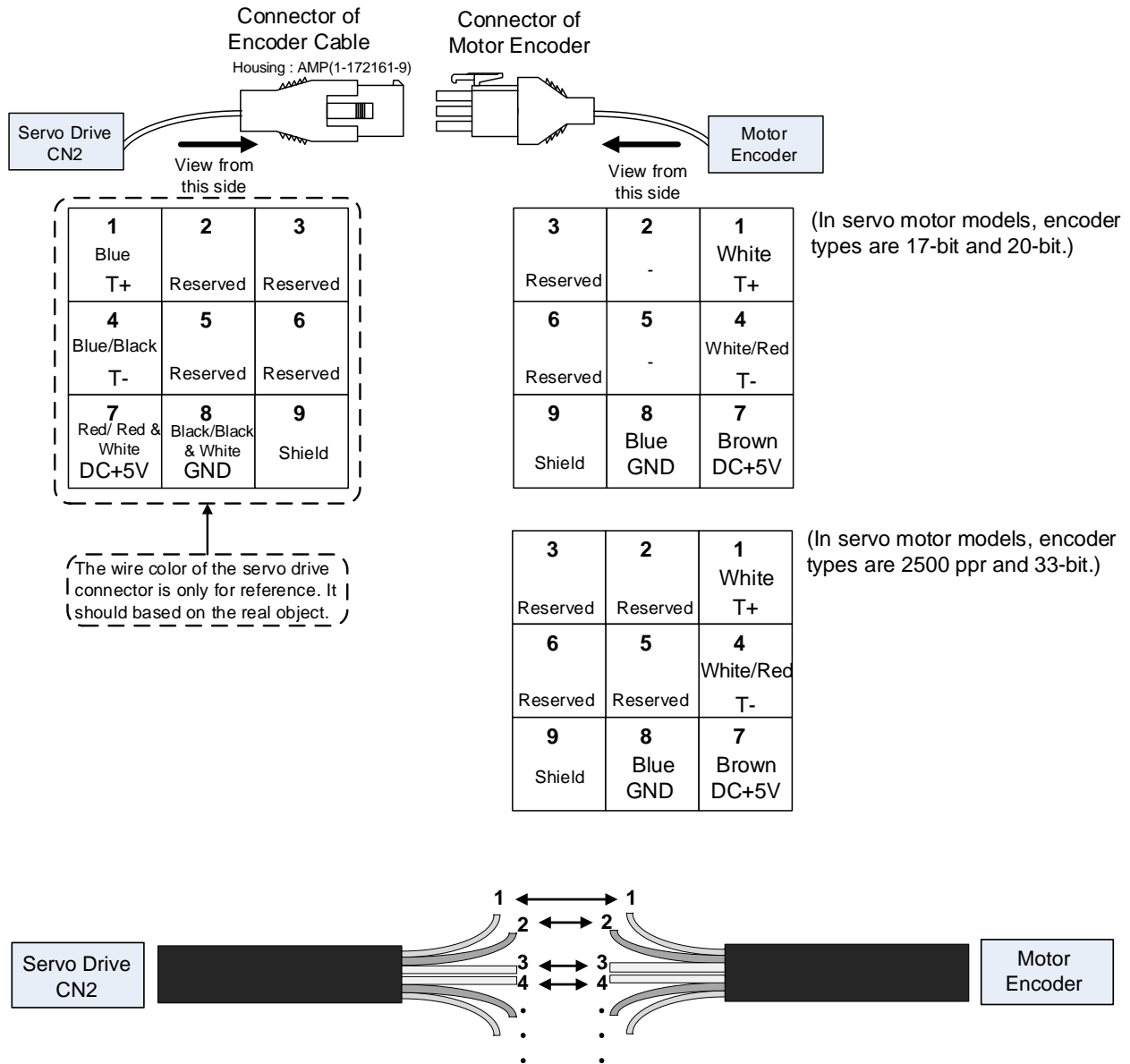

If not using housing and directly wire the cores, please follow the corresponding core number for wiring. For example, core number 1 from the servo drive CN2 should connect to core number 1 from the motor encoder; core number 2 from the servo drive CN2 should connect to core number 2 from the motor encoder and so on. Please number the cores from the servo drive in order and then connect it to the encoder.

Encoder connection diagram 2:

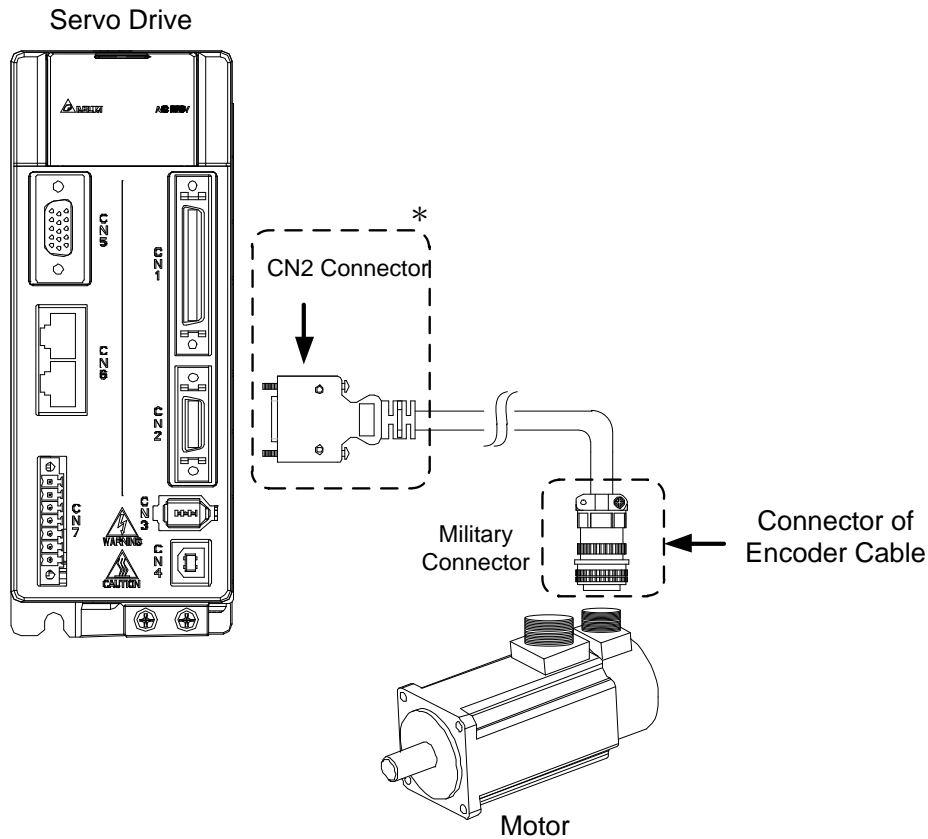

Note: this diagram shows the connection between the servo drive and the motor encoder. It is not drawn by the practical scale and specification will be different according to the selected servo drive and motor model. Please refer to Section 3.4, CN2 Connector.

Motor Model	Connector of Encoder Cable																		
ECMA-G△1303□S (300 W) ECMA-E△1305□S (500 W) ECMA-F11305□S (500 W) ECMA-G△1306□S (600 W) ECMA-F△1308□S (850 W) ECMA-G△1309□S (900 W) ECMA-C△1010□S (1000 W) ECMA-E△1310□S (1000 W) ECMA-F11313□S (1300 W) ECMA-E△1315□S (1500 W) ECMA-F11318□S (1800 W) ECMA-C△1020□S (2000 W) ECMA-E△1320□S (2000 W) ECMA-E△1820□S (2000 W) ECMA-C△1330□4 (3000 W) ECMA-E△1830□S (3000 W) ECMA-F△1830□S (3000 W) ECMA-E△1835□S (3500 W)	<p>3106A-20-29S Military Connector</p> <table border="1"> <thead> <tr> <th>Pin No.</th> <th>Terminal Symbol</th> <th>Wire Color</th> </tr> </thead> <tbody> <tr> <td>A</td> <td>T+</td> <td>Blue</td> </tr> <tr> <td>B</td> <td>T-</td> <td>Blue & Black</td> </tr> <tr> <td>S</td> <td>DC+5V</td> <td>Red / Red & White</td> </tr> <tr> <td>R</td> <td>GND</td> <td>Black / Black & White</td> </tr> <tr> <td>L</td> <td>BRAID SHIELD</td> <td>-</td> </tr> </tbody> </table>	Pin No.	Terminal Symbol	Wire Color	A	T+	Blue	B	T-	Blue & Black	S	DC+5V	Red / Red & White	R	GND	Black / Black & White	L	BRAID SHIELD	-
Pin No.	Terminal Symbol	Wire Color																	
A	T+	Blue																	
B	T-	Blue & Black																	
S	DC+5V	Red / Red & White																	
R	GND	Black / Black & White																	
L	BRAID SHIELD	-																	

Please select shielded multi-core and the shielded cable should connect to the SHIELD end. Please refer to the description of Section 3.1.6.

Note:

- 1) Box, (Δ) in servo motor model represents encoder type. $\Delta=1$: incremental, 20-bit; $\Delta=2$: incremental, 17-bit.
- 2) Box, (\square) in servo motor model represents brake or keyway / oil seal.

Specification and Definition of Motor Signal Cable

Motor Model	Color	Definition	AWG
ECML-S16□□□□□□S ECML-S20□□□□□□S ECML-S25□□□□□□S ECML-S32□□□□□□S	Black	Hall sensor 5V	26
	Black / Red	Hall sensor 0V	26
	White	U phase signal of hall sensor	26
	Brown	V phase signal of hall sensor	26
	Blue	W phase signal of hall sensor	26
	Orange	Temperature signal +	26
	Orange / Red	Temperature signal -	26

Note:

- 1) U, V, W are the bare wire, which has no connector and terminal.
- 2) The total length of standard cable is 500mm.
- 3) The cover of the green grounding cable is heat-shrink tubing. If users cut off the grounding cable and re-connect it, please connect it to the shielded net for better noise separation.
- 4) All signal cable of motor must connect to the servo drive.

3.1.6 Selection of Wire Rod

The recommended wire rods are shown as the following table.

Servo Drive and corresponding Motor Model		Power Wiring - Wire Diameter mm ² (AWG)			
		L1c, L2c	R, S, T	U, V, W	P ⁺ , C
ASD-A2R -0121-□	ECMA-C1040F□S	1.3 (AWG16)	2.1 (AWG14)	0.82 (AWG18)	2.1 (AWG14)
	ECMA-C△0401□S	1.3 (AWG16)	2.1 (AWG14)	0.82 (AWG18)	2.1 (AWG14)
ASD-A2R -0221-□	ECMA-C△0602□S	1.3 (AWG16)	2.1 (AWG14)	0.82 (AWG18)	2.1 (AWG14)
ASD-A2R -0421-□	ECMA-C△0604□S	1.3 (AWG16)	2.1 (AWG14)	0.82 (AWG18)	2.1 (AWG14)
	ECMA-C△0804□7	1.3 (AWG16)	2.1 (AWG14)	0.82 (AWG18)	2.1 (AWG14)
	ECMA-E△1305□S	1.3 (AWG16)	2.1 (AWG14)	0.82 (AWG18)	2.1 (AWG14)
	ECMA-G△1303□S	1.3 (AWG16)	2.1 (AWG14)	0.82 (AWG18)	2.1 (AWG14)
ASD-A2R -0721-□	ECMA-F11305□S	1.3 (AWG16)	2.1 (AWG14)	0.82 (AWG18)	2.1 (AWG14)
	ECMA-C△0807□S	1.3 (AWG16)	2.1 (AWG14)	0.82 (AWG18)	2.1 (AWG14)
	ECMA-C△0907□S	1.3 (AWG16)	2.1 (AWG14)	0.82 (AWG18)	2.1 (AWG14)
	ECMA-G△1306□S	1.3 (AWG16)	2.1 (AWG14)	0.82 (AWG18)	2.1 (AWG14)
ASD-A2R -1021-□	ECMA-C△0910□S	1.3 (AWG16)	2.1 (AWG14)	1.3 (AWG16)	2.1 (AWG14)
	ECMA-C△1010□S	1.3 (AWG16)	2.1 (AWG14)	1.3 (AWG16)	2.1 (AWG14)
	ECMA-E△1310□S	1.3 (AWG16)	2.1 (AWG14)	1.3 (AWG16)	2.1 (AWG14)
	ECMA-F△1308□S	1.3 (AWG16)	2.1 (AWG14)	1.3 (AWG16)	2.1 (AWG14)
	ECMA-G△1309□S	1.3 (AWG16)	2.1 (AWG14)	1.3 (AWG16)	2.1 (AWG14)
ASD-A2R-1521-□	ECMA-E△1315□S	1.3 (AWG16)	2.1 (AWG14)	1.3 (AWG16)	2.1 (AWG14)
ASD-A2R-2023-□	ECMA-C△1020□S	1.3 (AWG16)	2.1 (AWG14)	2.1 (AWG14)	2.1 (AWG14)
	ECMA-E△1320□S	1.3 (AWG16)	2.1 (AWG14)	2.1 (AWG14)	2.1 (AWG14)
	ECMA-E△1820□S	1.3 (AWG16)	2.1 (AWG14)	3.3 (AWG12)	2.1 (AWG14)
	ECMA-F11313□S	1.3 (AWG16)	2.1 (AWG14)	3.3 (AWG12)	2.1 (AWG14)
	ECMA-F11318□S	1.3 (AWG16)	2.1 (AWG14)	3.3 (AWG12)	2.1 (AWG14)
ASD-A2R-3023-□	ECMA-C△1330□4	1.3 (AWG16)	2.1 (AWG14)	3.3 (AWG12)	2.1 (AWG14)
	ECMA-E△1830□S	1.3 (AWG16)	2.1 (AWG14)	3.3 (AWG12)	2.1 (AWG14)
	ECMA-E△1835□S	1.3 (AWG16)	2.1 (AWG14)	3.3 (AWG12)	2.1 (AWG14)
	ECMA-F△1830□S	1.3 (AWG16)	2.1 (AWG14)	3.3 (AWG12)	2.1 (AWG14)

Servo Drive Model	Encoder Wiring — Wire Diameter mm ² (AWG)			
	Size	Number	Specification	Standard Length
ASD-A2R-0121-□	0.13 (AWG26)	10 cores (4 pairs)	UL2464	3 mm (9.84 inches)
ASD-A2R-0221-□	0.13 (AWG26)	10 cores (4 pairs)	UL2464	3 mm (9.84 inches)
ASD-A2R-0421-□	0.13 (AWG26)	10 cores (4 pairs)	UL2464	3 mm (9.84 inches)
ASD-A2R-0721-□	0.13 (AWG26)	10 cores (4 pairs)	UL2464	3 mm (9.84 inches)
ASD-A2R-1021-□	0.13 (AWG26)	10 cores (4 pairs)	UL2464	3 mm (9.84 inches)
ASD-A2R-1521-□	0.13 (AWG26)	10 cores (4 pairs)	UL2464	3 mm (9.84 inches)
ASD-A2R-2023-□	0.13 (AWG26)	10 cores (4 pairs)	UL2464	3 mm (9.84 inches)
ASD-A2R-3023-□	0.13 (AWG26)	10 cores (4 pairs)	UL2464	3 mm (9.84 inches)

Note:

- 1) Please use shielded twisted-pair cable for encoder wiring so as to reduce the interference of the noise.
- 2) The shield should connect to the ⊕ phase of SHIELD.
- 3) Please follow the Selection of Wire Rod when wiring in order to avoid the danger it may occur.
- 4) Box, (□) at the end of the servo drive model represents the model code of ASDA-A2R. Please refer to the model information of the product you purchased.
- 5) Box, (□) in servo motor model represents brake or keyway / oil seal.

3.2 Schematic Diagram of Servo System

■ 220 V 400 W (included) model below (No built-in regenerative resistor)

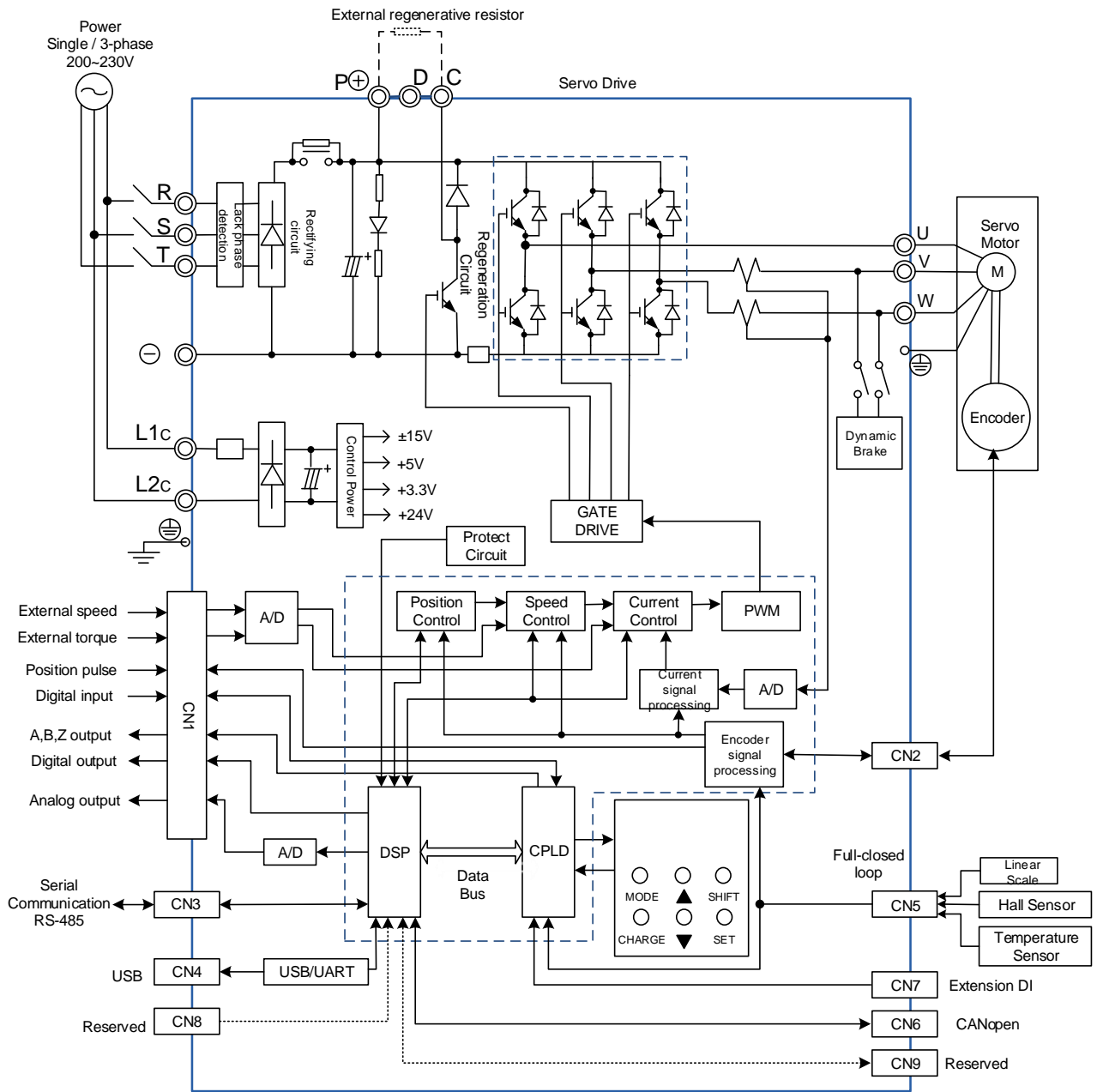

■ 220 V 750 W ~ 3 kW Model (Built-in Regenerative Resistor and Fan)

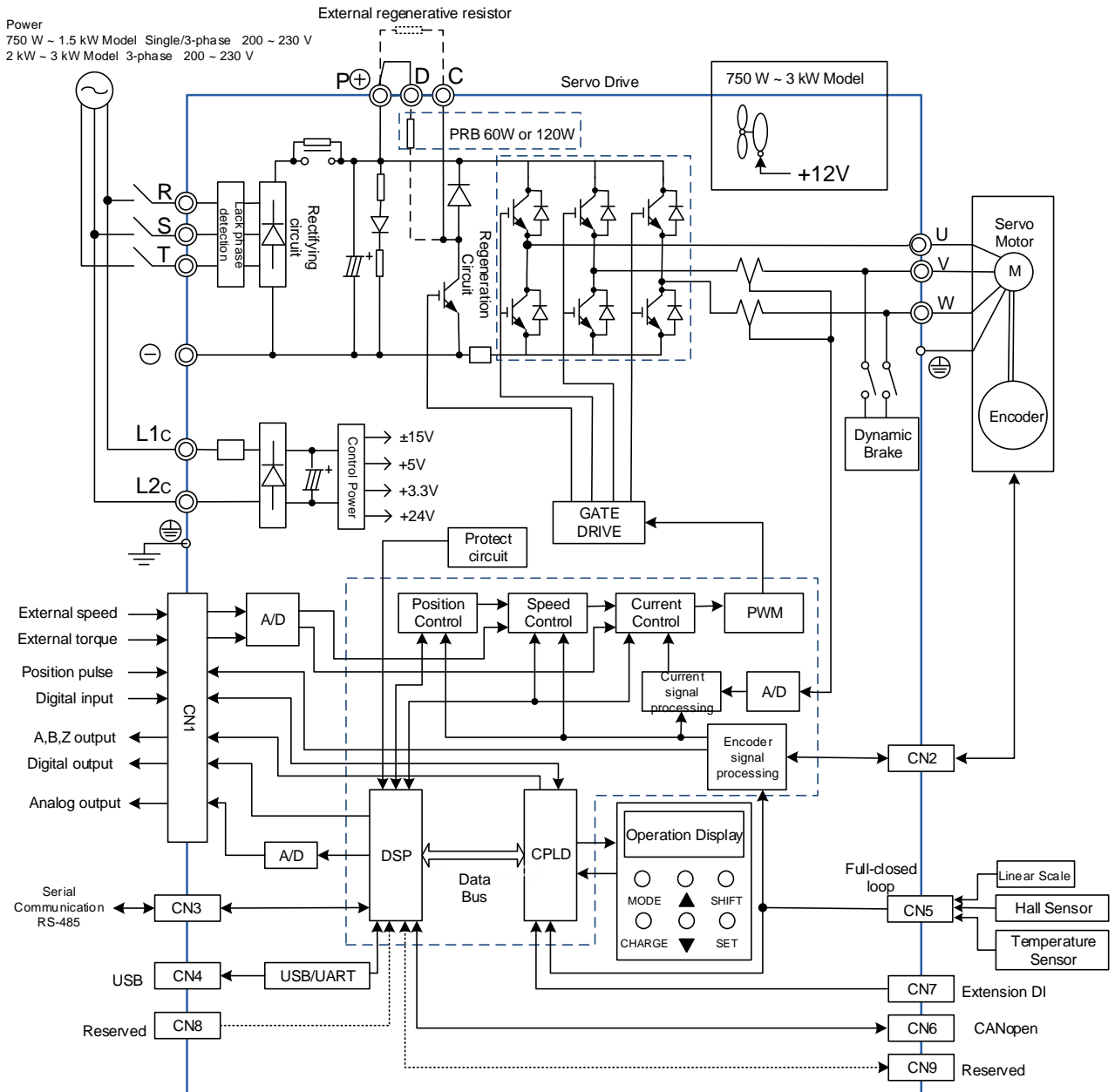

3.3 I/O Signal (CN1) Connection

3.3.1 I/O Signal (CN1) Connector Terminal Layout

In order to have a more flexible communication with the master, 5 programmable Digital Outputs (DO) and 8 programmable Digital Inputs (DI) are provided. The setting of 8 digital inputs and 5 digital outputs of each axis are parameter P2-10~P2-17 and parameter P2-18~P2-22 respectively. In addition, the differential output encoder signal, A+, A-, B+, B-, Z+ and Z-, input of analog torque command, analog speed/position command and pulse position command are also provided. The followings are the pin diagrams.

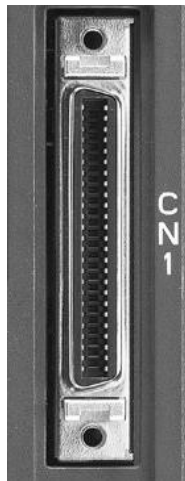

CN1 Connector (female)

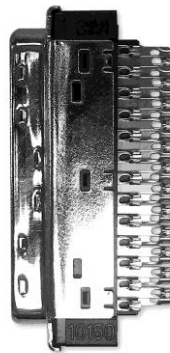

Side view



Rear view

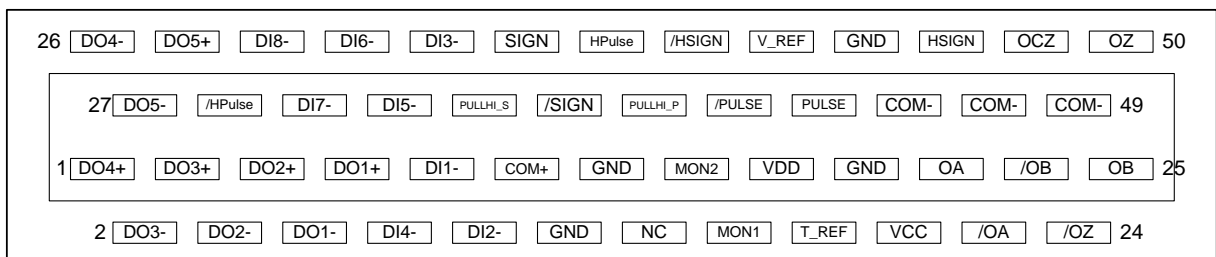

The rear wiring terminal of CN1 connector

2	DO3-	Digital output	1	DO4+	Digital output	27	DO5-	Digital output	26	DO4-	Digital output
			3	DO3+	Digital output			High-speed position command pulse (-)	28	DO5+	Digital output
4	DO2-	Digital output	5	DO2+	Digital output	29	/HPULSE		30	DI8-	Digital input
6	DO1-	Digital output	7	DO1+	Digital output	31	DI7-	Digital input	32	DI6-	Digital input
8	DI4-	Digital input	9	DI1-	Digital input	33	DI5-	Digital input	34	DI3-	Digital input
10	DI2-	Digital input	11	COM+	Power input (12~24V)	35	PULL HI_S (Sign)	Pull-high voltage of sign	36	SIGN	Position command signal (-)
12	GND	Analog input signal ground	13	GND	Analog input signal ground	37	/SIGN	Position command signal (-)	38	HPULSE	High-speed position command pulse (+)
14	NC	No connection	15	MON2	Analog monitor output 2	39	PULL HI_P (Pulse)	Pull-high voltage of pulse	40	/HSIGN	High-speed position command (-)
16	MON1	Analog monitor output 1	17	VDD	+24V power output (for external I/O)	41	/PULSE	Position command pulse (-)	42	V_REF	Speed analog command input (+)
18	T_REF	Torque analog command input	19	GND	Analog input signal ground	43	PULSE	Position command pulse (+)	44	GND	Analog input signal ground
20	VCC	+12V power output (for analog command)	21	OA	Encoder / A pulse output	45	COM-	VDD (24V) power ground	46	HSIGN	High-speed position command (+)
22	/OA	Encoder / A pulse output	23	/OB	Encoder / B pulse output	47	COM-	VDD(24V) power ground	48	OCZ	Encoder Z pulse open-collector output
24	/OZ	Encoder / Z pulse output	25	OB	Encoder / B pulse output	49	COM-	VDD(24V) power ground	50	OZ	Encoder Z pulse differential output

Note: NC means NO CONNECTION. This terminal is for internal use only. Do not connect it, or it may damage the servo drive.

3.3.2 Explanation of I/O (CN1) Connector Signal

The following details the signals listed in previous section:

General Signals

Signal Name		Pin No	Function	Wiring Method (Refer to 3.4.3)
Analog Command (input)	V_REF	42	(1) The speed command of the motor is -10 V ~ +10 V which means the speed command is -3000 ~ +3000 r/min (default). It can change the corresponding range via parameters. (2) The position command of the motor is -10 V ~ +10 V which means the position command is -3 cycles ~ +3 cycles (default).	C1
	T_REF	18	The torque command of the motor is -10 V ~ +10 V which means the rated torque command of -100 % ~ +100 %.	C1
Analog Monitor (output)	MON1 MON2	16 15	The operating state of the motor can be shown by analog voltage, such as speed and current. This drive provides two channel outputs. Users can select the desired monitoring data via parameter P0-03. This signal is based on the power ground.	C2
Position Pulse (input)	PULSE /PULSE SIGN /SIGN PULL HI_P PULL HI_S	43 41 36 37 39 35	Position pulse can be inputted by Line Driver (single phase max. frequency 500KHz) or open-collector (single phase max. frequency 200 KHz). Three kinds of command type can be selected via P1-00, CW pulse + CCW pulse, pulse + direction, A pulse + B pulse. When position pulse uses open-collector, the terminal should be connected to an external applied power in order to pull high.	C3/C4
High-speed position pulse (input)	HPULSE /HPULSE E HSIGN /HSIGN	38 29 46 40	High-speed position pulse only accepts Line Drive (+5 V) as the input type. The max. frequency of single phase is 4MHz. There are three kinds of command types, A pulse + B pulse, CW pulse + CCW pulse and pulse + direction. Please refer to parameter P1-00.	C4-2
Position pulse (output)	OA /OA	21 22	Encoder signal output A, B, Z (Line Drive output)	C13/C14
	OB /OB	25 23		
	OZ /OZ	50 24		
	OCZ	48	Encoder signal output Z (Open-collector output)	-

Signal Name		Pin No	Function	Wiring Method (Refer to 3.4.3)
Power	VDD	17	VDD is the +24 V power provided by the drive and is for Digital Input (DI) and Digital Output (DO) signal. The maximum current is 500 mA.	-
	COM+ COM-	11 45 47 49	COM+ is the common input of Digital Input (DI) and Digital Output (DO) voltage. When using VDD, VDD should be connected to COM+. If not using, it needs to apply the external power (+12 V ~ + 24 V). Its positive end should connect to COM+ and the negative end should connect to COM-.	
	VCC	20	VCC is the +12V power provided by the drive. It is used for providing the simple analog command (speed or torque command). The maximum current is 100 mA.	
	GND	12,13, 19,44	VCC voltage is based on GND.	
Other	NC	14	NO CONNECTION. This terminal is for internal use only. Do not connect it, or it may damage the servo drive.	

There are numerous operation mode of this servo drive (please refer to Chapter 6.1). Each operation mode needs different I/O signal. In order to use the terminal in a more efficient way, the selection of I/O signal has to be programmable. That is to say, users can choose the desired DI/DO signal to meet the demand. Basically, the default setting of DI/DO signal has already have the appropriate function which can satisfy the demand of normal application.

Users have to select the operation mode based on the needs first (please refer to Chapter 6.1 for the introduction of each mode) and refer to the following DI/DO table to know the corresponding default setting of DI/DO signal and Pin No of the selected mode in order to conduct the wiring.

The table below lists the default setting of DI/DO signal function and pin No:

The explanation of DO signal default setting is as the followings.

DO Signal Name	Operation Mode	Pin No		Function	Wiring Method (Refer to 3.4.3)
		+	-		
SRDY	ALL	7	6	When the servo drive applies to the power and no alarm (ALRM) occurs in control circuit and motor power circuit, this DO is ON.	C5/C6/ C7/C8
SON	N/A	-	-	When the DI.SON is ON and the motor servo circuit can operate smoothly, this DO is ON.	
ZSPD	ALL	5	4	When the motor speed is slower than the setting value of parameter P1-38, this DO is ON.	
TSPD	ALL (except PT, PR)	-	-	When the motor actual speed (r/min) is faster than the setting value of parameter P1-39, this DO is ON.	
TPOS	PT, PR, PT-S, PT-T, PR-S, PR-T	1	26	When the deviation between the motor command and actual position (PULSE) is smaller than the setting value of parameter P1-54, this DO is ON.	C5/C6/ C7/C8
TQL	N/A	-	-	When torque is limiting, this DO is ON.	
ALRM	ALL	28	27	When the alarm occurs (except forward/reverse limit, emergency stop, communication error, under voltage), this DO is ON.	
BRKR	ALL	-	-	Control contact of brake.	
HOME	ALL	3	2	When homing is completed, this DO is ON.	
OLW	ALL	-	-	When the overload level is reached, this DO is ON.	
WARN	ALL	-	-	A warning occurs. When it is in the status of forward/reverse limit, emergency stop, communication error, under voltage, this DO is ON.	
OVF	ALL	-	-	Position command overflows	
SNL(SCWL)	PR	-	-	Reverse software limit	
SPL(SCCWL)	PR	-	-	Forward software limit	
Cmd_OK	PR	-	-	The output of internal position command is completed.	
CAP_OK	PR	-	-	CAPTURE procedure is completed.	
MC_OK	PR	-	-	When DO.Cmd_OK and TPOS are ON, this DO is ON.	
CAM_AREA	PR	-	-	The master position of E-CAM is inside the setting area.	
S_CMP	S, Sz	-	-	When the deviation between the speed command and the feedback speed of the motor is smaller than the setting value of parameter P1-47, this DO is ON.	
SDO_0	ALL	-	-	Output the status of bit00 of P4-06	
SDO_1	ALL	-	-	Output the status of bit01 of P4-06	

DO Signal Name	Operation Mode	Pin No		Function	Wiring Method (Refer to 3.4.3)
		+	-		
SDO_2	ALL	-	-	Output the status of bit02 of P4-06	
SDO_3	ALL	-	-	Output the status of bit03 of P4-06	
SDO_4	ALL	-	-	Output the status of bit04 of P4-06	
SDO_5	ALL	-	-	Output the status of bit05 of P4-06	
SDO_6	ALL	-	-	Output the status of bit06 of P4-06	
SDO_7	ALL	-	-	Output the status of bit07 of P4-06	
SDO_8	ALL	-	-	Output the status of bit08 of P4-06	
SDO_9	ALL	-	-	Output the status of bit09 of P4-06	
SDO_A	ALL	-	-	Output the status of bit10 of P4-06	
SDO_B	ALL	-	-	Output the status of bit11 of P4-06	
SDO_C	ALL	-	-	Output the status of bit12 of P4-06	
SDO_D	ALL	-	-	Output the status of bit13 of P4-06	
SDO_E	ALL	-	-	Output the status of bit14 of P4-06	
SDO_F	ALL	-	-	Output the status of bit15 of P4-06	

Note:

- 1) For example, if the user selects PR mode, pin 3 and 2 are HOME. If the user selects S mode, pin 3 and 2 are TSPD.
- 2) The unlisted Pin No means the signal is not the preset one. If users want to use it, parameters need to be changed and set as the desired ones. Please refer to Section 3.4.4 for further details.

The explanation of DI signal default setting is as the followings

DI Signal Name	Operation Mode	Pin No	Function	Wiring Method (Refer to 3.4.3)																																																																								
SON	ALL	9	When DI is ON, the servo circuit will be activated and the motor coil will generate current.	C9/C10 C11/C12																																																																								
ARST	ALL	33	When the alarm (ALRM) occurs, this signal is used to reset the servo drive and output the signal, Ready (SRDY) again.																																																																									
GAINUP	ALL	-	It is for switching the controller gain.																																																																									
CCLR	PT, PR	10	It is for clearing the deviation counter.																																																																									
ZCLAMP	ALL	-	When this DI is ON and the motor speed is slower than the setting of P1-38, the motor position will be locked when the signal is triggered.																																																																									
CMDINV	PR, T, S	-	When this DI is ON, the motor will operate in the opposite direction.																																																																									
CTRG	PR, PR-S, PR-T	10	In PR mode, the moment CTRG is ON (rising edge), save the position command selected by POS0~2 into the controller and then trigger the command.																																																																									
TRQLM	S, Sz	10	ON means the torque limit command is effective.																																																																									
SPDLM	T, Tz	10	ON means the speed limit command is effective.																																																																									
POS0	P, PR-S, PR-T	34	In PR mode, the source of position command:																																																																									
POS1		8	<table border="1"> <thead> <tr> <th>Position Command</th> <th>POS5</th> <th>POS4</th> <th>POS3</th> <th>POS2</th> <th>POS1</th> <th>POS0</th> <th>CTRG</th> <th>Corresponding parameter</th> </tr> </thead> <tbody> <tr> <td>P1</td> <td>0</td> <td>0</td> <td>0</td> <td>0</td> <td>0</td> <td>0</td> <td>↑</td> <td>P6-00 P6-01</td> </tr> <tr> <td>P2</td> <td>0</td> <td>0</td> <td>0</td> <td>0</td> <td>0</td> <td>1</td> <td>↑</td> <td>P6-02 P6-03</td> </tr> <tr> <td>~</td> <td></td> <td></td> <td></td> <td></td> <td></td> <td></td> <td></td> <td>~</td> </tr> <tr> <td>P50</td> <td>1</td> <td>1</td> <td>0</td> <td>0</td> <td>1</td> <td>0</td> <td>↑</td> <td>P6-98 P6-99</td> </tr> <tr> <td>P51</td> <td>1</td> <td>1</td> <td>0</td> <td>0</td> <td>1</td> <td>1</td> <td>↑</td> <td>P7-00 P7-01</td> </tr> <tr> <td>~</td> <td></td> <td></td> <td></td> <td></td> <td></td> <td></td> <td></td> <td>~</td> </tr> <tr> <td>P64</td> <td>1</td> <td>1</td> <td>1</td> <td>1</td> <td>1</td> <td>1</td> <td>↑</td> <td>P7-26 P7-27</td> </tr> </tbody> </table>		Position Command	POS5	POS4	POS3	POS2	POS1	POS0	CTRG	Corresponding parameter	P1	0	0	0	0	0	0	↑	P6-00 P6-01	P2	0	0	0	0	0	1	↑	P6-02 P6-03	~								~	P50	1	1	0	0	1	0	↑	P6-98 P6-99	P51	1	1	0	0	1	1	↑	P7-00 P7-01	~								~	P64	1	1	1	1	1	1	↑	P7-26 P7-27
Position Command		POS5	POS4		POS3	POS2	POS1	POS0	CTRG	Corresponding parameter																																																																		
P1		0	0		0	0	0	0	↑	P6-00 P6-01																																																																		
P2		0	0		0	0	0	1	↑	P6-02 P6-03																																																																		
~										~																																																																		
P50		1	1		0	0	1	0	↑	P6-98 P6-99																																																																		
P51		1	1		0	0	1	1	↑	P7-00 P7-01																																																																		
~									~																																																																			
P64	1	1	1	1	1	1	↑	P7-26 P7-27																																																																				
POS2	-																																																																											
POS3	-																																																																											
POS4	-																																																																											
POS5	-																																																																											
STOP	-	-	Stop																																																																									
SPD0	S, Sz, PT-S, PR-S, S-T	34	The source of selecting speed command:																																																																									
SPD1		8	<table border="1"> <thead> <tr> <th>SPD1</th> <th>SPD0</th> <th>Command Source</th> </tr> </thead> <tbody> <tr> <td>0</td> <td>0</td> <td>S mode is analog input while Sz mode is 0.</td> </tr> <tr> <td>0</td> <td>1</td> <td>P1-09</td> </tr> <tr> <td>1</td> <td>0</td> <td>P1-10</td> </tr> <tr> <td>1</td> <td>1</td> <td>P1-11</td> </tr> </tbody> </table>	SPD1	SPD0	Command Source	0	0	S mode is analog input while Sz mode is 0.	0	1	P1-09	1	0	P1-10	1	1	P1-11																																																										
		SPD1	SPD0	Command Source																																																																								
		0	0	S mode is analog input while Sz mode is 0.																																																																								
0	1	P1-09																																																																										
1	0	P1-10																																																																										
1	1	P1-11																																																																										

DI Signal Name	Operation Mode	Pin No	Function	Wiring Method (Refer to 3.4.3)		
TCM0	PT,T, PT-T	Tz, 34	The source of selecting torque command:		C9/C10 C11/C12	
			TCM1	TCM0		Command Source
TCM1	PR-T, S-T	8	0	0		T mode is analog input while Tz mode is 0.
			0	1		P1-12
			1	0		P1-13
			1	1		P1-14
S-P	PT-S, PR-S	31	Mode switching. OFF: Speed; ON: Position			
S-T	S-T	31	Mode switching. OFF: Speed; ON: Torque			
T-P	PT-T, PR-T	31	Mode switching. OFF: Torque; ON: Position			
PT-PR	PT,PR	-	When selecting PT-PR mode or the multi-mode, PT-PR-S, users can select the source via this DI. When this DI is OFF, it is in PT mode. When this DI is ON, it is in PR mode.			
PTAS	-	-	In position PT mode, when the DI is OFF, the external command source is external pulse. When the signal is ON, then the source is external analog voltage.			
PTCMS	-	-	In position PT mode, when the DI is OFF, the source of external command pulse is low-speed pulse (PULSE, /PULSE, SIGN, /SIGN Pin). When the DI is ON, the source will be high-speed pulse. This function can go with handwheel. This DI can be used to switch the source of command pulse.			
EMGS	ALL	30	It is contact B and has to be ON frequently; otherwise the alarm (ALRM) will occur.			
NL (CWL)	PT, PR, S, T Sz, Tz	32	Reverse inhibit limit (contact B) and has to be ON frequently; or the alarm (ALRM) will occur.			
PL (CCWL)	PT, PR, S, T Sz, Tz	31	Forward inhibit limit (contact B) and has to be ON frequently; or the alarm (ALRM) will occur.			
ORGP	PR	-	When DI is ON, the drive will start homing.			
SHOM	PR	-	In PR mode, it needs to search the origin. When this DI is ON, the origin searching function is activated. (Please refer to the setting of parameter P1-47.)			
CAM	PR	-	E-cam engaging control (please refer to the setting of value U and Z of P5-88.)			
JOGU	ALL	-	When this DI is ON, the motor JOG operates in forward direction.			
JOGD	ALL	-	When this DI is ON, the motor JOG operates in reverse direction.			
EV1	PR	-	Event trigger PR command			
EV2	PR	-	Event trigger PR command			
GNUM0	PT, PR, PT-S, PR-S	-	Electronic gear ratio (numerator) selection 0 (Please refer to P2-60~P2-62 for gear ratio selection (numerator).)		C9/C10 C11/C12	
GNUM1	PT, PR, PT-S, PR-S	-	Electronic gear ratio (numerator) selection 1 (Please refer to P2-60~P2-62 for gear ratio selection (numerator).)			
INHP	PT, PT-S	-	In position mode, when this DI is ON, the external pulse input command is not working.			

The default setting of DI and DO in each operation mode is shown as the followings. Please note that the following table neither detail the information as the previous one nor show the Pin number of each signal. However, each operation mode is separated in different columns in order to avoid the confusion.

Table 3.1 Default Value of DI Input Function

Symbol	DI Code	Input Function	PT	PR	S	T	Sz	Tz	PT S	PT T	PR S	PR T	S T
SON	0x01	Servo On	DI1	DI1	DI1	DI1	DI1	DI1	DI1	DI1	DI1	DI1	DI1
ARST	0x02	Alarm reset	DI5	DI5	DI5	DI5	DI5	DI5					
GAINUP	0x03	Gain switch											
CCLR	0x04	Pulse clear	DI2						DI2	DI2			
ZCLAMP	0x05	Zero speed clamp											
CMDINV	0x06	The input command will be in reverse direction.											
Reserved	0x07	Reserved											
CTRG	0x08	Internal position command triggered		DI2							DI2	DI2	
TRQLM	0x09	Torque limit			DI2		DI2						
SPDLM	0x10	Speed limit				DI2		DI2					
POS0	0x11	Internal position command selection 0		DI3							DI3	DI3	
POS1	0x12	Internal position command selection 1		DI4							DI4	DI4	
POS2	0x13	Internal position command selection 2											
POS3	0x1A	Internal position command selection 3											
POS4	0x1B	Internal position command selection 4											
POS5	0x1C	Internal position command selection 5											
STOP	0x46	Motor stops											
SPD0	0x14	Speed command selection 0			DI3		DI3		DI3		DI5		DI3
SPD1	0x15	Speed command selection 1			DI4		DI4		DI4		DI6		DI4
TCM0	0x16	Torque command selection 0	DI3			DI3		DI3		DI3		DI5	DI5
TCM1	0x17	Torque command selection 1	DI4			DI4		DI4		DI4		DI6	DI6
S-P	0x18	Mode switch between speed and position command							DI7		DI7		
S-T	0x19	Mode switch between speed and torque command											DI7
T-P	0x20	Mode switch								DI7		DI7	

Symbol	DI Code	Input Function	PT	PR	S	T	Sz	Tz	PT S	PT T	PR S	PR T	S T
		between torque and position command											
PT-PR	0x2B	Switch between PT and PR command											
PTAS	0x2C	In PT mode, the switch between command pulse and analog											
PTCMS	0x2D	In PT mode, the switch between low-speed and high-speed command											
EMGS	0x21	Emergency stop	DI8	DI8	DI8	DI8	DI8	DI8	DI8	DI8	DI8	DI8	DI8
NL(CWL)	0x22	Reverse inhibit limit	DI6	DI6	DI6	DI6	DI6	DI6					
PL(CCWL)	0x23	Forward inhibit limit	DI7	DI7	DI7	DI7	DI7	DI7					
ORGP	0x24	Original point of homing											
SHOM	0x27	Homing is activated											
CAM	0x36	E-Cam engaged											
JOGU	0x37	Forward JOG input											
JOGD	0x38	Reverse JOG input											
EV1	0x39	Event trigger PR command #1 (refer to the setting of P5-98, P5-99)											
EV2	0x3A	Event trigger PR command #2 (refer to the setting of P5-98, P5-99)											
EV3	0x3B	Event trigger PR command #3 firmware V1.008 sub04 will be provided afterwards)											
EV4	0x3C	Event trigger PR command #4 (firmware V1.008 sub04 will be provided afterwards)											
GNUM0	0x43	Electronic gear ratio (numerator) selection 0											
GNUM1	0x44	Electronic gear ratio (numerator) selection 1											
INHP	0x45	Pulse input inhibit											

Note: please refer to Section 3.4.1 for corresponding pin from DI1 ~ 8.

Table 3.2 Default Value of DO Output Function

Symbol	DO Code	Output Function	PT	PR	S	T	Sz	Tz	PT S	PT T	PR S	PR T	S T
SRDY	0x01	Servo is ready	DO1	DO1	DO1	DO1	DO1	DO1	DO1	DO1	DO1	DO1	DO1
SON	0x02	Servo is On.											
ZSPD	0x03	Zero-speed reached	DO2	DO2	DO2	DO2	DO2	DO2	DO2	DO2	DO2	DO2	DO2
TSPD	0x04	Reach the target speed			DO3	DO3	DO3	DO3	DO3	DO3	DO3	DO3	DO3
TPOS	0x05	Reach the target position	DO4	DO4					DO4	DO4	DO4	DO4	
TQL	0x06	Torque limit											
ALRM	0x07	Servo alarm	DO5	DO5	DO5	DO5	DO5	DO5	DO5	DO5	DO5	DO5	DO5
BRKR	0x08	Brake			DO4	DO4	DO4	DO4					
HOME	0x09	Homing complete	DO3	DO3									
OLW	0x10	Early warning for overload											
WARN	0x11	Servo warning											
OVF	0x12	Position command overflows											
SNL(SCWL)	0x13	Reverse software limit											
SPL(SCCWL)	0x14	Forward software limit											
Cmd_OK	0x15	Internal position command is completed											
CAP_OK	0x16	Capture procedure is completed											
MC_OK	0x17	Servo procedure is completed											
CAM_AREA	0x18	Master position area of E-CAM											
SP_OK	0x19	Target speed reached											
SDO_0	0x30	Output the status of bit00 of P4-06											
SDO_1	0x31	Output the status of bit01 of P4-06											
SDO_2	0x32	Output the status of bit02 of P4-06											
SDO_3	0x33	Output the status of bit03 of P4-06											
SDO_4	0x34	Output the status of bit04 of P4-06											
SDO_5	0x35	Output the status of bit05 of P4-06											
SDO_6	0x36	Output the status of bit06 of P4-06											
SDO_7	0x37	Output the status of bit07 of P4-06											
SDO_8	0x38	Output the status of bit08 of P4-06											

Symbol	DO Code	Output Function	PT	PR	S	T	Sz	Tz	PT S	PT T	PR S	PR T	S T
SDO_9	0x39	Output the status of bit09 of P4-06											
SDO_A	0x3A	Output the status of bit10 of P4-06											
SDO_B	0x3B	Output the status of bit11 of P4-06											
SDO_C	0x3C	Output the status of bit12 of P4-06											
SDO_D	0x3D	Output the status of bit13 of P4-06											
SDO_E	0x3E	Output the status of bit14 of P4-06											
SDO_F	0x3F	Output the status of bit15 of P4-06											

Note: please refer to Section 3.4.1 for corresponding pin from DO1 to 5.

3.3.3 Wiring Diagram (CN1)

The valid voltage of speed analog command and torque analog command is between -10V and +10V. The command value can be set via relevant parameters. The input impedance is 10K Ω .

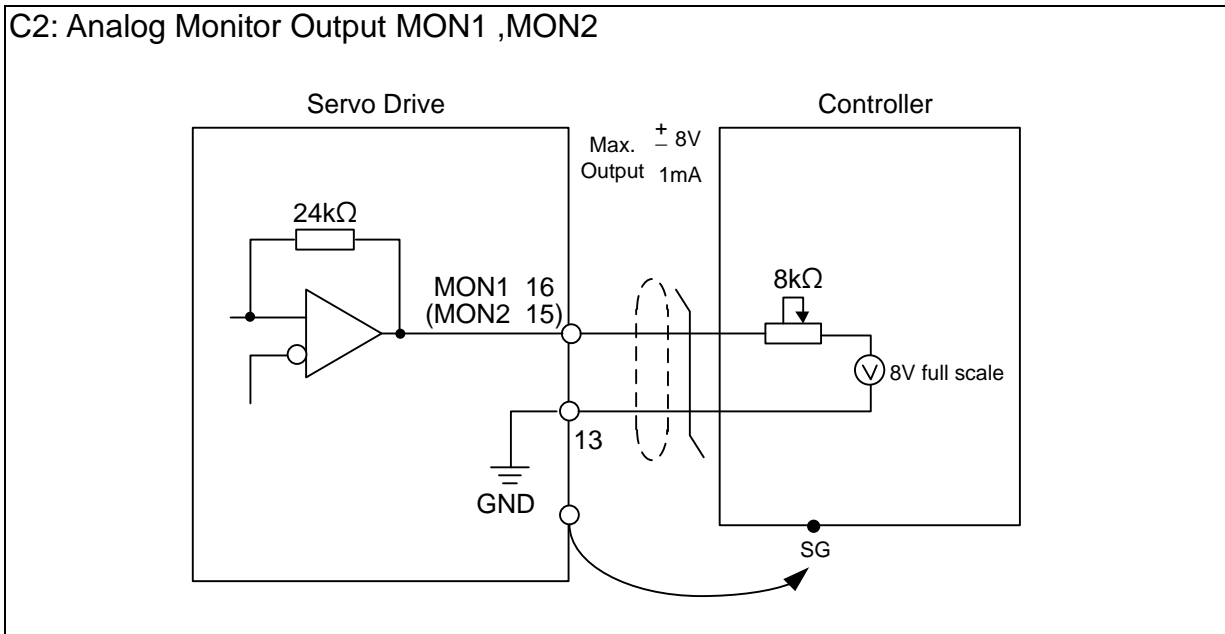
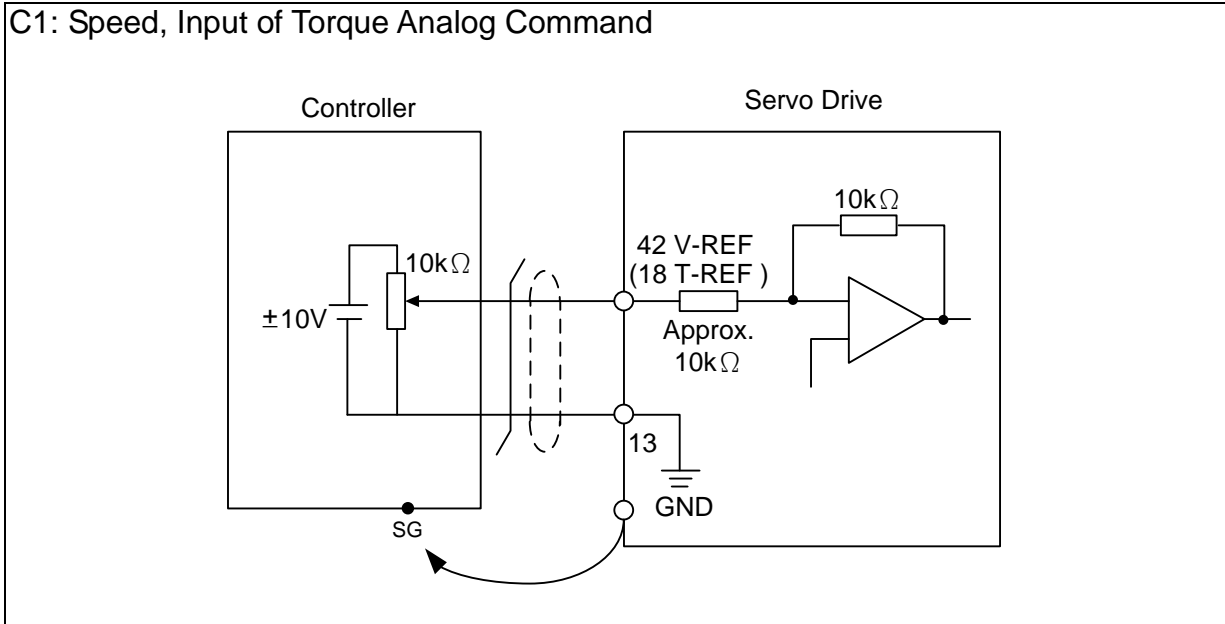

Pulse command can be input by the way of open-collector or Line driver. The maximum input pulse of Line driver is 500 kpps and 200 kpps for open-collector.

C3-1: The source of pulse input is open-collector NPN equipment which applies the internal power of the servo drive.

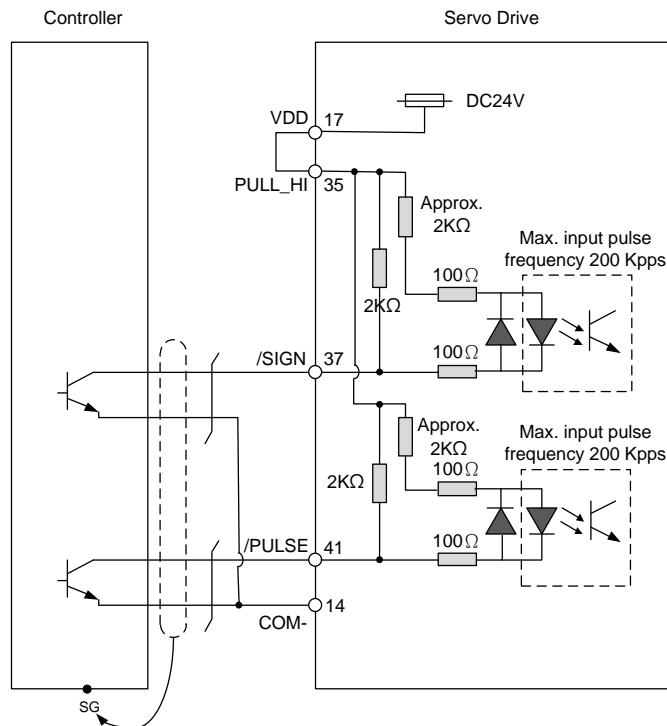

C3-2: The source of pulse input is open-collector PNP equipment which applies the internal power of the servo drive.

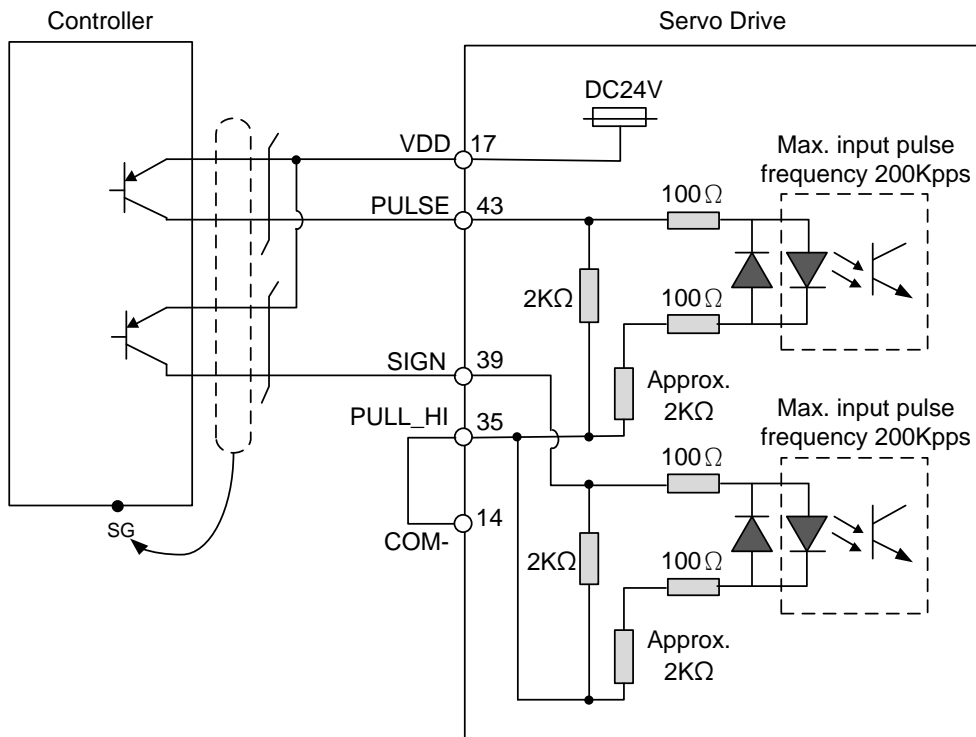

➤ **Caution: Do not apply to dual power or it may damage the servo drive.**

C3-3: The source of pulse input is open-collector NPN equipment and applies the external power.

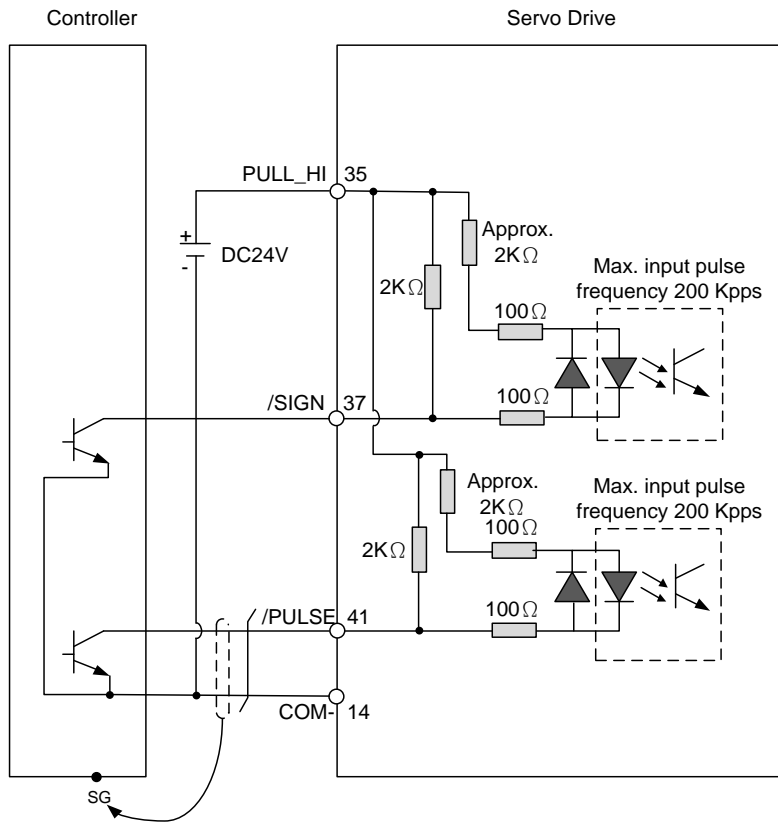

C3-4: The source of pulse input is open-collector PNP equipment and applies the external power.

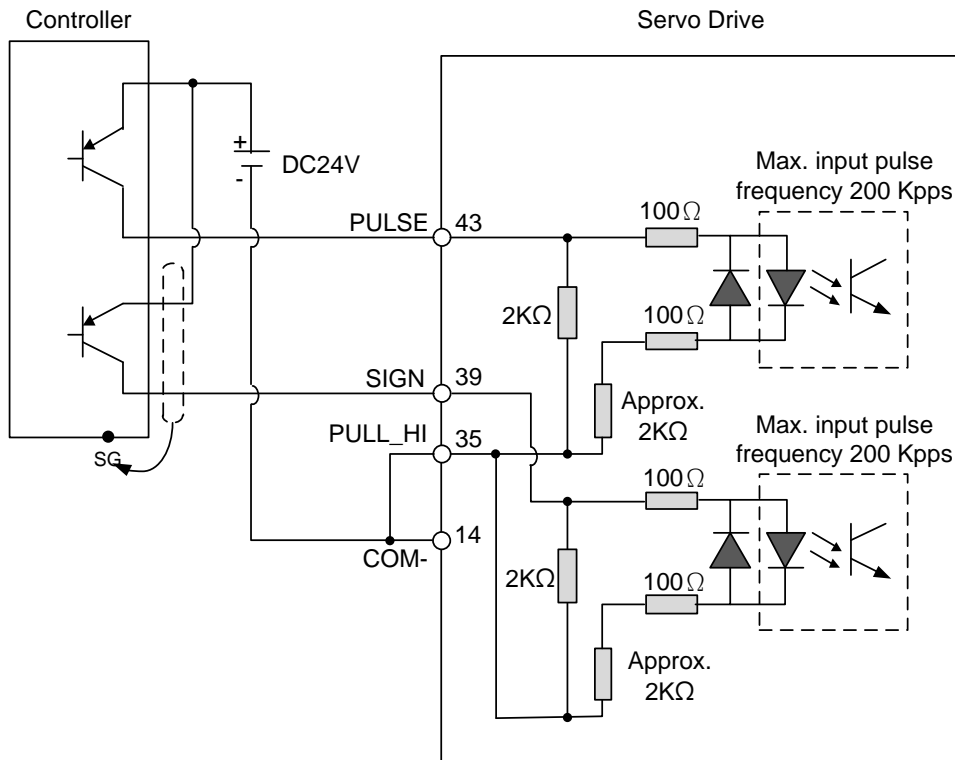

➤ **Caution: Do not apply to dual power or it may damage the servo drive.**

C4-1: Pulse input (Line driver) can only apply to 5V power. Do not apply to 24V power.

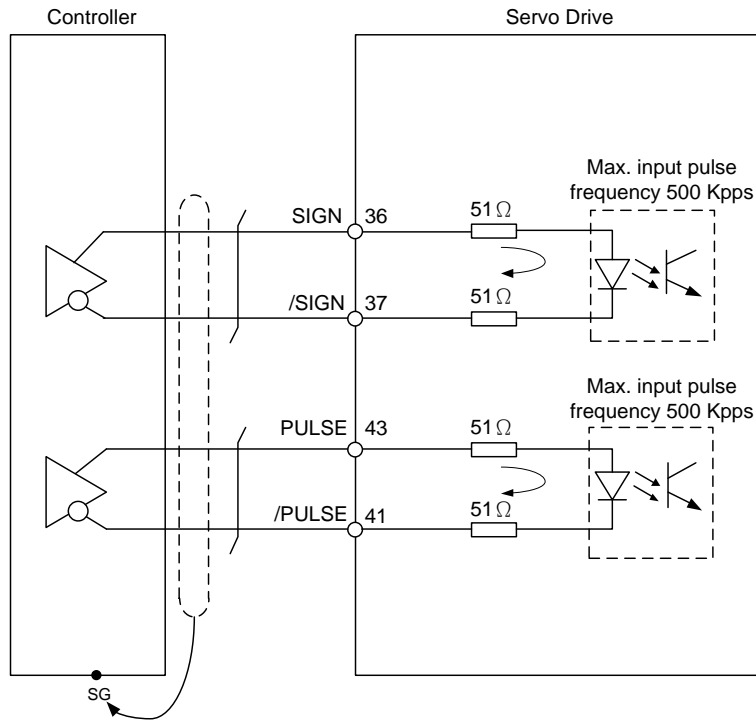

➤ **This opto-isolator is one-way input, please be ensured the direction of current of pulse input is correct.**

C4-2: High-speed pulse input (Line driver) can only apply to 5V power. Do not apply to 24V power.

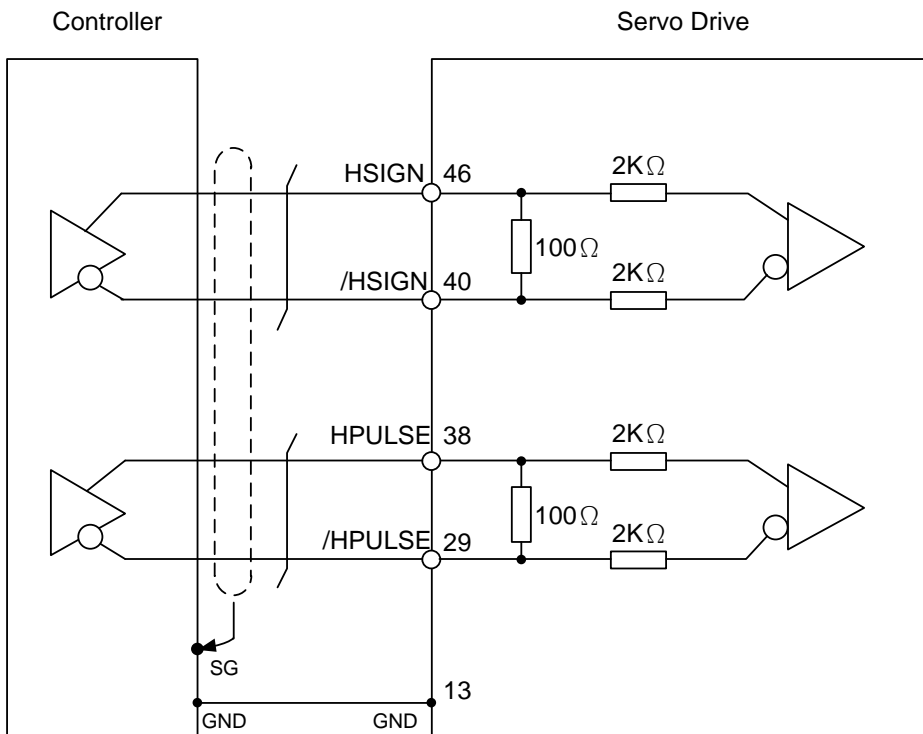

➤ **The high-speed pulse input interface of the servo drive is not the isolated interface. In order to reduce the interference of the noise, it is suggested that the terminal ground of the controller and the servo drive should be connected to each other.**

When the drive connects to inductive load, the diode has to be installed. (The permissible current is under 40mA. The surge current is under 100mA.)

C5: Wiring of DO signal. The servo drive applies to the internal power and the resistor is general load.

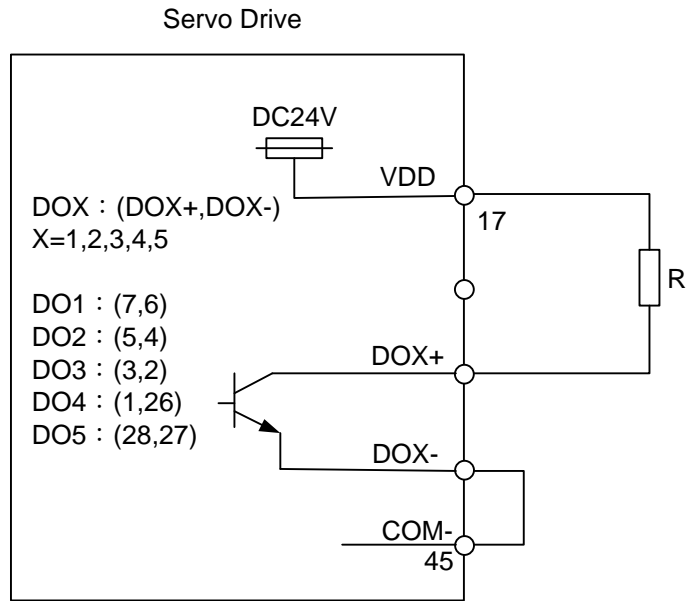

C6: Wiring of DO signal. The servo drive applies to the internal power and the resistor is inductive load.

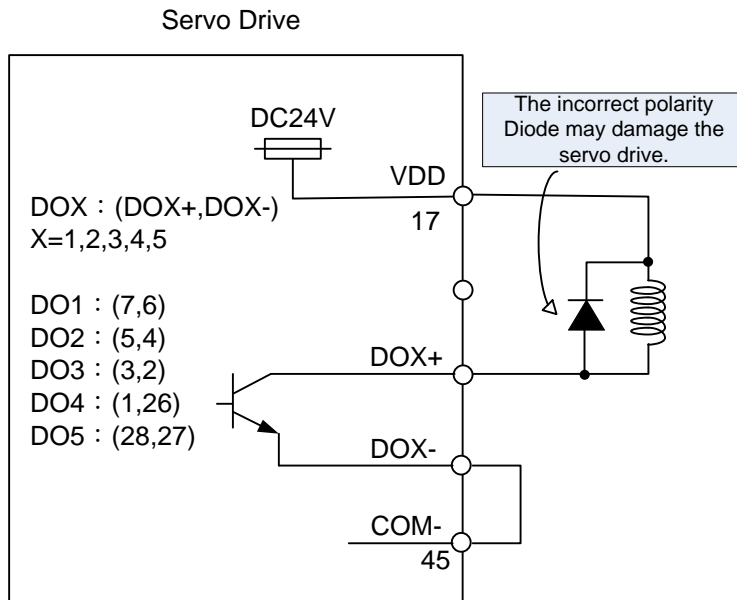

C7: Wiring of DO signal. The servo drive applies to the external power and the resistor is general load.

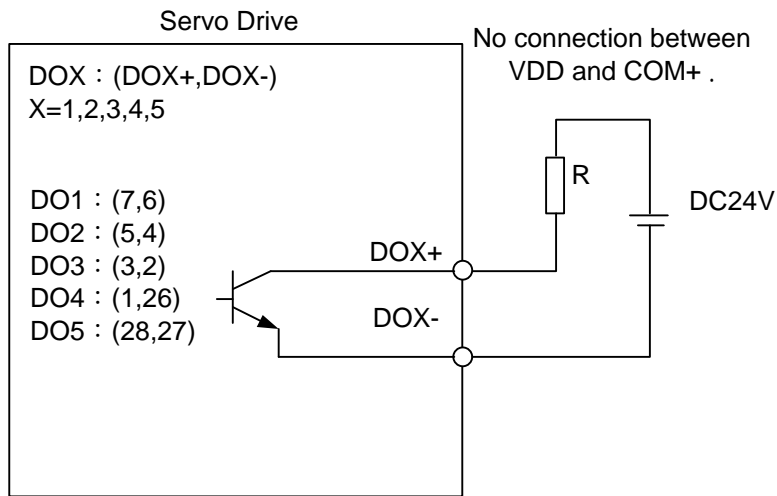

C8: Wiring of DO signal. The servo drive applies to the external power and the resistor is inductive load.

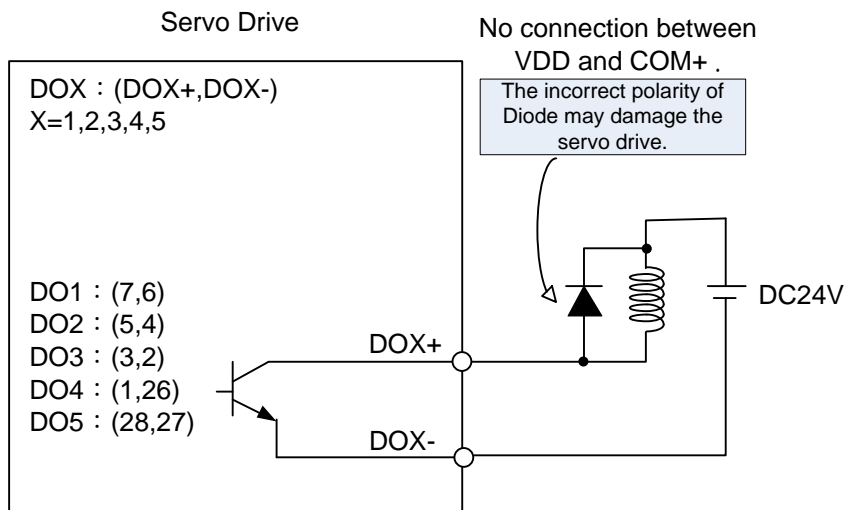

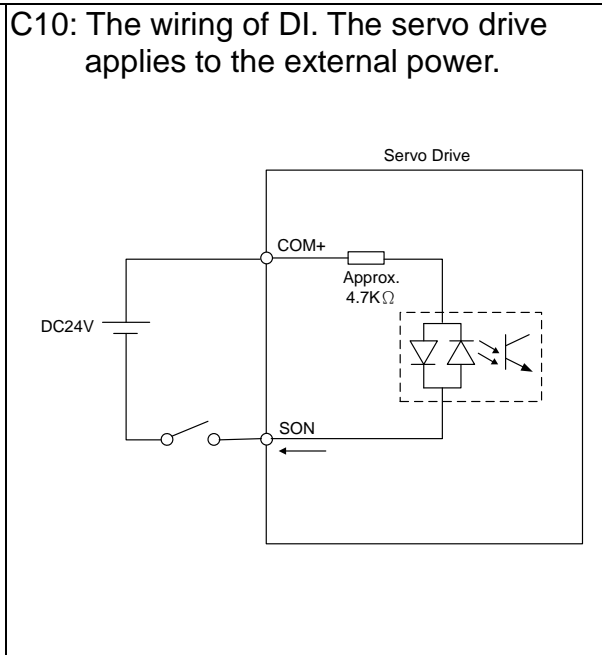
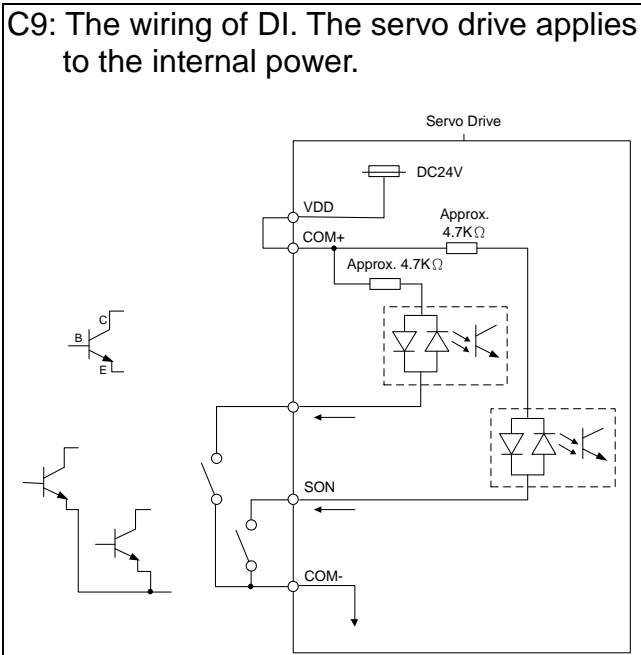

Input signal via relay or open-collector transistor

NPN transistor, common emitter (E) mode (SINK mode)

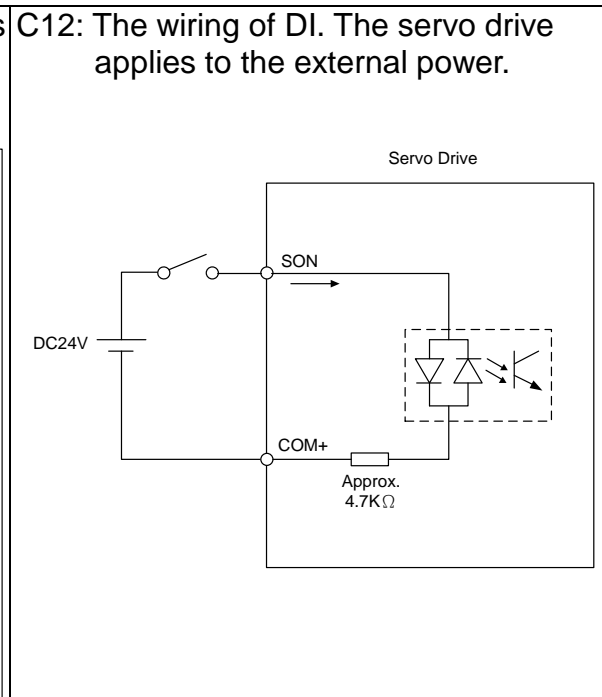
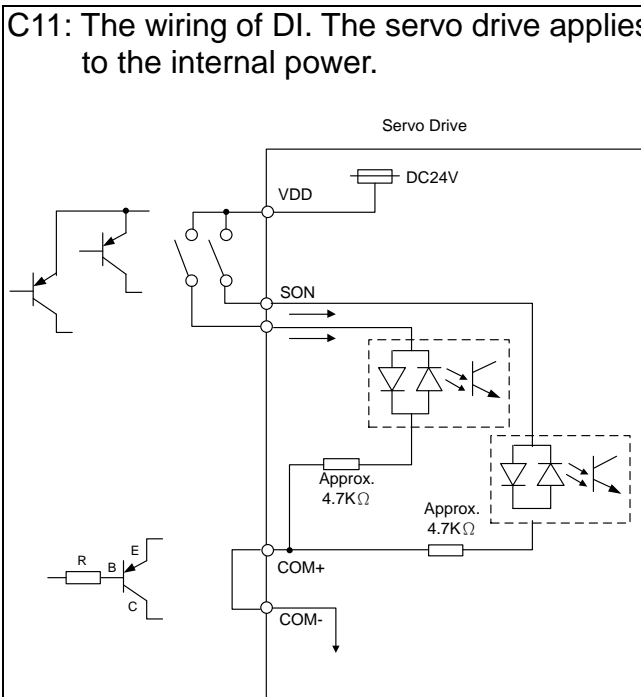

PNP transistor, common emitter (E) mode (SOURCE mode)



 **Caution: Do not apply to dual power or it may damage the servo drive.**

C13: Encoder signal output (Line driver)

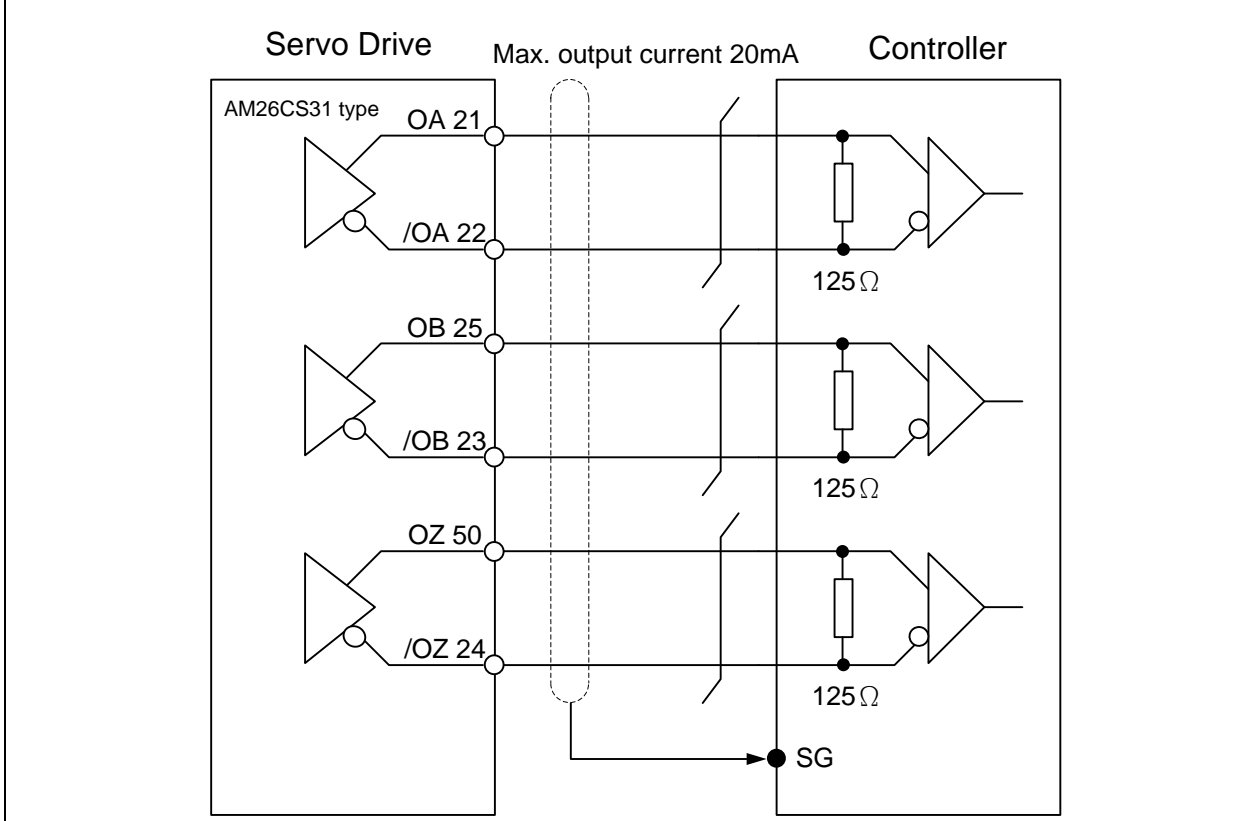

C14: Encoder signal output (Opto-isolator)

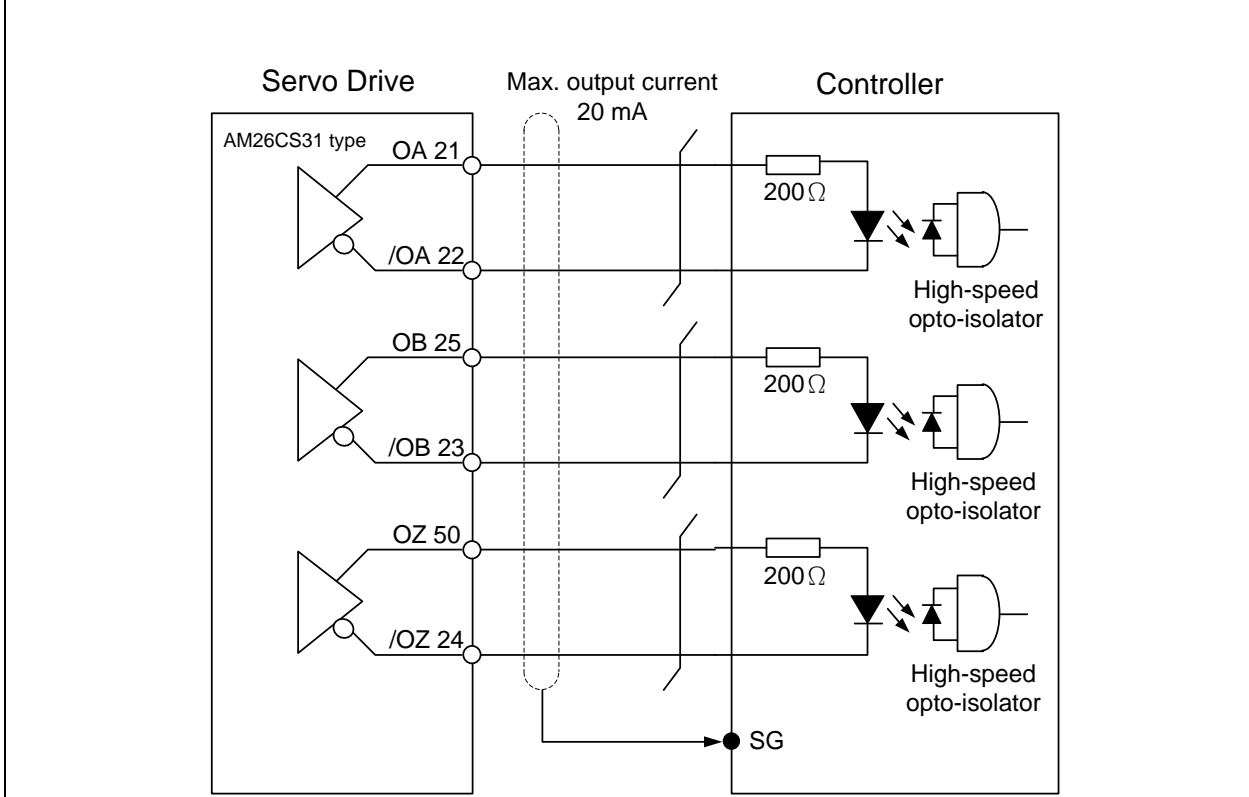

C15: Encoder OCZ output (open-collector Z pulse output)

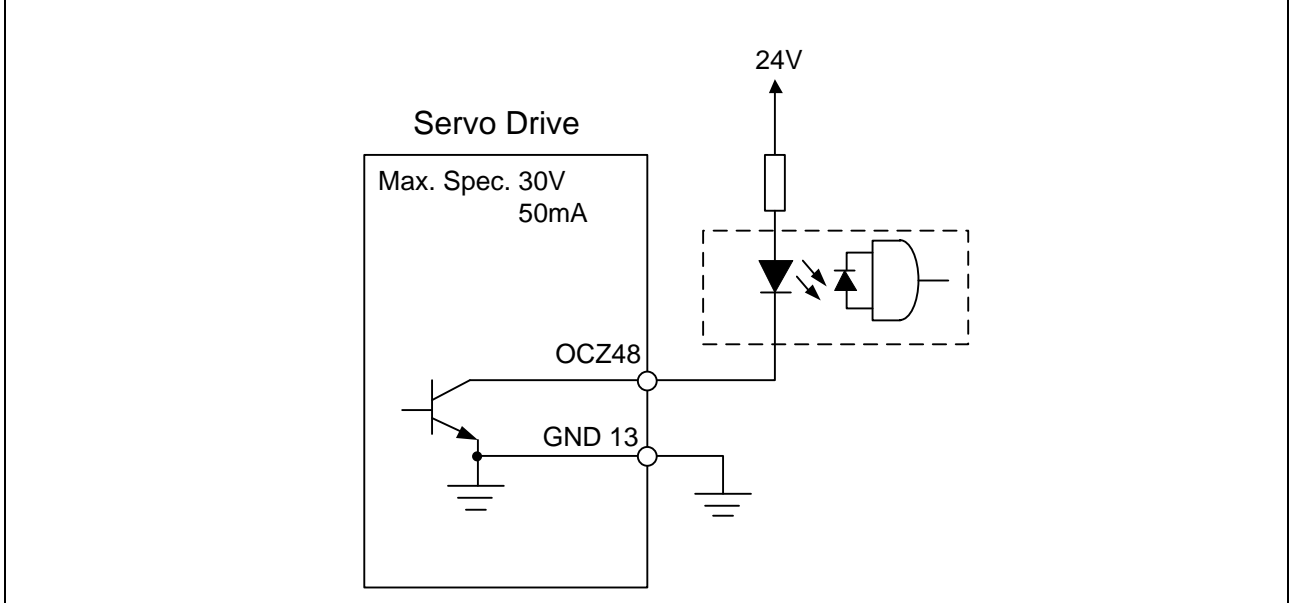

3.3.4 The DI and DO Signal Specified by the User

If the default setting of DI/DO signal cannot satisfy the need, self-set the DI/DO signal will do and easy. The signal function of DI1 ~ 8 and DO1 ~ 5 is determined by parameter P2-10 ~ P2-17 and parameter P2-18 ~ P2-22 respectively. Please refer to Chapter 7.2, which shown as the following table. Enter DI or DO code in the corresponding parameter to setup DI/DO.

Signal Name	Pin No	Corresponding Parameter	
Standard DI	DI1-	CN1-9	P2-10
	DI2-	CN1-10	P2-11
	DI3-	CN1-34	P2-12
	DI4-	CN1-8	P2-13
	DI5-	CN1-33	P2-14
	DI6-	CN1-32	P2-15
	DI7-	CN1-31	P2-16
	DI8-	CN1-30	P2-17
Extension DI (Optional)	EDI9	CN7-2	P2-36
	EDI10	CN7-3	P2-37
	EDI11	CN7-4	P2-38
	EDI12	CN7-5	P2-39
	EDI13	CN7-6	P2-40
	EDI14	CN7-7	P2-41

Signal Name	Pin No	Corresponding Parameter	
Standard DO	DO1+	CN1-7	P2-18
	DO1-	CN1-6	
	DO2+	CN1-5	P2-19
	DO2-	CN1-4	
	DO3+	CN1-3	P2-20
	DO3-	CN1-2	
	DO4+	CN1-1	P2-21
	DO4-	CN1-26	
	DO5+	CN1-28	P2-22
	DO5-	CN1-27	

3.3.5 Application: Wiring of CN1 Quick Connector

ASD-IF-SC5020 CN1 quick connector is designed for easy wiring. It is applicable to ASDA-A2 and ASDA-A2R series servo drive and can satisfy the demand of different DI/O application. It will be a good choice for those who do not want to self-weld the wiring rods. The vibration will not loosen the leading wire due to the design of spring terminal blocks. It is rather convenient and fast when wiring and under construction. 5 digital inputs, 4 digital outputs, pulse command inputs and Z phase open-collector outputs are included. Pin definition is as the following:

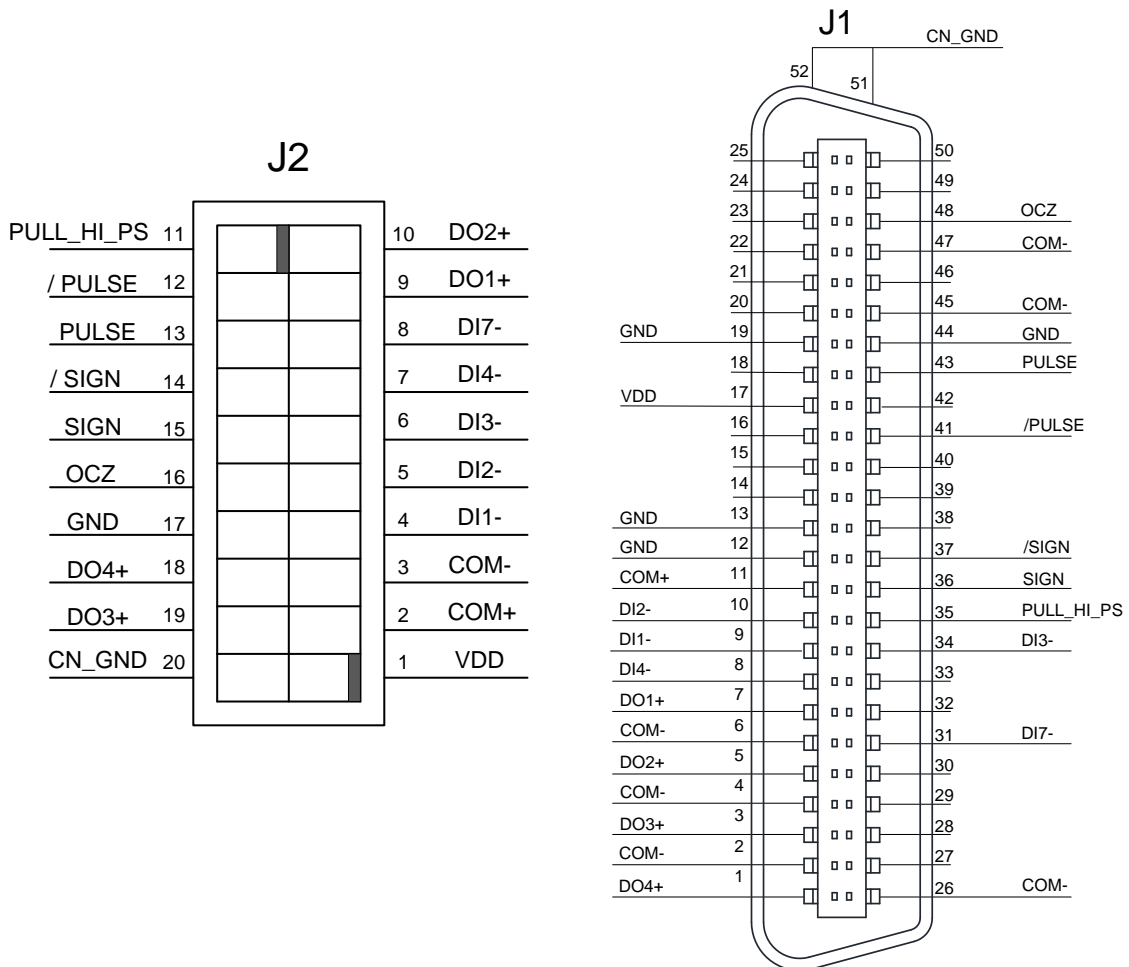
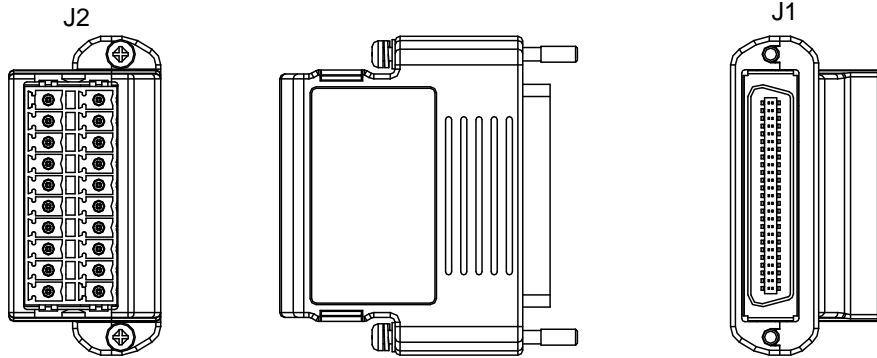

J2		J1	
PIN	Description	PIN	Description
1	VDD	17	VDD
2	COM+	11	COM+
3	COM-	2,4,6,26,45,47	COM-
4	DI1-	9	DI1-
5	DI2-	10	DI2-
6	DI3-	34	DI3-
7	DI4-	8	DI4-
8	DI7-	31	DI7-
9	DO1+	7	DO1+
10	DO2+	5	DO2+
11	PULL_HI_PS	35	PULL_HI_PS
12	/PULSE	41	/PULSE
13	PULSE	43	PULSE
14	/SIGN	37	/SIGN
15	SIGN	36	SIGN
16	OCZ	48	OCZ
17	GND	12,13,19,44	GND
18	DO4+	1	DO4+
19	DO3+	3	DO3+
20	CN_GND	51,52	CN_GND

Example of wiring:

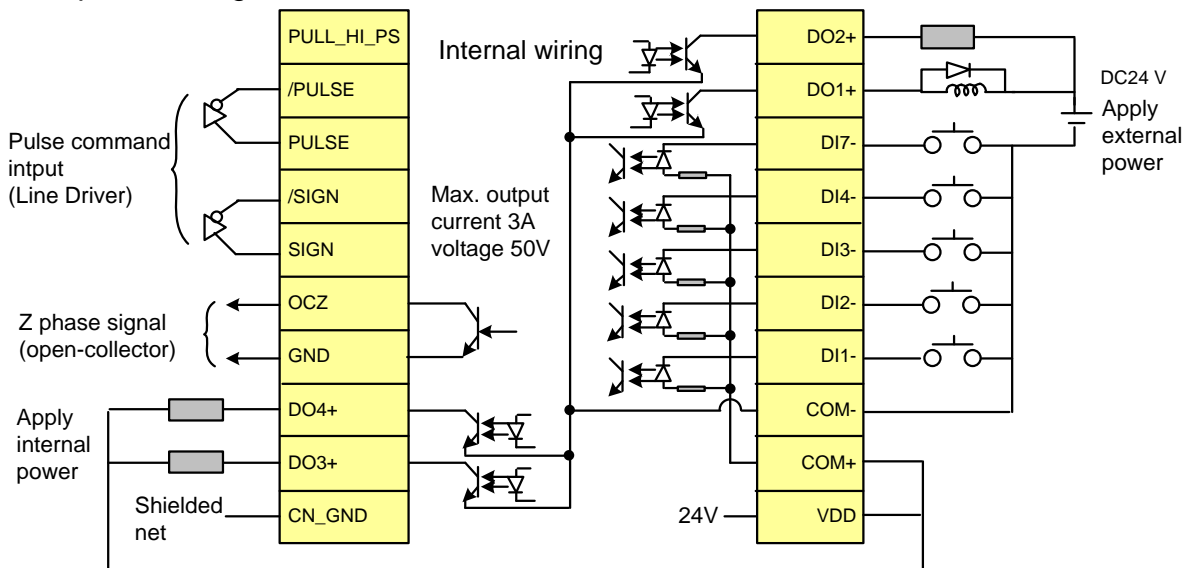

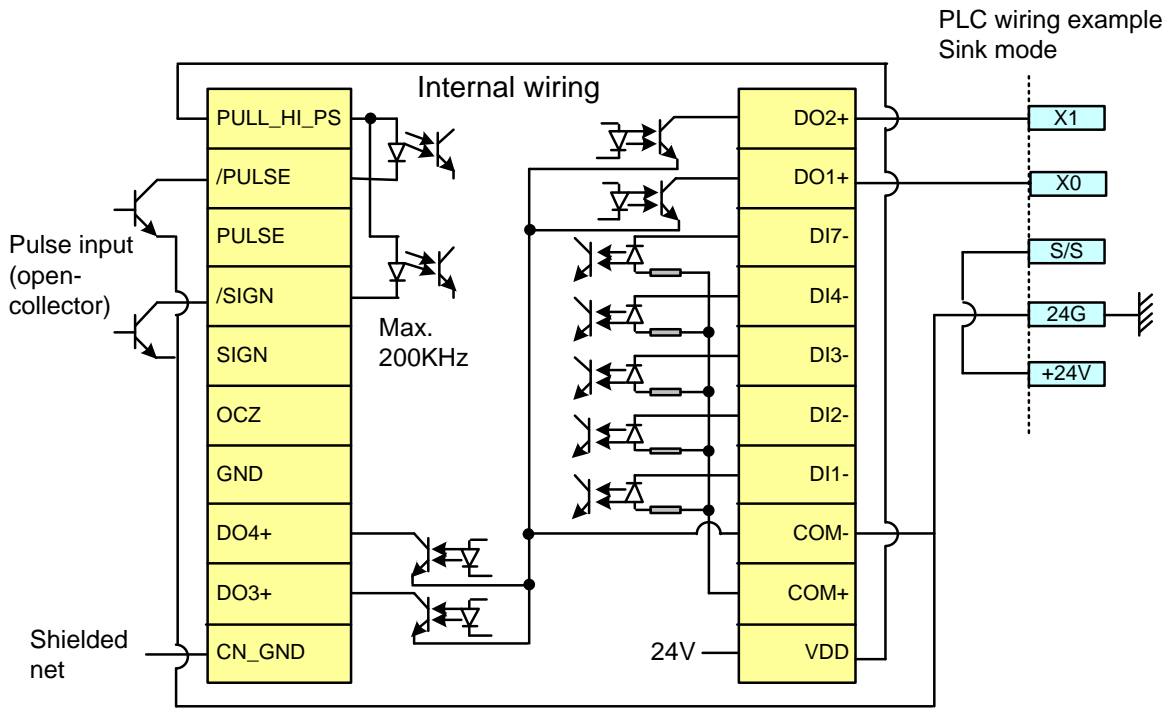

Wiring and installation of CN1 quick connector:

Wiring:

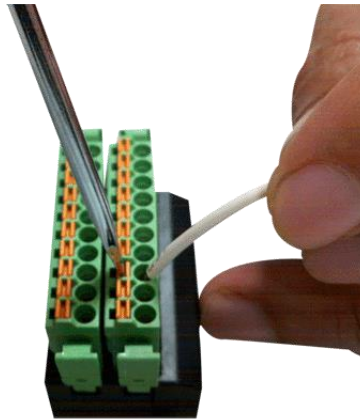

Installation:

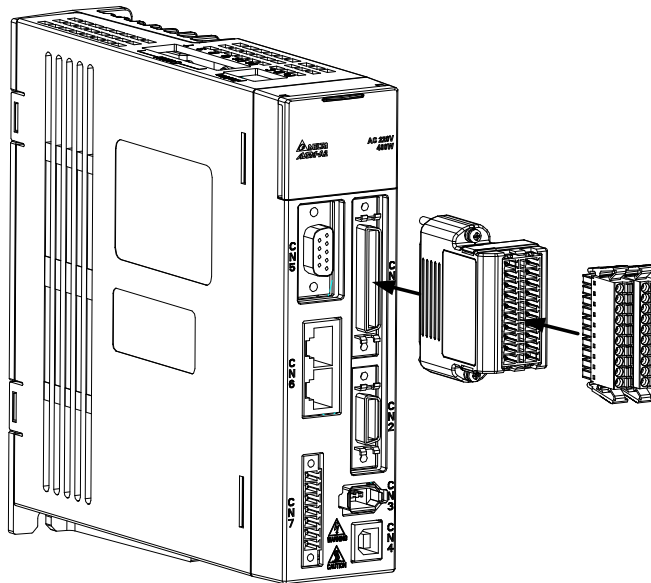

3.4 CN2 Connector

The terminal block of the connector and pin number are as follows:

(A) Encoder Connector:

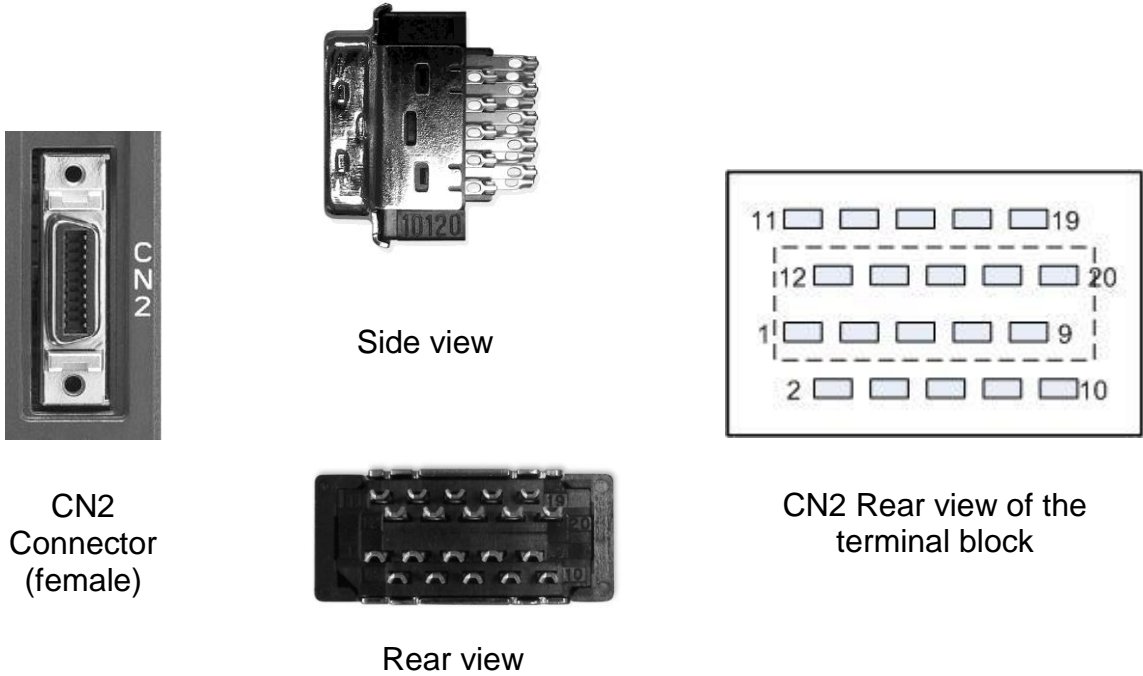

(B) Motor Connector:

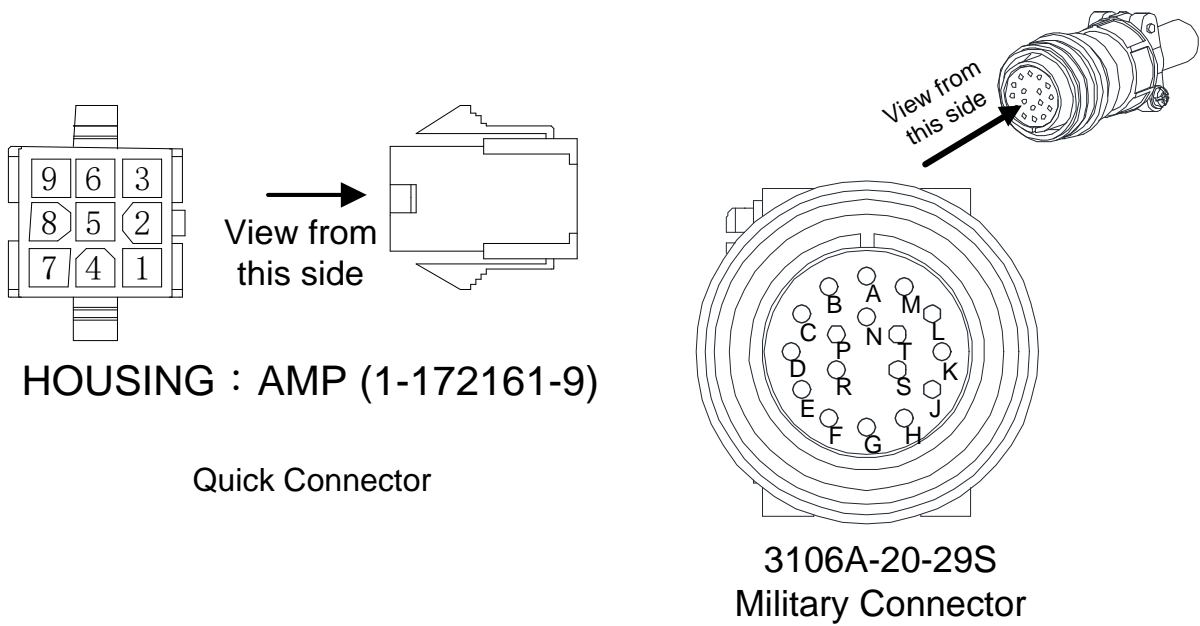

The definition of each signal is as follows:

Drive Connector			Motor Connector		
Pin No	Terminal Symbol	Function and Description	Military connector	Quick connector	Color
5	T+	Serial communication signal input/output (+)	A	1	Blue
4	T-	Serial communication signal input/output (-)	B	4	Blue & Black
-	-	Reserved	-	-	-
-	-	Reserved	-	-	-
14,16	+5V	Power + 5 V	S	7	Red / Red & White
13,15	GND	Power ground	R	8	Black / Black & White
Shell	Shielding	Shielding	L	9	-

The shielding procedures of CN2 encoder connector are as the followings:



- (1) Cut through the cable and expose the core wire which covers the metal core wires with shielding. The length of the reserved core wire should be 20~30mm. Then, cover a 45mm long heat shrink tube on the cable.

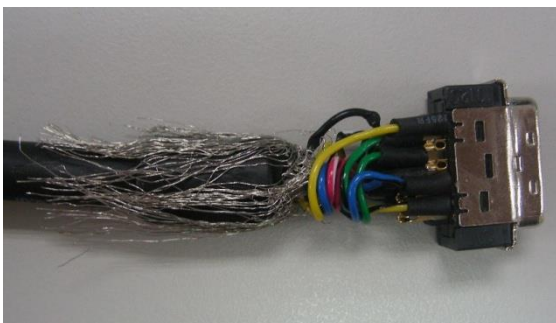

- (2) Spread the metal core wires with shielding and turn it upside down in downward direction. Ensure to follow the pin definition from the above table to connect the pins one by one.

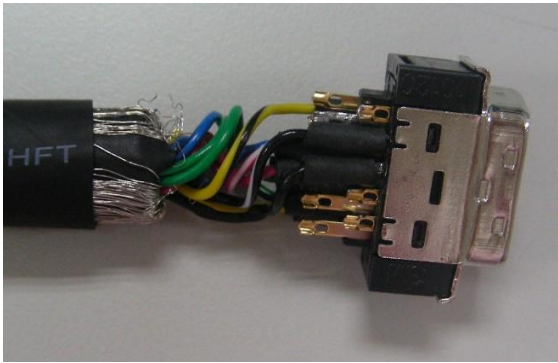

(3) Leave a length of 5~10mm metal core wires with shielding outside the cable. The length is about the width of the metal saddle. The other unexposed wires of the cable should be protected by the heat shrink tube for good ground contact.

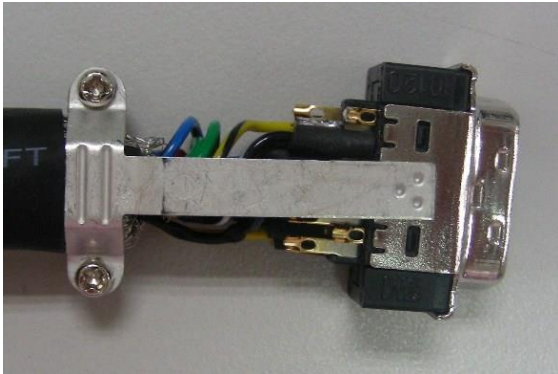

(4) Install a metal saddle to fix the exposed metal core wires. The metal saddle must completely cover all the exposed metal core wires. The extended sheet metal should be connected to the metal part of the connector.

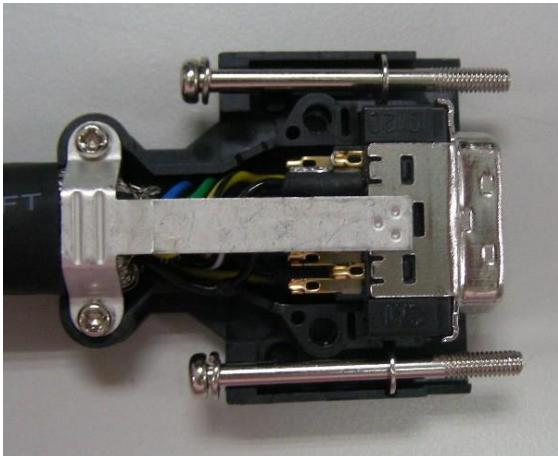

(5) Install the connector into the plastic case as shown in the figure.



(6) Tighten the screws to complete a shielded CN2 connector.

3.5 Wiring of CN3 Connector

3.5.1 Layout of CN3 Connector

The servo drive connects to the personal computer via communication connector. The user can operate the servo drive, PLC, or HMI via MODBUS using the assembly language. The commonly-used communication interface RS-485 is provided and can be set by P3-05. Its transmission distance is longer and supports more than one servo drives for connection.

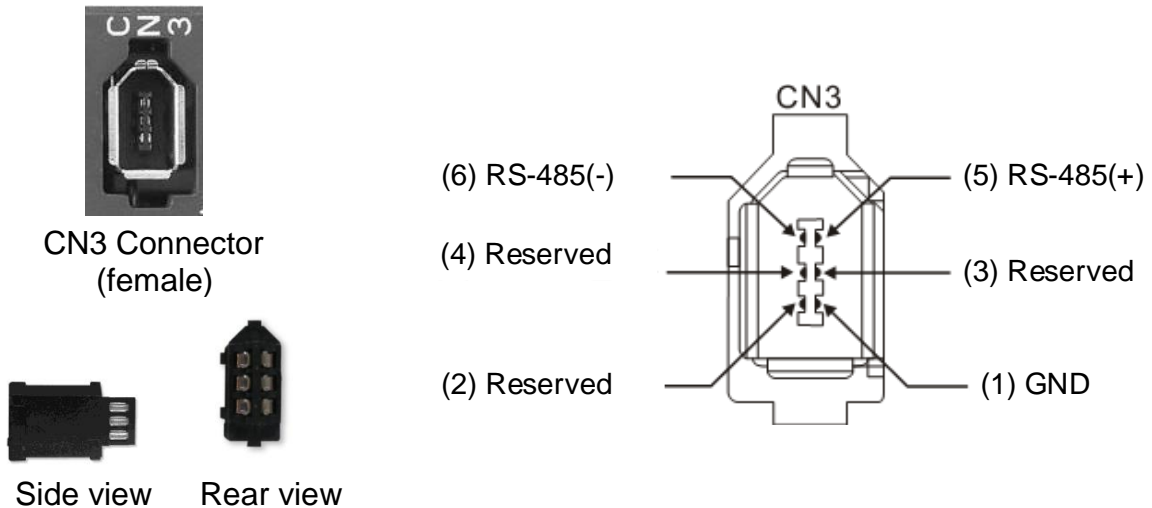

Pin No	Signal Name	Terminal Symbol	Function and Description
1	Signal grounding	GND	+ 5 V connects to the signal terminal
2	-	-	Reserved
3	-	-	Reserved
4	-	-	Reserved
5	RS-485 data transmission	RS-485(+)	The drive transmits the date to differential terminal (+)
6	RS-485 data transmission	RS-485(-)	The drive transmits the date to differential terminal (-)

Note:

- 1) Please refer to Chapter 9 for the wiring of RS-485.
- 2) Two kinds of communication wire of IEEE1394 are commercially available. One of the internal ground terminals (Pin 1) will short circuit with the shielding and will damage the drive. Do not connect GND to the shielding.

3.5.2 Connection between CN3 Connector and Personal Computer

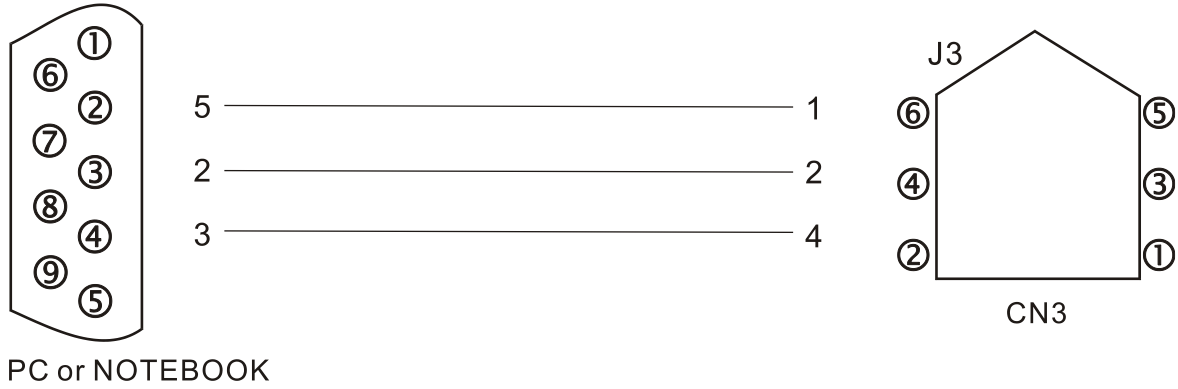

3.6 CN4 Serial Connector (USB)

CN4 is a serial connector which used to connect PC software and enhance the efficiency. The transmission speed of USB can up to 1MB, that is to say PC Data Scope can obtain the correct data in time.

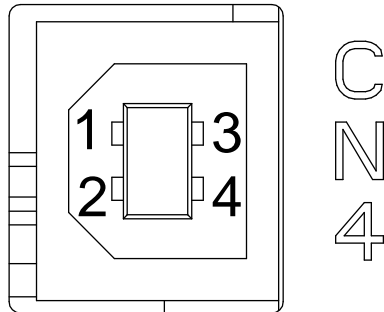

CN4 Connector (female)

Pin No	Signal Name	Function and Description
1	V bus	DC + 5 V (external power supply)
2	D-	Data-
3	D+	Data+
4	GND	Ground

3.7 CN5 Connector (Full-closed Loop)

Connect to the external linear scale or encoder (A, B, Z) and form a full-closed loop with the servo. In position mode, the pulse position command issued by the controller is based on the control loop of the external linear scale. Please refer to Chapter 6.

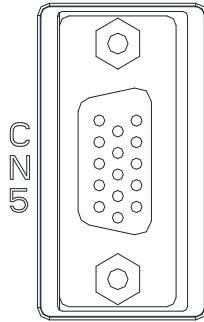

CN5 Connector (female)

Pin No	Signal Name	Terminal Symbol	Function and Description
1	/Z phase input	Opt_/Z	/Z phase input
2	/B phase input	Opt_/B	/B phase input
3	B phase input	Opt_B	B phase input
4	A phase input	Opt_A	A phase input
5	/A phase input	Opt_/A	/A phase input
6	Encoder grounding	GND	Ground terminal for encoder and Hall sensor
7	Encoder grounding	GND	Ground terminal for encoder and Hall sensor
8	Encoder power	+ 5 V	+ 5 V power
9	Z phase input	Opt_Z	Z phase input
10	Hall sensor U phase input	HALL_U	Hall sensor U phase input
11	Hall sensor V phase input	HALL_V	Hall sensor V phase input
12	Hall sensor W phase input	HALL_W	Hall sensor W phase input
13	Motor temperature detection	TEMP+	Motor temperature detection
14	Motor temperature detection	TEMP-	Motor temperature detection
15	Reserved	Reserved	Reserved

Note:

- 1) It only supports AB phase signal and the encoder with 5 V.
- 2) Application of full-closed loop: It supports the encoder with highest resolution, 1280000 pulse / rev (Full-closed loop corresponds to the resolution of quadruple frequency when motor runs a cycle.).
- 3) It supports NTC, PTC type of temperature sensor.

3.8 CN6 Connector (CANopen)

Based on the standard of CANopen DS301 and DS402, CN6 uses the standard CAN interface to implement position, torque and speed mode. It also can read or monitor the drive status.

The station number of CANopen is the same as RS-485. All are set via parameter P3-00 and the transmission rate can up to 1 Mbps. It provides two sets of communication connectors, one is for receiving and another one is for transmission, in order to connect more than one drives. The last servo drive connects to termination resistor.

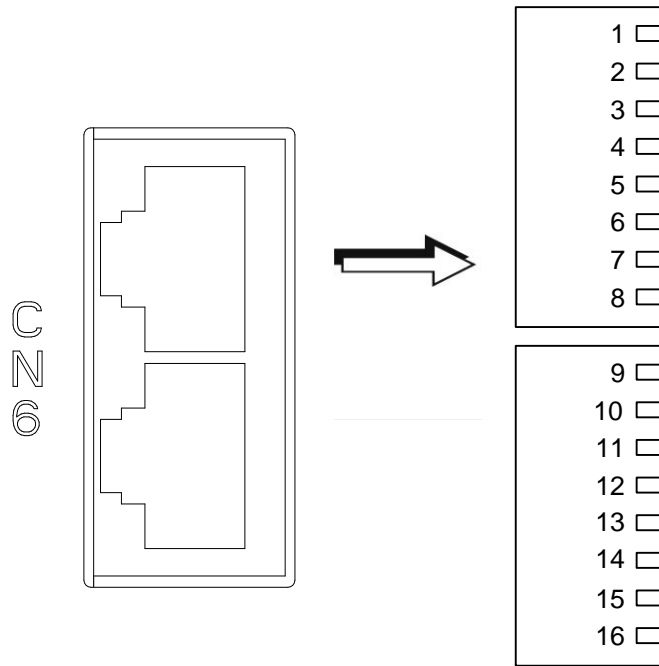

CN6 Connector (female)

Pin No	Signal Name	Function and Description
1, 9	CAN_H	CAN_H bus line (dominant high)
2, 10	CAN_L	CAN_H bus line (dominant low)
3, 11	CAN_GND	Ground / 0 V / V -
4, 12	-	-
5, 13	-	-
6, 14	-	-
7, 15	CAN_GND	Ground / 0 V / V -
8, 16	-	-

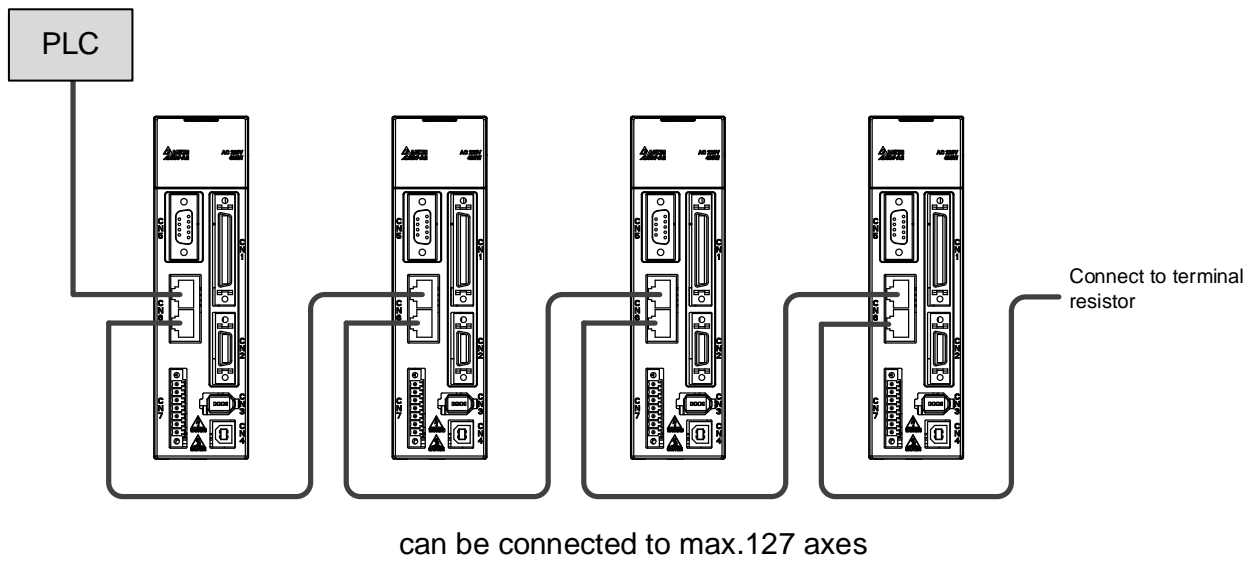

Note:

- 1) The termination resistor is suggested to use 120 Ω (Ohm) 0.25W or above.
- 2) The wiring method of concatenate more than one drives is based on two terminals of CANopen. One is for receiving and another one is for transmission. And the servo drive connects to the termination resistor. The wiring diagram of the termination resistor is shown as the followings:

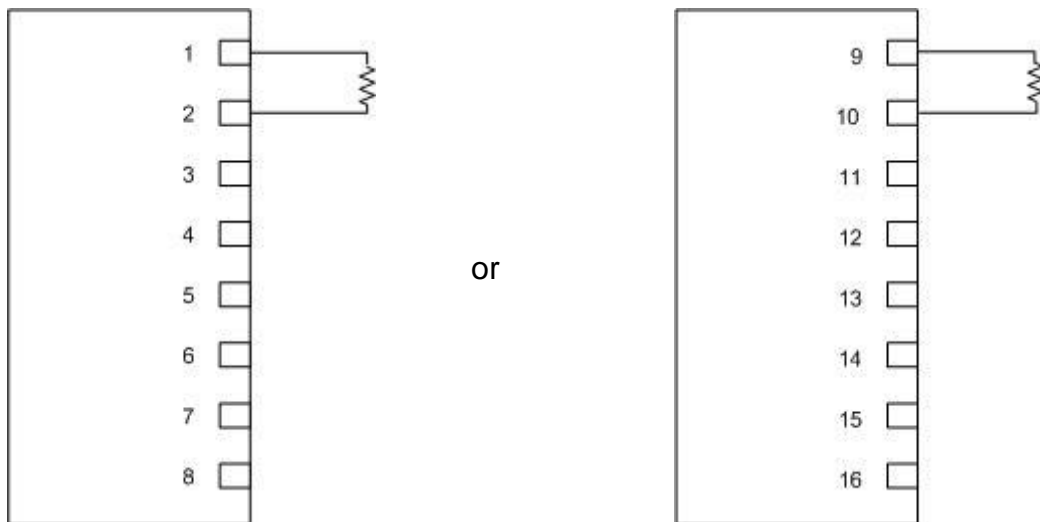

3.9 Extension Digital Input Connector of CN7

A2R series servo drive, A2R-U, provides additional extension DI on CN7 port. The function of this DI is similar to the one on CN1. Users can self-define and program it according to the demand.

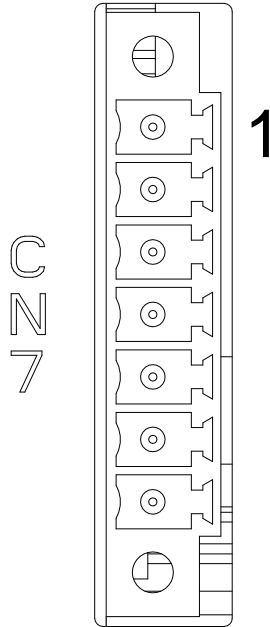

CN7 Connector (female)

Pin No	Signal Name	Terminal Symbol	Function and Description
*1	VDD24 V power	COM+	Power of VDD(24V) should be the same as Pin 11 of CN1
2	Extension DI9	EDI 9-	Digital input DI9-
3	Extension DI10	EDI 10-	Digital input DI 10-
4	Extension DI11	EDI 11-	Digital input DI 11-
5	Extension DI12	EDI 12-	Digital input DI 12-
6	Extension DI13	EDI 13-	Digital input DI 13-
7	Extension DI14	EDI 14-	Digital input DI 14-



➤ ***1 Caution: Do not use dual power supply or it might damage the servo drive.**

3.10 Standard Wiring Method

3.10.1 Position (PT) Mode Standard Wiring

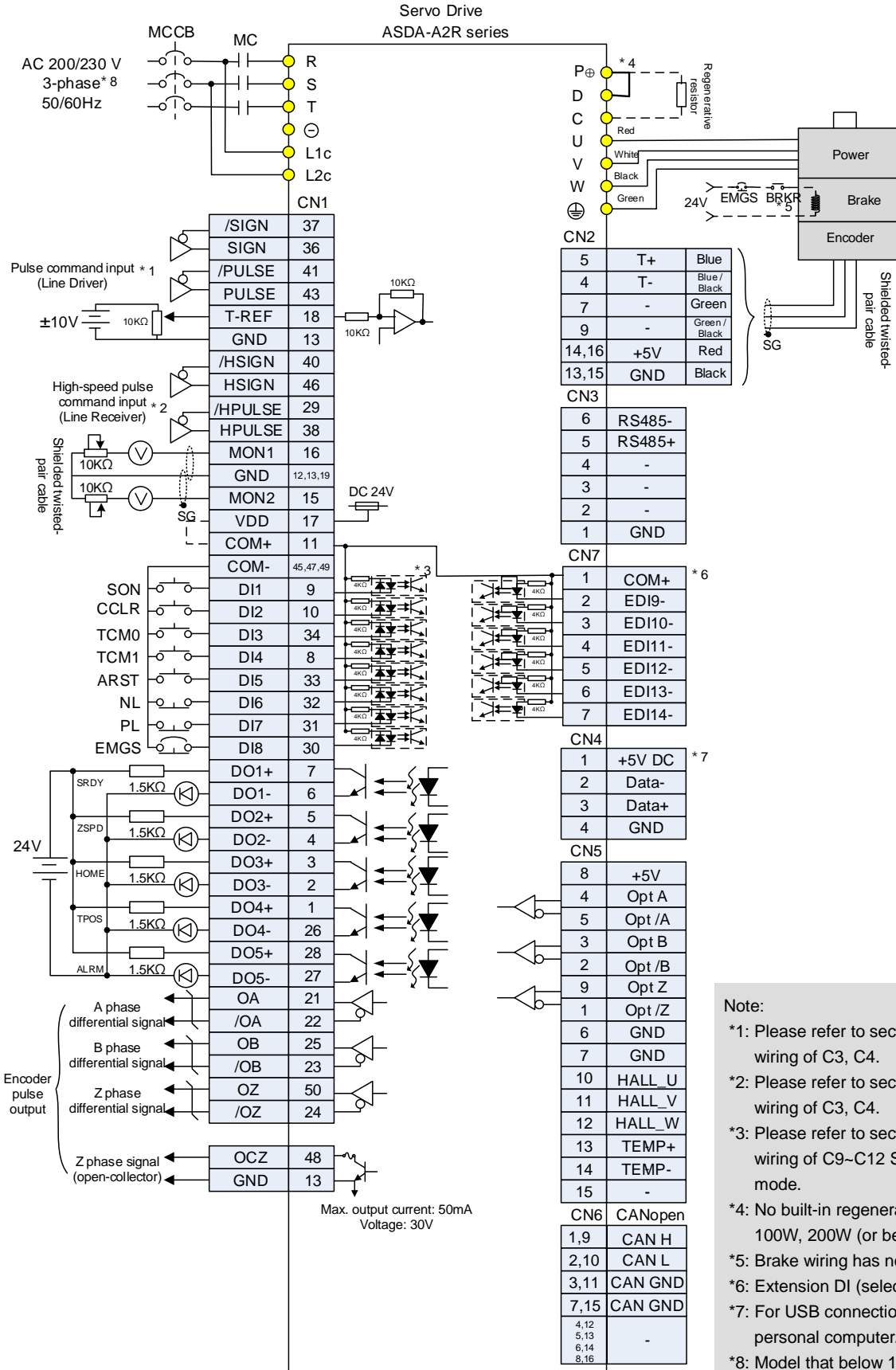

Note:

- *1: Please refer to section 3.3.3 for the wiring of C3, C4.
- *2: Please refer to section 3.3.3 for the wiring of C3, C4.
- *3: Please refer to section 3.3.3 for the wiring of C9~C12 SINK / SOURCE mode.
- *4: No built-in regenerative resistor for 100W, 200W (or below) servo drives.
- *5: Brake wiring has no polarity.
- *6: Extension DI (selective)
- *7: For USB connection. It connects to personal computer.
- *8: Model that below 1.5kW can apply single-phase power.

3.10.2 Position (PR) Mode Standard Wiring

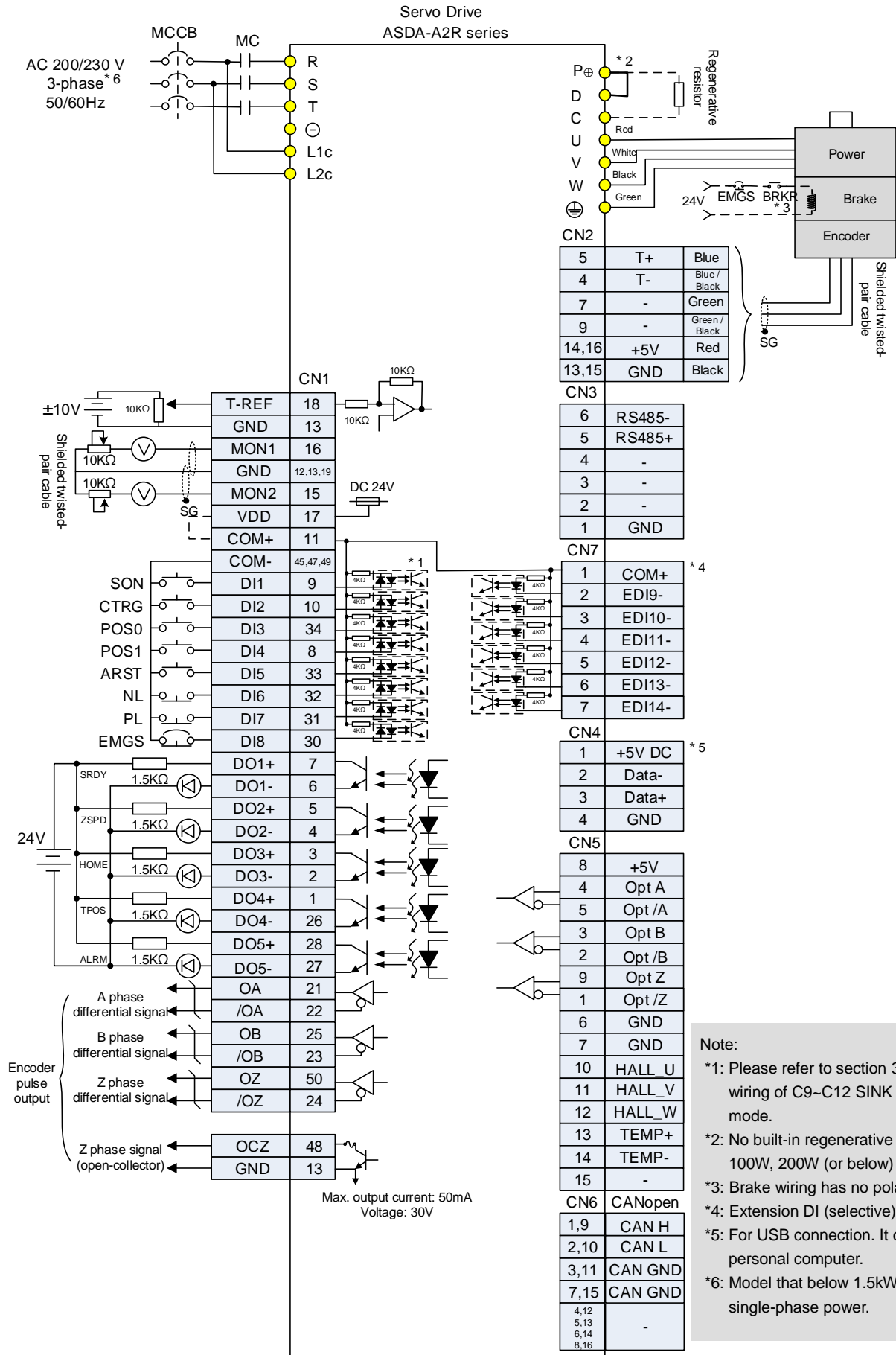

3.10.3 Speed Mode Standard Wiring

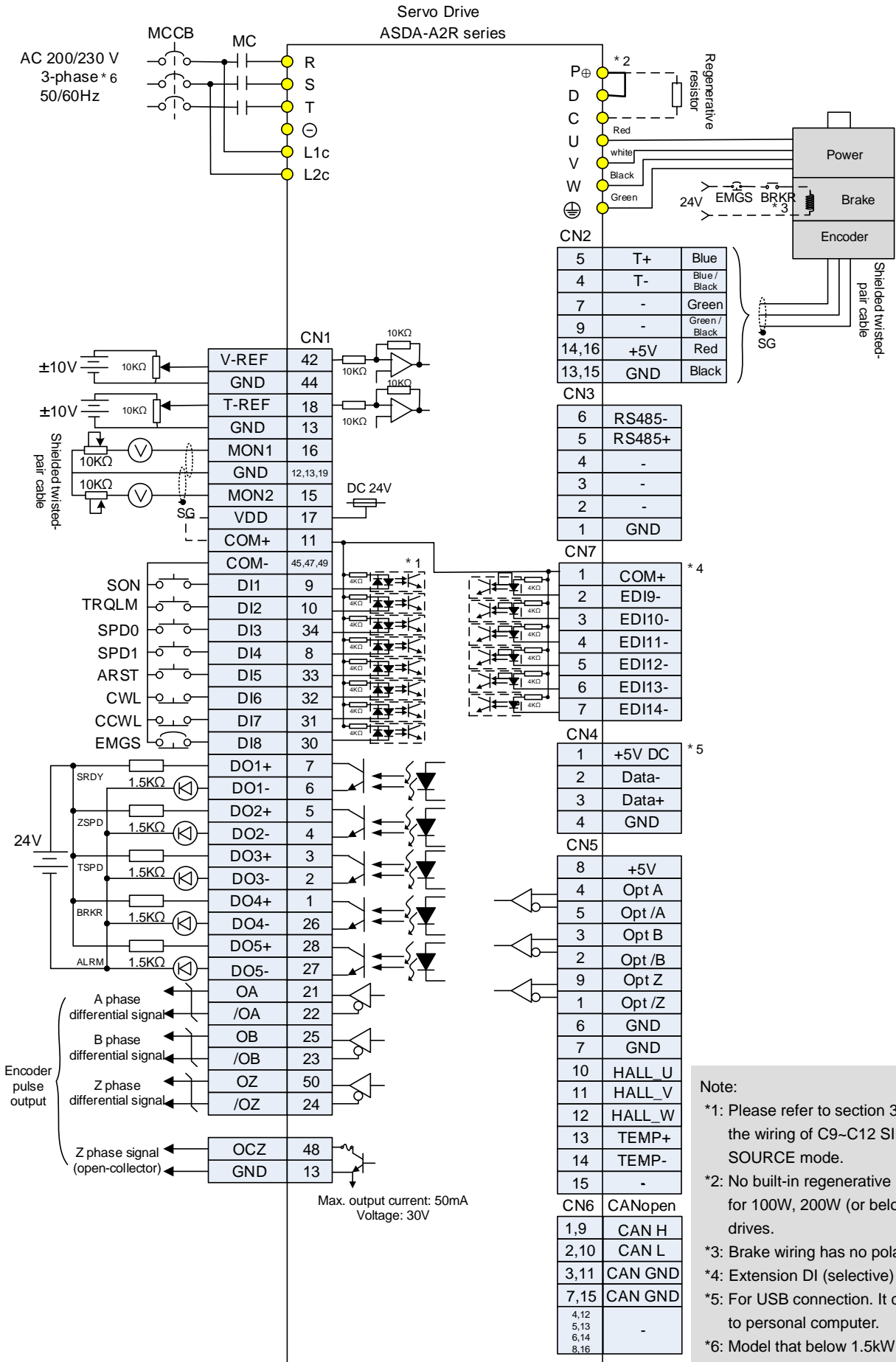

Note:

- *1: Please refer to section 3.3.3 for the wiring of C9~C12 SINK / SOURCE mode.
- *2: No built-in regenerative resistor for 100W, 200W (or below) servo drives.
- *3: Brake wiring has no polarity.
- *4: Extension DI (selective)
- *5: For USB connection. It connects to personal computer.
- *6: Model that below 1.5kW can apply single-phase power.

3.10.4 Torque Mode Standard Wiring

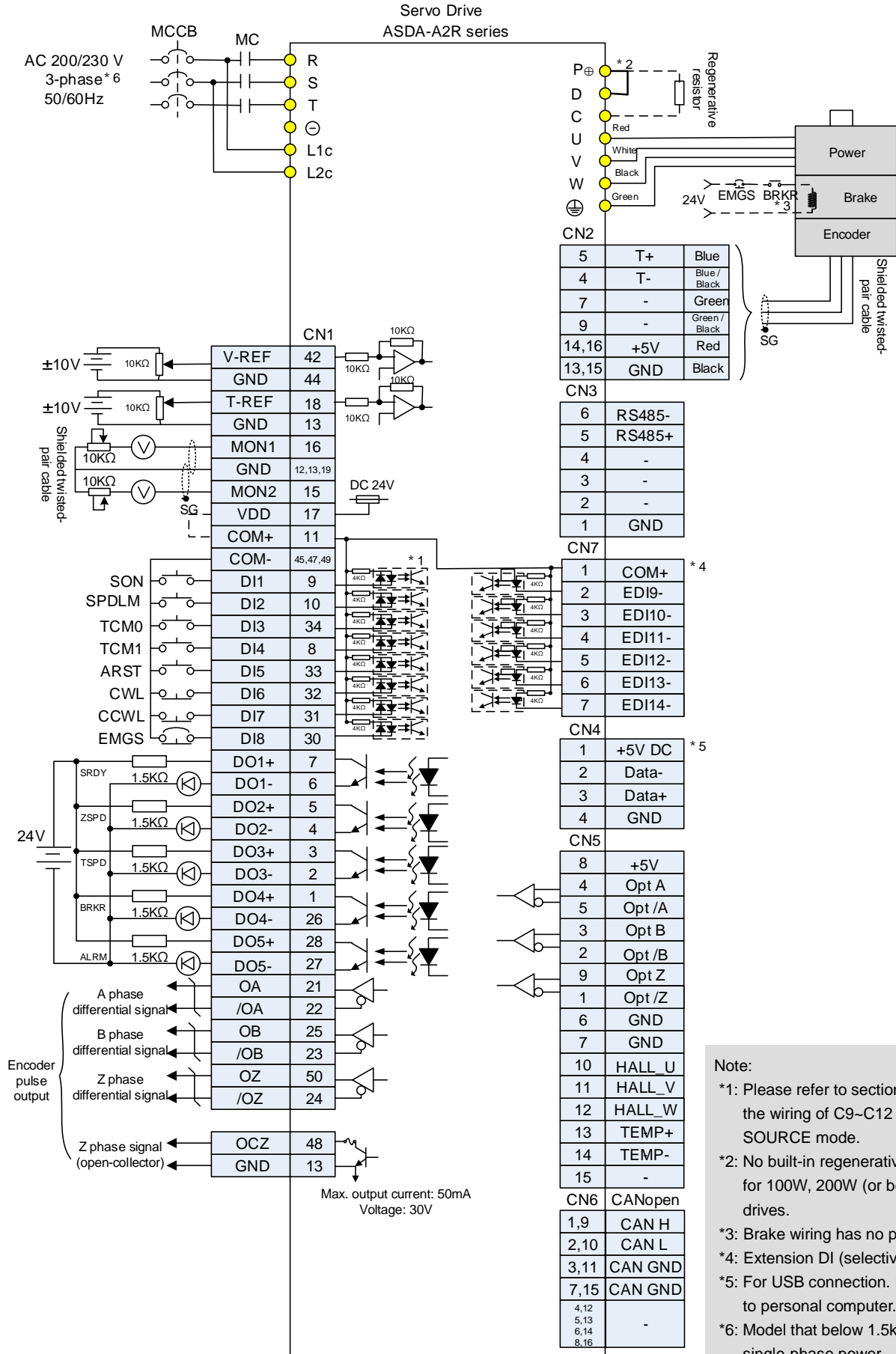

Note:

- *1: Please refer to section 3.3.3 for the wiring of C9-C12 SINK / SOURCE mode.
- *2: No built-in regenerative resistor for 100W, 200W (or below) servo drives.
- *3: Brake wiring has no polarity.
- *4: Extension DI (selective)
- *5: For USB connection. It connects to personal computer.
- *6: Model that below 1.5kW can apply single-phase power.

3.10.5 CANopen Mode Standard Wiring

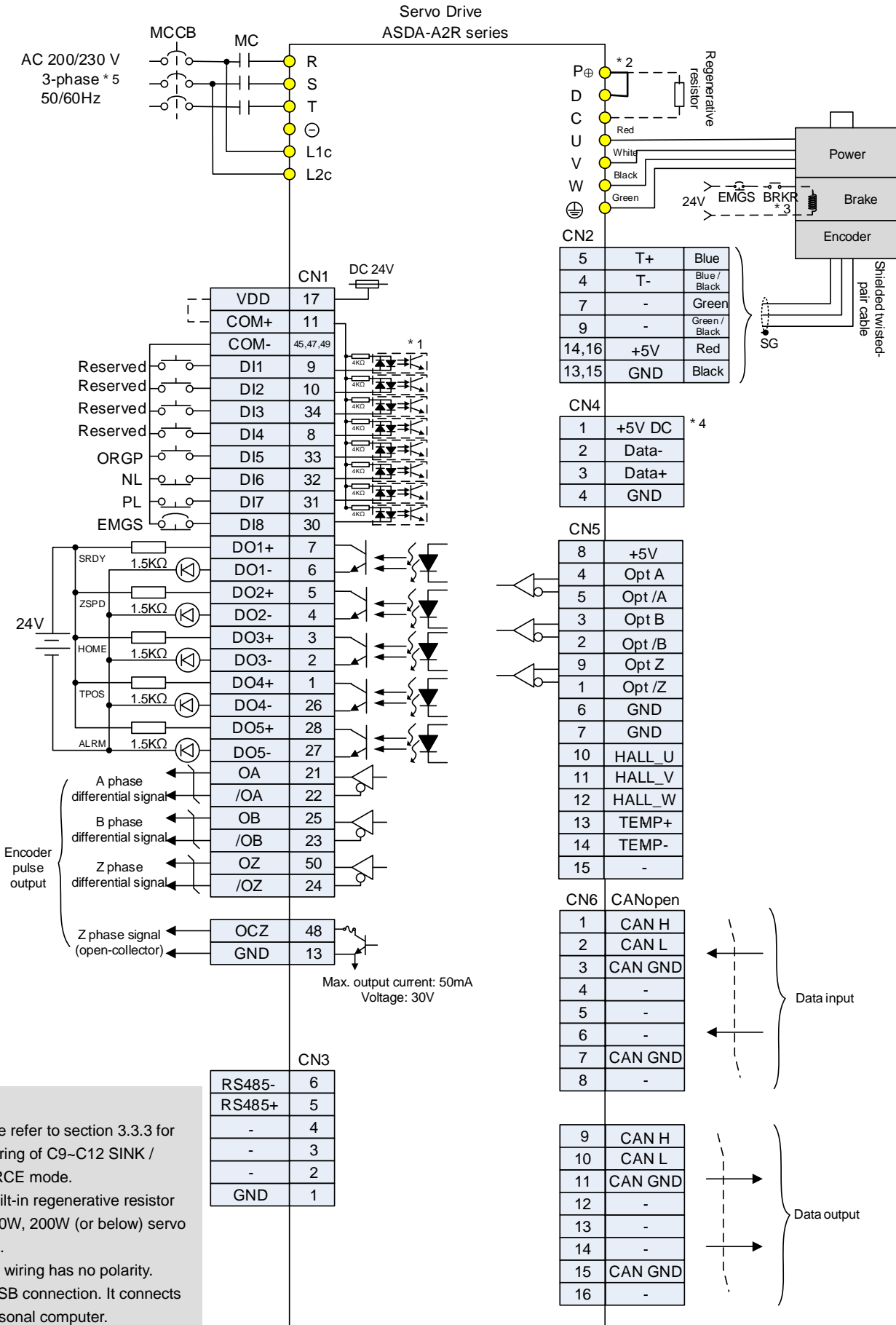

3.11 Wiring System of other Brand of Motor

3.11.1 Wiring Diagram of Peripheral Devices

Connect Communication Type of Motor to CN2

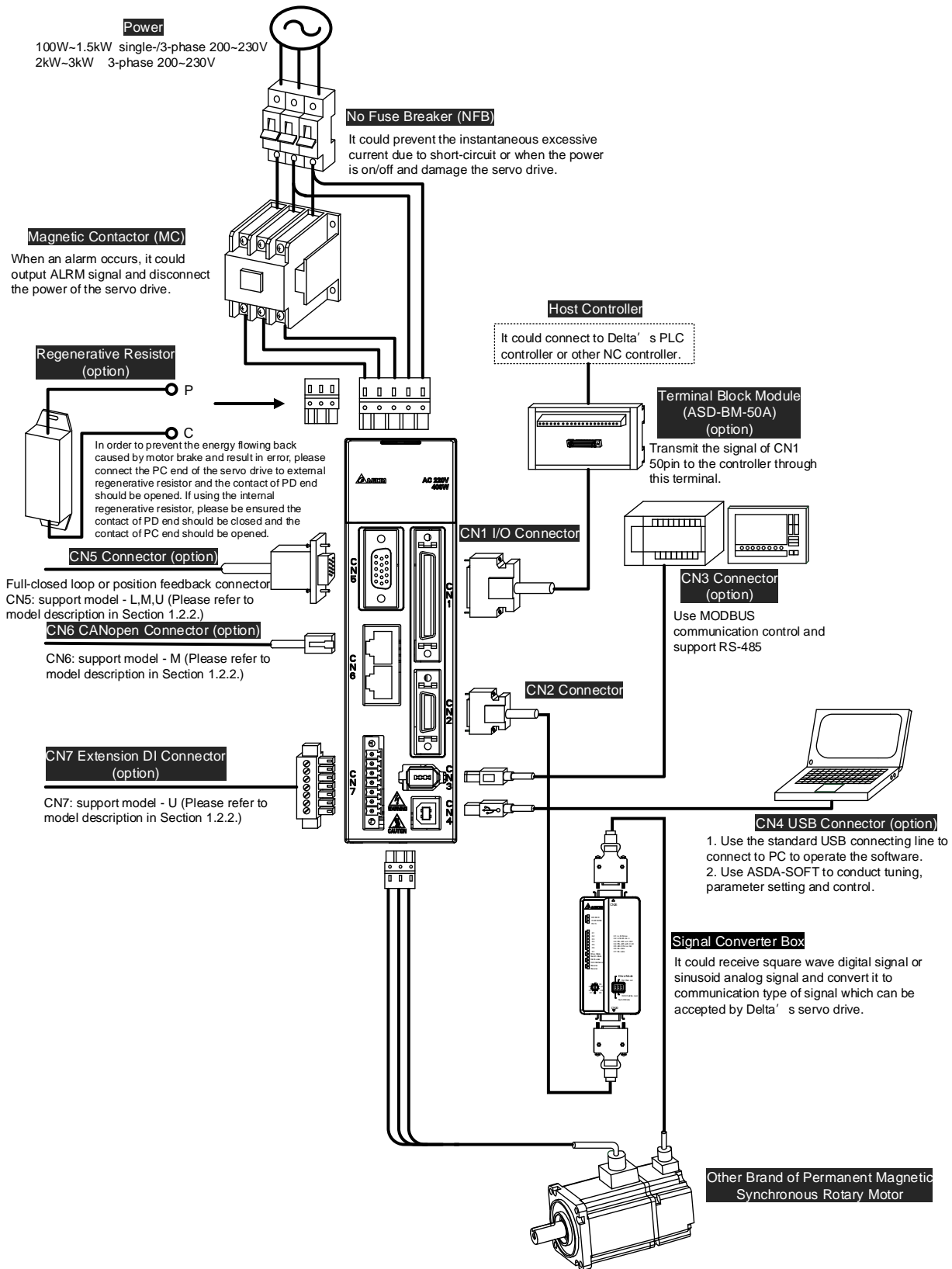

Connect Communication Type of Motor to CN5

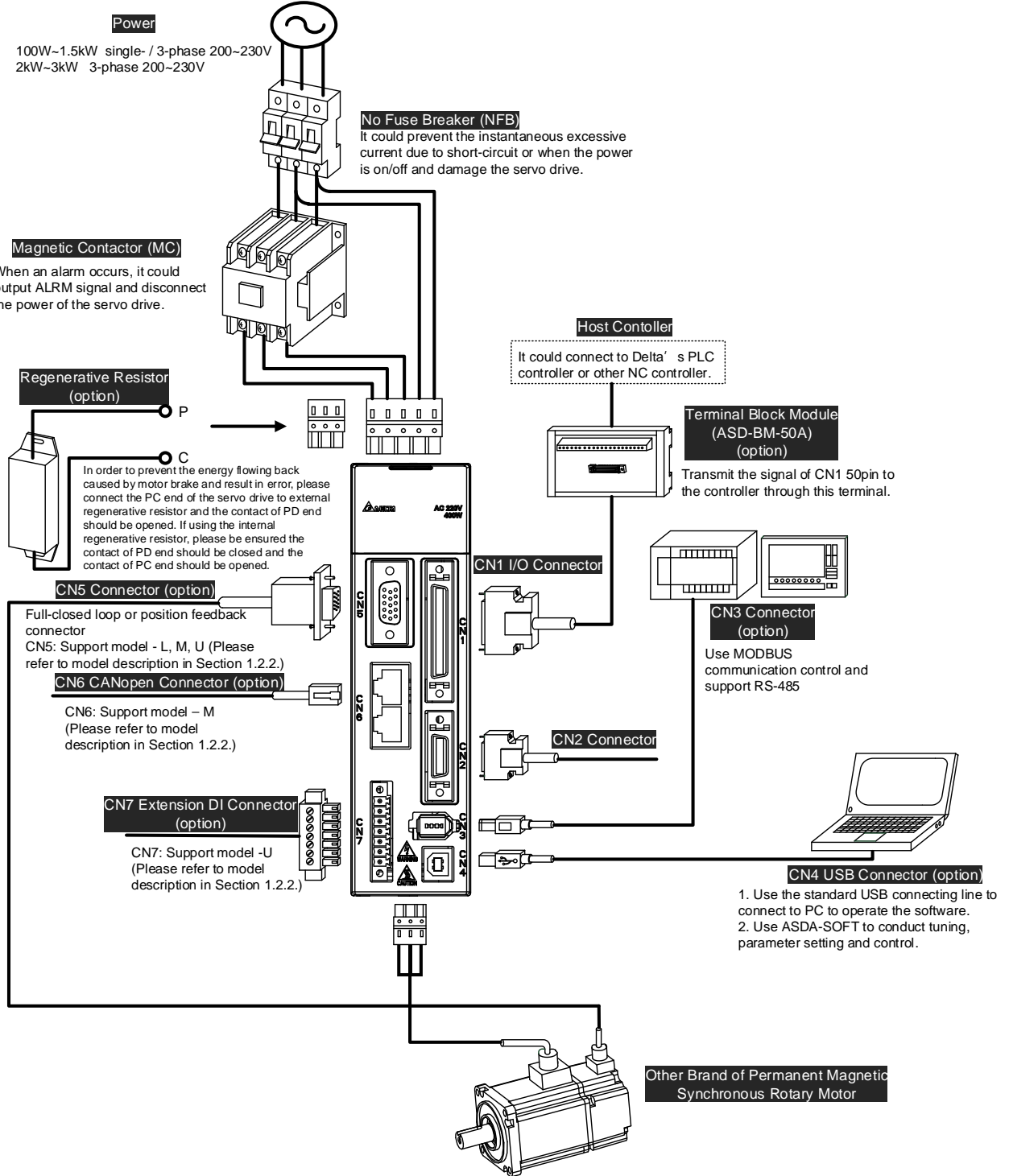

Connect Linear Motor to CN2

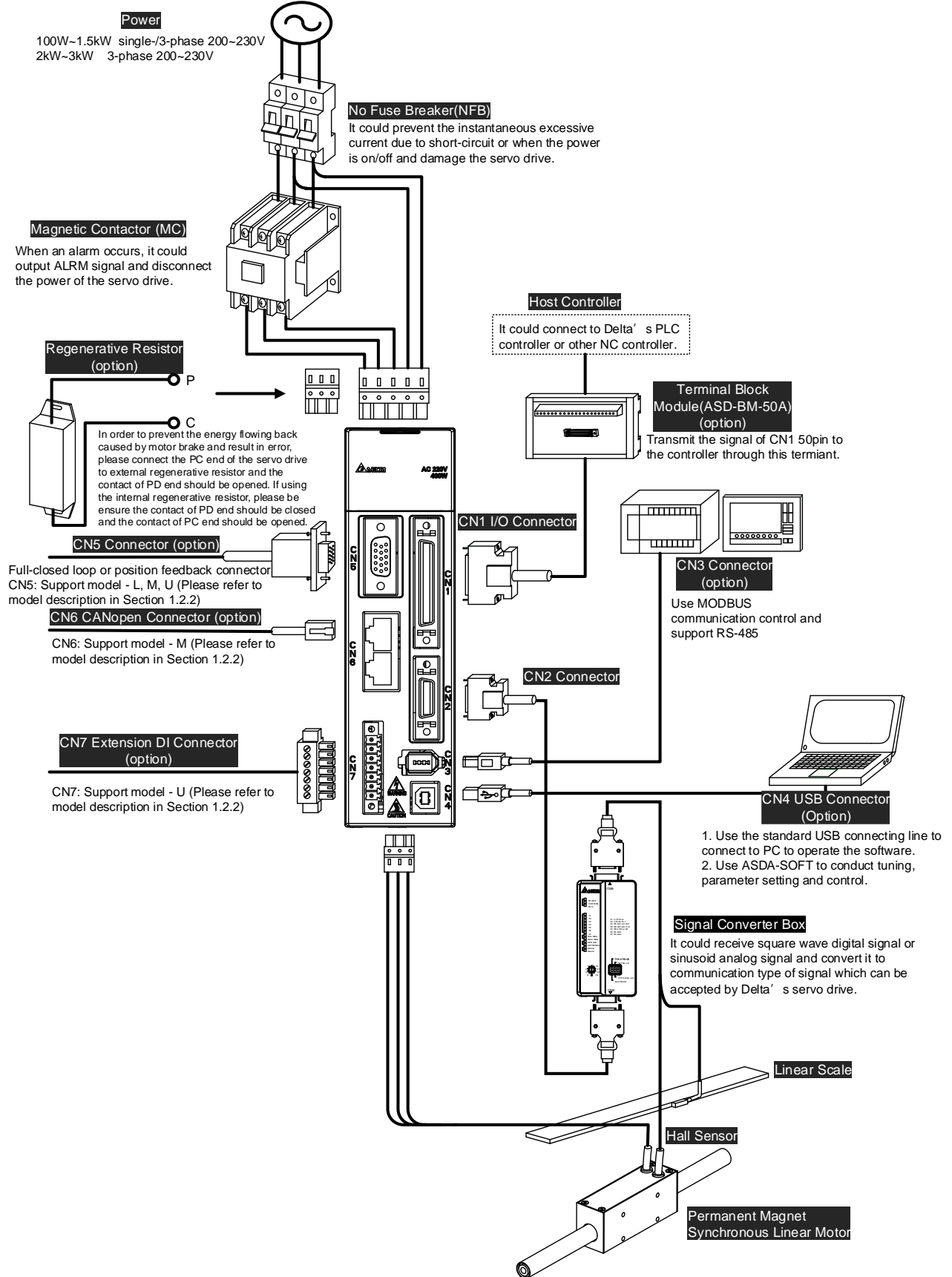

Connect Linear Motor to CN5

Power
 100W~1.5kW single-/3-phase 200~230V
 2kW~3kW 3-phase 200~230V

No Fuse Breaker (NFB)

It could prevent the instantaneous excessive current due to short-circuit or when the power is on/off and damage the servo drive.

Magnetic Contactor (MC)

When an alarm occurs, it could output ALRM signal and disconnect the power of the servo drive.

Regenerative Resistor (option)

In order to prevent the energy flowing back caused by motor brake and result in error, please connect the PC end of the servo drive to external regenerative resistor and the contact of PD end should be opened. If using the internal regenerative resistor, please be ensured the contact of PD end should be closed and the contact of PC end should be opened.

CN5 Connector (option)

Full-closed loop or position feedback connector
 CN5: Support model -L, M, U
 (Please refer to model description in Section 1.2.2.)

CN6 CANopen Connector (option)

CN6: Support model -M
 (Please refer to model description in Section 1.2.2.)

CN7 Extension DI Connector (option)

CN7: Support model -U
 (Please refer to model description in Section 1.2.2.)

Hall Sensor / Temperature Sensor

Host Controller

It could connect to Delta's PLC controller or other NC controller.

Terminal Block Module (ASD-BM-50A) (option)

Transmit the signal of CN1 50pin to the controller through this terminal.

CN3 Connector (option)

Use MODBUS communication control and support RS-485

CN1 I/O Connector

CN2 Connector

CN4 USB connector (option)

1. Use the standard USB connecting line to connect to PC to operate the software.
2. Use ASDA-SOFT to conduct tuning, parameter setting and control.

Linear Scale

Permanent Magnet Synchronous Linear Motor

3.11.2 Specification and Definition of ECML Motor Cable

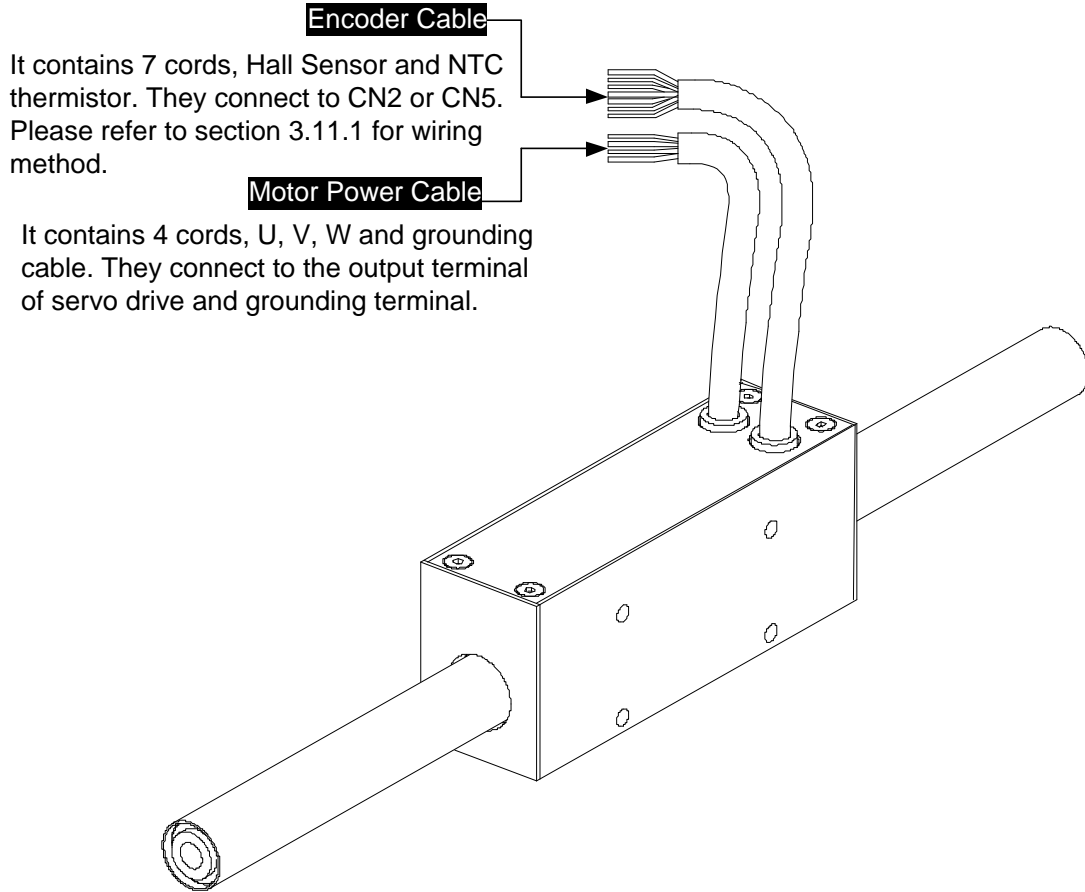

Motor Model	U · V · W / Definition	Color	AWG
ECML-S16□□□□□□S ECML-S20□□□□□□S	U	Red	20
	V	White	20
	W	Black	20
	CASE GROUND	Green	20
ECML-S25□□□□□□S ECML-S32□□□□□□S	U	Red	18
	V	White	18
	W	Black	18
	CASE GROUND	Green	18

Note:

- 1) U, V, W are the bare wire, which has no connector and terminal.
- 2) The total length of standard cable is 500mm.
- 3) The cover of the green grounding cable is heat-shrink tubing. If users cut off the grounding cable and re-connect it, please connect it to the shielded net for better noise separation.

Motor Model	Encoder Cable	Color	AWG
ECML-S16□□□□□□S ECML-S20□□□□□□S ECML-S25□□□□□□S ECML-S32□□□□□□S	Hall sensor 5V	Black	26
	Hall sensor 0V	Black / Red	26
	Hall sensor U	White	26
	Hall sensor V	Brown	26
	Hall sensor W	Blue	26
	Temperature signal +	Orange	26
	Temperature signal -	Orange / Red	26

Note:

- 1) U, V, W are the bare wire, which has no connector and terminal.
- 2) The total length of standard cable is 500mm. Please use shielded twisted-pair cable for encoder wiring so as to reduce the interference of noise.
- 3) The cover of the green grounding cable is heat-shrink tubing. If users cut off the grounding cable and re-connect it, please connect it to the shielded net. And the shielded net should firmly connect to SHIELD end  for better noise separation.
- 4) All signal cable of motor must connect to the servo drive.

3.11.3 Signal Converter Box

If you desire to connect Delta's servo drive to other brands of motor, ASD-IF-EN0A20 signal converter box is a great choice for you. It does not require external power-supply, driver or any complicated setting process.

Features and Functions:

- It can convert the square wave and sine wave to the communication signals which is exclusive use for Delta's servo system. It can be controlled by Delta's servo drive.
- After the signal is converted to high resolution signal, it can dramatically enhance the motor speed, provide precise position and control the speed limit so as to satisfy the demand of speed and precision.
It can fine-cut the sinusoid analog signal up to 2048 times, e.g. 20 μm pitch of single-phase sinusoid analog signal is outputted to linear scale, which can up to the resolution of $\frac{20}{2048} \mu m \approx 10nm$ via transition card.
- The original signal can be delivered to over 20 m without attenuation, which could ensure communication quality.
- Through the interpolation of sine wave signal, it could improve the resolution and avoid the limit of frequency so as to satisfy the demand of high-precision and high-speed for linear motor.

Installation

The product should be kept in the shipping carton before installation. In order to retain the warranty coverage, the product should be stored properly when it is not used for a period of time. Some storage suggestions are:

- Store in a clean and dry location.
- Store within an ambient temperature range of -20°C to +65°C (-4°F~149°F).
- Store within a relative humidity range of 0% to 90% and non-condensing.
- Do not store in a place subject to corrosive gases and liquids.
- Correctly packaged and place on a solid surface.
- Do not mount the production adjacent to heat-radiating elements, water, vapour, dust and oily dirt. The location should free from corrosive gases, liquids, airborne dust or metallic particles and no vibration and interference.

Model Name Explanation

<u>ASD</u>	-	<u>IF</u>	-	<u>EN</u>	<u>0A</u>	<u>20</u>	(1) Product	ASD: AC Servo Drive
(1)		(2)		(3)	(4)	(5)	(2) Product Name	IF: Interface
							(3) Module Type	EN: Encoder
							(4) Version Number	0A: Version Number
							(5) Specification of Connection Port	20: Connect to 20pin connector

Applicable Model

ASD-A2R-0121-□, ASD-A2R-0221-□, ASD-A2R-0421-□, ASD-A2R-1021-□,

ASD-A2R-1521-□, ASD-A2R-2023-□, ASD-A2R-3023-□, (□=F,L,M,U)

ASD-S-3023-F, ASD-S-4523-F, ASD-S-5523-F, ASD-S-7523-F

Appearance

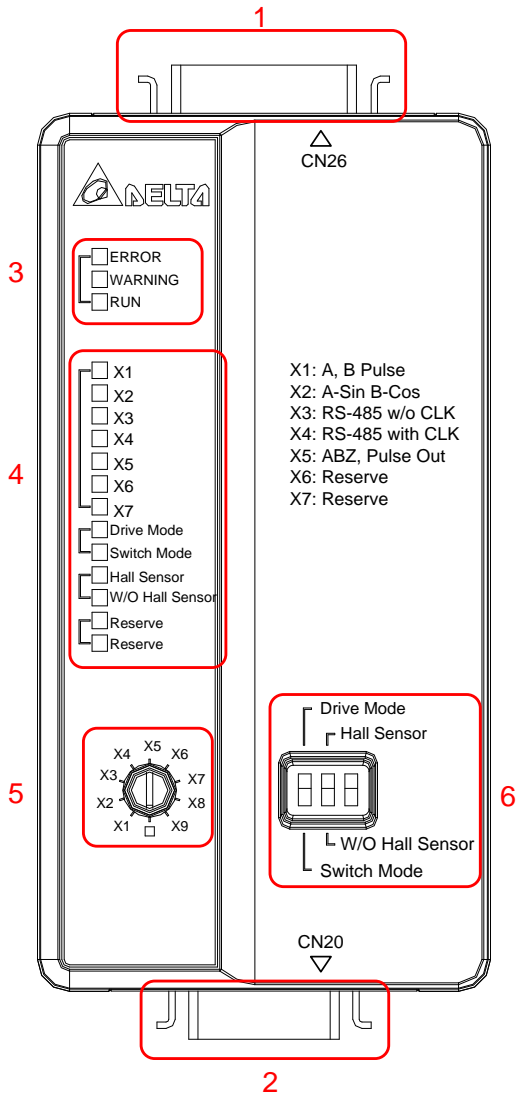

1. Signal source connector	CN26, 26 pin connector
2. Drive connector	CN20, 20 pin connector
3. Status indicators	ERROR: Error LED* WARNING: Warning LED* RUN: LED for normal operation
4. Function indicators	X1: Signal source is square digital signal X2: Signal source is sinusoidal analog signal X3~X5: Reserved X6~7: Reserved Drive Mode: Servo drive issues the command to control the status of converter box. The button and the switch do not work at the moment. Switch Mode: The status of converter box is controlled by the button and the switch. The command issued by servo drive does not work. Hall Sensor: Hall sensor is installed. W/O Hall Sensor: Hall sensor is not installed.
5. Signal switch	Use a flat screwdriver to rotate the switch. X1: Signal source is square digital signal X2: Signal source is sinusoidal analog signal X3~X9: Reserved
6. Function switch	Select the desired function by switching the switch up and down.

Note:

- 1) When an alarm occurs, the ERROR LED will light up and shows the alarm code on servo drive's LED display. Users could refer to troubleshooting section for alarm descriptions and corrective actions.
- 2) When a warning occurs, the WARNING LED will light up and shows the warning code on servo drive's LED display. Users could refer to troubleshooting section for alarm descriptions and corrective actions.

Specification

Item	ASD-IF-EN0A20
Power Supply	+5.0 V \pm 5%
Current Consumption	250 mA Typ. 500 mA Max.
Frequency Response	Analog signal: 500 kHz Max. Pulse signal: 2 MHz Max.
Analog Input Signal (Sin, Cos, Ref)	Differential Input Amplitude: 0.4 to 1.2 V _{p-p} Input Signal Level: 1.5 to 2.7 V
Pulse Input Signal	+5 V
Input Signal of Hall Sensor	+3.3 V
Output Signal	Position Data, Hall Sensor Information, Warning
Output Type	Serial data transmission
Weight	Approx. 70 g
Operation Temperature	0 ~ 55 °C
Storage Temperature	-20 ~+65 °C

Pin Definition

20 pin Connector

PIN	Definition	Descriptions	PIN	Definition	Descriptions
1	Reserved	-	11	/OZ	-
2	FPGA_TDI	-	12	FPGA_TRST	-
3	FPGA_TMS	-	13	GND	Power Ground
4	Drive_T-	Serial Communication Signal Transmission (-)	14	5VD	Power + 5 V
5	Drive_T+	Serial Communication Signal Transmission (+)	15	GND	Power Ground
6	FPGA_TCK	-	16	5VD	Power + 5 V
7	Reserved	-	17	OB	-
8	FPGA_TDO	-	18	/OB	-
9	OABZ_EN	Pulse Output Enabled	19	OA	-
10	OZ	-	20	/OA	-

26 pin Connector

PIN	Definition	Descriptions	PIN	Definition	Descriptions
1	QEA_IN+	A-phase (+) pulse input	14	AGND	Sinusoid Power Ground
2	QEA_IN-	A-phase (-) pulse input	15	Motor_Temp	-
3	QEB_IN+	B-phase (+) pulse input	16	HALL_W	W-phase Hall Sensor Signal Input

4	QEB_IN-	B-phase (-) pulse input	17	HALL_V	V-phase Hall Sensor Signal Input
5	QEZ_IN+	Z-phase (+) pulse input	18	HALL_U	U-phase Hall Sensor Signal Input
6	QEZ_IN-	Z-phase (-) pulse input	19	LiMot_CLK-	-
7	QES_IN-	-	20	LiMot_CLK+	-
8	A+_IN	Sinusoid A-phase (+) input	21	LiMot_Data-	-
9	A-_IN	Sinusoid A-phase (-) input	22	LiMot_Data+	-
10	B+_IN	Sinusoid B-phase (+) input	23	GND	Pulse Power Ground
11	B-_IN	Sinusoid B-phase (-) input	24	GND	Pulse Power Ground
12	R+_IN	Sinusoid Z-phase (+) input	25	5VD	Power + 5 V
13	R-_IN	Sinusoid Z-phase (-) input	26	5VD	Power + 5 V

Installation

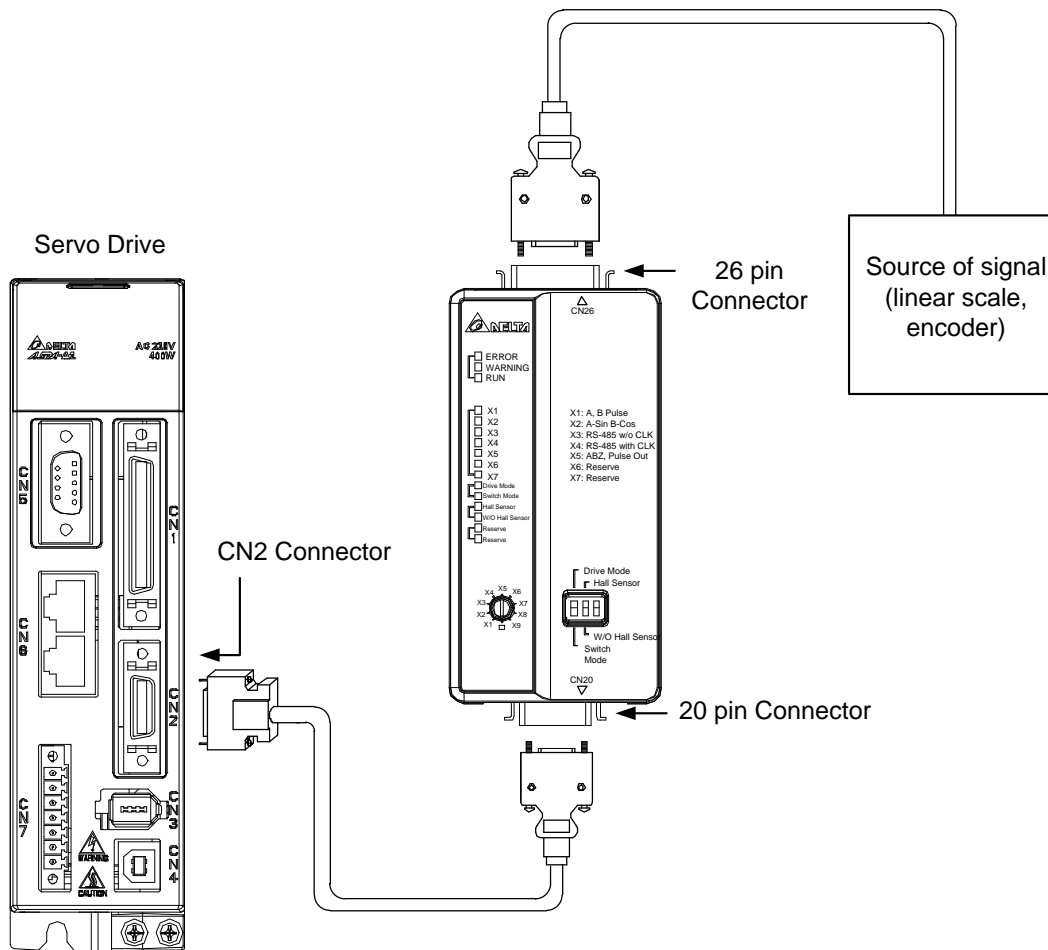

Note: the above diagram is not drawn in equal proportion. It is for describing the connection only.

Chapter 4 Panel Display and Operation

This chapter details the panel status and operation of ADSA-A2R series servo drive.

4.1 Panel Description

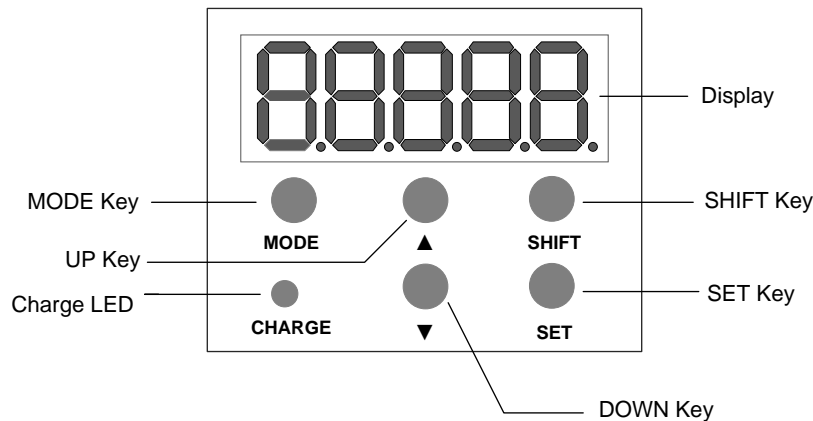

Name	Function
Display	Five-/Seven-segment display is for displaying the monitoring values, parameter values and setting values.
SHIFT Key	Pressing SHIFT key can scrolls through parameter groups. After a parameter is selected and its value displayed, pressing SHIFT key can move the cursor to the left and then change parameter settings by using arrow keys.
SET Key	Pressing the SET key can display and save the parameter groups, the various parameter settings. In monitor mode, pressing SET key can switch decimal or hexadecimal display. In parameter mode, pressing SET key can enter into parameter setting mode.
DOWN Key	Pressing the DOWN key can scroll through and change monitor codes, parameter groups and various parameter settings.
MODE Key	Pressing MODE key can enter or exit different parameter groups, and switch between Monitor mode and Parameter mode.
UP Key	Pressing the UP key can scroll through and change monitor codes, parameter groups and various parameter settings.
Charge LED	The Charge LED lights to indicate the power is applied to the circuit.

4.2 Parameter Setting Procedure

Switch the mode:

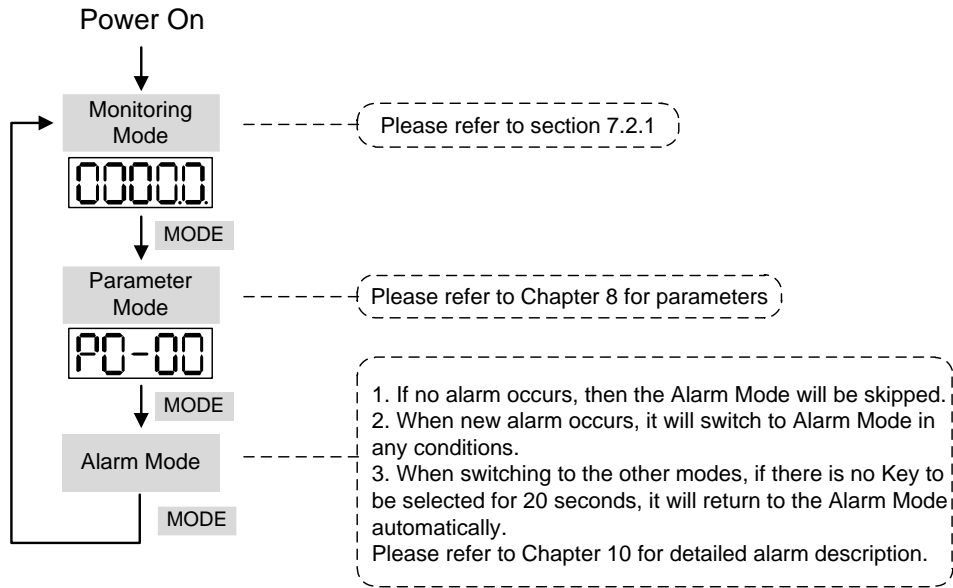

Operate in each mode:

Monitoring mode

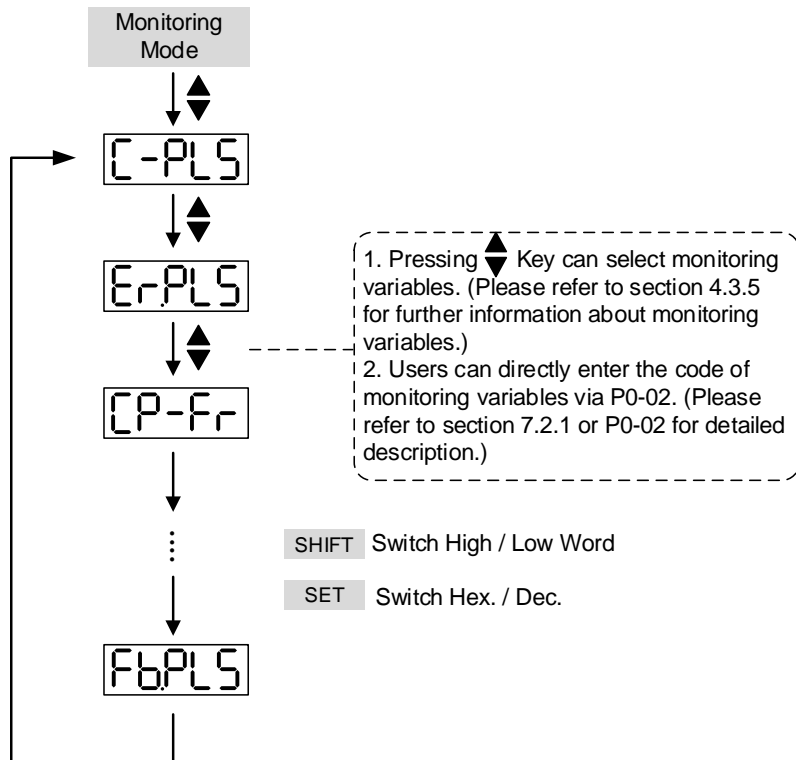

Parameter Mode

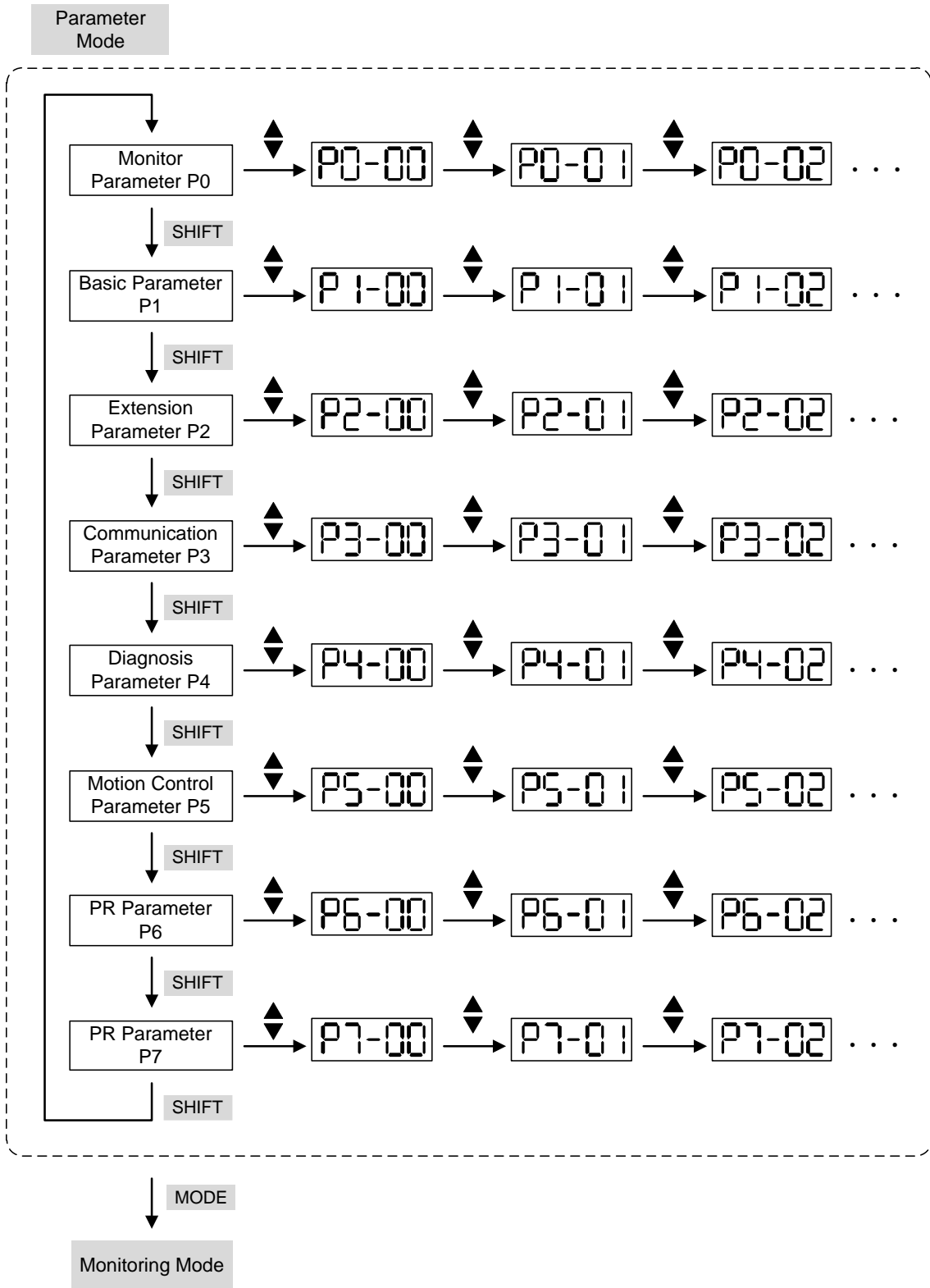

Edit Setting Mode

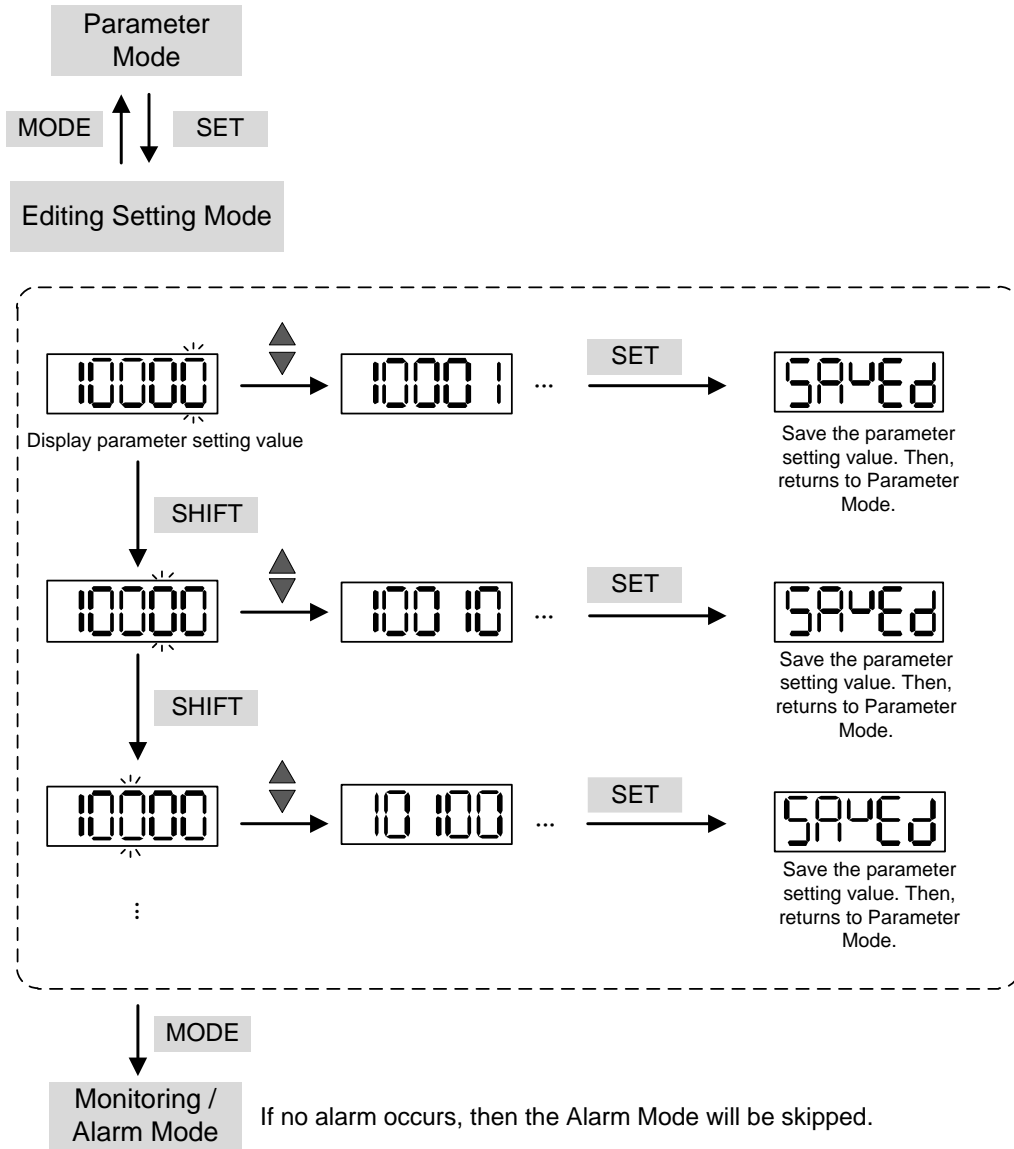

4.3 Status Display

4.3.1 Setting Saved Display

When finishing editing parameter, press the SET Key to save the setting. The panel will display the setting status according to the setting for a second.

Displayed Symbol	Description
	The setting value is saved correctly. (Saved)
	Read-only parameter. Write-protected. (Read-Only)
	Enter the wrong password or no password has been entered. (Locked)
	Incorrect setting value or enter the reserved setting value. (Out of Range)
	No entering is allowed when it is Servo ON. (Servo On)
	Parameter will be effective after the servo drive is re-power on. (Power On)

4.3.2 Decimal Point

Displayed Symbol	Description
	<p>High byte / low byte indication: When the data is displayed in decimal 32 bits, it is for indicating the current high or low byte.</p> <p>Negative sign: When the data is displayed in decimal format, the two decimal points in the left represents the negative sign, no matter it is showed in 16 or 32 bits. When it is showed in hexadecimal format, it only shows positive sign.</p>

4.3.3 Alarm Message

Displayed Symbol	Description
	<p>When there is an error of the drive, it will show 'AL' as the alarm sign and 'nnn' as the alarm code.</p> <p>For further explanation, please refer to Chapter 8, P0-01, parameter description, or Chapter 10, Troubleshooting.</p>







4.3.4 Positive and Negative Sign Setting



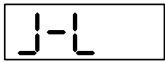
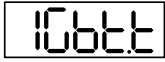

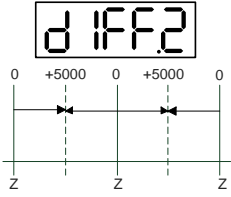

Displayed Symbol	Description
	When entering into the Editing Setting Mode, pressing UP / DOWN Key can increase or decrease the displayed content. The SHIFT Key can change the desired adjusted carry value. (The carry value is blinking at the moment.)
	Pressing the SHIFT Key for two seconds can switch the positive (+) and negative (-) sign. If the parameter is over the range after switching the positive or negative sign, then it cannot be switched.

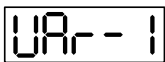
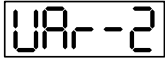
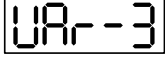
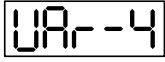
4.3.5 Monitor Display

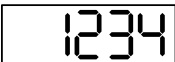
When the drive is applied to the power, the display will show the monitor displayed symbol for a second, and then enter into the Monitor Mode. In Monitor Mode, the UP / DOWN Key can change the desired monitor variable. Or, the user can directly change parameter P0-02 to set the monitor code. When applying to the power, the system will pre-set the monitor code according to the setting value of P0-02. For example, the setting value of P0-02 is 4. Every time when applying to the power, it will display C-PLS monitor sign first, and then shows the input pulse number of pulse command.

P0-02 Setting Value	Monitor Displayed Symbol	Description	Unit
0	FbPUU	Motor feedback pulse number (after the scaling of electronic gear ratio) (User unit)	[user unit]
1	C-PUU	Input pulse number of pulse command (after the scaling of electronic gear ratio) (User unit)	[user unit]
2	ErPUU	The difference of error pulse number between control command pulse and feedback pulse number (User unit)	[user unit]
3	FbPLS	Motor feedback pulse number (encoder unit) (Resolution of single-phase pulse; 1.28 millions Pulse/rev for Delta 20 bit rotary motor)	[pulse]
4	C-PLS	Input pulse number of pulse command (before the scaling of electronic gear ratio) (encoder unit)	[pulse]
5	ErPLS	Error pulse number (after the scaling of electronic gear ratio) (encoder unit)	[pulse]
6	CP-Fr	Input frequency of pulse command	[Kpps]
7	SPEED	Motor speed	Rotary motor [r/min] Linear motor [m/s]
8	CSPd1	Speed input command	[Volt]
9	CSPd2	Speed input command	[r/min]
10	C-tq1	Torque input command	[Volt]
11	C-tq2	Torque input command	[%]
12	AUG-L	Average torque	[%]
13	PE-L	Peak torque	[%]
14	U bus	Main circuit voltage	[Volt]

P0-02 Setting Value	Monitor Displayed Symbol	Description	Unit
15		Rotary motor: Load / Motor inertia ratio Linear motor: Load / Weight of movable section and load (Note: If it shows 130, it means the actual inertia is 13.0 and the actual weight is 13kg)	Rotary motor [0.1times] Linear motor [0.1Kg]
16		IGBT temperature	[°C]
17		Resonance frequency (Low byte is the first resonance and high byte is the second one).	[Hz]
18		The absolute pulse number of encoder Z phase equals to the homing value, 0. It will be +5000 or -5000 pulse when rotating in forward or reverse direction.	-
19		Mapping parameter #1: shows the content of parameter P0-25 (specify the mapping target by P0-35)	-
20		Mapping parameter #2: shows the content of parameter P0-26 (specify the mapping target by P0-36)	-
21		Mapping parameter #3: shows the content of parameter P0-27 (specify the mapping target by P0-37)	-
22		Mapping parameter #4: shows the content of parameter P0-28 (specify the mapping target by P0-38)	-
23		Monitor variable #1: shows the content of parameter P0-09 (specify the monitor variable code by P0-17)	-
24		Monitor variable #2: shows the content of parameter P0-10 (specify the monitor variable code by P0-18)	-
25		Monitor variable #3: shows the content of parameter P0-11 (specify the monitor variable code by P0-19)	-
26		Monitor variable #4: shows the content of parameter P0-12 (specify the monitor variable code by P0-20)	-

Example of the displayed value	Status Description	
 (Dec)	16 bits	If the value is 1234, it displays 01234 (shows in decimal format).
 (Hex)		If the value is 0x1234, it displays 1234 (shows in hexadecimal format; the first digit does not show any).
 (Dec high)	32 bits	If the value is 1234567890, the display of the high byte is 1234.5 and displays 67890 as the low byte (shows in decimal format).
 (Dec low)		
 (Hex high)		If the value is 0x12345678, the display of the high byte is h1234 and displays L5678 as the low byte (shows in hexadecimal format).
 (Hex low)		
	Negative display. If the value is -12345, it displays 1.2.345 (only shows in decimal format; there is no positive or negative sign for hexadecimal format display).	

Note:

- 1) Dec means it is displayed in decimal format. Hex means it is displayed in hexadecimal format.
- 2) The above display methods can be applied in Monitor Mode and Editing Setting Mode.
- 3) When all monitor variable is 32 bits, high / low bit and the display (Dec/Hex) can be switched. According to the definition in Chapter 8, each parameter only supports one displaying method and cannot be switched.

4.4 General Function

4.4.1 Operation of Fault Record Display

When it is in Parameter Mode, select P4-00~P4-04 and press the SET Key, the corresponding fault record will be shown.

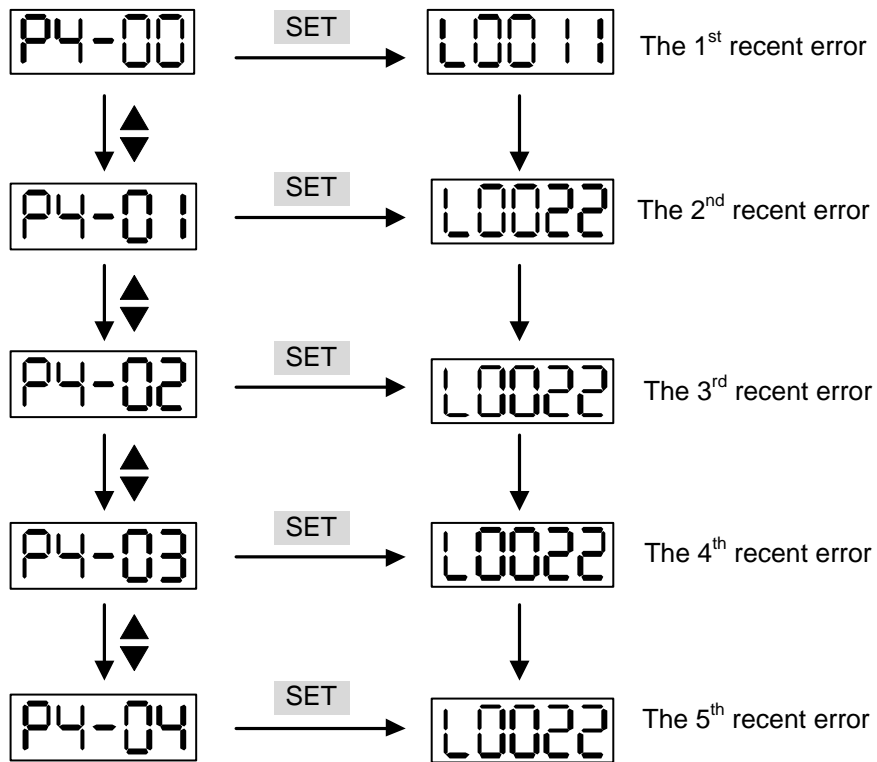

4.4.2 JOG Mode

When it is in Parameter Mode, select P4-05 and follow the setting method below for JOG operation.

- (1) Press the SET Key to display the speed value of JOG. The default value is 20r/min. (Unit: rotary motor [r/min]; linear motor [10^{-3} m/s])
- (2) Press UP or DOWN Key to adjust the desired speed value of JOG. It is adjusted to 100r/min in the example. (Unit: rotary motor [r/min]; linear motor [10^{-3} m/s])
- (3) Press the SET Key to display JOG and enter JOG mode.
- (4) When it is in JOG Mode, press UP or DOWN Key to enable the servo motor in forward or reverse direction. The servo motor stops running as soon as the user stops pressing the key. JOG operation is working only when it is Servo ON.

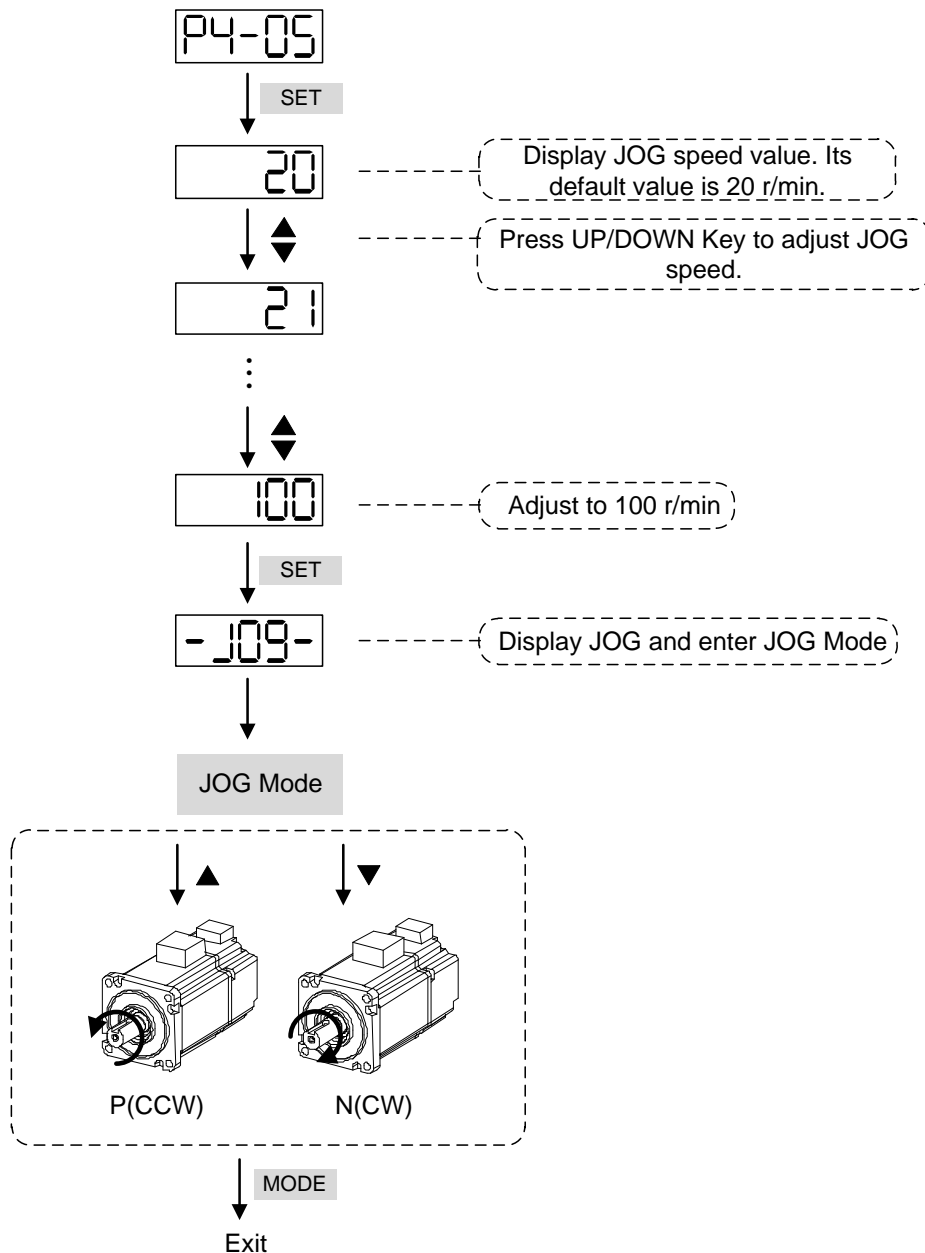

4.4.3 Force DO Output

Enter into the Output Diagnosis Mode by the following settings. Set P2-08 to 406 and enable the function of force DO output. Then, set the force DO output by binary method via P4-06. When the setting value is 2, DO2 will be forced to enable. When the setting value is 5, DO1 and DO3 will be forced to enable. No data is retained in this mode. It returns to the normal DO mode when re-power on the drive or set P2-08 to 400.

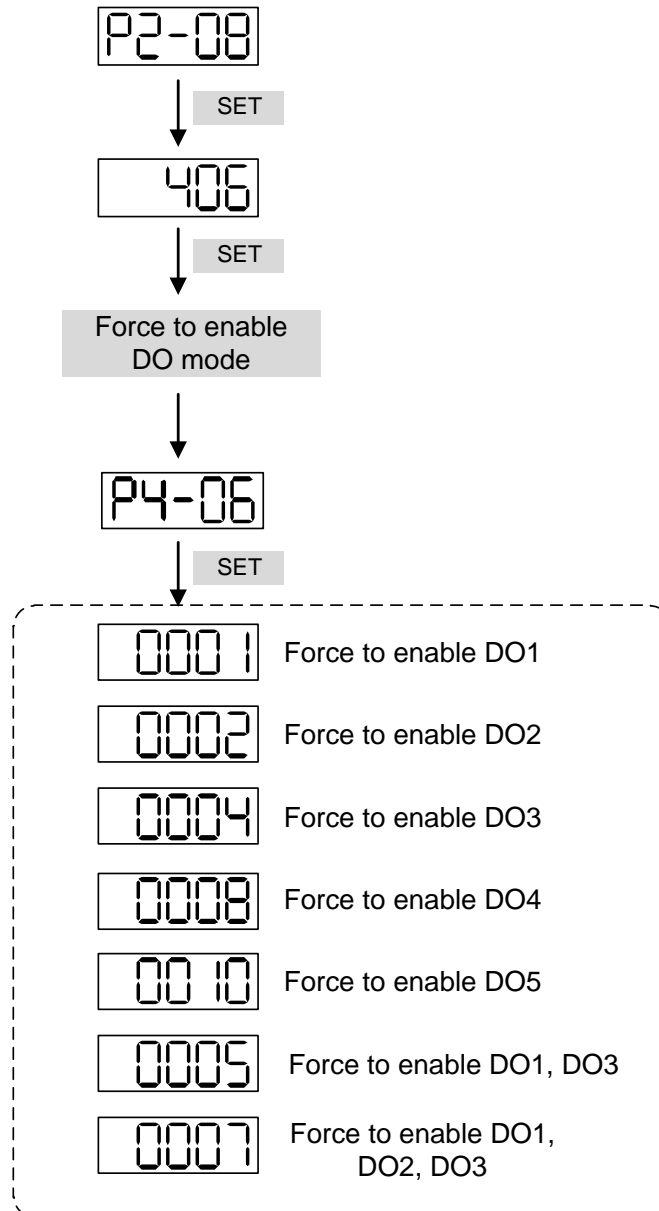

Note: P4-06 is displayed in hexadecimal format. Therefore, it will not show the fifth 0.

4.4.4 Digital Input Diagnosis Operation

Enter into the Digital Input Diagnosis Mode by the following setting methods. When the external output signal DI1~DI8 is ON, the corresponding signal will be shown on the panel. It is displayed by bit. When it shows bit, it means it is ON.

For example, if it shows **3FE1**, **E** is in hexadecimal format, it will be **1100** when it transfers to binary format. Then, DI6~DI8 is ON.

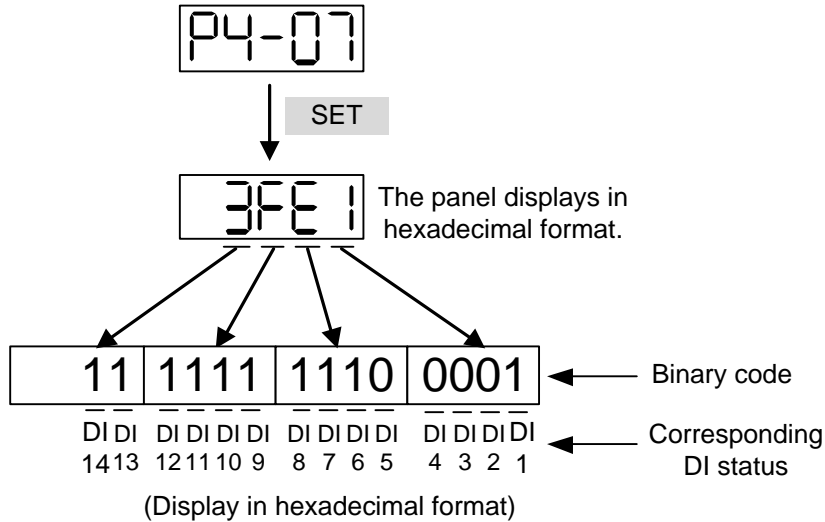

4.4.5 Digital Output Diagnosis Operation

Enter into the Digital Output Diagnosis Mode by the following setting methods. The output signal DO1~DO5 is ON and the corresponding signal will be shown on the panel. It is displayed by bit. When it shows bit, it means it is ON.

For example, if it shows **1F**, **F** is in hexadecimal format, it will be **1111** when it transfers to binary format. Then, DO1~DO4 is ON.

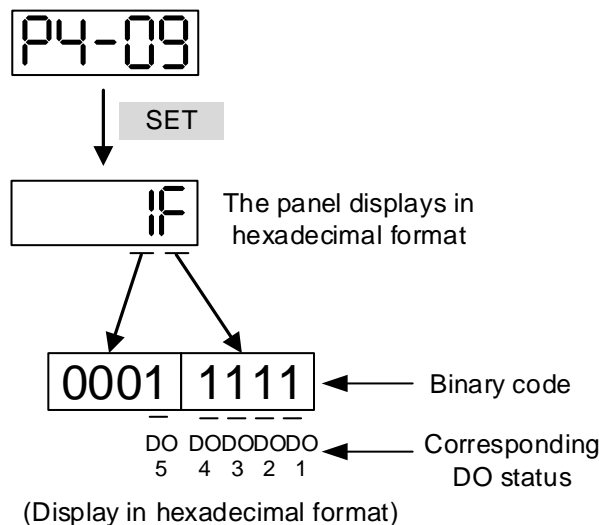

Chapter 5 Trial Operation and Tuning

This chapter is divided into two parts to describe the trial operation. The first one is the inspection without load and another one is the inspection with load. For safety reasons, please conduct the first inspection.

5.1 Inspection without Load

Please remove the load of the servo motor, including coupling on the shaft and accessories so as to avoid any damage on servo drive or mechanism. This is aiming to avoid the falling off of the disassembled parts of the motor shaft and indirectly causing the personnel injury or equipment damage during operation. Running the motor without load, if the servo motor can run during normal operation, then it can connect to load for operation.

Caution: Please operate the servo motor without load first. If the servo motor runs normally, connect the load afterwards in order to avoid any danger.

Please check the following items before operation.

<p>Inspection before operation (has not applied to the power yet)</p>	<ul style="list-style-type: none"> ■ Check if there is any obvious damage shown on its appearance. ■ The splicing parts of the wiring terminal should be isolated. ■ Make sure the wiring is correct so as to avoid the damage or any abnormality. ■ Check if the electric conductivity objects including sheet metal (such as screws) or inflammable objects are not inside the servo drive. ■ Check if the control switch is in OFF status. ■ Do not place the servo drive or external regenerative resistor on inflammable objects. ■ To avoid the electromagnetic brake losing efficacy, please check if stop function and circuit break function can work normally. ■ If the peripheral devices are interfered by the electronic instruments, please reduce electromagnetic interference with devices. ■ Please make sure the external voltage level of the servo drive is correct. ■ When connecting other brand of rotary motor, please setup motor parameters before operation. Please refer to the Chapter of Motor Parameter Setting.
<p>Inspection before running the servo drive (has already applied to the power)</p>	<ul style="list-style-type: none"> ■ The encoder cable should avoid excessive stress. When the motor is running, make sure the cable is not frayed or over extended. ■ Please contact with Delta if there is any vibration of the servo motor or unusual noise during the operation. ■ Make sure the setting of the parameters is correct. Different

	<p>machinery has different characteristic, please adjust the parameter according to the characteristic of each machinery.</p> <ul style="list-style-type: none"> ■ Please reset the parameter when the servo drive is in SERVO OFF status, or it may cause malfunction. ■ When the relay is operating, make sure it can work properly. ■ Check if the power indicator and LED display works normally.
--	--

5.2 Apply Power to the Servo Drive

Please follow the instructions below.

A. Make sure the wiring between the motor and servo drive is correct.

- 1) When connecting to Delta's 20bit rotary motor, U, V, W and FG have to connect to cable red, white, black and green respectively. If the wiring is incorrect, the motor cannot work normally. If connecting to other brand of 20bit rotary motor, the new function, Motor Auto Detection (Please refer to Chapter 12) can help to check and correct the problem of wrong wiring. The ground wire FG of the motor must be connected to the ground terminal of the servo drive. Please refer to Chapter 3.1 for wiring.
- 2) The encoder cable of the motor has correctly connected: If users only desire to execute JOG function, it is unnecessary to connect CN1 and CN3 (Please refer to Chapter 5.3). Refer to Chapter 3.1 and 3.5 for the wiring of encoder.

Caution: Do not connect the power terminal (R, S, T) to the output terminal (U, V, W) of the servo drive. Or it might damage the servo drive.

B. Power circuit of the servo drive:

Apply power to the servo drive. Please refer to Chapter 3.1.3 for power wiring.

C. Power on:

Power of the servo drive: including control circuit (L1c, L2c) and main circuit (R, S, T) power.

When the power is on, the display of the servo drive will be:

AL014

The digital input (DI6~DI8) of the default value is the signal of reverse limit error (NL), forward limit error (PL) and emergency stop (EMGS), if not using the default setting of DI6~DI8, adjusting the setting of P2-15~P2-17 is a must. Parameters could be set to 0 (disable this DI function) or modified to another function.

From the last setting, the servo drive status displays parameter P0-02 setting as the motor speed (06), then the screen display will be:

SPEED
↓
00000

When the screen displays no text, please check if the power of control circuit is under voltage.

1) When the screen displays

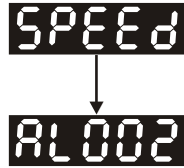

Warning of overvoltage:

It means the voltage input by the main circuit is higher than the rated voltage or power input error (incorrect power system).

Corrective action:

- Use the voltmeter to measure if the input voltage from the main circuit is within the range of rated voltage value.
- Use the voltmeter to measure if the power system complies with the specification.

2) When the screen displays

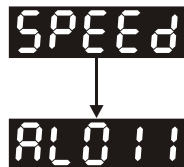

Warning of encoder error:

Check if the motor encoder is securely connected or the wiring is correct.

Corrective action:

- Check if the wiring is the same as the instruction of the user manual.
- Check the encoder connector.
- Check if the wiring is loose.
- Encoder is damaged.

3) When the screen displays

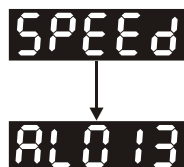

Warning of emergency stop:

Please check if any of the digital input DI1~DI8 is set to emergency stop (EMGS).

Corrective action:

- If not desire to set emergency stop (EMGS) as one of the digital input, make sure no digital input is set to emergency stop (EMGS) among DI1~DI8. (That is to say none of the parameters, P2-10~P2-17 is set to 21.)
- If the signal of emergency stop (EMGS) is needed, make sure one of the digital input, DI1~DI8, is set to emergency stop (EMGS) and that DI has to be ON.

4) When the screen displays

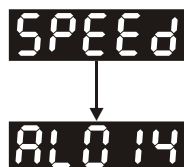

Warning of negative limit error:

Please check if any of the digital input DI1~DI8 is set to negative limit (NL) and that DI is ON.

Corrective action:

- If not desire to set negative limit (NL) as one of the digital input, make sure no digital input is set to negative limit (NL) among DI1~DI8. (That is to say none of the parameters, P2-10~P2-15 is set to 22.)
- If the signal of negative limit (NL) is needed, make sure one of the digital input, DI1~DI8, is set to negative limit (NL) and that DI has to be ON.

5) When the screen displays

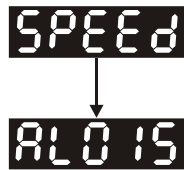

Warning of positive limit error:

Please check if any of the digital input DI1~DI8 is set positive limit (PL) and that DI is ON.

Corrective action:

- If not desire to set positive limit (PL) as one of the digital input, make sure no digital input is set to positive limit (PL) among DI1~DI8. (That is to say none of the parameters, P2-10~P2-17 is set to 23.)
- If the signal of positive limit (PL) is needed, make sure one of the digital input, DI1~DI8, is set to positive limit (PL) and that DI has to be ON.

6) When the screen displays



Warning of overcurrent:

Corrective action:

- Check the connection between the motor and servo drive.
- Check if the conducting wire is short circuited.

Exclude short circuit and avoid metal conductors being exposed.

7) When the screen displays



Warning of under voltage:

Corrective action:

- Check if the wiring of main circuit input voltage is correct.
- Use voltmeter to measure if the main circuit voltage is normal.
- Use voltmeter to measure if the power system complies with the specification.

Note: During the process of power on or servo on, if an alarm occurs or shows any abnormal display, please contact the distributors.

5.3 JOG Trial Run without Load

It is very convenient to test the motor and servo drive with the method of JOG trial run without load since the extra wiring is unnecessary. For safety reasons, it is recommended to set JOG at low speed. Please see the following descriptions.

STEP 1: Use software setting to Servo ON. Set parameter P2-30 to 1. This setting is to force the servo ON through software.

STEP 2: Set P4-05 as JOG speed (Unit: rotary motor [r/min]; linear motor [10^{-3} m/s]). After setting the desired JOG speed, press the **SET** Key, the servo drive will enter JOG mode.

STEP 3: Press the **MODE** Key to exist JOG mode.

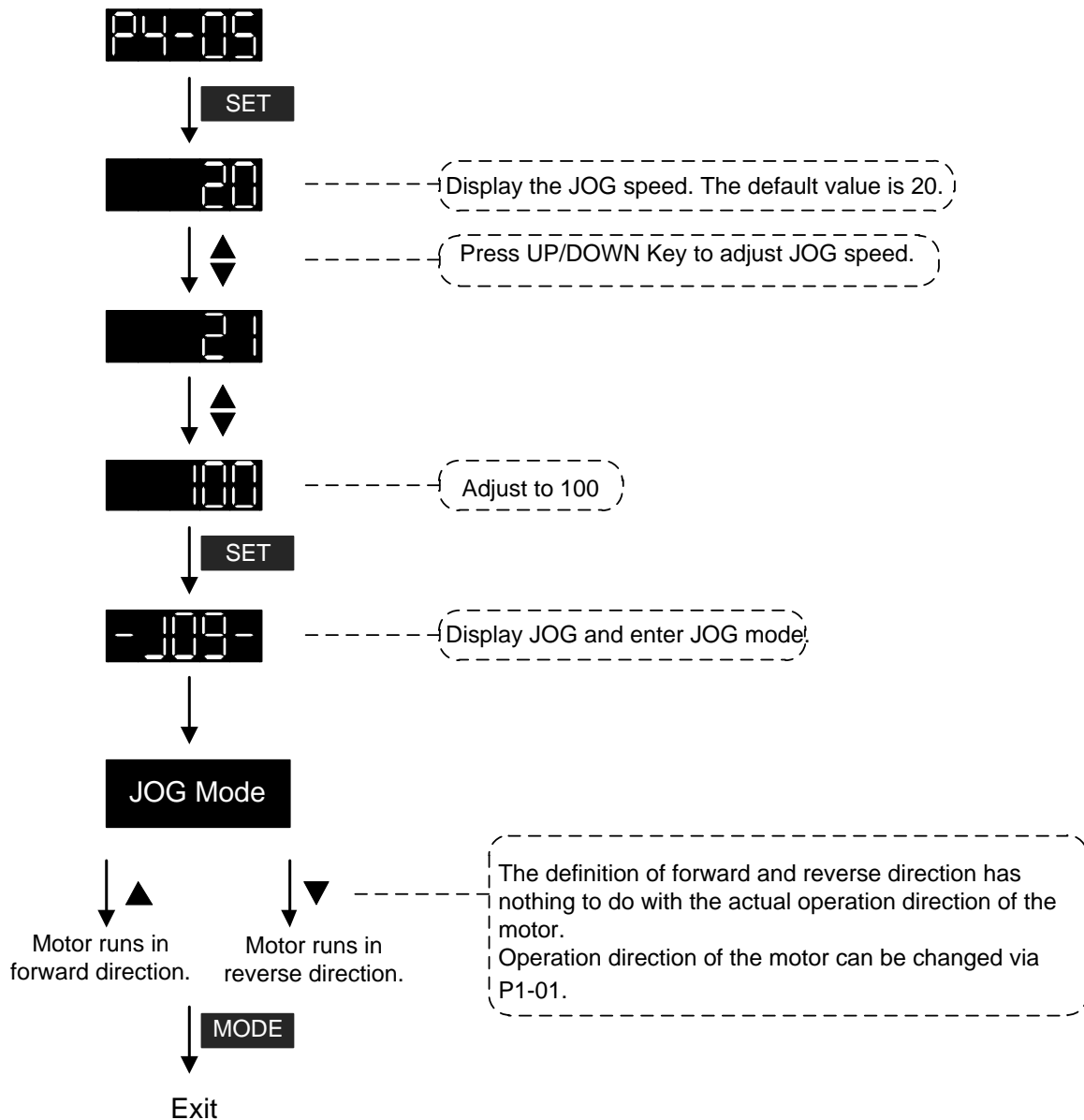

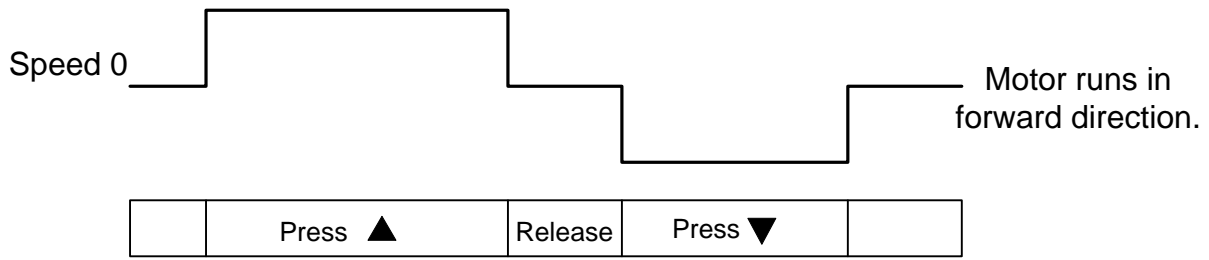

If the motor does not run, please check if the wiring between UVW and encoder cable is correct.
 If the motor runs abnormally, please check if the UVW phase sequence is correct.

5.4 Trial Run without Load (Speed Mode)

Before the trial run without load, firmly secure the motor base so as to avoid the danger cause by the reaction of motor operation.

STEP 1:

Set the control mode of the servo drive to speed mode. Set P1-01 to 2. Then, re-power on the servo drive.

STEP 2:

In speed control mode, the digital input settings of trial run are as follows:

Digital Input	Parameter Setting Value	Symbol	Function Description	CN1 Pin No
DI1	P2-10 = 101	SON	Servo ON	DI1- = 9
DI2	P2-11 = 109	TRQLM	Torque limit	DI2- = 10
DI3	P2-12 = 114	SPD0	Speed command selection	DI3- = 34
DI4	P2-13 = 115	SPD1	Speed command selection	DI4- = 8
DI5	P2-14 = 102	ARST	Alarm reset	DI5- = 33
DI6	P2-15 = 0	Disabled	Invalid DI function	-
DI7	P2-16 = 0	Disabled	Invalid DI function	-
DI8	P2-17 = 0	Disabled	Invalid DI function	-
EDI9	P2-36 = 0	Disabled	Invalid DI function	CN7 = 2
EDI10	P2-37 = 0	Disabled	Invalid DI function	CN7 = 3
EDI11	P2-38 = 0	Disabled	Invalid DI function	CN7 = 4
EDI12	P2-39 = 0	Disabled	Invalid DI function	CN7 = 5
EDI13	P2-40 = 0	Disabled	Invalid DI function	CN7 = 6
EDI14	P2-41 = 0	Disabled	Invalid DI function	CN7 = 7

The above table disables the function of negative limit (DI6), positive limit (DI7) and emergency stop (DI8). Thus, the value of parameter P2-15 ~ P2-17 is set to 0 (Disabled).

The digital input of Delta' s servo drive can be programmed by users. When programming digital input, please refer to the description of DI code.

The default setting includes the function of negative limit, positive limit and emergency stop, therefore, after the setting is completed, if there is any alarm occurs, please re-power on the servo drive or switch ON DI5 to clear the alarm. Please refer to Chapter 5.2.

The speed command selection is determined by SPD0 and SPD1. See the table below.

Speed Command No.	DI signal of CN1		Command Source	Content	Range
	SPD1	SPD0			
S1	0	0	External analog command	Voltage deviation between V-REF and GND	-10V ~ +10V
S2	0	1	Register parameter	P1-09	-60000 ~ 60000
S3	1	0		P1-10	-60000 ~ 60000
S4	1	1		P1-11	-60000 ~ 60000

0: means DI is OFF

1: means DI is ON

Register parameter

Permanent magnet synchronous rotary motor is -60000 ~ 60000; Setting value = setting range x unit (0.1r/min).

Permanent magnet synchronous linear motor is -15999999 ~ 15999999; Setting value = setting range $\times 10^{-6} m/s$.

For example: P1-09 = +30000; the setting value of permanent magnet synchronous rotary motor is $+30000 \times 0.1r/min = +3000r/min$.

The setting value of permanent magnet synchronous linear motor = $+30000 \times 10^{-6} m/s = 0.03m/s$.

For example: P1-09 = +30000; Setting value = $+30000 \times 0.1r/min = +3000r/min$

Command setting of speed register (Take rotary motor as the example)

Set parameter P1-09 to 30000.	Input command	Rotation direction
Set parameter P1-10 to 1000.	+	CW
Set parameter P1-11 to -30000.	-	CCW

STEP 3 :

- (1) Users switch ON DI1 and Servo ON.
- (2) Both DI3 (SPD0) and DI4 (SPD1), the speed command, are OFF, which means it currently executes S1 command. The motor rotates according to analog voltage command.
- (3) When DI3 (SPD0) is ON, it means it currently executes S2 command (3000r/min). The speed is 3000r/min at the moment.
- (4) When DI4 (SPD1) is ON, it means it currently executes S3 command (100r/min). The speed is 100r/min.
- (5) When both DI3 (SPD0) and DI4 (SPD1) are ON, it means S4 command (-3000r/min) is executed at the moment. The speed is -3000r/min.
- (6) Step (3), (4) and (5) can be repeatedly executed.
- (7) If users desire to stop the motor, switch OFF DI1 (Servo OFF).

5.5 Trial Run without Load (Position Mode)

Before the trial run without load, firmly secure the motor base so as to avoid the danger cause by the reaction of motor operation.

STEP 1:

Set the control mode of the servo drive to position mode.

Set parameter P1-01 to 1, which is the position mode. Then, re-power on the servo drive.

STEP 2: In position mode, the digital input settings of trial run are as follows:

Digital Input	Parameter Setting Value	Symbol	Function Description	CN1 Pin No
DI1	P2-10 = 101	SON	Servo ON	DI1- = 9
DI2	P2-11 = 108	CTRG	Torque limit	DI2- = 10
DI3	P2-12 = 111	POS0	Position command selection	DI3- = 34
DI4	P2-13 = 112	POS1	Position command selection	DI4- = 8
DI5	P2-14 = 102	ARST	Alarm reset	DI5- = 33
DI6	P2-15 = 0	Disabled	Invalid DI function	-
DI7	P2-16 = 0	Disabled	Invalid DI function	-
DI8	P2-17 = 0	Disabled	Invalid DI function	-
EDI9	P2-36 = 0	Disabled	Invalid DI function	CN7 = 2
EDI10	P2-37 = 0	Disabled	Invalid DI function	CN7 = 3
EDI11	P2-38 = 0	Disabled	Invalid DI function	CN7 = 4
EDI12	P2-39 = 0	Disabled	Invalid DI function	CN7 = 5
EDI13	P2-40 = 0	Disabled	Invalid DI function	CN7 = 6
EDI14	P2-41 = 0	Disabled	Invalid DI function	CN7 = 7

The above table disables the function of negative limit (DI6), positive limit (DI7) and emergency stop (DI8), thus, set P2-15 ~ P2-17 and P2-36 ~ P2-41 to 0 (Disabled). The digital input of Delta' s servo drive can be programmed by users. When programming digital input, please refer to the description of DI code.

The default setting includes the function of negative limit, positive limit and emergency stop, therefore, after the setting is completed, if there is any alarm occurs, please re-power on the servo drive or switch ON DI5 to clear the alarm. Please refer to Chapter 5.2.

Please refer to Chapter 3.10.2, Position (PR) Mode Standard Wiring for wiring diagram. However, since POS2 is not the default digital input, set P2-14 to 113. Please refer to the table below for 64 sets of register command, POS0~POS5 and the relative parameters.

Position Command	POS5	POS4	POS3	POS2	POS1	POS0	CTRG	Corresponding Parameter
P1	0	0	0	0	0	0	↑	P6-00
								P6-01
P2	0	0	0	0	0	1	↑	P6-02
								P6-03
~								~
P50	1	1	0	0	1	0	↑	P6-98
								P6-99
P51	1	1	0	0	1	1	↑	P7-00
								P7-01
~								~
P64	1	1	1	1	1	1	↑	P7-26
								P7-27

















0: means DI is OFF

1: means DI is ON

Users can set the 64-set of command value (P6-00~P7-27). The value can be set as the absolute position command.

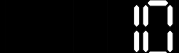
5.6 Tuning Procedure

Inertia ratio of rotary motor / Total weight estimation (kg) of linear motor and load ---- JOG mode

1. After completing wiring, when applying to the power, the servo drive will display:	
2. Press the MODE Key to select the mode of parameter function.	
3. Press the SHIFT Key twice to select the mode of parameter group.	
4. Press the UP Key to select parameter P2-17.	
5. Press the SET Key to display parameter value, which is shown as the content on the right.	
6. Press the SHIFT Key twice, then press the UP Key and then press the SET Key.	
7. Press the UP Key to select parameter P2-30.	
8. Press the SET Key to display the parameter value.	
9. Press the UP Key and select the parameter value 1.	
10. Press the SET Key. The panel will display P2-30 as shown on the right.	
11. Press the MODE Key and then press the DOWN Key to select the value of inertia ratio.	
12. The panel displays the current value of inertia ratio / total weight of movable section and load (kg) (default value).	
13. Press the MODE Key to select the mode of parameter function.	
14. Press the SHIFT Key twice to select the mode of parameter group.	
15. Press the UP Key twice to select parameter P4-05.	
16. Press the SET Key to show the content, which is 20r/min at JOG speed. Press the UP or DOWN Key to increase or decrease the JOG speed. Press the SHIFT Key to move to the next digit of the left. (Unit: rotary motor [r/min]; linear motor [10^{-3} m/s])	
17. Set the desired JOG speed and press the SET Key which is shown as the figure on the right.	
18. Press the UP Key to rotate the motor in forward direction while press the DOWN Key the motor will rotate in reverse direction.	
19. Execute JOG operation at low speed first. With the constant speed, if the motor operates smoothly in forward and reverse direction, users can execute JOG operation at higher speed.	
20. In P4-05, the servo drive cannot display inertia ratio. Please press the MODE Key twice to view the value of inertia ratio. If users desire to execute JOG operation again, press the MODE Key, and then press the SET Key twice. Observe the panel display to see if the load inertia ratio / total weight of movable section and load remain at the same value after acceleration and deceleration.	

5.6.1 Flowchart of Tuning Procedure

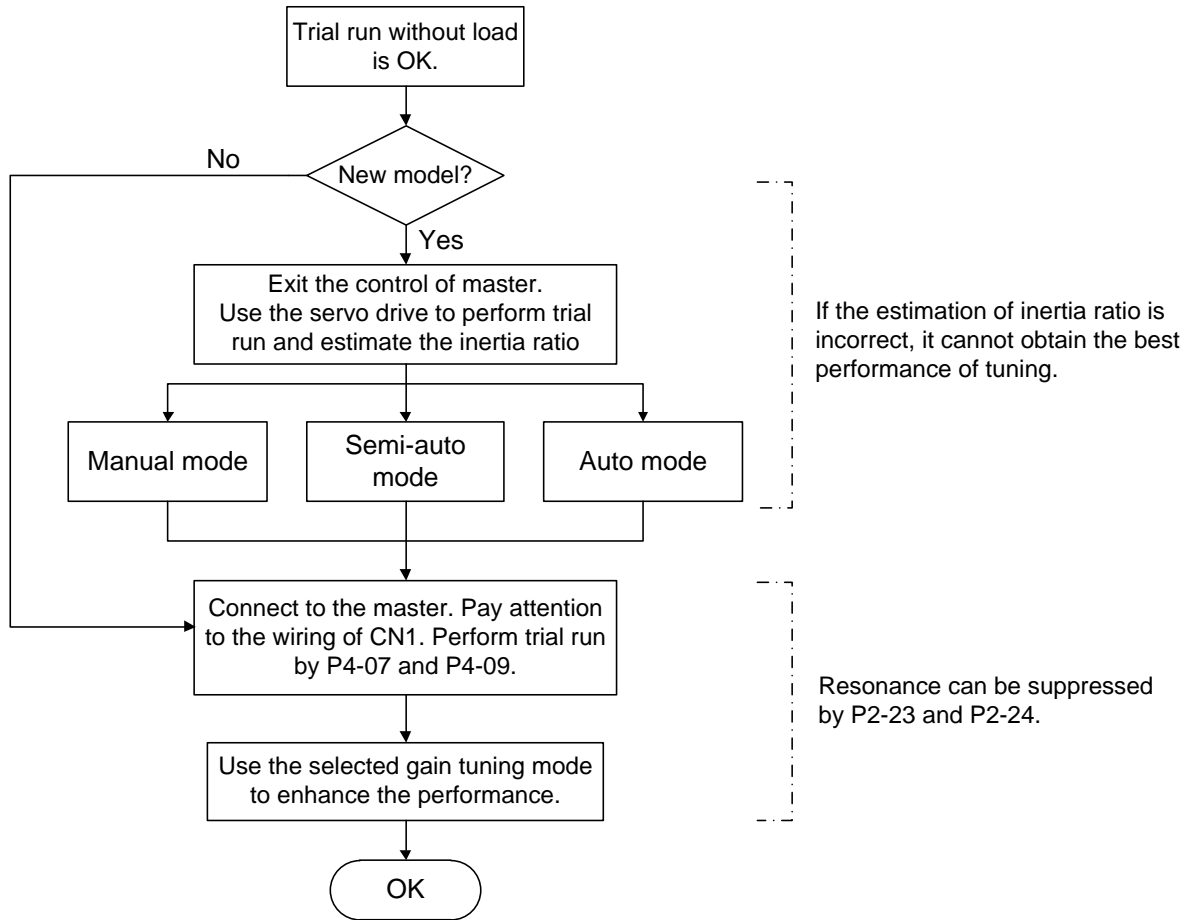

Note: Inertia ratio is for rotary motor; while total weight of movable section and load (kg) is for linear motor.

5.6.2 Inertia Estimation Flowchart (with Mechanism)

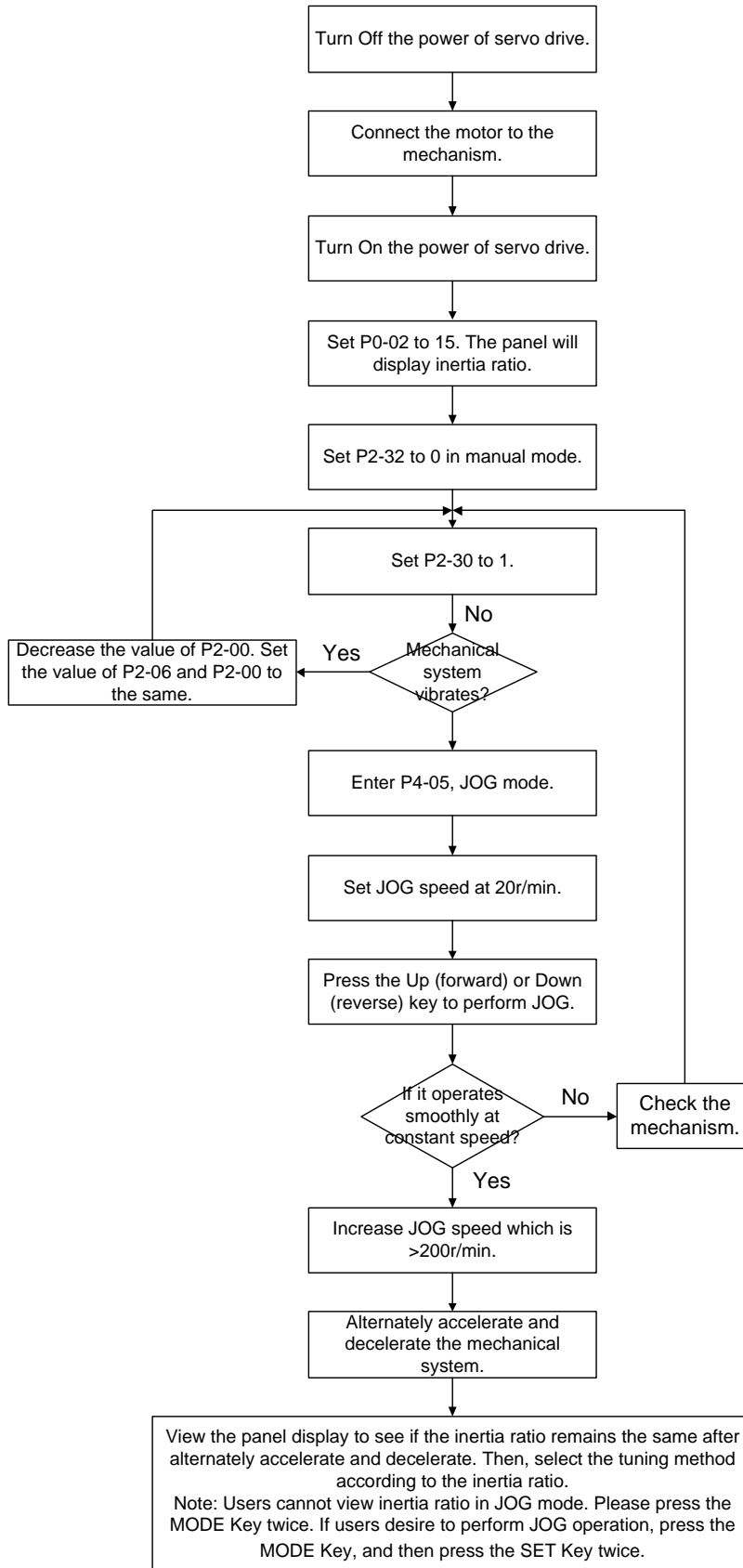

Note: Inertia ratio is for rotary motor; while total weight of movable section and load (kg) is for linear motor

5.6.3 Flowchart of Auto Tuning

Description of Auto Tuning:

Set P2-32 to 1. Continue to estimate the system inertia. Automatically save the value in P1-37 every 30 minutes and refer the stiffness and bandwidth setting of P2-31. Increase the value of P2-31 to increase stiffness or decrease to reduce the noise. Continue to tune until the performance is satisfied. Then, tuning is completed.

P2-31 Stiffness setting in auto tuning mode (The default value is 80), the bigger the value is, the stronger the stiffness will be.

In auto and semi-auto mode, the bandwidth setting of speed circuit is:

1~50Hz: low-stiffness, low-response

51~250Hz: medium-stiffness, medium-response

251~850Hz: high-stiffness, high-response

851~1000Hz: extremely high-stiffness, extremely high-response

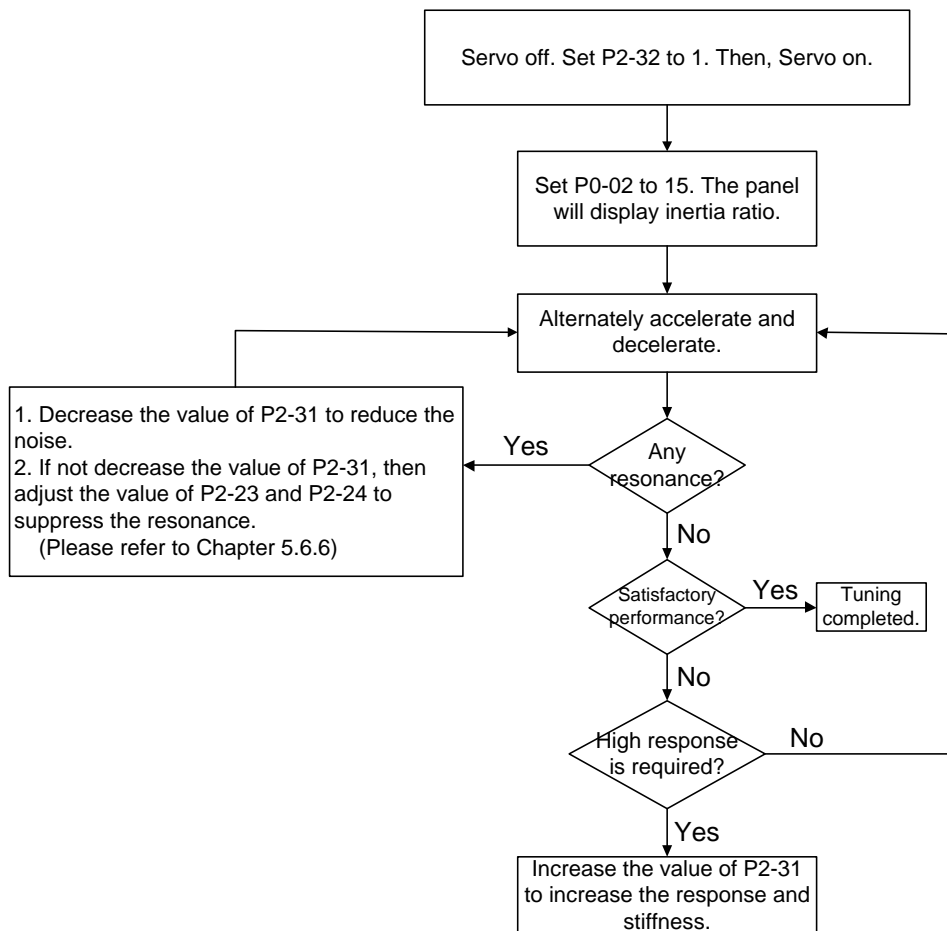

Note: Inertia ratio is for rotary motor; while total weight of movable section and load (kg) is for linear motor

5.6.4 Flowchart of Semi-auto Tuning

Description of Semi-auto Tuning:

Set P2-32 to 2. After tuning for a while and wait until the system inertia is stable, it stops estimating. The estimated inertia ratio will be saved to P1-37. When switching mode from manual or auto to semi auto, the system starts tuning again. During the process of estimation, the system will refer the stiffness and bandwidth setting of P2-31. Increase the value of P2-31 to increase the response or decrease to reduce the noise. Continue to tune until the performance is satisfied. Then, tuning is completed.

P2-31: Response setting in auto mode (The default value is 80). The bigger the value is, the better the response will be.

In auto and semi-auto mode, the bandwidth setting of speed circuit is:

1~50Hz: low-stiffness, low-response

51~250Hz: medium-stiffness, medium-response

251~850Hz: high-stiffness, high-response

851~1000Hz: extremely high-stiffness, extremely high-response

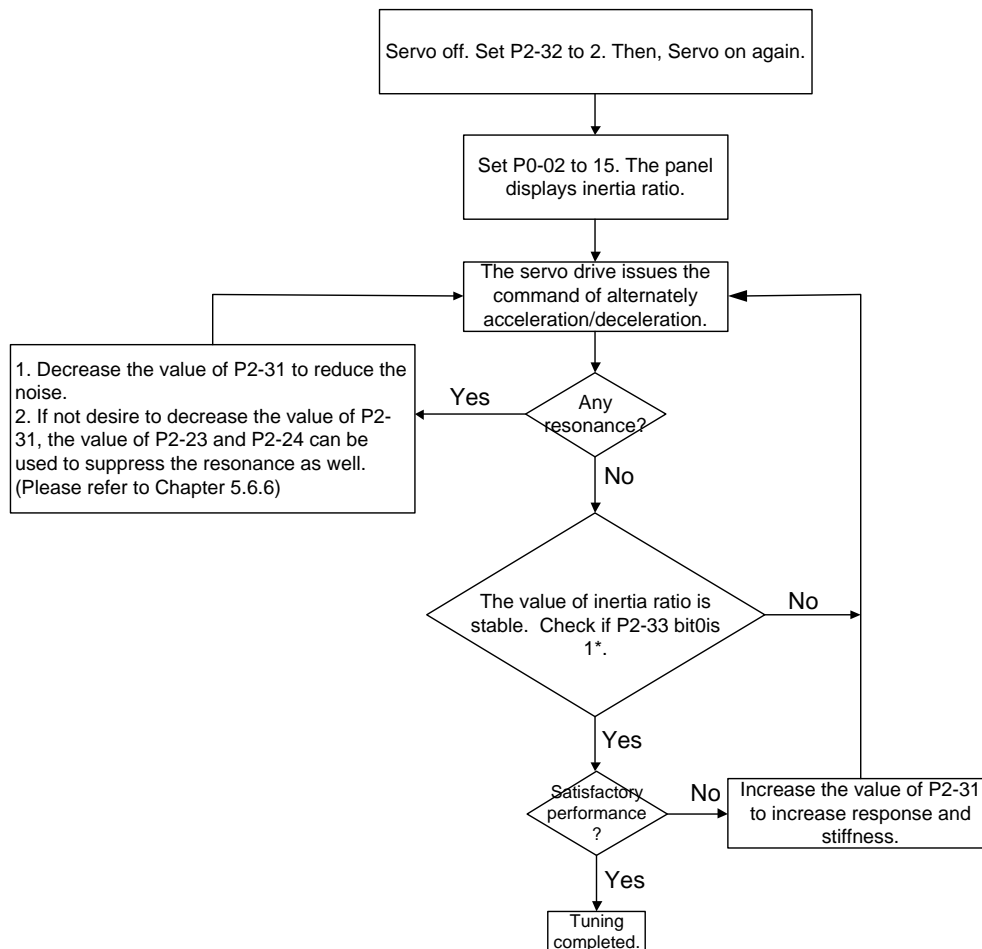

Note:

- Note: Inertia ratio is for rotary motor; while total weight of movable section and load (kg) is for linear motor
- If P2-33 bit 0 is set to 1, it means the inertia estimation in semi-auto mode is completed. The result can be accessed by P1-37. If the value of P2-33 bit 0 is cleared to 0, the system will start to estimate again.

5.6.5 Limit of Inertia Ratio for Rotary Motor / Total Weight of Linear Motor and Load (kg)

Limitation:

Rotary Motor	Linear Motor
1. Acceleration / Deceleration time of reaching 2000r/min should be less than 1 second.	1. Acceleration / Deceleration time of reaching 1m/s should be less than 0.24 second.
2. The speed in forward and reverse direction should be higher than 200r/min.	2. The moving speed should > 0.01m/s.
3. The load inertia should be under 100 times of motor inertia.	3. The load inertia should be under 100 times of motor inertia.
4. The change of external force of inertia ratio cannot be too severe.	4. The change of external force of inertia ratio cannot be too severe.

Estimation:

In auto mode, the inertia value will be saved to P1-37 every 30 minutes; while in semi-auto mode, the inertia value will be saved to P1-37 only until the system inertia is stable and stops the estimation of load inertia.

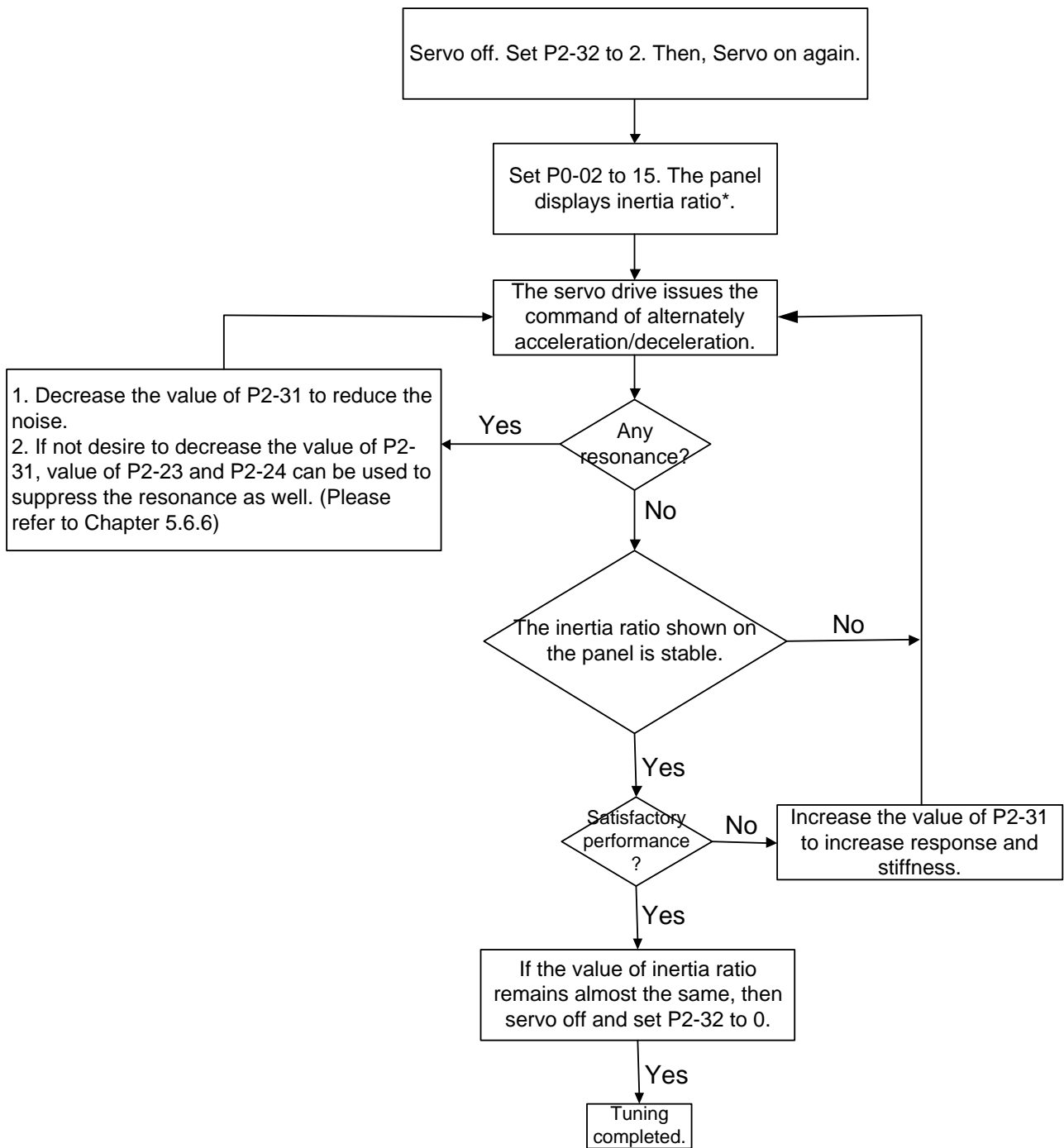

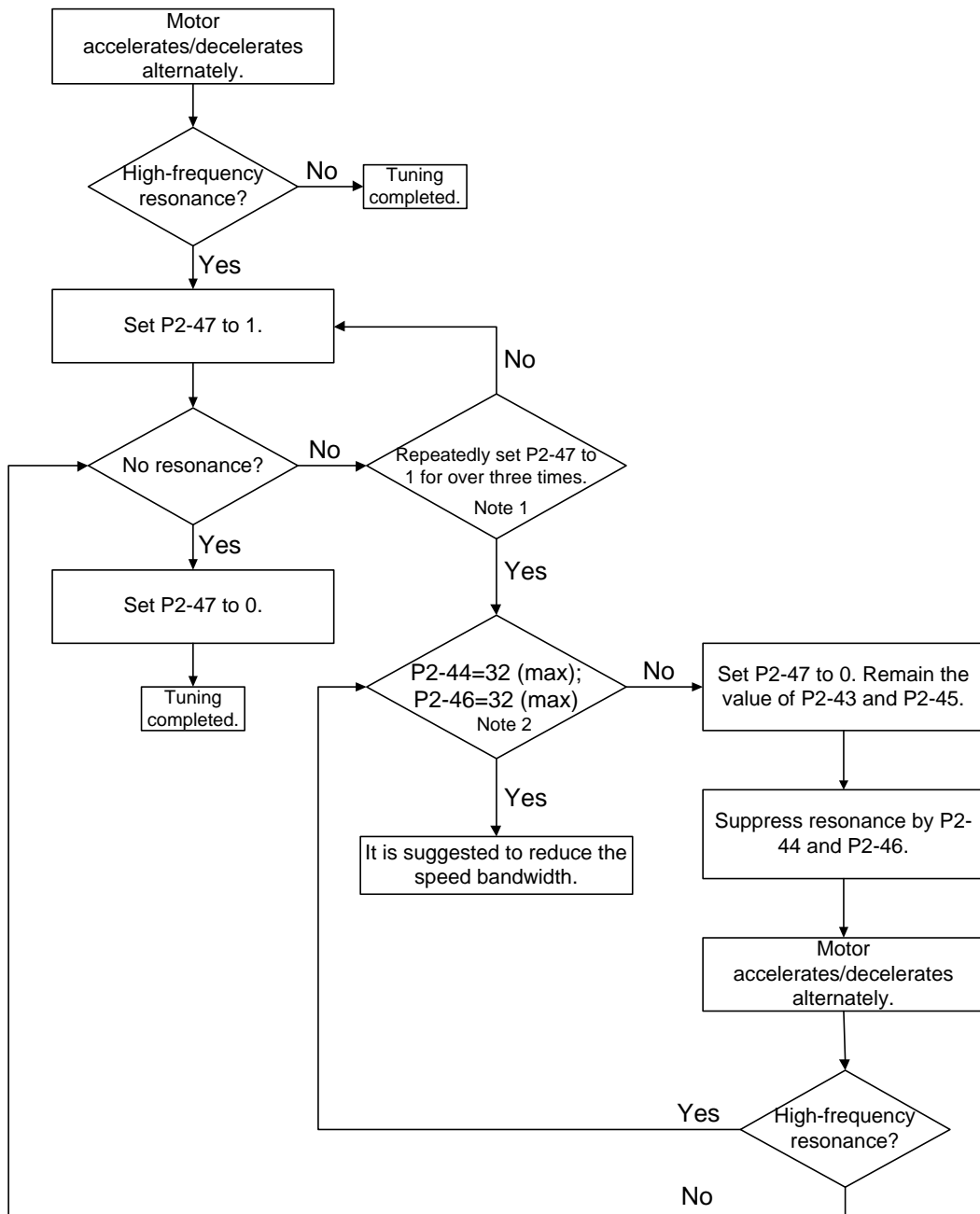

Note:

1. If resonance still exists, repeatedly set P2-47 to 1 for 3 times and manually adjust the setting of resonance.
2. Parameter P2-44 and P2-46 are the setting value of resonance suppression. If the value has been set to the maximum (32dB), and still cannot suppress the resonance, please reduce the speed bandwidth. After setting P2-47, users can check the value of P2-44 and P2-46. If the value of P2-44 is not 0, it means the resonance frequency exists in the system. Then, users can access P2-43 to see the resonance frequency (Hz). When there is another resonance frequency, the information will be shown in P2-45 and p2-46.
3. Inertia ratio is for rotary motor; while total weight of movable section and load (kg) is for linear motor

5.6.6 Mechanical Resonance Suppression Method

Three groups of Notch filter are provided to suppress mechanical resonance. Two of them can be set to the auto resonance suppression and manual adjustment.

The procedure of manually suppress the resonance is as the followings:

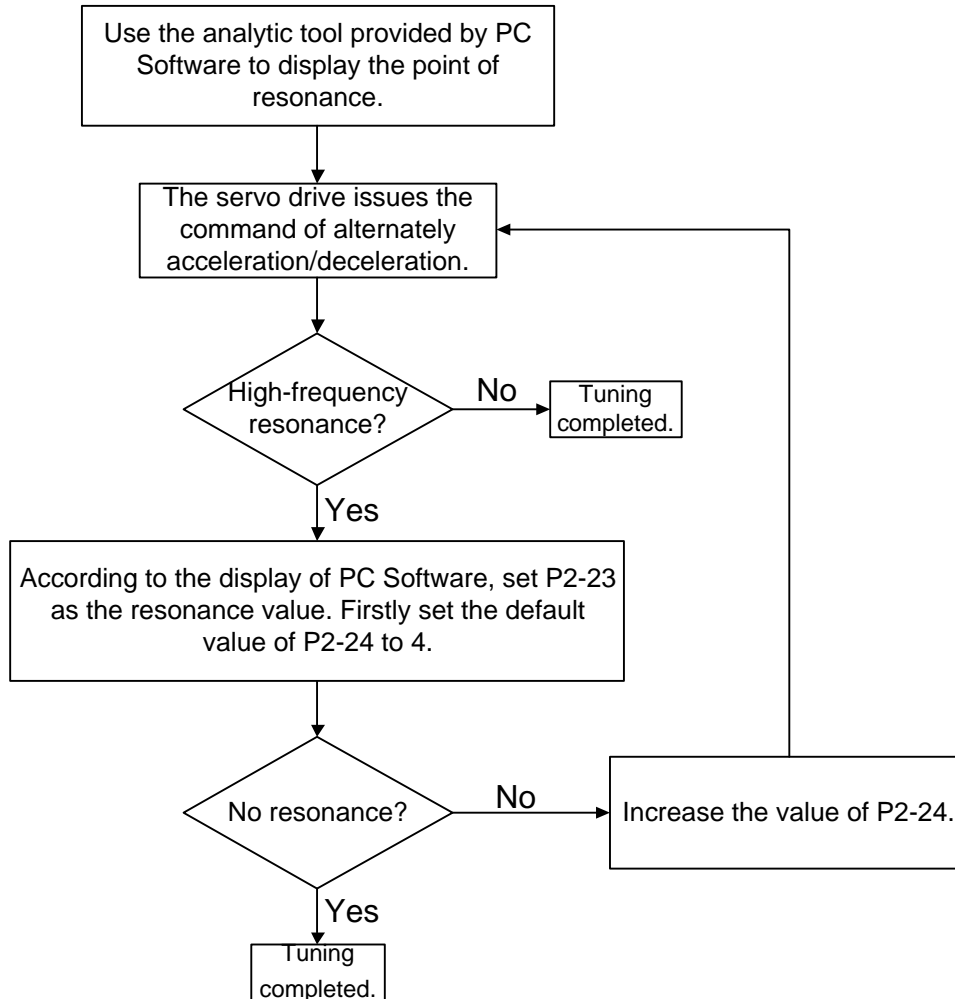

5.6.7 Tuning Mode and Parameters

Tuning mode	P2-32	Auto-set parameters	User-defined parameters	Inertia adjustment
Manual mode	0 (default setting)	N/A	P1-37 (Inertia ratio of the motor) P2-00 (Position control gain) P2-04 (Speed control gain) P2-06 (Speed integral compensation) P2-25 (Low-pass filter of resonance suppression) P2-26 (Anti-interference gain)	The value remains
Auto mode (continuous estimation)	1	P1-37 P2-00 P2-02 P2-04 P2-06 P2-25 P2-26 P2-49	P2-31 Frequency response of speed loop setting in auto mode (response level)	Continuous tuning (update the inertia every 30 minutes)
Semi-auto mode (non-continuous estimation)	2	P1-37 P2-00 P2-02 P2-04 P2-06 P2-25 P2-26 P2-49	P2-31 Frequency response of speed loop setting in semi-auto mode (response level)	Non-continuous tuning (stop updating the inertia after operating for a while)

When switching mode from auto mode 1 to manual mode 0, the value of P2-00, P2-02, P2-04, P2-06, P2-25, P2-26 and P2-49 will be modified to the one in auto mode.

When switching mode from semi-auto mode 2 to manual mode 0, the value of P2-00, P2-02, P2-04, P2-06, P2-25, P2-26 and P2-49 will be modified to the one in semi-auto mode.

5.6.8 Tuning in Manual Mode

The selection of position / speed response frequency should be determined by the machinery stiffness and application. General speaking, the high-frequency machinery or the one requires precise processing needs the higher response frequency. However, it might easily cause the resonance. And the stronger stiffness machinery is needed to avoid the resonance. When using the unknown resonance frequency machinery, users could gradually increase the gain setting value to increase the resonance frequency. Then, decrease the gain setting value until the resonance exists. The followings are the related descriptions of gain adjustment.

Position control gain (KPP, parameter P2-00)	
Description	This parameter determines the response of position loop. The bigger KPP value will cause the higher response frequency of position loop. And it will cause better following error, smaller position error, and shorter settling time.
Note	If the value is set too big, the machinery will vibrate or overshoot when positioning.
Calculation	Position Loop Frequency Response (Hz) = $\frac{KPP}{2\pi}$

Speed control gain (KVP, parameter P2-04)	
Description	This parameter determines the response of speed loop. The bigger KVP value will cause the higher response frequency of speed loop and better following error.
Note	If the value is set too big, it would easily cause machinery resonance. The response frequency of speed loop must be 4~6 times higher than the response frequency of position loop. Otherwise, the machinery might vibrate or overshoot when positioning.
Calculation	<p>Speed Loop Frequency Response $f_v = \left(\frac{KVP}{2\pi}\right) \times \left[\frac{(1+P1-37/10)}{(1+JL/JM)}\right]$ Hz</p> <p>JM: motor inertia JL: load inertia P1-37: 0.1 times</p> <p>When P1-37 (estimation or setting) equals the real inertia ratio (JL/JM), the real speed loop frequency response will be: $f_v = \frac{KVP}{2\pi}$ Hz</p>

Speed integral compensation (KVI, parameter P2-06)	
Description	The higher the KVI value is, the better capability of eliminating the deviation will be.
Note	If the value is set too big, it might easily cause the vibration of machinery.
Calculation	KVI (Parameter P2-06) $\leq 1.5 \times$ Speed Loop Frequency Response

Low-pass filter of resonance suppression (NLP, parameter P2-25)	
Description	The high value of inertia ratio will reduce the frequency response of speed loop. Therefore, the KVP value must be increased to maintain the response frequency.
Note	During the process of increasing KVP value, it might cause machinery resonance. Please use this parameter to eliminate the noise of resonance. The bigger the value is, the better the capability of improving high-frequency noise will be. However, if the value is set too big, it would cause the instability of speed loop and overshoot.
Calculation	It is suggested to set the value as the following: $\text{NLP (Parameter P2-25)} \leq \frac{1000}{6 \times \text{Speed Loop Frequency Response (Hz)}}$

Anti-interference gain (DST, parameter P2-26)	
Description	This parameter is used to strengthen the ability of resisting external force and gradually eliminate overshoot during acceleration / deceleration. Its default value is 0. It is suggested not to adjust the value in manual mode, unless it is for fine-tuning.

Position feed forward gain (PFG, parameter P2-02)	
Description	It can reduce the position error and shorten the settling time.
Note	If the value is set too big, it might cause overshoot. If the setting of e-gear ratio is bigger than 10, it might cause the noise as well.

Chapter 6 Control Mode of Operation

6.1 Selection of Operation Mode

Three basic operation modes are provided in this servo drive, position, speed and torque (force). Users can use single mode (only in one-mode control) and dual mode to control. The following table lists all operation mode and description.

Mode Name	Short Name	Setting Code	Description	
Single Mode	Position mode (Terminal input)	PT	00	The servo drive receives position command and commands the motor to the target position. The position command is input via terminal block and receives pulse signal.
	Position mode (Register input)	PR	01	The servo drive receives position command and commands the motor to the target position. The position command is issued by register (64 sets of register in total) and uses DI signal to select the register.
	Speed Mode	S	02	The servo drive receives speed command and commands the motor to the target speed. The speed command can be issued by register (3 sets of registers in total) or the external analog voltage (-10V ~ +10V). DI signal is used to select the command source.
	Speed mode (No analog input)	Sz	04	The servo drive receives speed command and commands the motor to the target speed. The speed command is issued by register (3 sets of registers in total) and cannot be issued by the external terminal block. DI signal is used to select the command source.
	Torque (force) mode	T	03	The servo drive receives torque (force) command and commands the motor to the target torque. The torque (force) command can be issued by register (3 sets of registers in total) or the external analog voltage (-10V ~ +10V). DI signal is used to select the command source.
	Torque (force) mode (No analog input)	Tz	05	The servo drive receives torque (force) command and commands the motor to the target torque (force). The torque (force) command can be issued by register (3 sets of registers in total) and cannot be issued by the external terminal block. DI signal is used to select the command source.

Mode Name	Short Name	Setting Code	Description
Dual Mode	PT-S	06	Switch the mode of PT and S via DI signal.
	PT-T	07	Switch the mode of PT and T via DI signal.
	PR-S	08	Switch the mode of PR and S via DI signal.
	PR-T	09	Switch the mode of PR and T via DI signal.
	S-T	0A	Switch the mode of S and T via DI signal.
	CANopen	0B	Control by the master
	Reserved	0C	Reserved
	PT-PR	0D	Switch the mode of PT and PR via DI signal.
Multi Mode	PT-PR-S	0E	Switch the mode of PT, PR and S via DI signal.
	PT-PR-T	0F	Switch the mode of PT, PR and T via DI signal.

Steps of switching mode:

1. Servo Off the servo drive first. It can be done by switching OFF SON signal.
2. Select the axis of desired changing mode first. Then, fill in the setting code in control mode setting of parameter P1-01. Please refer to the description of Chapter 8.
3. After the setting is completed, turn off the servo drive and then re-power on will do.

The followings will introduce the operation of each mode, including the mode structure, command source and selection, command processing and gain adjustment.

6.2 Position Mode

The followings describe the related information and settings of position mode.

6.2.1 Position Command in PT Mode

PT, position command is the pulse input from terminal block. There are three types of pulse and each type has positive/negative logic which can be set in parameter P1-00. Related parameter: Please refer to Chapter 8 for further information.

Parameter	Abbr.	Function
P1-00	PTT	External Pulse Input Type

Position pulse can be input from CN1 terminal, PULSE (43), /PULSE (41), HPULSE (38), /HPULSE (29) and SIGN (36), /SIGN (37), HSIGN (46), /HSIGN (40). It could be open-collector or Line Driver. Please refer to Chapter 3.10.1 for wiring method.

6.2.2 Position Command in PR Mode

PR position command source of each axis is from the 64-set of register which constituted by parameters (P6-00, P6-01) ~ (P7-26, P7-27). When going with the external DI/DO (CN1, POS0 ~POS5 and CTRG), one of the previous 64 sets of register can be selected as the position command. See as the following table:

Position Command	POS5	POS4	POS3	POS2	POS1	POS0	CTRG	Corresponding Parameter
P0	0	0	0	0	0	0	↑	P6-00 P6-01
P1	0	0	0	0	0	1	↑	P6-02 P6-03
~								~
P50	1	1	0	0	1	0	↑	P6-98 P6-99
P51	1	1	0	0	1	1	↑	P7-00 P7-01
~								~
P63	1	1	1	1	1	1	↑	P7-26 P7-27

Status of POS0 ~ POS5: 0 means the DI is OFF; 1 means the DI is ON.

CTRG↑: the moment DI is OFF to ON.

The application of absolute type and incremental type register is rather extensive. It is more like a simple procedure control. Users can complete the cyclic operation by referring to the above table. For example, position command P1 is 10 turns and P2 is 20 turns. P1 is issued first and P2 comes after. The following diagram shows the difference of both.

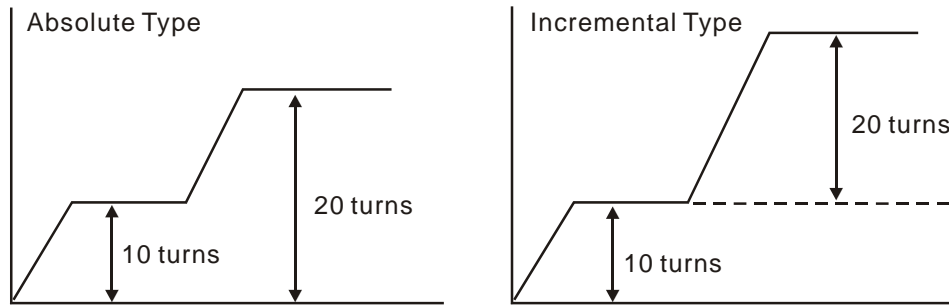

6.2.3 Control Structure of Position Mode

The basic control structure is as the following diagram:

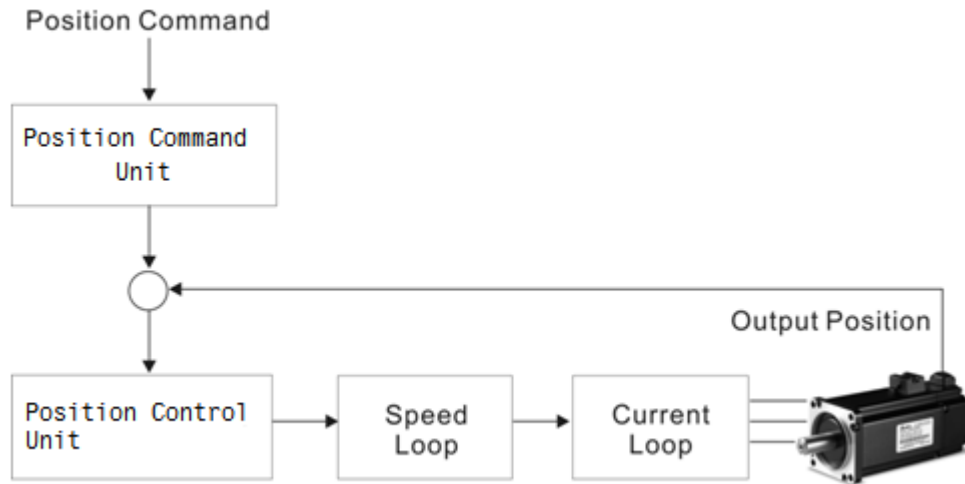

For a better control, the pulse signal should be processed and modified through position command unit. Structure is shown as the diagram below.

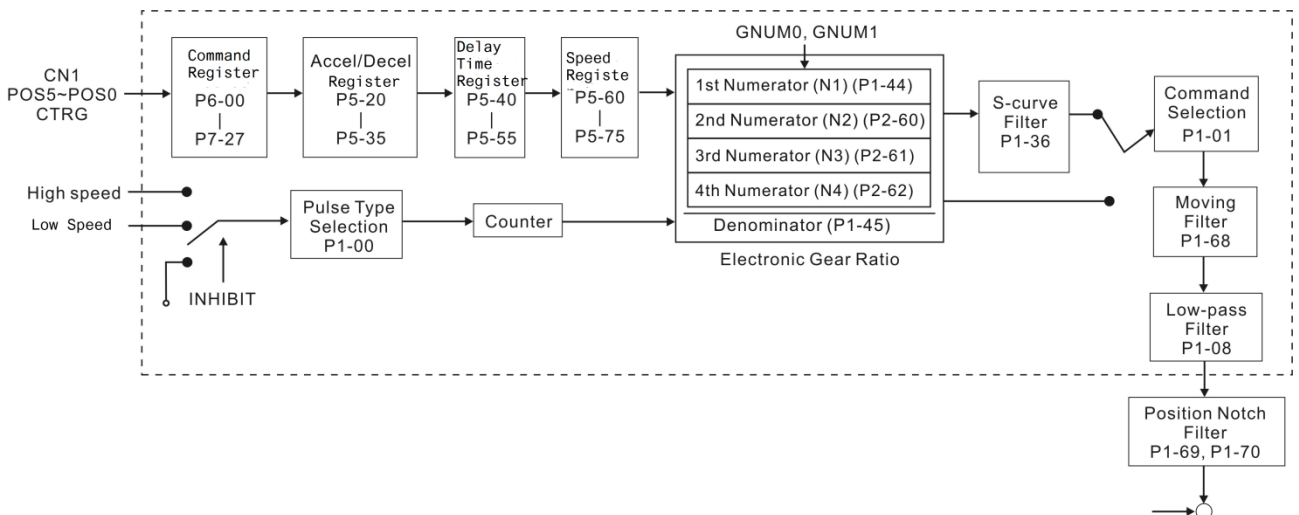

The upper path of the above diagram is PR mode and the lower one is PT mode which could be selected via P1-01. Both modes can set E-gear ratio for the proper position resolution. Moreover, either S-curve filter or low-pass filter can be used to smooth the command. See the description in later parts.

Pulse Command Inhibit Function (INHP)

Use DI to select INHP (Refer to P2-10~17 and table 8.1 INHP (45)) before using this function. If not, this function will be unable to use. When DI (INHP) is ON, the pulse command will be cleared in position control mode and the motor will stop running. (Only DI 8 supports this function.)

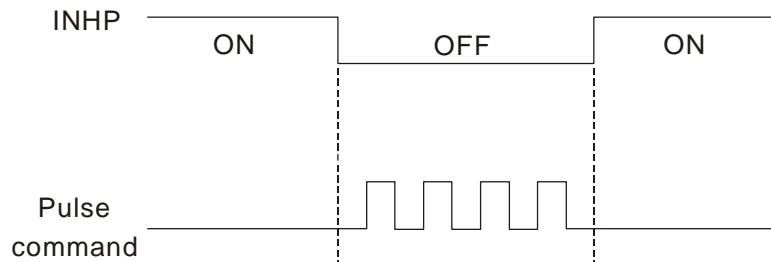

6.2.4 S-curve Filter (Position)

S-curve filter smoothes the motion command. With S-curve filter, the process of acceleration becomes more continuous and the jerk will be smaller. It not only improves the performance when motor accelerates / decelerates, but also smoothes the operation of mechanical structure. When the load inertia increases, the operation of the motor will be influenced by friction and inertia during the time of activation and stop. However, the situation can be improved by increasing the value of Acceleration / Deceleration Constant of S-Curve (TSL), Acceleration Constant of S-Curve (TACC) and Deceleration Constant of S-Curve (TDEC). When the position command source is pulse, its speed and angular acceleration is continuous, thus, S-curve filter is not a must.

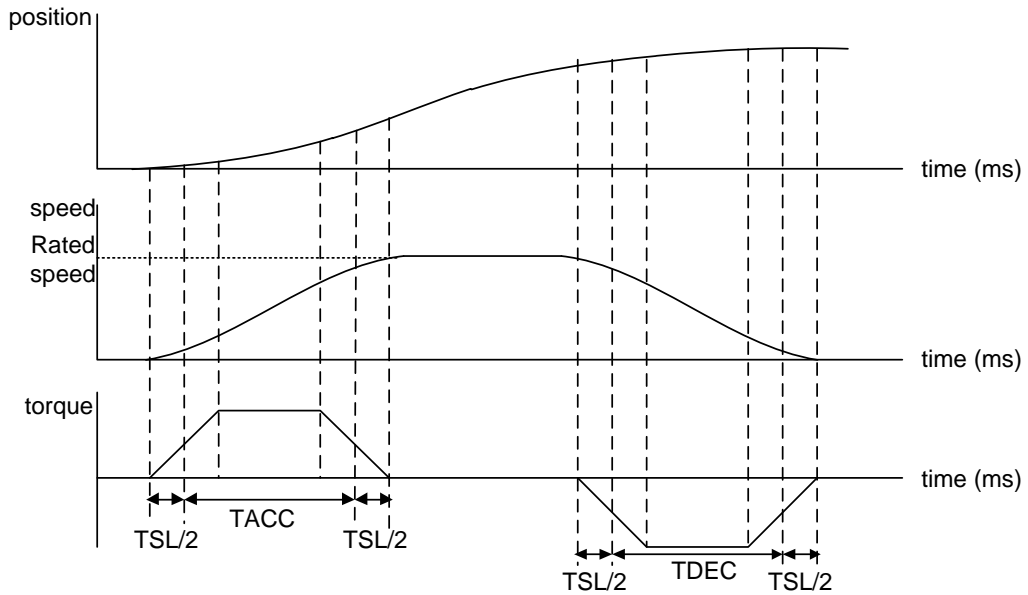

Position and speed S-curve and time setting (acceleration for position command)

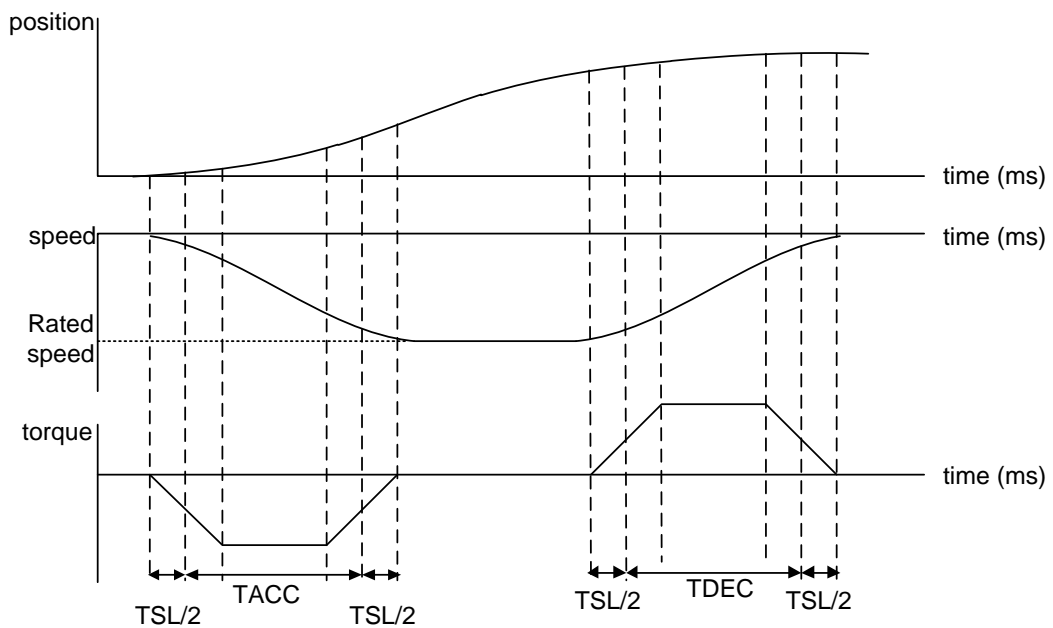

Position and speed S-curve and time setting (deceleration for position command)

Related parameters: Please refer to Chapter 8 for further information

Parameter	Abbr.	Function
P1-34	TACC	Acceleration Constant of S-Curve
P1-35	TDEC	Deceleration Constant of S-Curve
P1-36	TSL	Acceleration / Deceleration Constant of S-Curve

6.2.5 Electronic Gear Ratio

Related parameters: Please refer to Chapter 8 for further information

Parameter	Abbr.	Function
P1-44	GR1	Gear Ratio (Numberator) (N1)
P1-45	GR2	Gear Ratio (Denominator) (M)

$$\text{E-Gear ratio} = \left(\frac{N}{M}\right) = \frac{P1-44}{P1-45}, \text{ has to match } \frac{1}{50} \leq \left(\frac{N}{M}\right) \leq 5000$$

Electronic gear provides simple ratio change of travel distance. The high electronic gear ratio would cause the position command to be the stepped command. S-curve or low-pass filter can be used to improve the situation. When electronic gear ratio is set to 1, the motor will turn one cycle for every 1280000PUU. When electronic gear ratio is changed to 0.5, then every two pulses from the command will refer to one PUU of motor encoder.

For example (rotary motor): after setting the electronic gear ratio properly, the moving distance of the object is 1µm/pulse, which is easier to use.

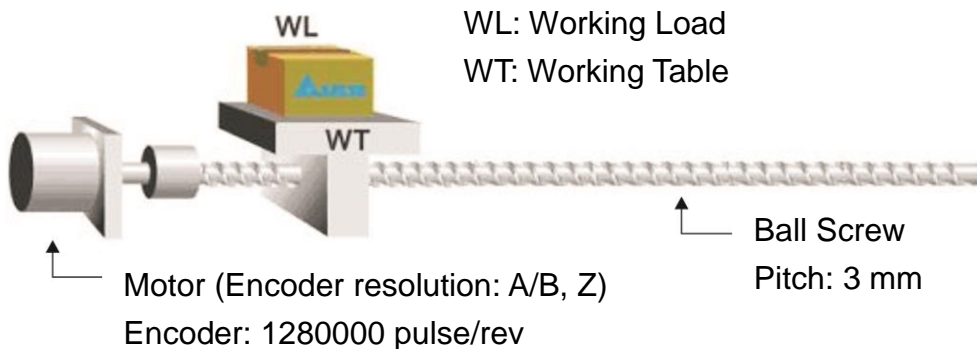

	Gear Ratio	Moving distance of each pulse command
Electronic gear is unapplied.	$\frac{1}{1}$	$= \frac{3 \times 1000}{4 \times 2500} = \frac{3000}{10000} = \mu\text{m}$
Electronic gear is applied.	$= \frac{10000}{3000}$	$= 1\mu\text{m}$

6.2.6 Low-pass Filter

Related parameters: Please refer to Chapter 8 for further information

Parameter	Abbr.	Function
P1-08	PFLT	Smooth Constant of Position Command (Low-pass filter)

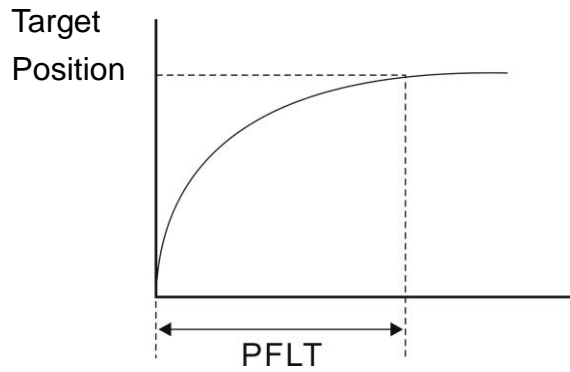

6.2.7 Timing Diagram in Position Mode (PR)

In PR mode, the position command is selected by either DI signal (POS0~POS5 and CTRG) of CN1 or communication. Please refer to Section 6.2.2 for the information about DI signal and its selected register. Followings are the timing diagrams.

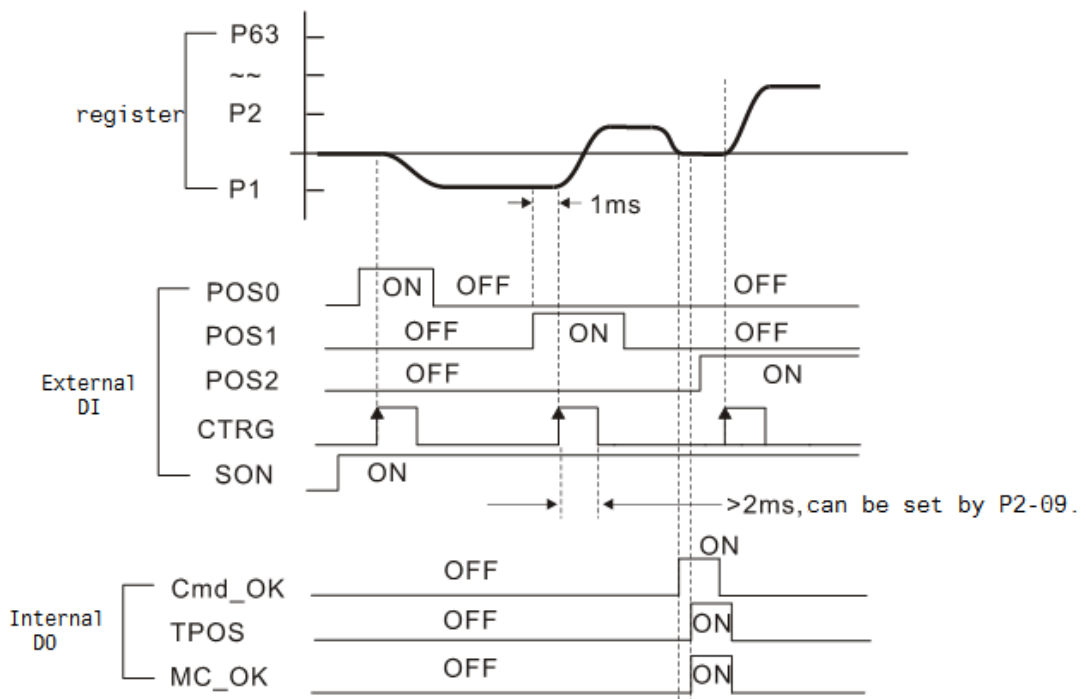

Cmd_OK: will be output after PR command is completed.
 TPOS: will be output when the motor speed is slower than P1-38 setting value.
 MC_OK: will be output when Cmd_OK and TPOS are output.

6.2.8 Gain Adjustment of Position Loop

Before setting the position control unit, users have to manually (P2-32) complete the setting of speed control unit since the speed loop is included in position loop. Then, set the proportional gain (parameter P2-00) and feed forward gain (parameter P2-02) of position loop. Users also can use the auto mode to set the gain of speed and position control unit automatically.

- 1) Proportional gain: Increase the gain so as to enhance the response bandwidth of position loop.
- 2) Feed forward gain: Minimize the deviation of phase delay

The position loop bandwidth cannot exceed the speed loop bandwidth. It is suggested that $f_p \leq \frac{f_v}{4}$.

f_v : response bandwidth of speed loop (Hz).

$$KPP = 2 \times \pi \times f_p$$

f_p : response bandwidth of position loop (Hz).

For example, the desired position bandwidth is 20 Hz $\rightarrow KPP = 2 \times \pi \times 20 = 125$.

Related parameters: Please refer to Chapter 8 for further information.

Parameter	Abbr.	Function
P2-00	KPP	Position Loop Gain
P2-02	PFG	Position Feed Forward Gain

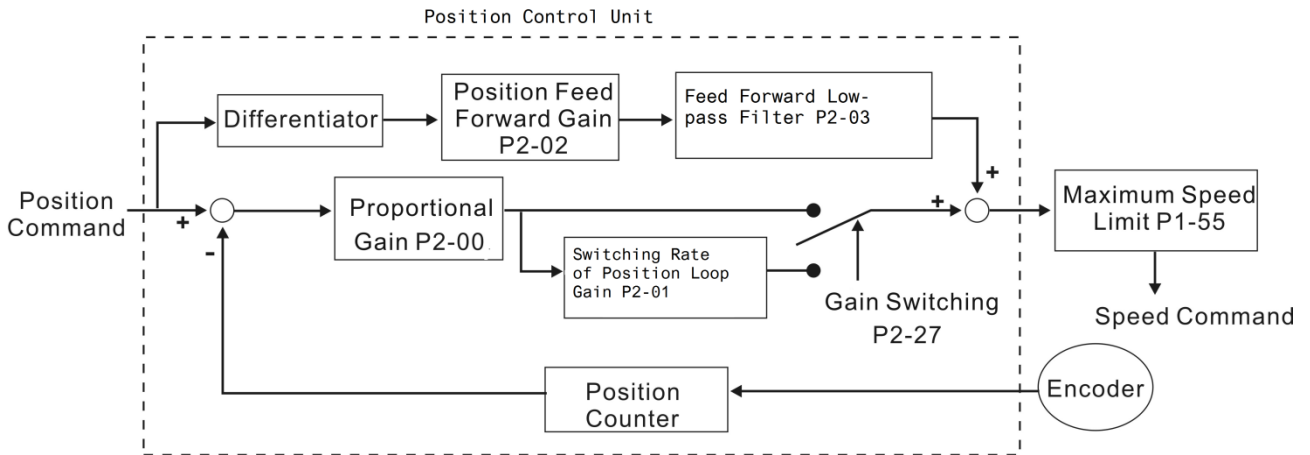

When the value of proportional gain, KPP is set too big, the response bandwidth of position loop will be increased and diminish the phase margin. And the motor rotor rotates vibrantly in forward and reverse direction at the moment. Thus, KPP has to be decreased until the rotor stops vibrating. When the external torque interrupts, the over-low KPP cannot meet the demand of position deviation. In this situation, parameter P2-02 can effectively reduce the position error.

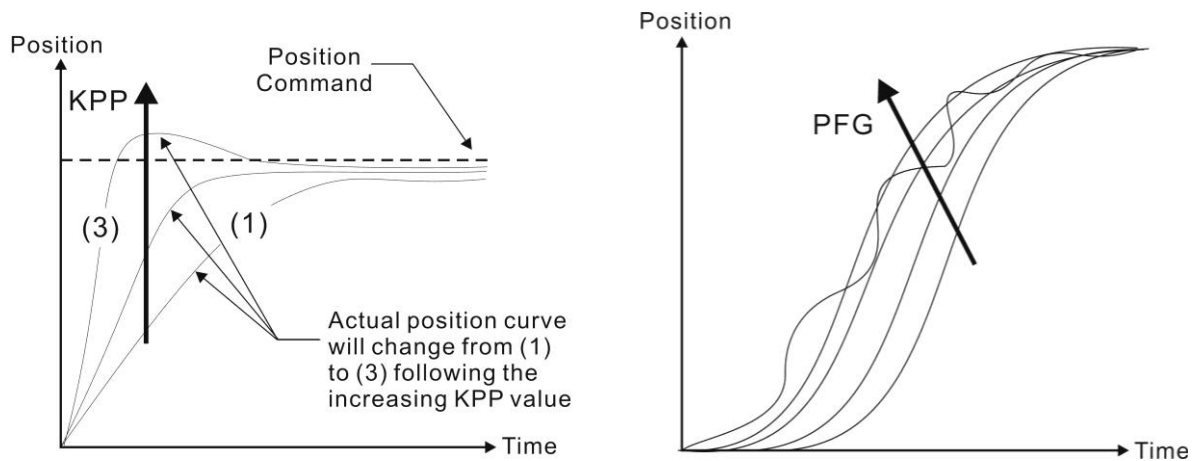

6.2.9 Low-frequency Vibration Suppression in Position Mode

If the stiffness is not enough, the mechanical transmission will continue to vibrate even when the motor stops after completing the positioning command. The function of low-frequency vibration suppression can eliminate the vibration of mechanical transmission. The range is between 1.0Hz and 100.0HZ. Both manual setting and auto setting are provided.

Auto setting:

If the frequency is hard to find, it can enable the function of auto low-frequency vibration suppression. This function automatically searches the frequency of low-frequency vibration. If P1-29 is set to 1, the system will disable the function of low-frequency vibration suppression automatically and starts to search the vibration frequency. When the detected frequency remains at the same level, P1-29 will be set to 0 automatically and set the first frequency in P1-25 and set P1-26 to 1. The second frequency will be set in P1-27 and then set P1-28 to 1. If P1-29 is automatically set back to 0 and still has low-frequency vibration, please check if the function of P1-26 or P1-28 is enabled. If the value of P1-26 and P1-28 is 0, it means no frequency has been detected. Please decrease the value of P1-30 and set P1-29 to 1 so as to search the vibration frequency again. Please note that when the detection level is set too small, the noise will be regarded as the low-frequency.

Flowchart of auto low-frequency vibration suppression:

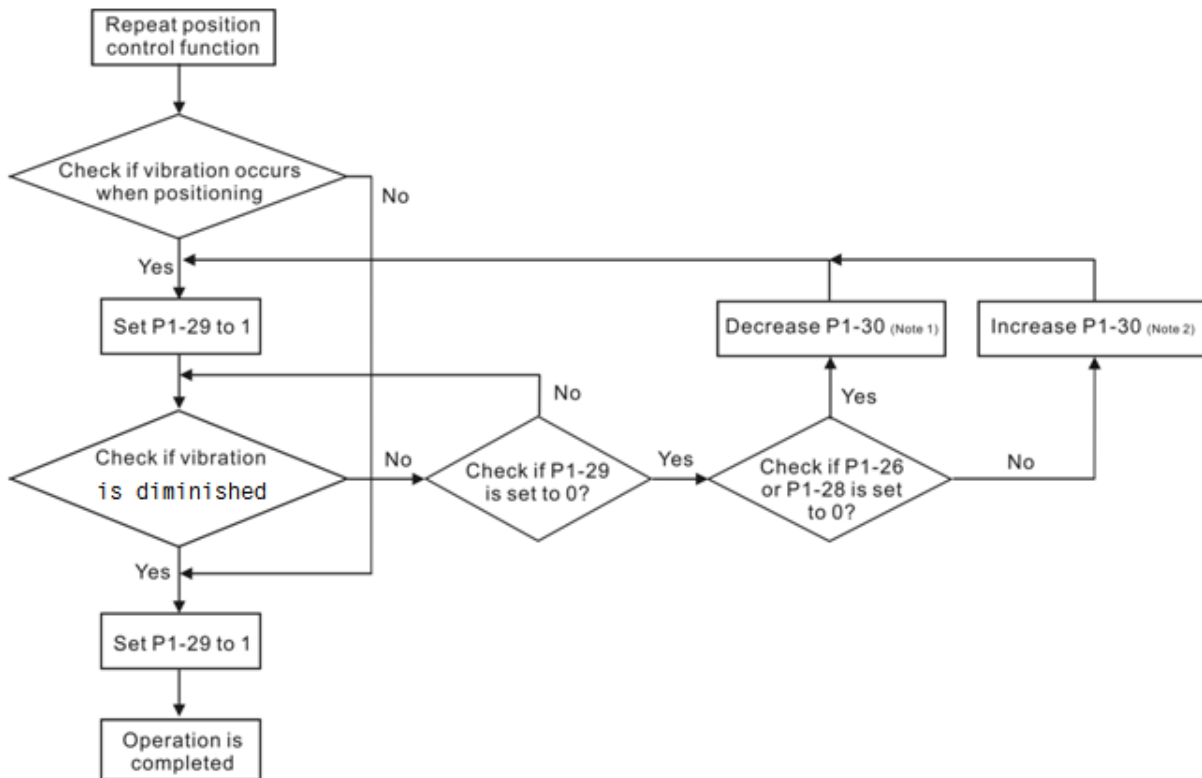

Note 1: When the value of P1-26 and P1-28 is 0, it means it is unable to search the frequency. It is probably because the detection level is set too high and is unable to detect the low-frequency vibration.

Note 2: When the value of P1-26 or P1-28 is not set to 0 and still cannot eliminate the vibration, it is probably because the detection level is set too low, the system regards the noise or other non-primary frequency as the low-frequency vibration.

Note 3: When the process of auto vibration suppression is completed and the vibration still cannot be diminished, P1-25 or P1-27 can be manually set to suppress the vibration if the frequency (Hz) of the low-frequency is identified.

Related parameters: Please refer to Chapter 8 for further information.

Parameter	Abbr.	Function
P1-29	AVSM	Auto Low-frequency Vibration Suppression Setting
P1-30	VCL	Low-frequency Vibration Detection

P1-30 is to set the range to detect the magnitude of low-frequency vibration. When the frequency is not being detected, it is probably because the value of P1-30 is set too big which exceeds the range of vibration. It is suggested to decrease the value of P1-30. Please note that if the value is too small, the system might regard the noise as the vibration frequency. If the SCOPE is available, it can be used to observe the range of position error (pulse) between upper and lower magnitude of the curve and set up the appropriate value of P1-30.

Manual Setting:

There are two sets of low-frequency vibration suppression. One is parameter P1-25~P1-26 and another one is parameter P1-27~P1-28. These two sets of low-frequency vibration suppression can be used to eliminate two different frequency vibration. Parameter P1-25 and P1-27 are used to suppress the low-frequency vibration. The function is working only when the parameter setting value of low-frequency vibration close to the real vibration frequency. Parameter P1-26 and P1-28 are used to set the response after filter. The bigger the setting value of P1-26 and P1-28 is, the better response will be. However, if the value is set too big, the motor might not operate smoothly. The default value of parameter P1-26 and P1-28 is 0, which means the function is disabled.

Related parameters: Please refer to Chapter 8 for further information.

Parameter	Abbr.	Function
P1-25	VSF1	Low-frequency Vibration Suppression (1)
P1-26	VSG1	Low-frequency Vibration Suppression Gain (1)
P1-27	VSF2	Low-frequency Vibration Suppression (2)
P1-28	VSG2	Low-frequency Vibration Suppression Gain (2)

6.3 Speed Mode

Speed control mode (S or Sz) is applicable in precision speed control, such as CNC machine tools. This servo drive includes two types of command input, analog and register. Analog command input can use external voltage to control the motor speed. There are two methods in register input. One is used before operation. Users set different value of speed command in three registers, and then use SPD0, SPD1 of CN1 DI signal for switching. Another method is to change the value of register by communication. In order to deal with the problem of non-continuous speed command when switching register, a complete S-curve program is provided. In close-loop system, this servo drive adopts gain adjustment and integrated PI controller and two modes (manual and auto) for selection.

Users can set all parameters and all auto or auxiliary function will be disabled in manual mode. While in auto mode, it provides the function of load inertia estimation and parameter adjustment. In auto mode, parameters which set by users will be regarded as the default value.

6.3.1 Selection of Speed Command

There are two types of speed command source, analog voltage and internal parameters. The selection is determined by CN1 DI signal. See as the followings.

Rotary Motor

Speed Command No.	CN1 DI Signal		Command Source			Content	Range
	SPD1	SPD0					
S1	0	0	Mode	S	External analog command	Voltage deviation between V-REF and GND	-10 V ~ +10V
				Sz	N/A	Speed command is 0	0
S2	0	1	Register parameters			P1-09	-60000 ~ 60000
S3	1	0				P1-10	-60000 ~ 60000
S4	1	1				P1-11	-60000 ~ 60000

Linear Motor

Speed Command No.	CN1 DI Signal		Command Source			Content	Range
	SPD1	SPD0					
S1	0	0	Mode	S	External analog command	Voltage deviation between V-REF and GND	-10 V ~ +10V
				Sz	N/A	Speed command is 0	0
S2	0	1	Register parameters			P1-09	-15999999 ~ 15999999
S3	1	0				P1-10	-15999999 ~ 15999999
S4	1	1				P1-11	-15999999 ~ 15999999

- Status of SPD0 ~ SPD1: 0 means DI OFF, 1 means DI ON.
- When both SPD0 and SPD1 are 0, if it is in Sz mode, the command will be 0. Thus, if there is no need to use analog voltage as the speed command, Sz mode can be applied to tackle the problem of zero-drift. If it is in S mode, the command will be the voltage deviation between V-REF and GND. The range of input voltage is between -10V and +10V and its corresponding speed is adjustable (P1-40).
- When one of SPD0 and SPD1 is not 0, the speed command is from the internal parameter. The command is activated after changing the status of SPD0~SPD1. There is no need to use CTRG for triggering.
- The setting range of internal parameters for rotary motor is between -60000 and 60000. Setting value = setting range x unit (0.1r/min).

For example: P1-09 = +30000, setting value = +30000 x 0.1r/min = +3000r/min

The setting range of internal parameters for linear motor is between -15999999 and 15999999. Setting value = setting range x unit (10^{-6} m/s).

For example: P1-09 = +30000, setting value = +30000 x 10^{-6} m/s = +0.03m/s

The speed command not only can be issued in speed mode (S or Sz), but also in torque mode (T or Tz) as the speed limit.

6.3.2 Control Structure of Speed Mode

The basic control structure is shown as the following diagram:

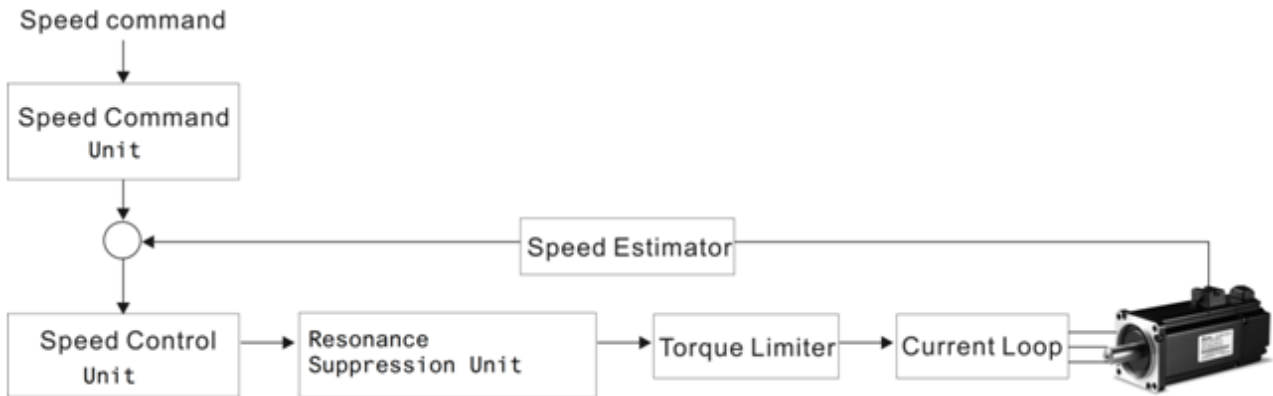

The speed command unit is to select speed command source according to Section 6.3.1, including the scaling (P1-40) setting and S-curve setting. The speed control unit manages the gain parameters of the servo drive and calculates the current command for servo motor in time. The resonance suppression unit is to suppress the resonance of mechanism. Detailed descriptions are shown as the following:
 Here firstly introduces the function of speed command unit. Its structure is as the following diagram.

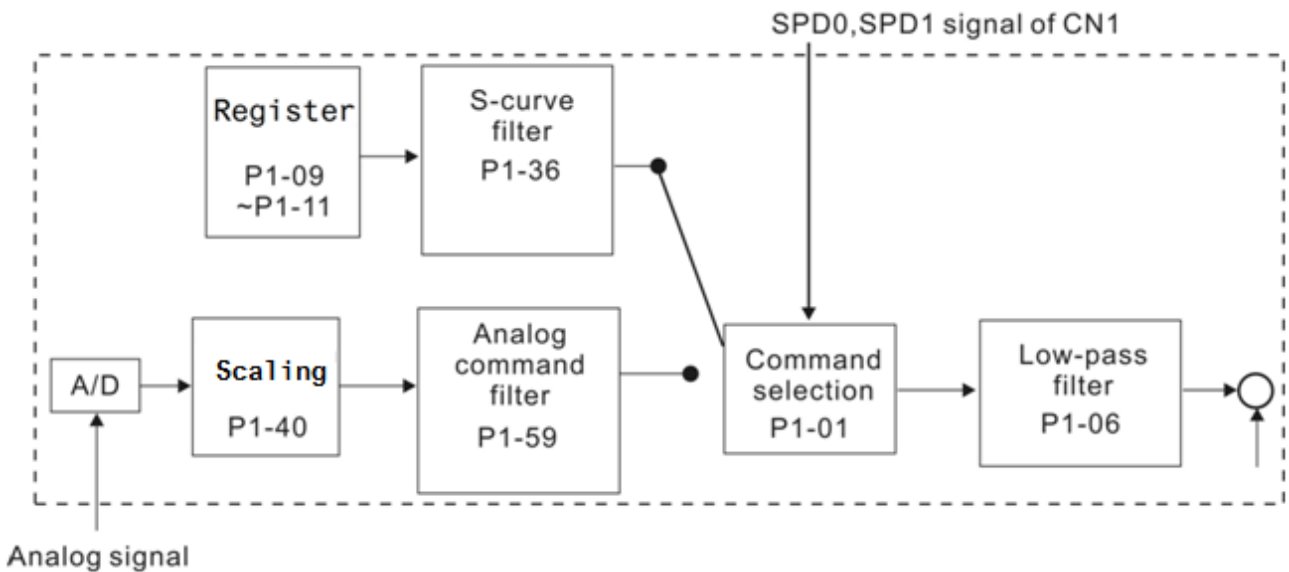

The upper path is the command from register while the lower one is external analog command. The command is selected according to the status of SPD0, SPD1 and P1-01(S or Sz). Usually, S-curve and low-pass filter are applied for having a smooth resonance of command.

6.3.3 Smooth Speed Command

S-curve Filter

During the process of acceleration or deceleration, S-curve filter applies the program of three-stage acceleration curve for smoothing the motion command, which generates the continuous acceleration. It is for avoiding the jerk (the differentiation of acceleration) came from the sudden command change and indirectly causes the resonance and noise. Users can use acceleration constant of S-curve (TACC) to adjust the slope changed by acceleration, deceleration constant of S-curve (TDEC) to adjust the slope changed by deceleration and acceleration / deceleration constant of S-curve (TSL) to improve the status of motor activation and stop. The calculation of the time to complete the command is provided.

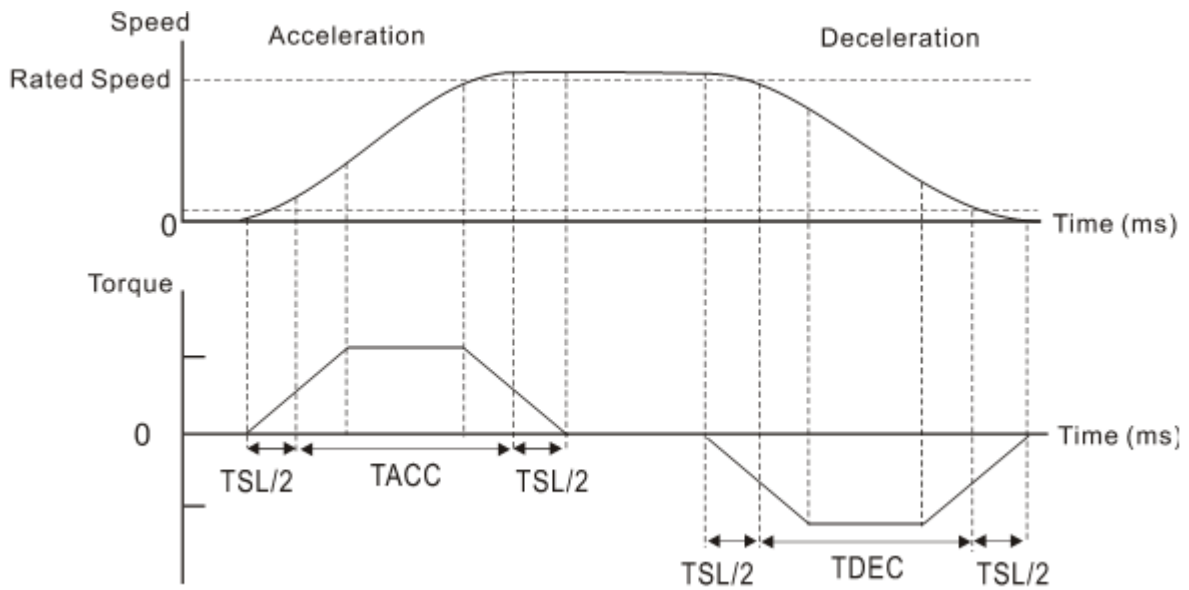

The relation between S-curve and time setting

Related parameters: Please refer to Chapter 8 for further information.

Parameter	Abbr.	Function
P1-34	TACC	Acceleration Constant of S-Curve
P1-35	TDEC	Deceleration Constant of S-Curve
P1-36	TSL	Acceleration / Deceleration Constant of S-Curve

Analog Speed Command Filter

Analog speed command filter is provided especially for ASDA-A2R series users. It mainly helps with buffer when the analog input signal changes too fast.

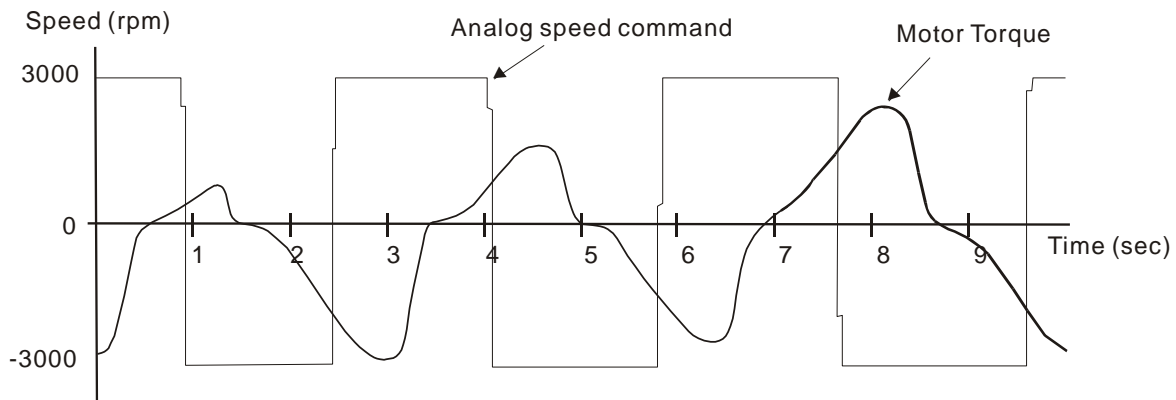

Analog speed command filter smooths the analog input command. Its time program is the same as S-curve filter in normal speed. Also, the speed curve and the acceleration curve are both continuous. The above is the diagram of analog speed command filter. The slope of speed command in acceleration and deceleration is different. Users could adjust the time setting (P1-34, P1-35 and P1-36) according to the actual situation to improve the performance.

Command end low-pass filter

It is usually used to eliminate the unwanted high-frequency response or noise. It also can smooth the command.

Related parameter: Please refer to Chapter 8 for further information.

Parameter	Abbr.	Function
P1-06	SFLT	Analog Speed Command (Low-pass Filter)

6.3.4 The Scaling of Analog Command

The motor speed command is controlled by the analog voltage deviation between V_REF and VGND. Use parameter P1-40 to adjust the speed-control slope and its range.

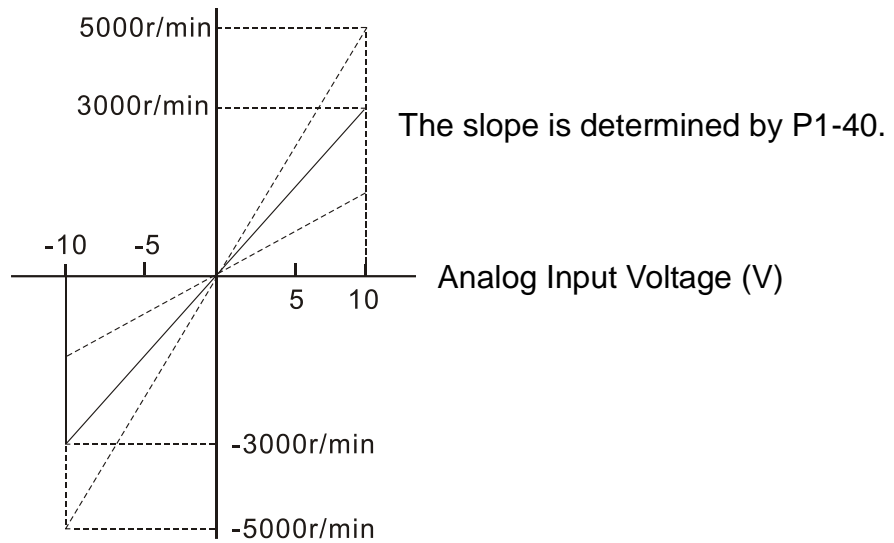

Related parameter: Please refer to Chapter 8 for further information.

Parameter	Abbr.	Function	Setting
P1-40	VCM	Maximum Speed of Analog Speed Command	Set P1-40 to 2000. If the input voltage is 10V, the speed command will be 2000r/min.

6.3.5 The Timing Diagram in Speed Mode

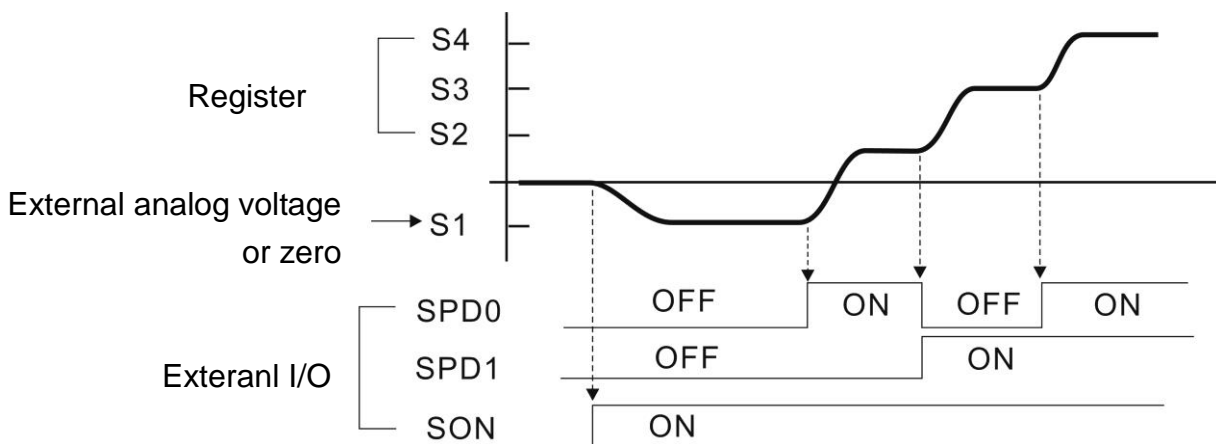

Note:

- 1) OFF means the contact point is open while ON means the contact point is close.
- 2) When it is in Sz mode, the speed command S1 = 0; When it is in S mode, the speed command S1 is the external analog voltage input.
- 3) When the servo drive is On, please select the command according to SPD0~SPD1 status.

6.3.6 Gain Adjustment of Speed Loop

Here introduces the function of speed control unit. The following shows its structure.

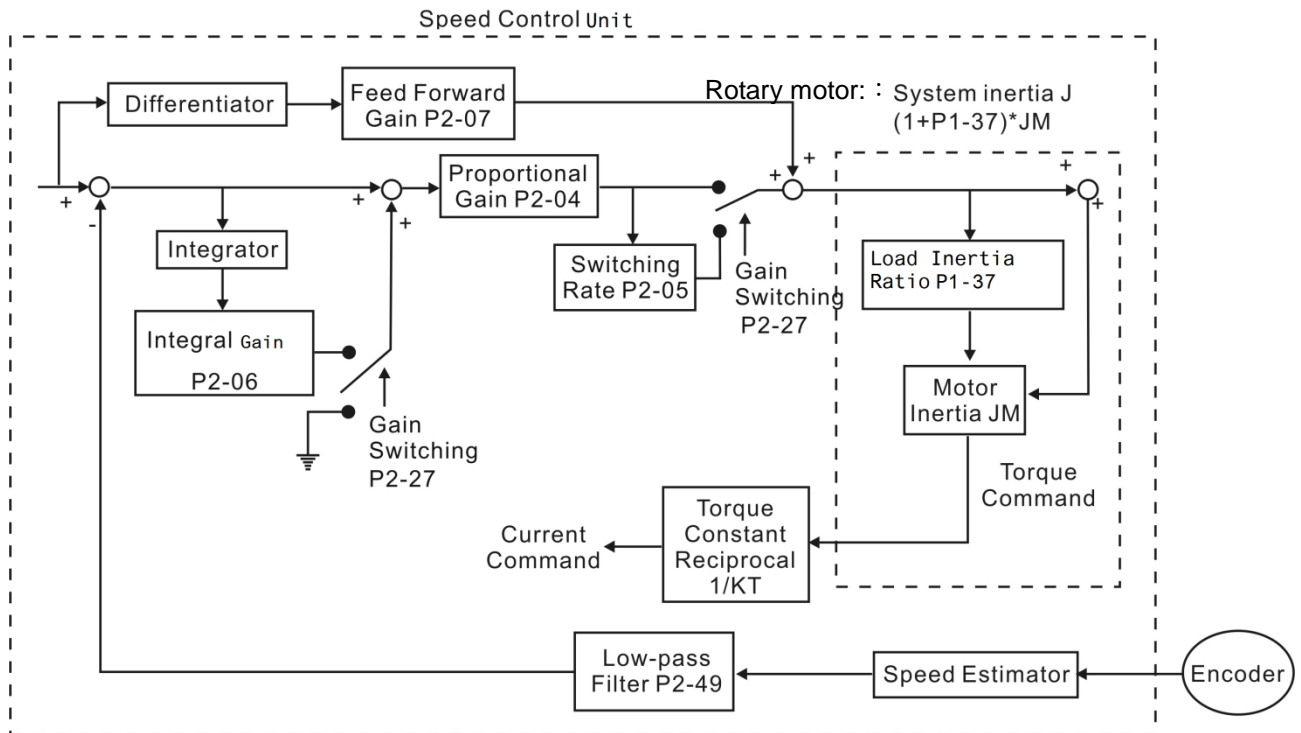

※Inertia ratio is for rotary motor; while total weight of movable section and load is for linear motor.

Many kinds of gain in speed control unit are adjustable. Two ways, manual and auto, are provided for selection.

Manual: All parameters are set by users and the auto or auxiliary function will be disabled in this mode.

Auto: General load inertia estimation is provided. It adjusts the parameter automatically. Its framework is divided into PI auto gain adjustment and PDFF auto gain adjustment.

Related parameter: Please refer to Chapter 8 for further information.

Parameter P2-32 can be used to adjust the gain.

Parameter	Abbr.	Function
P2-32	AUT2	Tuning Mode Selection

Manual Mode

When P2-32 is set to 0, users can define Speed Loop Gain (P2-04), Speed Integral Compensation (P2-06) and Speed Feed Forward Gain (P2-07). Influence of each parameter is as the followings.

Proportional gain: To increase proportional gain can enhance the response frequency of speed loop.

Integral gain: To increase the integral gain could increase the low-frequency stiffness of speed loop, reduce the steady-state error and sacrifice the phase margin.
The over high integral gain will cause the instability of the system.

Feed forward gain: Diminish the deviation of phase delay.

Related parameters: Please refer to Chapter 8 for further information.

Parameter	Abbr.	Function
P2-04	KVP	Speed Loop Gain
P2-06	KVI	Speed Integral Compensation
P2-07	KVF	Speed Feed Forward Gain

Theoretically, stepping response can be used to explain proportional gain (KVP), integral gain (KVI) and feed forward gain (KVF). Here, the frequency domain and time domain are used to illustrate the basic principle.

Frequency Domain

STEP 1: Set the value of $KVI=0$, the value of $KVF=0$ and adjust the value of KVP .

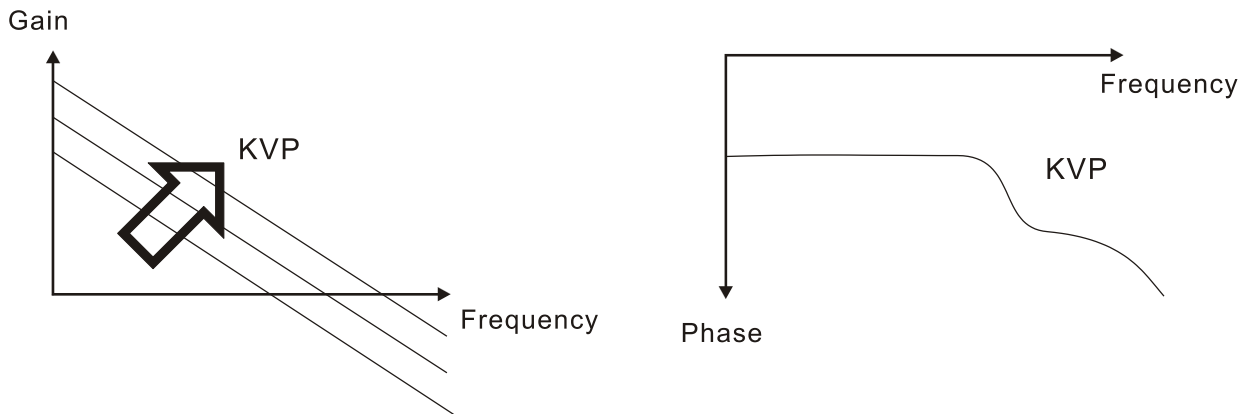

STEP 2 : The value of KVP remains and adjust the value of KVI .

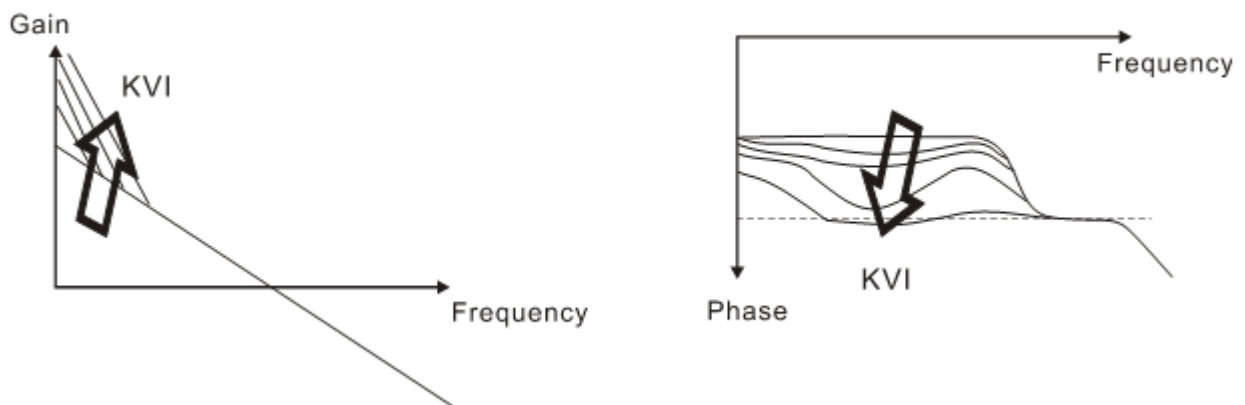

STEP 3:
 Select the value of KVI . If the value of the margin phase is too small, re-adjust the value of KVP so as to obtain the value of margin phase, 45deg.

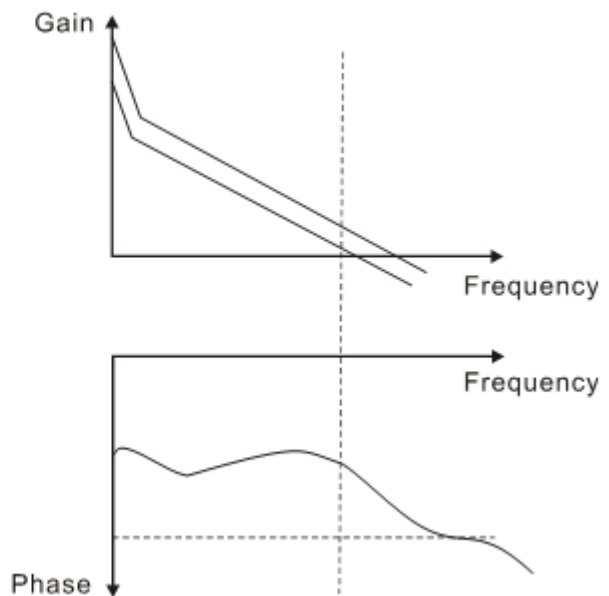

Time Domain

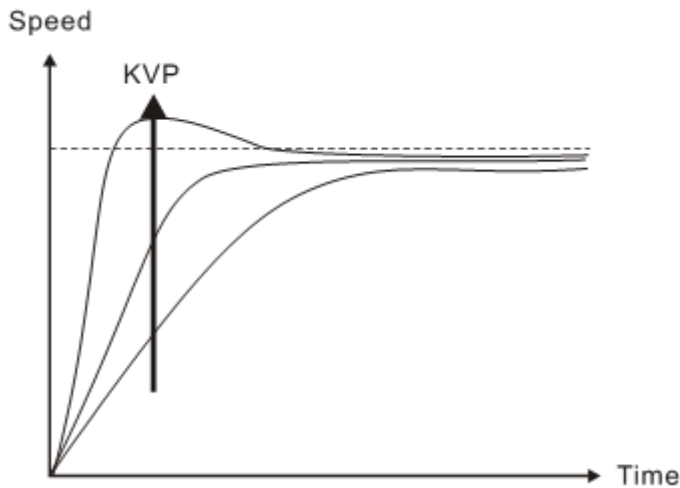

The bigger KVP value cause higher bandwidth and shorten the rising time. However, if the value is set too big, the phase margin will be too small.

To steady-state error, the result is not as good as KVI. But it helps to reduce the dynamic following error.

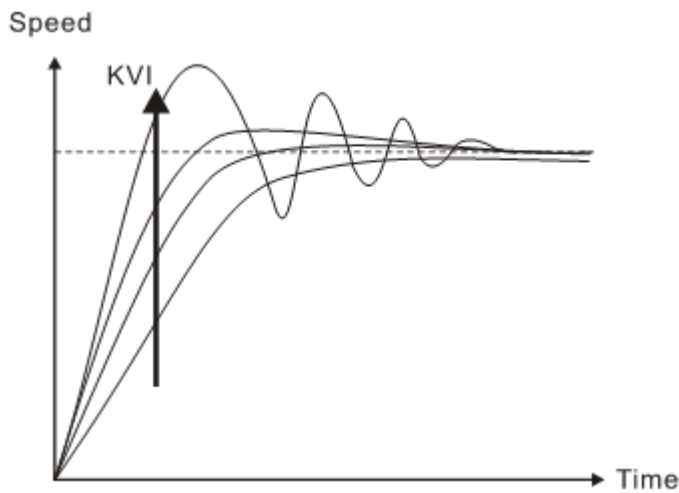

The bigger KVI value cause greater low-frequency gain and shorten the time the steady-state error returns to zero. However, the phase margin will dramatically decrease as well.

To steady-state error, it is very helpful but shows no benefit to dynamic following error.

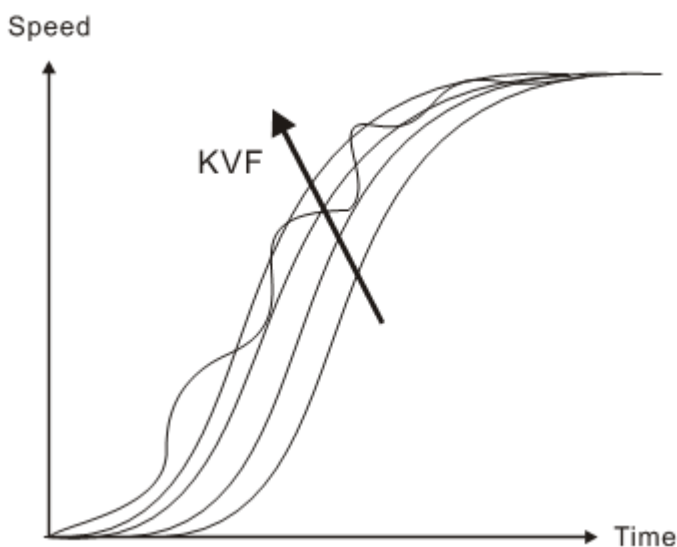

If the KVF value closes to 1, the feed forward compensation will be more complete and the dynamic following error will become smaller. However, if the KVF value is set too big, it would cause vibration.

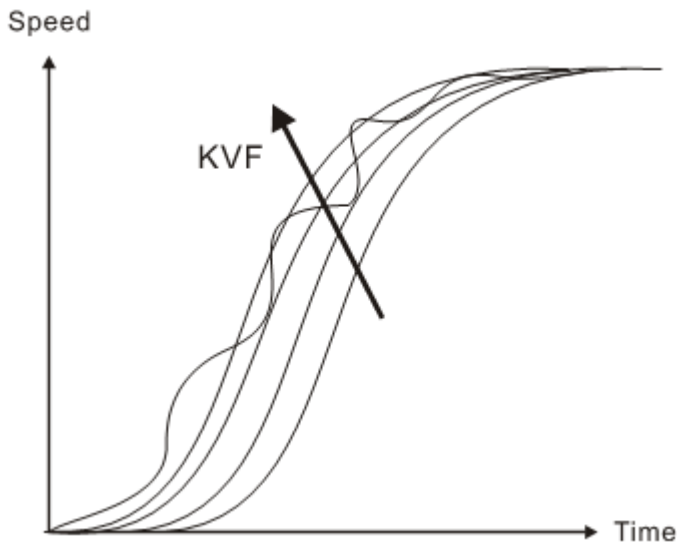

If the KVF value closes to 1, the feed forward compensation will be more complete and the dynamic following error will become smaller. However, if the KVF value is set too big, it would cause vibration.

Generally, instrument is needed when applying frequency domain for measurement. Users are required to adopt the measurement techniques; while time domain only needs a scope and goes with the analog input / output terminal provided by the servo drive. Thus, time domain is frequently used to adjust PI controller. The abilities of PI controller to deal with the resistance of torque (force) load and the following command are the same. That is to say, the following command and resistance of torque load have the same performance in frequency domain and time domain. Users can reduce the bandwidth by setting the low-pass filter in command end.

Auto Mode

Auto mode adopts adaptive principle. The servo drive automatically adjusts the parameters according to the external load. Since the adaptive principle takes longer time, it will be unsuitable if the load changes too fast. It would be better to wait until the load inertia is steady or changes slowly. Depending on the speed of signal input, the adaptive time will be different from one another.

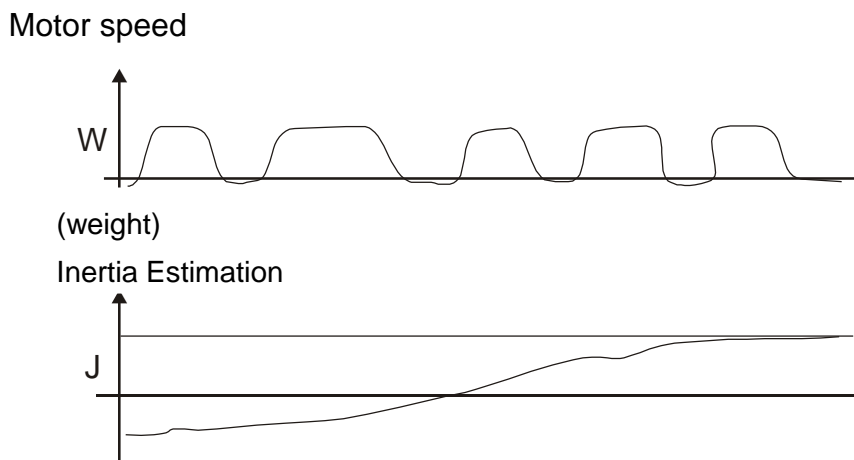

6.3.7 Resonance Suppression

When resonance occurs, it is probably because the stiffness of the control system is too strong or the response is too fast. Eliminating these two factors might improve the situation. In addition, low-pass filter (parameter P2-25) and notch filter (parameter P2-23 and P2-24) are provided to suppress the resonance if not changing the control parameters.

Related parameters: Please refer to Chapter 8 for further information.

Parameter	Abbr.	Function
P2-23	NCF1	Resonance Suppression (Notch filter) (1)
P2-24	DPH1	Resonance Suppression (Notch filter) Attenuation Rate (1)
P2-25	NLP	Low-pass Filter of Resonance Suppression
P2-43	NCF2	Resonance Suppression (Notch filter) (2)
P2-44	DPH2	Resonance Suppression (Notch filter) Attenuation Rate (2)
P2-45	NCF3	Resonance Suppression (Notch filter) (3)
P2-46	DPH3	Resonance Suppression (Notch filter) Attenuation Rate (3)

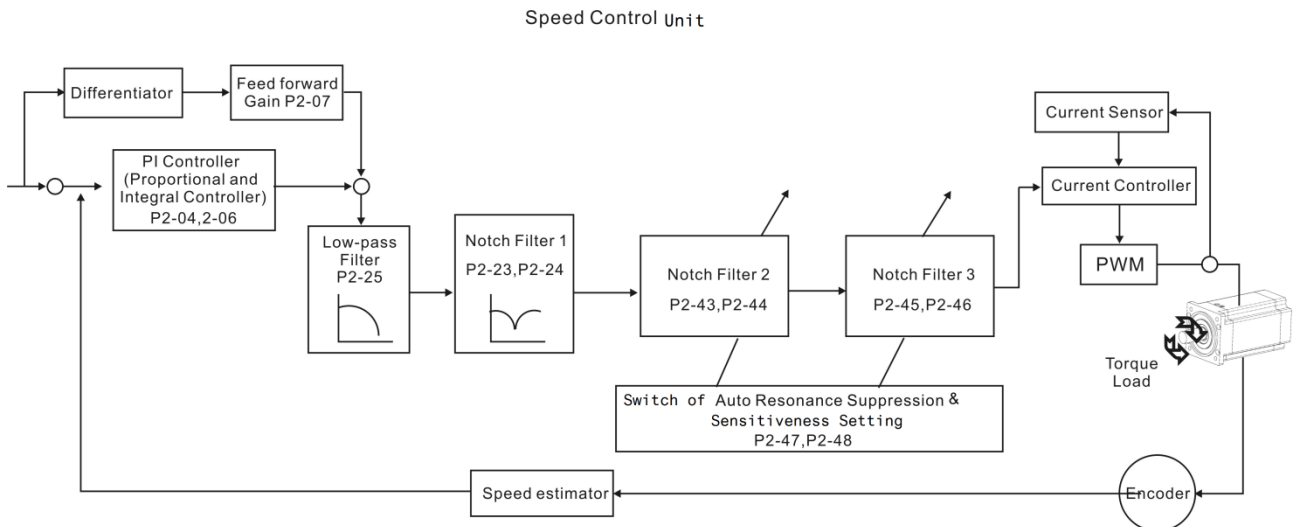

There are two sets of auto resonance suppression, one is P2-43 and P2-44 and another one is P2-45 and P2-46. When the resonance occurs, set P2-47 to 1 or 2 (enable the function of resonance suppression), the servo drive searches the point of resonance frequency and suppresses the resonance automatically. Write the point of frequency into P2-43 and P2-45 and write the attenuation rate into P2-44 and P2-46. When P2-47 is set to 1, the system will set P2-47 to 0 (disable the function of auto suppression) automatically after completing resonance suppression and the system is stable for 20 minutes. When P2-47 is set to 2, the system will keep searching the point of resonance.

When P2-47 is set to 1 or 2, but resonance still exists, please confirm the value of parameter P2-44 and P2-46. If one of them is 32, it is suggested to reduce the speed bandwidth first and then start to estimate again. If the value of both is smaller than 32 and resonance still exists, please set P2-47 to 0 first and then manually increase the value of

P2-44 and P2-46. It is suggested to reduce the bandwidth if the resonance has not been improved. Then use the function of auto resonance suppression.

When manually increase the value of P2-44 and P2-46, please check if the value of both is bigger than 0. If yes, it means the frequency point of P2-43 and P2-45 is the one searched by auto resonance suppression. If the value of both is 0, it means the default, 1000 of P2-43 and P2-45 is not the one searched by auto resonance suppression. Deepen the resonance suppression attenuation rate might worsen the situation.

P2-47 Function Table		
P2-47 Current Value	P2-47 Desire Value	Function
0	1	Clear the value of P2-43~P2-46 and enable the function of auto resonance suppression.
0	2	Clear the value of P2-43~P2-46 and enable the function of auto resonance suppression.
1	0	Save the current value of P2-43~P2-46 and disable the function of auto resonance suppression.
1	1	Clear the value of P2-43~P2-46 and enable the function of auto resonance suppression.
1	2	Not clear the value of P2-43~P2-46 and continue to enable the function of auto resonance suppression.
2	0	Save the current value of P2-43~P2-46 and disable the function of auto resonance suppression.
2	1	Clear the value of P2-43~P2-46 and enable the function of auto resonance suppression.
2	2	Not clear the value of P2-43~P2-46 and continue to enable the function of auto resonance suppression.

Flowchart of Auto Resonance Suppression:

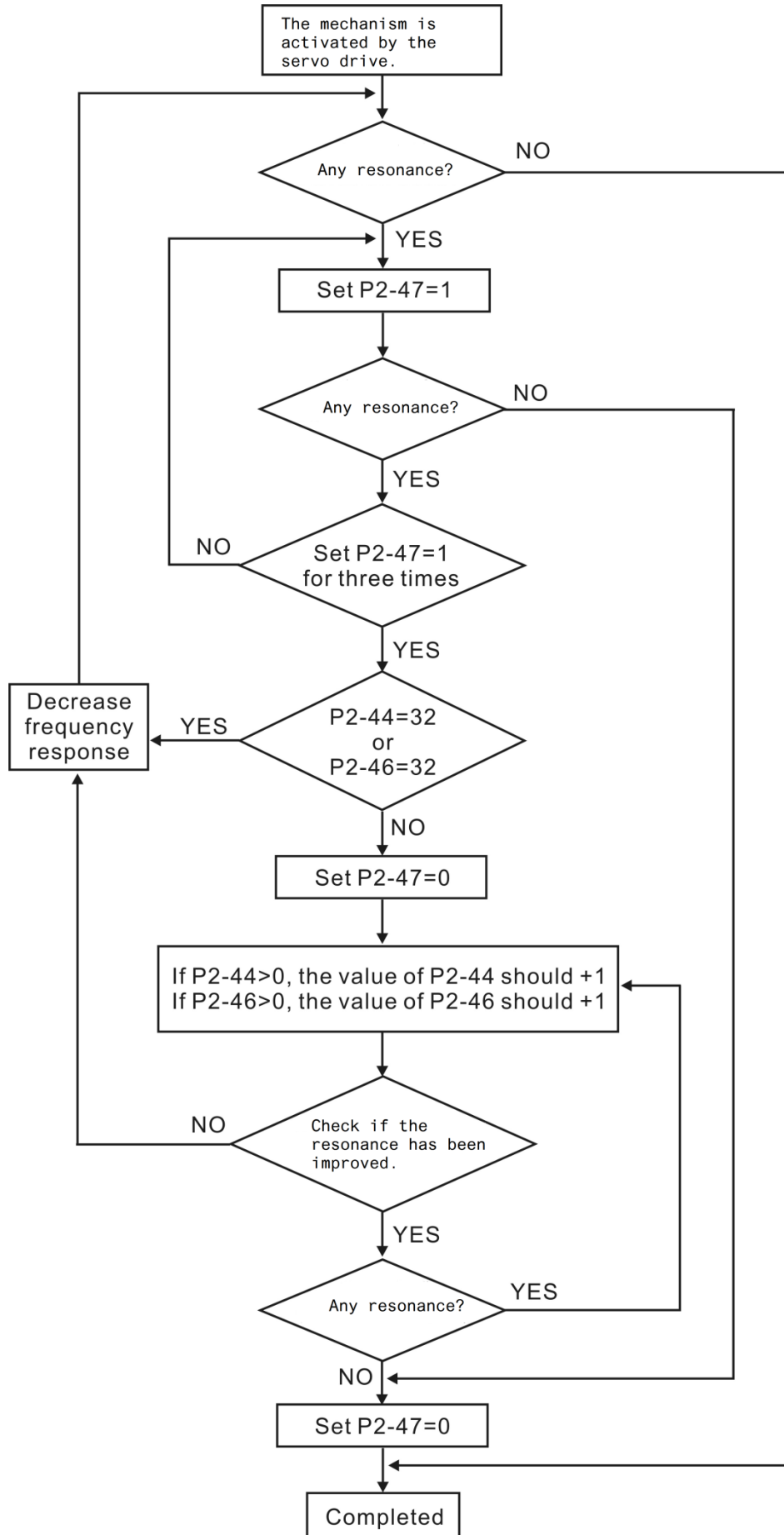

Here illustrates the effect via low-pass filter (parameter P2-25). The following diagram is the system open-loop gain with resonance.

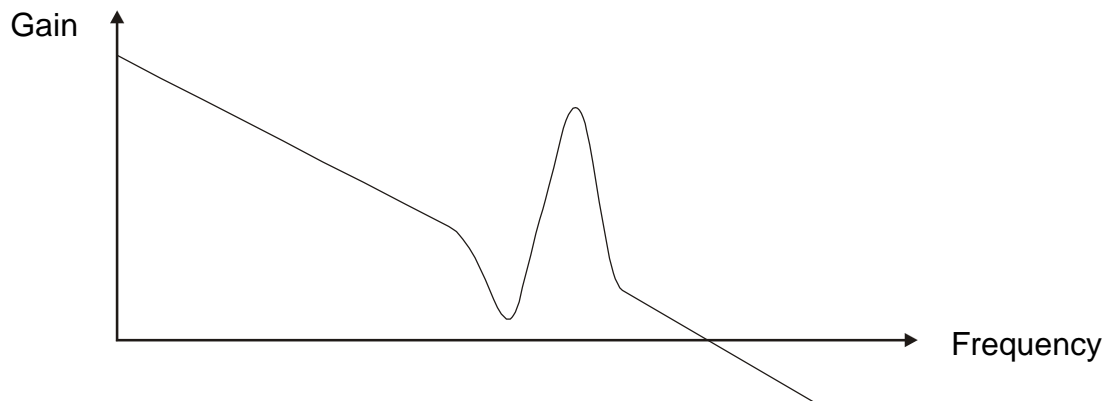

When the value of P2-25 is increased from 0, BW becomes smaller (See as the following diagram). Although it solves the problem of resonance frequency, the response bandwidth and phase margin is reduced.

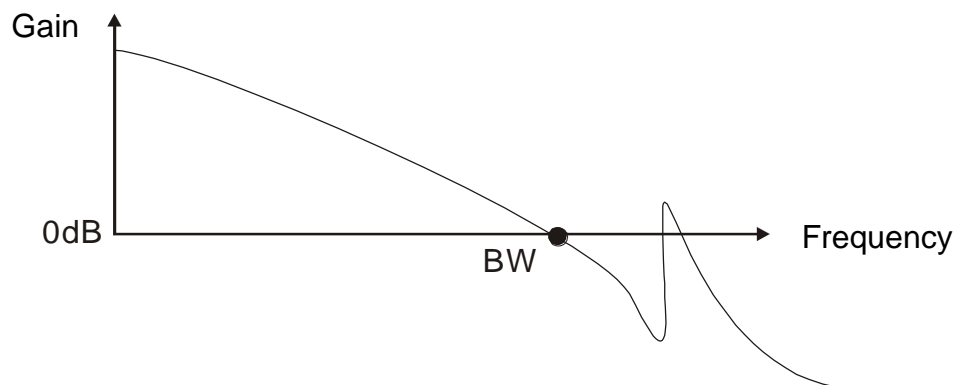

If users know the resonance frequency, notch filter (parameter P2-23 and P2-24) can directly eliminate the resonance. The frequency setting range of notch filter is merely from 50 to 1000Hz. The suppression strength is increased from 0 to 32dB. If the resonance frequency is not within the range, it is suggested to use low-pass filter (parameter P2-25).

Here firstly illustrates the influence brought by notch filter (P2-23 and P2-24) and low-pass filter (P2-25). The following diagrams are the system of open-loop gain with resonance.

Resonance suppression with notch filter

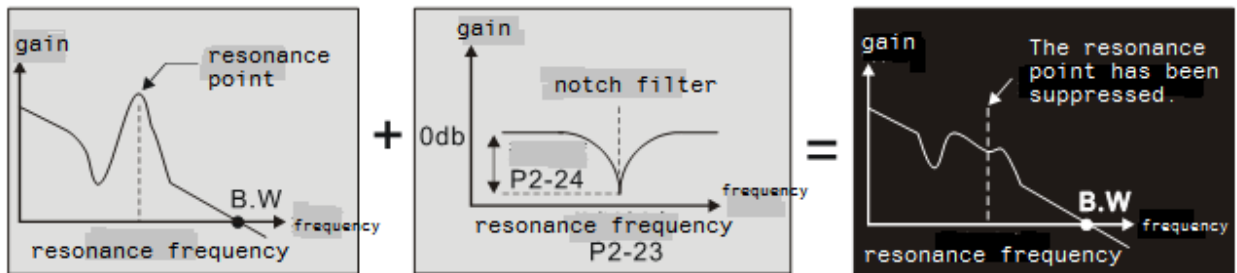

Resonance suppression with low-pass filter

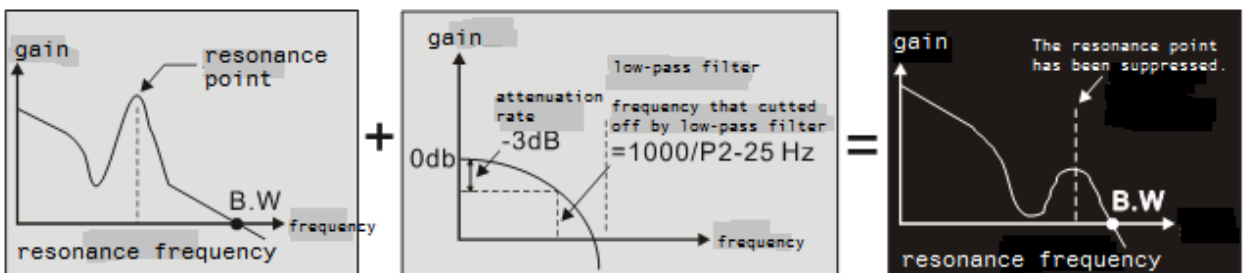

When the value of P2-25 is increased from 0, BW becomes smaller. Although it solves the problem of resonance frequency, the response bandwidth and phase margin is reduced. Also, the system becomes unstable.

If users know the resonance frequency, notch filter (parameter P2-23 and P2-24) can directly eliminate the resonance. In this case, notch filter will be more helpful than low-pass filter. However, if the resonance frequency drifts because of time or other factors, notch filter will not do.

6.4 Torque (force) Mode

Torque (force) control mode (T or Tz) is appropriate in torque (force) control application, such as printing machine, winding machine, etc. There are two kinds of command source, analog input and register. Analog command input uses external voltage to control the torque (force) of the motor while register uses the internal parameters (P1-12~P1-14) as the torque (force) command.

6.4.1 Selection of Torque (force) Command

Torque (force) command source are external analog voltage and parameters. It uses CN1 DI signal for selection. See as below.

Torque Command No.	CN1 DI Signal		Command Source		Content	Range
	TCM1	TCM0				
T1	0	0	Mode	T	External analog command	Voltage deviation between T-REF and GND -10 V ~ +10V
				Tz	N/A	Torque (force) command is 0 0
T2	0	1	Parameters		P1-12	-300% ~ 300%
T3	1	0			P1-13	-300% ~ 300%
T4	1	1			P1-14	-300% ~ 300%

- The status of TCM0 ~ TCM1: 0 means DI OFF and 1 means DI ON.
- When TCM0 = TCM1 = 0, if it is in Tz mode, then the command is 0. Thus, if there is no need to use analog voltage as torque (force) command, Tz mode is applicable and can avoid the problem of zero drift. If it is in T mode, the command will be the voltage deviation between T-REF and GND. Its input voltage range is -10V ~ +10V, which means the corresponding torque (force) is adjustable (P1-41).
- When neither TCM0 nor TCM1 is 0, parameters become the source of torque (force) command. The command will be executed after TCM0 ~ TCM1 are changed. There is no need to use CTRG for triggering.

The torque (force) command can be used in torque (force) mode (T or Tz) and speed mode (S or Sz). When it is in speed mode, it can be regarded as the command input of torque (force) limit.

6.4.2 Control Structure of Torque (force) Mode

The basic control structure is as the following diagram:



The torque (force) command unit is to select torque (force) command source according to Section 6.4.1, including the scaling (P1-41) setting and S-curve setting. The current control unit manages the gain parameters of the servo drive and calculates the current for servo motor in time. Since the current control unit is very complicated, and is not relevant to the application. There is no need to adjust parameters. Only command end setting is provided.

The structure of torque (force) command unit is as the following diagram.

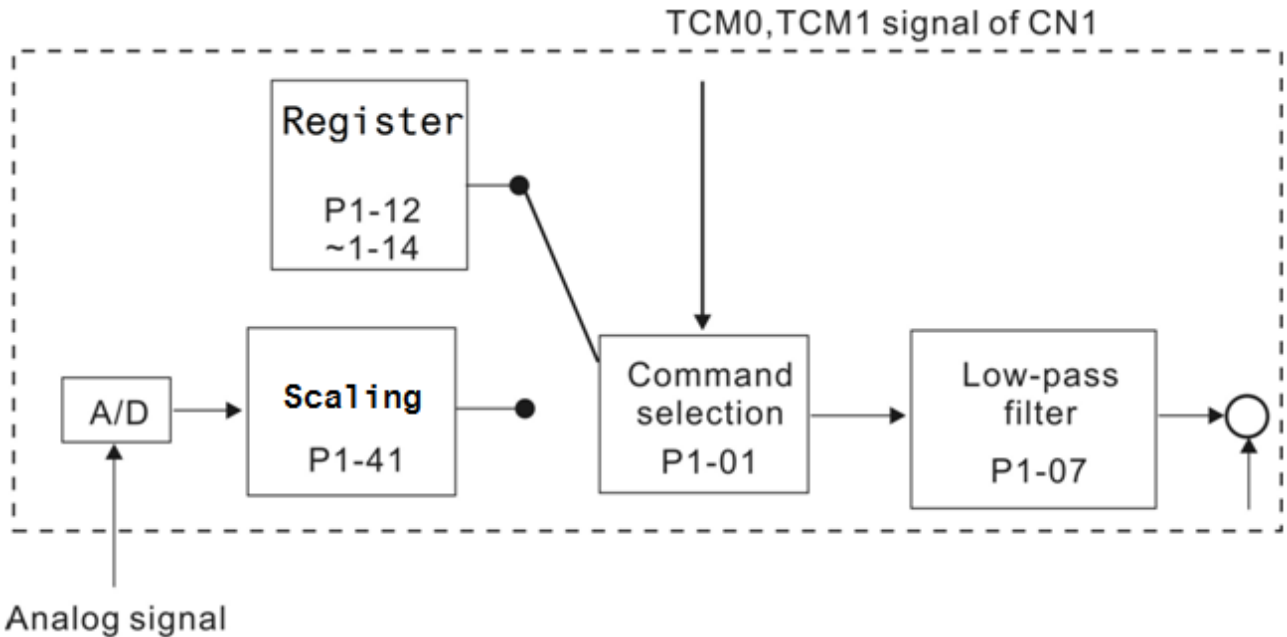

The upper path is the command from register while the lower one is external analog command. The command is selected according to the status of TCM0, TCM1 and P1-01 (T or Tz). The torque (force) represented by analog voltage command can be adjusted via the scaling and can obtain a smoother response via low-pass filter.

6.4.3 Smooth Torque (force) Command

Related parameter: Please refer to Chapter 8 for further information.

Parameter	Abbr.	Function
P1-07	TFLT	Analog Torque (force) Command (Low-pass Filter)

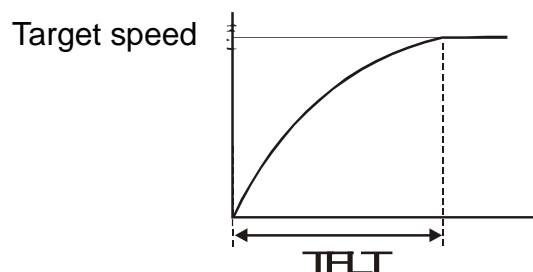

6.4.4 The Scaling of Analog Command

The motor torque command is controlled by the analog voltage deviation between T_REF and GND and goes with parameter P1-41 to adjust the torque slope and its range.

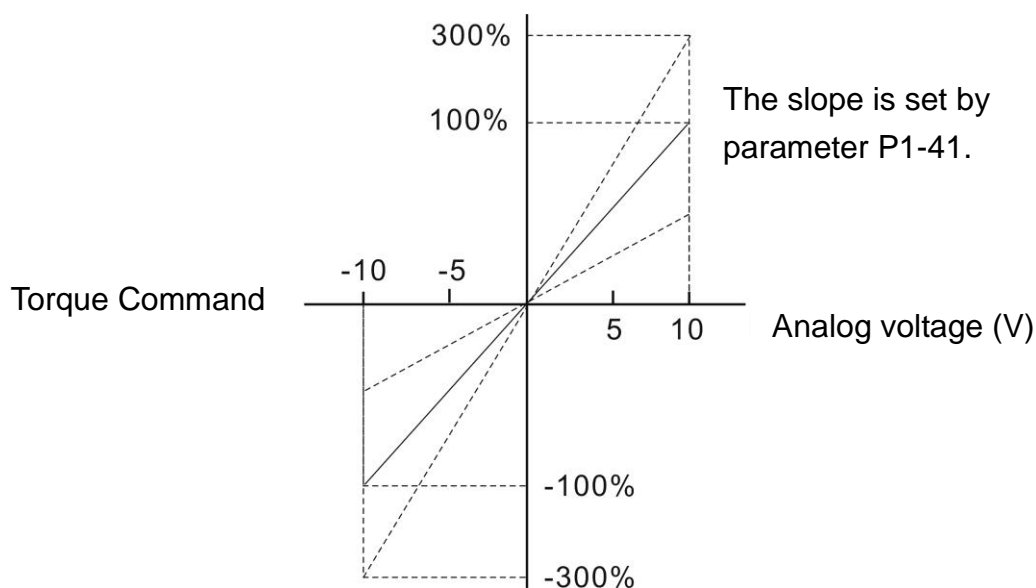

Related parameter: Please refer to Chapter 8 for further information.

Parameter	Abbr.	Function	Setting
P1-41	TCM	Maximum Output of Analog Torque (force) Speed	Set P1-41 to 100. Then, the input voltage 10V corresponds to 100% of rated torque.

6.4.5 The Timing Diagram in Torque (force) Mode

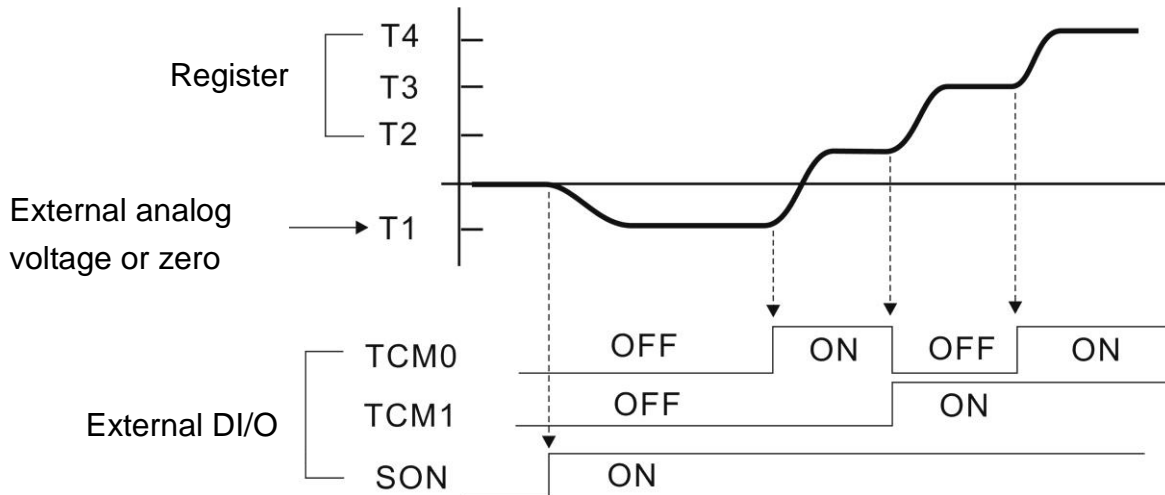

Note:

- 1) OFF means the contact point is open while ON means the contact point is close.
- 2) When it is in Tz mode, the torque (force) command T1 = 0; When it is in T mode, the torque (force) command T1 is the external analog voltage input.
- 3) When the servo drive is Servo On, please select the command according to TCM0~TCM1 status.

6.5 Dual Mode

Apart from single mode, dual mode is also provided for operation. According to Section 6.1, dual modes are as followings:

- 1) Speed/position dual mode (PT-S, PR-S, PT-PR)
- 2) Speed/torque (force) dual mode (S-T)
- 3) Torque (force)/position dual mode (PT-T, PR-T)
- 4) Position speed multi mode (PT-PR-S)
- 5) Position torque (force) multi mode (PT-PR-T)

Mode Name	Short Name	Setting Code	Description
Dual Mode	PT-S	06	PT and S can be switched via DI signal, S_P .
	PT-T	07	PT and T can be switched via DI signal, T_P .
	PR-S	08	PR and S can be switched via DI signal, S_P .
	PR-T	09	PR and T can be switched via DI signal, T_P .
	S-T	0A	S and T can be switched via DI signal, S_T .
	PT-PR	0D	PT and PR can be switched via DI signal, PT_PR .
Multi Mode	PT-PR-S	0E	PT , PR and S can be switched via DI signal, S_P and PT_PR .
	PT-PR-T	0F	PT , PR and T can be switched via DI signal, T_P and PT_PR .

Sz and Tz dual mode is not provided here. For avoiding occupying too many digital inputs in dual mode, speed and torque (force) mode can use external analog voltage as the command source so as to reduce digital input (SPD0, SPD1 or TCM0, TCM1). Position mode could use input pulse of PT mode to save the use of DI (POS0, 1, 2, 3, 4, 5). Please refer to Chapter 3.3.2, table 3.1, Default Value of DI Input Function and table 3.2, Default Value of DO Output Function for the default DI/DO of each mode.

The relationship between DI/DO signals and PIN define are set after the mode is selected. If users desire to change the setting, please refer to Chapter 3.3.4.

6.5.1 Speed / Position Dual Mode

There are PT-S and PR-S in speed/position dual mode. The command source of the former one comes from external pulse while the latter one comes from internal parameters (P6-00~P7-27). Speed command could be issued by external analog voltage or internal parameters (P1-09~P1-11). The switch of speed/position mode is controlled by S-P signal and the switch of PR-S mode is controlled by DI signal, which is more complicated. The timing diagram is shown as below.

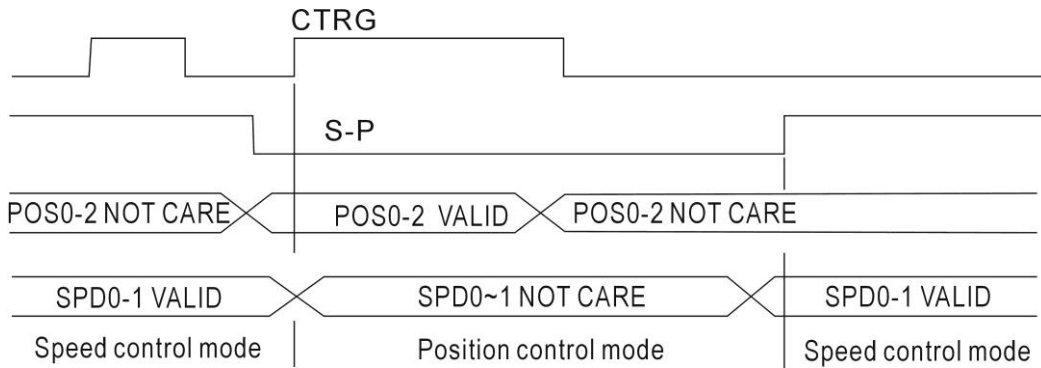

Diagram 1: Dual control mode of speed and position

In speed mode (S-P is ON), the speed command is selected via SPD0 and SPD1. CTRG is not working at the moment. When switching to position mode (S-P is OFF), since position command has not been issued (needs to wait the rising edge of CTRG), the motor stops. The position command is determined by POS0~POS5 and triggered by rising edge of CTRG. When S-P is ON, it goes back to speed mode again. Please refer to the introduction of single mode for DI signal and the selected command of each mode.

6.5.2 Speed / Torque (force) Dual Mode

S-T is the only mode. The speed command comes from the external analog voltage and internal parameters (P1-09 ~P1-11), which is selected via SPD0~SPD1. Similarly, the source of torque (force) command could be external analog voltage and internal parameters (P1-12 ~ P1-14) and is selected via TCM0~TCM1. The switch of speed/torque (force) mode is controlled by S-T signal. The timing diagram is shown as below.

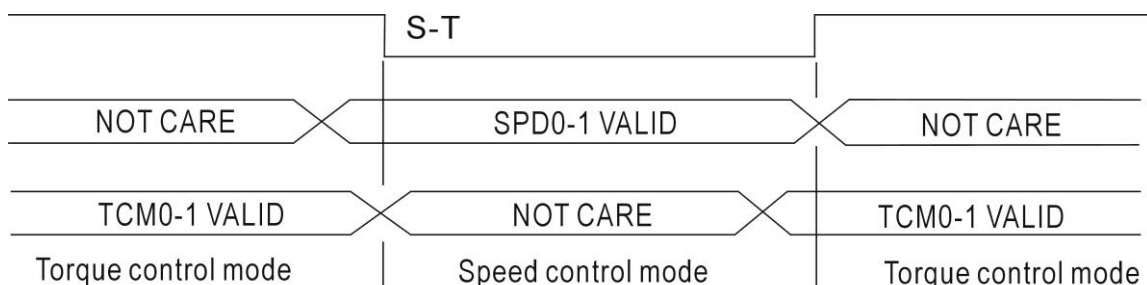

Diagram 2: Dual control mode of speed and torque

In torque (force) mode (S-T is ON), the torque (force) command is selected via TCM0 and TCM1. When switching to speed mode (S-T is OFF), the torque (force) command is selected via SPD0 and SPD1. The motor operates according to the speed command.

When S-T is ON, it goes back to the torque (force) mode again. Please refer to the introduction of single mode for DI signal and the selected command of each mode.

6.5.3 Torque (force) / Position Dual Mode

There are PT-T and PR-T. The command source of the former one comes from external pulse while the latter one comes from internal parameters (P6-00~P7-27). Torque (force) command could be issued by external analog voltage or internal parameters (P1-12~P1-14). The switch of torque (force)/position mode is controlled by T-P signal and the switch of PR-T mode is controlled by DI signal, which is more complicated. The timing diagram is shown as below.

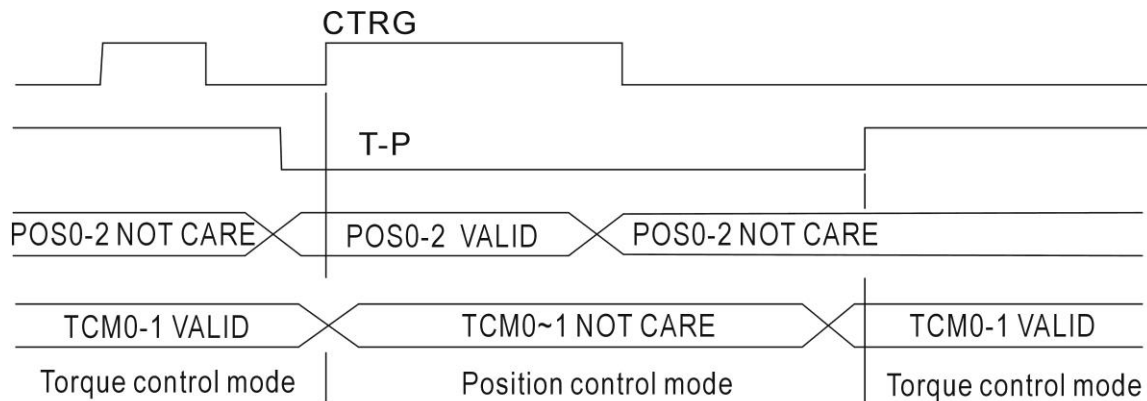

Diagram 3: Dual control mode of torque and position

In torque (force) mode (T-P is ON), the torque (force) command is selected via TCM0 and TCM1. CTRG is not working at the moment. When switching to position mode (T-P is OFF), since position command has not been issued (needs to wait the rising edge of CTRG), the motor stops. The position command is determined by POS0~POS5 and triggered by rising edge of CTRG. When T-P is ON, it goes back to torque (force) mode again. Please refer to the introduction of single mode for DI signal and the selected command of each mode.

6.6 Others

6.6.1 The Use of Speed Limit

The maximum speed in each mode is limited by internal parameters (P1-55), no matter it is in position, speed or torque (force) mode.

The issuing method of speed limit command and speed command is the same. The command source could be external analog voltage or internal parameter (P1-09 ~ P1-11). Please refer to Section 6.3.1 for descriptions.

Speed limit can be used in torque (force) mode (T) only. It is used for limiting the motor speed. When the command in torque (force) mode is issued by external analog voltage, DI signal is enough and can be regarded as SPD0~SPD1 which is used to determine the speed limit command (internal parameters). If the DI signal is not enough, speed limit command can be issued by analog voltage. When the function of disable/enable limit function in P1-02 is set to 1, the speed limit function is enabled. See the timing diagram as below.

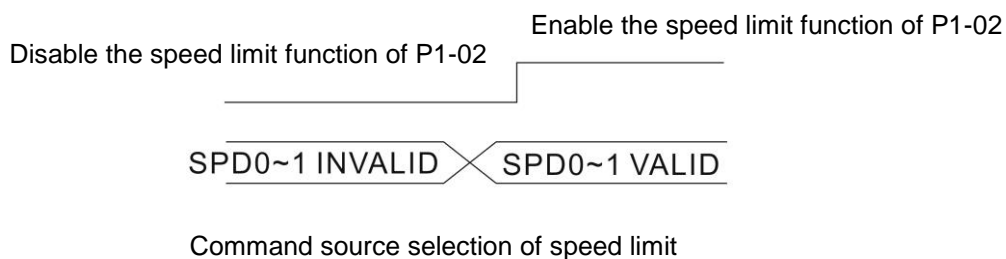

6.6.2 The Use of Torque (force) Limit

The issuing method of torque (force) limit command and torque (force) command is the same. The command source could be external analog voltage or internal parameter (P1-12 ~ P1-14). Please refer to Chapter 6.4.1 for descriptions.

Torque (force) limit can be used in position mode (PT, PR) or speed mode (S). It is used for limiting the motor torque (force) output. When the command in position mode is issued by external analog voltage, DI signal is enough and can be regarded as TCM0~TCM1, which is used to determine torque (force) limit command (internal parameters). If the DI signal is not enough, torque (force) limit command can be issued by analog voltage. When the function of disable/enable torque (force) limit function in P1-02 is set to 1, the torque (force) limit function is enabled. See the timing diagram as below.

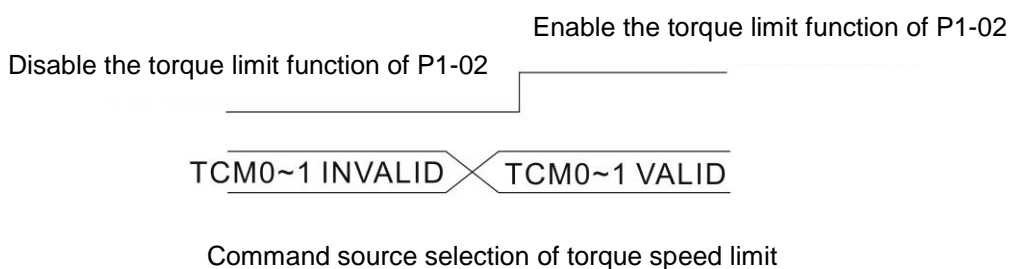

6.6.3 Analog Monitor

Users could observe the needed voltage signal via analog monitor. Two analog channels are provided by the servo drive and locate in terminal 15 and 16 of CN1.

Related parameter: Please refer to Chapter 8 for further information.

Parameter	Abbr.	Function
P0-03	MON	Analog Output Monitor
P1-03	AOUT	Polarity Setting of Encoder Pulse Output
P1-04	MON1	MON1 Analog Monitor Output Proportion
P1-05	MON2	MON2 Analog Monitor Output Proportion
P4-20	DOF1	Offset Adjustment Value of Analog Monitor Output (Ch1)
P4-21	DOF2	Offset Adjustment Value of Analog Monitor Output (Ch2)

For example, when users desire to observe the voltage signal of channel 1, if the monitor output voltage is 8 V per 2.25 M, then the setting value of P1-04 should be changed to 50 ($= 2.25 \text{ M}/\text{max. input frequency}$). Other related setting includes P0-03 ($X = 3$), P1-03 (Polarity Setting of Encoder Pulse Output, range from 0 to 3, to setup positive / negative output); In general, when the output voltage value of Ch1 is V_1 , the pulse command frequency is equal to $(\text{Max. input frequency} \times V_1/8) \times P1-04/100$.

Since there is an offset value of analog monitor output voltage, the zero voltage level of analog monitor output does not match to the zero point of setting value. It is recommended to use Offset Adjustment Value of Analog Monitor Output, DOF1 (P4-20 and DOF2 (P4-21) to improve it. The max. output voltage is $\pm 8\text{V}$, if the voltage exceeds the range, it will be limited within the range of $\pm 8\text{V}$. The revolution of ASDA-A2R is 10bits, which approximates to 13mV/LSB.

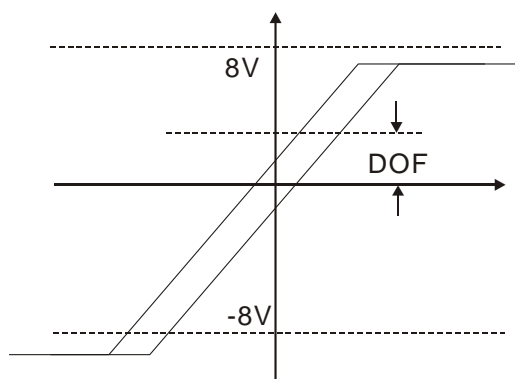

6.6.4 The Use of Brake

When operating brake via servo drive, if the DO signal, BRKR is set to OFF, it means the brake is not working and the motor will be locked. If BRKR is set to ON, it means the brake is working and the motor can operate. The operation of brake has two kinds. Users can set the relevant delay via register MBT1 (P1-42) and MBT2 (P1-43). It is usually applied in Z axis in order to reduce the heat generated when servo motor puts up resistance and shorten its lifetime. In order to avoid the error of brake, it must be worked when the servo drive is off. To operate the brake, the brake has to be activated before the motor stops running (Servo OFF). The brake has to be released after Servo ON. Otherwise, it would become the loading of the motor and might damage the brake.

If it works during the process of acceleration or constant speed, the servo drive needs to generate more current to resist the brakeforce of brake and it might cause the alarm of overload warning.

Timing diagram of brake control:

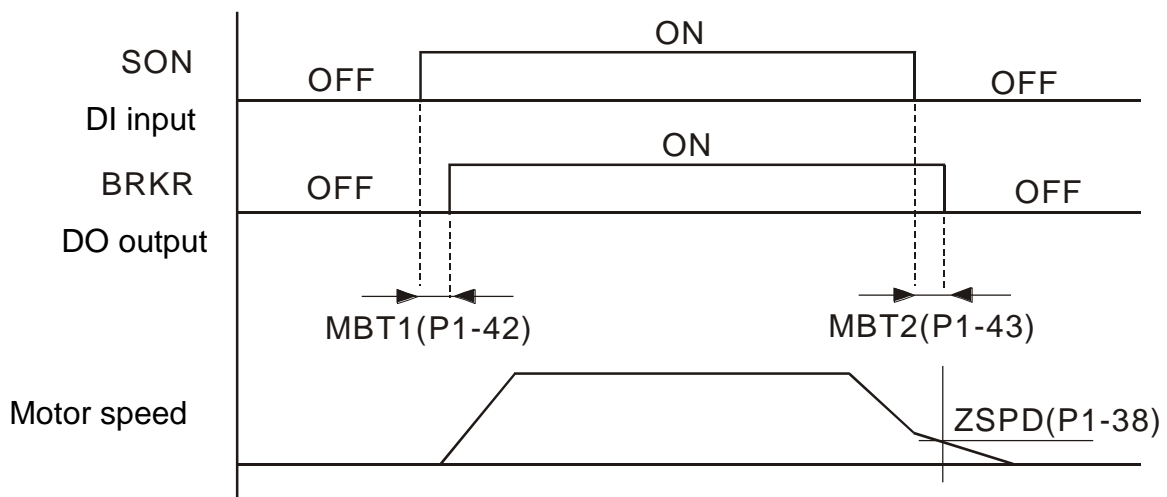

The output timing of BRKR:

1. When Servo OFF, go through the time set by P1-43 and the motor speed is faster than the setting in P1-38, DO.BRKR is OFF (the brake is locked).
2. When Servo OFF, has not reached the time set by P1-43 but the motor speed is slower than the setting in P1-38, DO.BRKR is OFF (the brake is locked).

The wiring diagram of using mechanical brake:

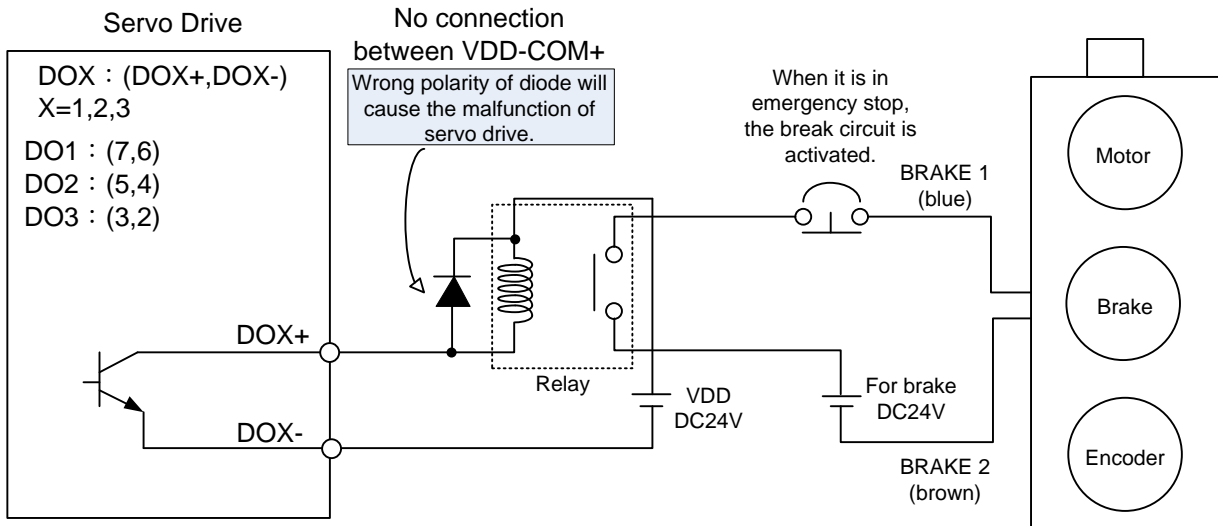

Note:

- 1) Please refer to Chapter 3, Wiring.
- 2) The brake signal controls the solenoid valve, provides power to the brake and enables the brake.
- 3) Please note that there is no polarity in coil brake.
- 4) Do not use brake power and control power (VDD) at the same time.

Timing diagram of control power and main power:

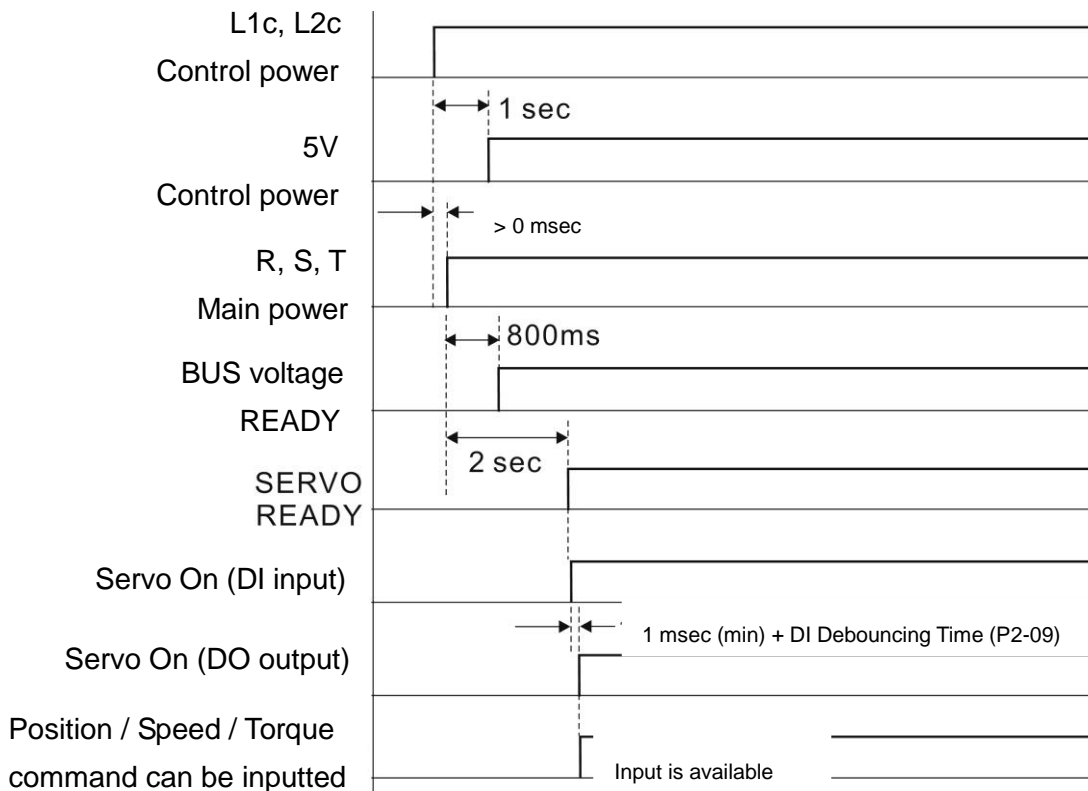

(This page is intentionally left blank.)

Chapter 7 Motion Control

7.1 Motion Control Functions of ASDA-A2R

- 1) Single-axis motion controller of PR (Procedure) control
- 2) Function of CAPTURE (data capture) / COMPARE (data compare)
- 3) Function of E-Cam

7.2 Information of the Servo Drive

The information of this servo drive can be divided into three parts: System parameters, Monitor variables and Data array.

Descriptions are as follows:

	System Parameters	Monitor Variables
Functional Description	It is used to be the reference mode, important data or operation condition when the servo drive is operating, e.g. Control Mode, Servo Loop Gain, etc.	The status of the servo drive or motor, e.g. motor position, speed, electric current, etc.
Display Format	Panel displays PX-XX. Pressing the SET Key to display parameters and start setting. Please refer to Chapter 4 for Panel Display and Operation.	Set P0-02 to Monitor variables code and enter into Monitor Mode. The panel will display the value of the variable. Or pressing the MODE Key on the panel to switch to Monitor Mode. Please refer to Chapter 4 for Panel Display and Operation.
Access Method	Readable and writable (depends on parameters)	Read-only
Data Size	16-bit or 32-bit (depends on parameters)	32-bit integers only
Communication	Access via MODBUS / CANopen / USB Each parameter occupies two MODBUS addresses	<ul style="list-style-type: none"> • It only can be monitored via PC software by connecting USB • It does not directly support MODBUS / CANopen access, unless mapping is for corresponding the specified monitor variables to system parameters.
Mapping Support	8 groups of parameter, P0-25 ~ P0-32 (set by P0-35 ~ P0-42)	5 groups of parameter, P0-09 ~ P0-13 (set by P0-17 ~ P0-21)

	System Parameters	Monitor Variables
Note		In Monitor Mode, pressing UP/DOWN Key on the panel to switch the commonly used monitor variables (code 0~26); however, it cannot display all (about 150 in total)

7.2.1 Description of Monitor Variables

Description of Monitor Variables:

Item	Descriptions
Variable Code	Each monitor variable has a code. Set the code via P0-02 so that the users can monitor the variable.
Format	Every monitor variable is saved with the format of 32-bit (long integer) in the servo drive.
Classification	It is divided into basic variables and extension variables: <ol style="list-style-type: none"> Basic variables: Use the Monitor Mode on the panel to find the variable (variables in the cycle) by pressing UP/ DOWN Key (P0-02 = 0~26) Extension variables: Variables other than the basic ones (P0-02 = 27~127)
Monitor Method	Two methods, Panel display and Mapping: <ol style="list-style-type: none"> Panel display: View through the panel directly Mapping: Correspond the variables to the system parameters and view the variables via parameters.
Panel Display	<ol style="list-style-type: none"> Switch to the Monitor Mode by pressing the MODE Key and select the desired monitoring variables via UP/DOWN Key. Directly enter the desired monitoring code via P0-02 for viewing. Pressing the SHF Key on the panel can switch the display of high / low word; Pressing the SET Key on the panel can switch the display of decimal / hexadecimal format.
Mapping	<ol style="list-style-type: none"> Mapping parameters that support monitor variable are P0-09 ~ P0-13. Please refer to Chapter 8.3 for parameter description. Monitor variables can be read via communication by mapping parameters. The value of mapping parameters (P0-09~P0-13) is the content of basic variables (17h, 18h, 19h, 1Ah). The setting value which is set by P0-17 should be monitored via p0-09 (refer to p0-02). When accessing data via communication, the value of P0-17 can be read or monitored via panel (Set P0-02 to 23). When the panel shows 「VAR-1」, it means it is the value of P0-09.

The descriptions of monitor variables attribute are as the following.

Attribute	Descriptions
B	BASE: basic variables. Variables that can be viewed by UP/DOWN Key on the panel.
Dn	When the panel displays, the position of the decimal point will be D1 which means it only shows one decimal point; D2 means it shows two decimal points.
Dec	When the panel displays, the information only can be shown in decimal format. Pressing the SET Key on the panel cannot switch it to hexadecimal format.
Hex	When the panel displays, the information only can be shown in hexadecimal format. Pressing the SET Key on the panel cannot switch it to decimal format.

Descriptions of monitor variables in sequence of code are as the following.

Code	Name of Variables / Attribute	Descriptions
000 (00h)	Feedback position (PUU) B	The current feedback position of the motor encoder. The unit is PUU (user unit).
001 (01h)	Position command (PUU) B	The current coordinate of position command. The unit is PUU (user unit). PT mode: it represents the pulse number the servo drive received. PR mode: the value of absolute coordinate from position command Equals to the pulse number sent by the controller.
002 (02h)	Position deviation (PUU) B	The deviation between the position command and feedback position. The unit is PUU (user unit).
003 (03h)	Feedback position (pulse) B	Current feedback position of the motor encoder. The unit is pulse (encoder unit).
004 (04h)	Position command (pulse) B	The current coordinate of the position command. The unit is pulse (encoder unit). The command that had gone through E-gear.
005 (05h)	Position deviation (pulse) B	The deviation between the position command and feedback position. The unit is pulse (encoder unit).
006 (06h)	Pulse command frequency B	Frequency of pulse command received by the servo drive. The unit is Kpps. It is suitable in PT/PR mode.
007 (07h)	Speed feedback B D1 Dec	Current speed of the motor. The unit of rotary motor is 0.1 r/min. And the unit of linear motor is 10^{-6} m/s. The value is more stable since it has been though low-pass filter.
008 (08h)	Speed command (analog) B D2 Dec	The speed command is issued by analog. The unit is 0.01 Volt.

Code	Name of Variables / Attribute	Descriptions
009 (09h)	Speed command (processed) B	The processed speed command. The unit of rotary motor is 0.1 r/min. And the unit of linear motor is 10 ⁻⁶ m/s. The source might be analog, register or position loop.
010 (0Ah)	Torque (force) command (analog) B D2 Dec	The torque (force) command is issued by analog. The unit is 0.01 Volt.
011 (0Bh)	Torque (force) command (processed) B	The processed torque (force) command. The unit is percentage (%). The source might be analog, register or speed loop.
012 (0Ch)	Average load B	The average load output by the servo drive. The unit is percentage (%).
013 (0Dh)	Peak load B	The maximum load output by the servo drive. The unit is percentage (%).
014 (0Eh)	DC Bus voltage B	Capacitor voltage after rectification. The unit is Volt.
015 (0Fh)	Inertia ratio (Total weight of linear motor and load) B D1 Dec	Rotary motor: Ratio of load inertia and motor inertia. The unit is 0.1 times. Linear motor: Total weight of linear motor and load; Unit: 0.1kg
016 (10h)	IGBT temperature B	The temperature of IGBT. The unit is °C.
017 (11h)	Resonance frequency B Dec	Resonance frequency of the system, including 2 groups of frequency, F1 and F2. When monitoring via panel, pressing SHF can switch the display of both: F2 shows no decimal point while F1 shows one. When reading through communication (mapping parameter): Low-16 Bit (Low WORD) returns frequency F2. High-16 Bit (High WORD) returns frequency F1.
018 (12h)	Z phase offset B Dec	The offset between the motor position and Z phase. The range is from -5000 to +5000. If the position is the same as Z phase, its value is 0. The bigger the value is, the more the offset will be.
019 (13h)	Mapping parameter # 1 B	Return the value of parameter P0-25 which is mapped by P0-35
020 (14h)	Mapping parameter # 2 B	Return the value of parameter P0-26 which is mapped by P0-36
021 (15h)	Mapping parameter # 3 B	Return the value of parameter P0-27 which is mapped by P0-37

Code	Name of Variables / Attribute	Descriptions
022 (16h)	Mapping parameter # 4 B	Return the value of parameter P0-28 which is mapped by P0-38
023 (17h)	Mapping monitor variable # 1 B	Return the value of parameter P0-09 which is the monitor variables mapped by P0-17
024 (18h)	Mapping monitor variable # 2 B	Return the value of parameter P0-20 which is the monitor variables mapped by P0-18
025 (19h)	Mapping monitor variable # 3 B	Return the value of parameter P0-11 which is the monitor variables mapped by P0-19
026 (1Ah)	Mapping monitor variable # 4 B	Return the value of parameter P0-12 which is the monitor variables mapped by P0-20
039 (27h)	DI status (processed) Hex	The processed DI status of the servo drive. Each bit corresponds to one DI channel. The source includes hardware channel / software P4-07 which is determined by P3-06.
040 (28h)	DO status (hardware) Hex	The real status of Digital Output hardware. Each bit corresponds to one DI channel.
041 (29h)	Drive status	Return the value of P0-46. Please refer to the description of the parameter.
043 (2Bh)	CAP, data capturing	The Data captured by CAP hardware from the latest time Note: CAP could continuously capture many points.
048 (30h)	Auxiliary encoder CNT	The value of pulse counter from auxiliary encoder (CN5)
049 (31h)	Pulse command CNT	The value of pulse counter from pulse command (CN1)
050 (32h)	Speed command (processed) D1 Dec	The processed speed command. The unit of rotary motor is 0.1 r/min. The unit of linear motor is 10^{-6} m/s. The source might be analog, register or position loop.
051 (33h)	Speed feedback (immediate) D1 Dec	Current actual speed of the motor. The unit of rotary motor is 0.1 r/min. And the unit of linear motor is 10^{-6} m/s.
052 (34h)	Speed feedback (filter) D1 Dec	Current actual speed of the motor. The unit of rotary motor is 0.1 r/min. And the unit of linear motor is 10^{-6} m/s.
053 (35h)	Torque (force) command (processed) D1 Dec	The processed torque (force) command. The unit is 0.1 percent (%). The source might be analog, register or speed loop.
054 (36h)	Torque (force) feedback D1 Dec	Current actual torque (force) of the motor. The unit is 0.1 percent (%).

Code	Name of Variables / Attribute	Descriptions
055 (37h)	Electric current feedback D2 Dec	Current actual electric current of the motor. The unit is 0.01 ampere (Amp).
056 (38h)	DC Bus voltage D1 Dec	Capacitor voltage after rectification. The unit is 0.1 volt.
059 (3Bh)	Pulse from E-Cam master axis (accumulation)	The accumulative pulse number of E-Cam master axis. It is the same as P5-86.
060 (3Ch)	Pulse from E-Cam master axis (increment)	The incremental pulse number from master axis. The unit is pulse number per msec.
061 (3Dh)	Pulse from E-Cam mast axis (lead pulse)	The lead pulse of E-Cam master axis which is used to judge the engaging condition. When it is disengaged: lead pulse = P5-87 or P5-92. When it is engaged: lead pulse = P5-89. When the value is 0, it will be disengaged.
062 (3Eh)	The position of E-Cam axis	The position of E-Cam axis. Unit: The pulse is from the master axis. When the incremental pulse from master axis is P, the axis rotates M cycle (P5-83 = M, P5-84 = P).
063 (3Fh)	Position of E-Cam slave axis	The position of E-Cam slave axis. Unit: PUU
064 (40h)	Terminal register of PR command	In PR mode, the termination of position command (Cmd_E)
065 (41h)	Output register of PR command	In PR mode, the accumulative output of position command
067 (43h)	PR target speed	The target speed of path command in PR mode. The unit is PPS (Pulse Per Second)
068 (44h)	S-curve filter (input)	The input command of S-curve filter which is used to smooth the input command. It is effective in PR mode, E-Cam and speed command.
069 (45h)	S-curve filter (output)	The output command of S-curve filter which is used to smooth the output command. It is effective in PR mode, E-Cam and speed command.
076 (4Ch)	Speed command of PR contour	In PR mode, the programmed trapezoid speed curve is determined by the target speed, acceleration, deceleration and moving distance (before S-curve filter). The unit is PPS (Pulse Per Second).

Code	Name of Variables / Attribute	Descriptions
081 (51h)	Synchronous capture axis Incremental input pulse	When synchronous capture axis is enabled, the received pulse number between two captures can be used to measure the real distance of Mark.
084 (54h)	Synchronous capture axis Deviation pulse number	The deviation between the real output pulse and the target pulse when synchronous capture axis is enabled. If it reaches the synchronization, the value will close to 0.
096 (60h)	Firmware version Dec	It includes two versions, DSP and CPLD. When monitoring via panel, pressing the SHF Key can switch the display of both: DSP shows no decimal point while CPLD shows one. When reading through communication (parameter mapping): Low-16 Bit (Low WORD) returns DSP version number. High-16 Bit (High WORD) returns CPLD version number.
098 (62h)	PLC scan time	The update time of DI/DO. The unit is 0.5 msec.
109 (6Dh)	The amount of data array	Returns the amount of data array. The unit is DWORD (32 Bits)
111 (6Fh)	Error code of the servo drive	Error code of the servo drive: only for the control loop, not including the motion controller.
112 (70h)	CANopen SYNC TS (hasn't been through the filter)	The time the servo drive receives SYNC signal (TimeStamp) The unit is usec.
113 (71h)	CANopen SYNC TS (has been through the filter)	The time the servo drive receives SYNC signal and has been through the filter The unit is usec.
114 (72h)	CANopen timing synchronization	To synchronize the device timing with the controller during the operation. The unit is usec.
123 (7Bh)	The returned value when monitoring via panel	The returned value when monitoring via panel

7.2.2 Description of Data Array

Many functions of motion control, such as CAPTURE, COMPARE and E-Cam are the data that needs to be saved in large amount of memory space, therefore, the servo drive reserves a continuous internal space to satisfy the need. The main feature of the data array is as the followings:

Feature Introduction of Data Array	
Usage	<ul style="list-style-type: none"> ● Save the captured data of CAPTURE ● Save the compared value of COMPARE ● Save the contour table of E-Cam <p>Note: The system does not partition off the data array into the individual space of CAP, CMP and E-Cam. The user could program it according to the demand. Therefore, the space might be overlapped. Please pay close attention to it when using.</p>
Size of Data Array	<ul style="list-style-type: none"> ● 32-bit integer x 800 (refer to P5-10) ● Each data has its corresponding address. Specify the address is a must when reading or writing the data. ● The 800 data is from 0 to 799.
Data Retained	<ul style="list-style-type: none"> ● Manually set up the saving (P2-08 = 30, 35) is a must and the data should be saved in EEPROM of the servo drive. ● Save the data when it is Servo Off. ● The data will be loaded into data array automatically when it is Servo On.
Accessing Window	<ul style="list-style-type: none"> ● Should be access via parameter P5-10 ~ P5-13.

The content of data array cannot be read or wrote directly, reading or writing the data must via parameter P5-10 ~ P5-13. The description of the parameters is as the followings:

Description of Related Parameter about Data Array		
Parameter	Name	Description
P5-10	Size of data array	Return the size of data array (read-only)
P5-11	Reading / writing address	Set the desired address of reading and writing
P5-12	Reading / writing window #1	<p>Read via panel: After reading the content of P5-11, the value of P5-11 will not change.</p> <p>Write via panel: After writing the content of P5-11, the value of P5-11 will increase 1 automatically.</p> <p>-----</p> <p>Read via communication: After reading the content of P5-11, the value of P5-11 will increase 1 automatically.</p> <p>Write via communication: After writing the content of P5-11, the value of P5-11 will increase 1 automatically.</p>

Description of Related Parameter about Data Array		
Parameter	Name	Description
P5-13	Reading / writing window #2	<p>Read via panel: After reading the content of P5-11, the value of P5-11 will increase 1 automatically.</p> <p>Write via panel: It cannot be written via panel.</p> <p>-----</p> <p>Read via communication: After reading the content of P5-11, the value of P5-11 will increase 1 automatically.</p> <p>Write via communication: After writing the content of P5-11, the value of P5-11 will increase 1 automatically.</p>

Set the desired reading / writing address via P5-11 first. Then, read / write P5-12 or P5-13 in order to access the content of data array. If users desire to continuously write 3 data, 100, 200, 300 into the address of data array, 11, 12 and 13, the operation step is as follows:

A. Write via panel: Use P5-12 (reading / writing window #1), since P5-13 does not support writing via panel:

1. Set address: Set P5-11 to 11 (The first written address)
2. Write into data: Set P5-12 to 100 (After writing 100 into address 11 in data array, the value of P5-11 will increase 1 automatically.)
Set P5-12 to 200 (After writing 200 into address 12 in data array, the value of P5-11 will increase 1 automatically.)
Set P5-12 to 300 (After writing 300 into address 13 in data array, the value of P5-11 will increase 1 automatically.)

The last step is to read address 11, 12 and 13 and check if the content is the value that just wrote into.

B. Read via panel: Use P5-13 (reading / writing window #2) so as to continuously read the content.

1. Set address: Set P5-11 to 11 (The first read address)
2. Read the data: When the panel displays P5-13,
Press the **SET** Key for the first time and show the content of address 11. Then, press the **MODE** Key to exit.
Press the **SET** Key for the second time and show the content of address 12. Then, press the **MODE** Key to exit.
Press the **SET** Key for the second time and show the content of address 13. Then, press the **MODE** Key to exit.

Note: Every time when reading the data via P5-13, the value of P5-11 will increase 1 automatically. Thus the user could continuously read the data.

If reading the data via P5-12, then the value of P5-11 will not change. The user is unable to read the next data automatically.

If users desire to read / write the data array via communication, the operation procedure is similar to panel. Moreover, the function of P5-12 and P5-13 is the same. If users desire to write 6 data, 100, 200, 300, 400, 500 and 600 into the address of data array via Modbus communication command 0x10 (continuous writing), the content of the issued command is as the followings:

Content of Communication Command: Write into Data Array									
No.	Command	Start Add.	Written Amount	P5-11		P5-12		P5-13	
				Low Word	High Word	Low Word	High Word	Low Word	High Word
1	0x10	P5-11	6 (Word)	11	0	100	0	200	0
				The first address		The first data		The second data	
2	0x10	P5-11	6 (Word)	13	0	300	0	400	0
				The third address		The third data		The fourth data	
3	0x10	P5-11	6 (Word)	15	0	500	0	600	0
				The fifth address		The fifth data		The sixth data	

If users desire to read the value of data array in order to check the previous written content, users can write the desired reading start address into P5-11 via MODBUS communication command 0x06 (write 1 data). The issuing communication command is as the following:

Content of Communication Command: Set the Reading Address of Data Array			
No.	Command	Start Add.	Written Data
4	0x06	P5-11	11

Then, read the content of specified address by communication command 0x03 (continuous reading). The issuing communication command is as follows:

Content of Communication Command: Read Data Array				Return Data					
No.	Command	Start Add.	Read Amount	P5-11		P5-12		P5-13	
				Low Word	High Word	Low Word	High Word	Low Word	High Word
5	0x03	P5-11	6 (Word)	11	0	100	0	200	0
				Read address		Data of address 11		Data of address 12	
6	0x03	P5-11	6 (Word)	13	0	300	0	400	0
				Read address		Data of address 13		Data of address 14	
7	0x03	P5-11	6 (Word)	15	0	500	0	600	0
				Read address		Data of address 15		Data of address 16	

The return value on the right-hand side of the above table represents the read parameter, P5-11, P5-12 and P5-13, which is also the content of address 11~16 in data array.

7.3 Description of Motion Axes

The motion axis is an internal counter of the servo drive. It is used for counting the absolute position of the axis (32-bit integer). The following motion axes are included in this servo drive:

Name of the Axis	Description	Access	Attribute
1. Main Encoder (P5-16)	It represents the absolute feedback position of the motor. The unit is PUU (user unit).	R	Physical Axis
2. Auxiliary Encoder (P5-17)	It is counted by the pulse signal from CN5 and usually connects to the second encoder or linear scale. Its pulse is A/B type.	R/W	Physical Axis
3. Pulse Command (P5-18)	It is counted by the pulse signal from CN1 and usually connects to the pulse command of the controller. The pulse type could be set by P1-00.	R/W	Physical Axis
4. Capture Axis (P5-37)	It is the axis which has CAP function. Its command source could be the above mentioned axis 1~3, which can write the new value into it and has an offset from the physical axis. Moreover, after capturing the first point, the axis position can be redefined.	R/W	Functional Axis
5. Compare Axis (P5-57)	It is the axis which has CMP function. Its command source could be the above mentioned axis 1~4, which can write the new value into it and has an offset from the physical axis.	R/W	Functional Axis
6. Master Axis (P5-86)	It is the master axis of E-Cam. Its command source could be the above mentioned axis 2, 3, 4 and 7, which can write the new value into it and has an offset from the physical axis.	R/W	Functional Axis
7. Command Axis in PR Mode	The command position is from the path generator in PR mode.	R	Virtual Axis
8. Internal Time Axis	It is the internal accumulative time counter of the servo drive. The value increases 1 every 1ms.	R	Virtual Axis
9. Synchronous Capture Axis (P5-77)	It is similar to Capture Axis (P5-37); however, it automatically adjusts the incremental pulse between two CAPs to the setting value of P5-78.	R/W	Virtual Axis

Note: Physical Axis: The position value is counted from the actual hardware signal.

Functional Axis: It is the virtual axis which has been processed by the physical. The value might not be the same as the source of physical axis. However, the incremental value is the same as the one in physical axis.

Virtual Axis: The axis position comes from the internal firmware of the servo drive. The command axis of PR mode is not instantaneous; therefore, it cannot be the command source axis of CAP and CMP function. However, it could be the command source of master axis of E-Cam.

7.4 Description of PR Mode

PR Procedure: It is the smallest unit of command. Command could be one or many procedures to constitute.

Procedure is triggered by DI.CTRG. POS0~POS5 is used to specify the triggered procedure number.

The triggered procedure is completed and will trigger the next one automatically. The procedure number can be set and the delay time between procedures as well.

The E-Cam function is provided in PR mode. It can be enabled via PR procedure. After it is disabled, it can return to the specified PR procedure.

7.5 The Difference between General PR Mode and the One in ASDA-A2R

	General PR Mode	PR Mode in A2R
Command Number	8	64
Command Type	Positioning Command	Positioning / Constant speed Command PR jump, write in parameters
Position Command Parameter	<ul style="list-style-type: none"> ● Absolute or incremental ● Acceleration/Deceleration time x 1 set ● Motion speed x 8 sets ● Delay time x 8 sets 	<ul style="list-style-type: none"> ● Absolute / incremental can be set individually ● Acceleration/Deceleration time x 16 sets ● Motion speed x 16 sets ● Delay time x 16 sets
Command Triggering Time	It has to wait until DO.ZSPD is ON	Anytime will do. It could specify the next command issuing method (in sequence / interrupt / overlap)
Command Triggering Method	<ul style="list-style-type: none"> ● Use DI.CTRG + POSn 	<ul style="list-style-type: none"> ● Use DI.CTRG + POSn ● Event trigger: DI.Event + CAP complete ● P5-07, fill in PR number to trigger.
Position Command PROFILE	<ul style="list-style-type: none"> ● Trapezoid curve with S-curve filter (If S-curve is not enabled, then it has no function of acceleration / deceleration) 	<ul style="list-style-type: none"> ● Trapezoid curve with S-curve filter (Trapezoid curve and S-curve can be set individually.)
Format of Position Command	<ul style="list-style-type: none"> ● Two register for turns and pulse within one turn respectively. 	<ul style="list-style-type: none"> ● PUU (32bit)
Homing Function	<ul style="list-style-type: none"> ● The function is enabled automatically when the power is On. (Servo ON for the first time) ● Use DI.SHOM to trigger 	<ul style="list-style-type: none"> ● The function is enabled automatically when the power is On. (Servo ON for the first time) ● Use DI.SHOM to trigger ● PR 0 = Homing ● After homing is completed, the specified PR will be executed automatically.
Software limit protection	No	Yes

7.6 The Position Unit of PR Mode

The position data of PR mode is represented by PUU (Pulse of User Unit). It is also the proportion between the controller position unit and the internal position unit of the servo drive, which is the so-called electronic gear ratio of the servo drive.

- 1) The position unit of the servo drive (pulse):

Delta' s 20bit rotary motor: Encoder unit: 1280000 (pulse/rev), which will not change.

Motor from other brands: Unit is single-phase pulse.

- 2) User unit (PUU): The unit of the controller.

Delta' s 20bit rotary motor: P pulse per revolution (PUU/rev), the gear ratio should set as:

$$\text{GEAR_NUM(P1-44)} / \text{GEAR_DEN(P1-45)} = 1280000 / P$$

Rotary motor from other brands: P pulse per revolution (PUU/rev), the gear ratio should set as:

$$\text{GEAR_NUM(P1-44)} / \text{GEAR_DEN(P1-45)} = X / P$$

X = encoder resolution (pulse/rev)

Linear motor: if $1\text{PUU} = P \mu\text{m}$, the gear ratio should set as:

$$\text{GEAR_NUM(P1-44)} / \text{GEAR_DEN(P1-45)} = P * X$$

X = encoder resolution ($\mu\text{m}/\text{pulse}$), which is the width of single-phase pulse.

7.7 Description of Register in PR Mode

- 1) Position register of PR mode: All is represented in PUU (Pulse of User Unit).
- 2) Command register (monitor variable 064): Command termination register Cmd_E. It represents the absolute terminal coordinate of position command.
- 3) Command output register (monitor variable 001): Cmd_O; it represents the absolute coordinate from the current output command.
- 4) Feedback register (monitor variable 000): Fb_PUU; it shows the absolute feedback position of the motor.
- 5) Deviation register (monitor variable 002): Err_PUU; it is the deviation between the register from command output and feedback register.
- 6) In PR mode, either in operation or stop status, it satisfies the condition of $\text{Err_PUU} = \text{Cmd_O} - \text{Fb_PUU}$.

Influence brought by position command:

Type of Command	When issuing the command =>	=> When command is executing =>	=> Command is completed
Absolute Positioning Command	Cmd_E = command data (absolute) Cmd_O does not change. DO.CMD_OK is OFF	Cmd_E does not change. Cmd_O continuously output ...	Cmd_E does not change. Cmd_O = Cmd_E DO.CMD_OK is ON
Incremental Positioning Command	Cmd_E+= command data (incremental) Cmd_O does not change. DO.CMD_OK is OFF	Cmd_E does not change. Cmd_O continuously output ...	Cmd_E does not change. Cmd_O = Cmd_E DO.CMD_OK is ON
Issue the command of DI : STP to stop the command anytime	Cmd_E does not change. Cmd_O continuously output DO.CMD_OK is unchangeable	Cmd_E does not change. Cmd_O stops according to the deceleration curve	Cmd_E does not change. Cmd_O = position after stop DO.CMD_OK is ON
Homing Command	Cmd_E does not change. Cmd_O does not change. DO.CMD_OK is OFF DO.HOME is OFF	Cmd_E continuously output Cmd_O continuously output	Cmd_E = the absolute position of Z Cmd_O = position after stop DO.CMD_OK is ON DO.HOME is ON
Speed Command	Cmd_E continuously output. Cmd_O continuously output. When the speed command is completed, it means the speed reaches the setting value and does not stop. DO.CMD_OK is OFF		
Enter PR (Servo Off->On or switch the mode and enter into PR mode)		Cmd_O = Cmd_E = current feedback position	
Note: The incremental positioning command is accumulated by command termination Cmd_E. It is neither related to the current position of the motor nor the command time.			

7.8 Homing Description of PR Mode

The purpose of homing is to connect the Z pulse position of motor encoder to the internal coordinate of the servo drive. The coordinate value corresponded by Z pulse can be specified.

After homing is completed, the stopped position will not be the Z pulse. It is because it has to decelerate to stop when finding the Z pulse. It might therefore exceed a bit. However, since the position of Z pulse has correctly setup, it would not influence the accuracy of positioning. For example, when specifying the coordinate value corresponded by Z pulse is 100 and it is $Cmd_O = 300$ after homing, it means the deceleration distance is $300 - 100 = 200$ (PUU). Since $Cmd_E = 100$ (Z's absolute coordinate), if desire to return to Z pulse position, issuing the positioning command will do, absolute 100 command or incremental 0 command.

After homing is completed, it will execute the specified PR automatically, which can move a distance of offset after homing.

When it is executing homing, software limit is disabled.

7.9 DI / DO Provided by PR Mode and Diagrams

DI signal:

CTRG, SHOM, STP, POS 0~5, ORG, PL(CCWL), NL(CWL), EV1~4

DO signal:

CMD_OK, MC_OK, TPOS, ALM, CAP_OK, CAM_AREA

System frame:

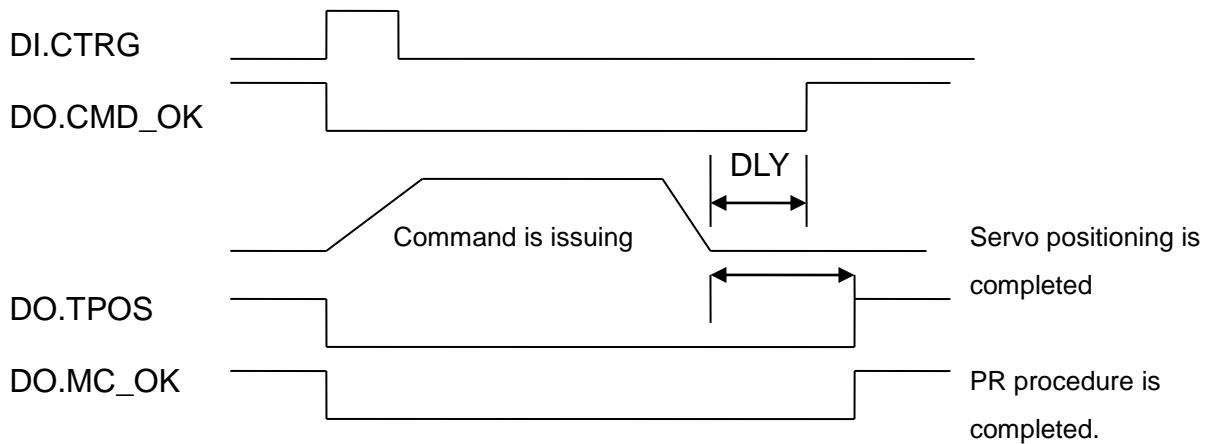

Description of command triggered method in PR mode:

64 command procedures are in each axis of PR mode. Procedure #0 is homing and the others (#1~#63) are the procedures that users can self-define. The command triggered method is concluded as the followings:

	Command Source	Description
Standard trigger	DI.CTRG + POS0 ~ 5	Use DI.POS0 ~ 5 to trigger the desired procedure number. Then, use the rising edge of DI.CTRG to trigger PR command. Application: PC or PLC that issues command via DI
Functional trigger	DI.STP, SHM	When DI.STP is from OFF → ON, the command stops in half way. When DI.SHM is from OFF → ON, it starts homing.
Event trigger	DI.EV1~4	The change status of DI.EV1 ~ 4 can be the triggered event. Set the triggered procedure number from OFF → ON by parameter P5-98. Set the triggered procedure number from ON → OFF by parameter P5-99. Application: connect to the sensor and trigger the preset procedure.
Software trigger	P5-07	Directly write the procedure number into P5-07 and trigger command. Both panel and communication (RS-485 / CANopen) can do. Application: PC or PLC that issues command via communication.
Other	CAP trigger E-CAM disengage trigger	After the capture is completed, procedure #50 can be triggered and activated by the setting value Bit3 of P5-39 X. When E-cam is disengaged and returns to PR mode, the procedure specified by P5-88 BA setting value can be triggered.

7.10 Parameter Settings in PR Mode

1) Target speed: P5-60 ~ P5-75, 16 PR in total

Rotary Motor:

	32 ~ 0 BIT
W0	TARGET_SPEED: 0.1 ~ 6000.0 (r/min)

Linear Motor:

	32 ~ 0 BIT
W0	TARGET_SPEED: 1 ~ 15999999 (10 ⁻⁶)

2) Acceleration / Deceleration time: P5-20 ~ P5-35, 16 PR in total

	15 ~ 0 BIT
W0	T_ACC / T_DEC: 1 ~ 65500 (msec)

3) Pause time: P5-40 ~ P5-55, 16 PR in total

	15 ~ 0 BIT
W0	IDLE: 0 ~ 32767 (msec)

4) PR parameter: P5-00 ~ P5-09, P6-00 ~ P6-01, 12 DWORD in total

	32 BIT
P5-00	Reserved
P5-01	Reserved (It is for testing only, do not use)
P5-02	Reserved (It is for testing only, do not use)
P5-03	Deceleration time of auto protection
P5-04	Homing mode
P5-05	1 st Speed setting of high speed homing
P5-06	2 nd Speed setting of low speed homing
P5-07	PR command register
P5-08	Forward software limit
P5-09	Reverse software limit
P6-00	Homing setting
P6-01	Origin definition

Note: Path (procedure)

5) PR definition: P6-02 ~ P7-27, (64 BIT), 63 sets of PR in total (2N)

	31 ~ 28	27 ~ 24	23 ~ 20	19 ~ 16	15 ~ 12	11 ~ 8	7 ~ 4	3 ~ 0 BIT
DW0	TYPE
DW1	DATA (32 bit)							

Each PR has two parameters, the PR function is determined by TYPE. DATA represents position or speed data while the others are the additional information.

6) SPEED, Constant speed control: TYPE = 1

	31 ~ 28	27 ~ 24	23 ~ 20	19 ~ 16	15 ~ 12	11 ~ 8	7 ~ 4	3 ~ 0 BIT
DW0	-	-	DLY	-	DEC	ACC	OPT	1
DW1	DATA (32 bit): Target Speed ; Unit is defined by OPT.UNIT							

When this command is executing, the motor accelerates or decelerates from the current speed until it reaches the target speed. After the command is completed, the motor will remain at the same speed and never stop.

OPT:

OPT selection			
7	6	5	4 BIT
-	UNIT	AUTO	INS

※DI.STP stop and software limit are acceptable.

INS: When this PR is executing, it will interrupt the previous PR.

AUTO: When the speed reaches the constant speed area, the next PR will be loaded automatically.

UNIT: 0 unit is 0.1r/min (10^{-6} m/s for linear motor); 1 unit is PPS (Pulse Per Second)

ACC/DEC: 0 ~ F, acceleration / deceleration number (4 BIT)

ACC / DEC (4)

Index P5-20 ~ P5-35

SPD: 0 ~ F, target speed number (4 BIT)

SPD (4)

Index P5-60 ~ P5-75

DLY: 0 ~ F, delay time number (4 BIT). The delay after executing this PR. The external INS is invalid.

DLY (4)

Index P5-40 ~ P5-55

7) POSITION, Positioning control: (TYPE = 2, PR is completed and stopped), (TYPE = 3, the next PR is executed automatically after the PR is completed)

	31 ~ 28	27 ~ 24	23 ~ 20	19 ~ 16	15 ~ 12	11 ~ 8	7 ~ 4	3 ~ 0 BIT
DW0	-	-	DLY	SPD	DEC	ACC	OPT	2 or 3
DW1	DATA (32 bit): target position, Unit: Pulse of User Unit							

OPT:

OPT Selection				Description
7	6	5	4 BIT	
CMD		OVLP	INS	
0	0	-	-	Absolute positioning command: Cmd_E=DATA (Note 1)
1	0			Incremental positioning command: Cmd_E= Cmd_E + DATA (Note 2)
0	1			Relative positioning command: Cmd_E= current feedback +DATA (Note 3)
1	1			CAP positioning command: Cmd_E=CAP position + DATA (Note 4)

※DI.STP stop and software limit are acceptable.

INS: When this PR is executing, it will interrupt the previous PR

OVLP: It is allowed to overlap the next PR. When overlapping, please set DLY to 0.

CMD: The calculation of the position terminal command (Cmd_E) is as the followings:

Note 1: Position terminal command is determined by DATA.

Note 2: Position terminal command is determined by the previous terminal command (Monitor variable 40h) plus DATA.

Note 3: Position terminal command is determined by the current feedback position (Monitor variable 00h) plus DATA.

Note 4: Position terminal command is determined by the position latched by CAP (Monitor variable 2Bh) plus DATA.

8) Special code: TYPE = 7, jump to the specified PR

	31 ~ 28	27 ~ 24	23 ~ 20	19 ~ 16	15 ~ 12	11 ~ 8	7 ~ 4	3 ~ 0 BIT
DW0	-	-	DLY	-	FUNC_CODE	-	OPT	7
DW1	PATH_NO (0 ~ 63)							

OPT:

OPT selection			
7	6	5	4 BIT
-	-	-	INS

PATH_NO: The jump target procedure number

FUNC_CODE: Reserved

DLY: The delay time after jump

9) Special code: TYPE = 8, write the specified parameter

	31 ~ 28	27 ~ 24	23 ~ 20	19 ~ 16	15 ~ 12	11 ~ 8	7 ~ 4	3 ~ 0 BIT
DW0	0	S_D	DLY	DESTINATION			OPT	8
DW1	SOURCE							

DLY: The delay time after write

Bit28 ~ Bit31 are not 0x0, then AL213 occurs.

S_D: Specified data source and written target.

S_D Specified Selection					
27	26	25	24 BIT	Description	
SOUR		Rsvd	DEST	Data Source	Written Target
0	0	0	0	Constant	Parameter, Px-xx
0	1		0	Parameter, Px-xx	Parameter, Px-xx
1	0		0	Data array	Parameter, Px-xx
1	1		0	Monitor variable	Parameter, Px-xx
0	0		1	Constant	Data array
0	1		1	Parameter, Px-xx	Data array
1	0		1	Data array	Data array
1	1		1	Monitor variable	Data array

Rsvd is not 0, then AL213 occurs.

OPT :

OPT Selection			
7	6	5	4 BIT
-	ROM	AUTO	INS

Para_Data: the written data

INS: When executing this PR, it interrupts the previous one.

AUTO: When this PR is completed, it will execute the next PR automatically.

ROM: 1 means to write into EEPROM at the same time. (The supported written target is parameter, if the target is data array, then it will not be written into EEPROM.)

DESTINATION: Setting of the written target

	DESTINATION		
	19 ~ 16	15 ~ 12	11 ~ 8 BIT
When DEST = 0, it represents parameter, Px-xx	P_Grp	P_Idx	
When DEST = 1, it represents data array.	Array_Addr		

P_Grp, P_Idx: Specified parameter group and number.

Array_Addr: The position of specified data array

SOURCE: Setting of data source

	SOURCE								
	31 ~ 28	27 ~ 24	23 ~ 20	19 ~ 16	15 ~ 12	11 ~ 8	7 ~ 4	3 ~ 0 BIT	
SOUR = 00 means constant	Para_Data								
SOUR = 01 means parameter Px-xx	Rsvd (0x0000 0)					P_Grp	P_Idx		
SOUR = 10 means data array	Rsvd (0x0000 0)					Array_Addr			
SOUR = 11 means monitor variable	Rsvd (0x0000 00)						Sys_Var		

P_Grp, P_Idx: specified parameter group and number

Array_Addr: specified the position of data array

Para_Data: the written constant

Sys_Var: monitor parameter code. Refer to P0-02 for its setting.

When Rsvd is not 0, it will display AL213. When P_Grp exceeds the range, it will display AL.207. When displaying AL.209, it means P_Idx exceeds the range.

When Array_Addr exceeds the range, it will display AL.213. And AL.231 is for Sys_Var exceeding the range.

Note: 1. Even when the written parameter is retained, the new value will not be written into EEPROM. Too frequent written will not shorten the lifetime of EEPROM.

Note: The aim of writing parameters via PR procedure is for turning ON/OFF or adjusting some functions. (e.g. according to different positioning command to adjust P2-00, Position Loop Gain.) This procedure will continuously repeat during the operation. If the data is all written into EEPROM, it will shorten the lifetime of EEPROM. In addition, if P2-30 is set to 5, the modified parameters (either from panel or communication) will not be saved and is inconvenient to use. Thus, this new function is added.

2. If writing parameters fails, alarm AL.213~219 will occur (Refer to Chapter 11 of the manual) and the next PR which is enabled by AUTO function will not be executed.

10) Special code: TYPE = 0xA, Indexing command

	31 ~ 28		27 ~ 24	23 ~ 20	19 ~ 16	15 ~ 12	11 ~ 8	7 ~ 4	3 ~ 0 BIT
DW0	-		OPT2	DLY	SPD	DEC	ACC	OPT	0xA
DW1	DATA (32 bit): indexing coordinates command; Unit: PUU								

OPT :

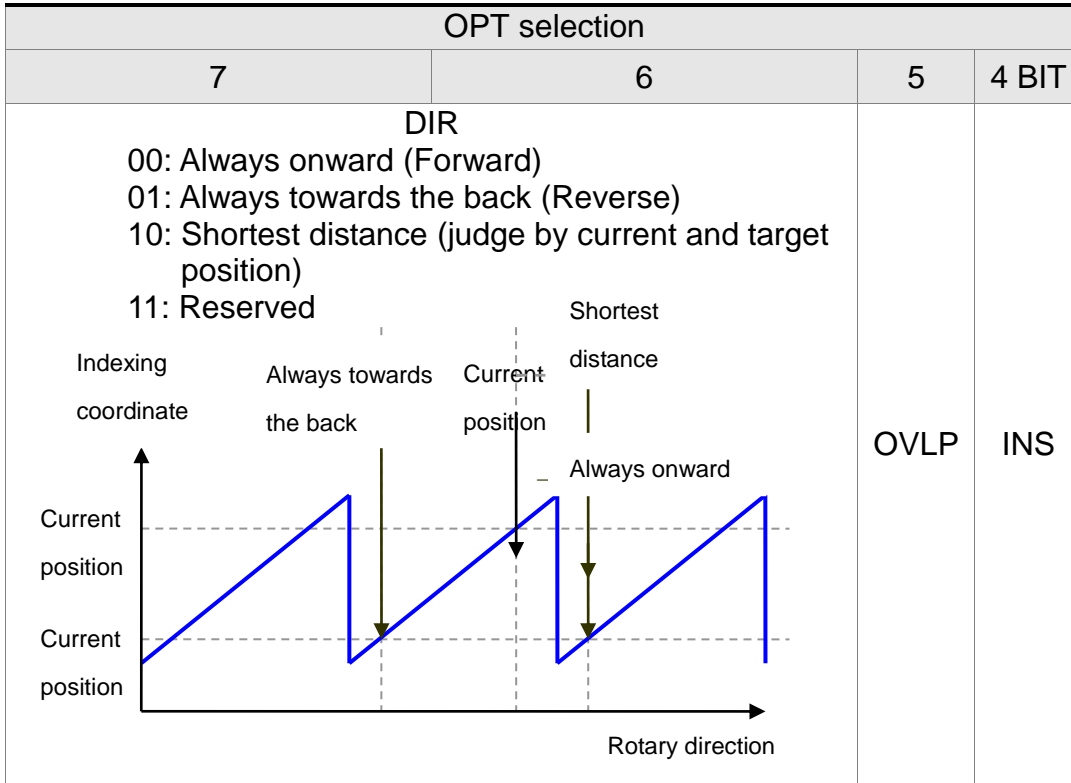

INS: When this PR is executing, it interrupts the previous one.

OVLP: It is allowed to overlap the next PR. When overlapping, please set DLY to 0.

OPT2 :

OPT2 Selection			
27	26	25	24 BIT
-	AUTO	-	S_LOW

AUTO: Position reached and the next PR is loaded automatically.

S_LOW: Selection of speed unit. 0 means the unit is 0.1r/min; while 1 means 0.01r/min

DATA (DW1) Data format:

DW1 : DATA (32 bits)
PUU : 0 ~ (P2-52 - 1)

P2-52: Size of indexing coordinate

11) Homing setting: P6-00 ~ P6-01, (64 BIT) one set of PR.

	31 ~ 28	27 ~ 24	23 ~ 20	19 ~ 16	15 ~ 12	11 ~ 8	7 ~ 4	3 ~ 0 BIT
DW0	BOOT	-	DLY	-	DEC1	ACC	PATH	BOOT
DW1	ORG_DEF (32 bit)							

PATH: 0 ~ 3F, (6 BIT)

00 (Stop): Homing completed and stops

01 ~ 3F (Auto): Homing completed and executes the specified PR: 1 ~ 63.

Note: PATH (procedure)

ACC: Acceleration time

DEC1/DEC2: The first / second deceleration time

DLY: Delay time

BOOT: Activation mode. When the POWER is ON:

0: will not do homing

1: start homing (Servo ON for the first time)

ORG_DEF: the coordinate value of the origin definition which might not be 0

A. After finding the origin (Sensor or Z), the motor has to decelerate to stop. The stop position will slightly exceed the origin. After the positioning is completed, users can determine and setup the motor position:

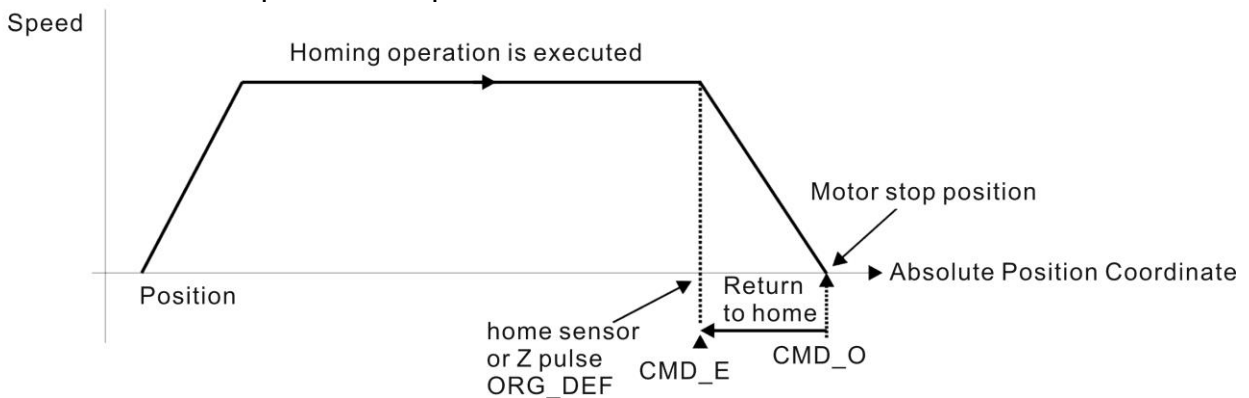

If not returning to the original point, set PATH to 0 .

If desire to return to the original point, set PATH to non-zero value and setup that

PR: absolute positioning command = ORG_DEF.

CMD_O: Command Output Position

CMD_E: Command End Position

B. Homing does not define the offset value but uses PATH to specify a path as the offset value.

After finding the origin, if the user desires to move a short distance of offset S (the related home Sensor or Z) and set the coordinate to P after moving: (incremental positioning command = S will do)

7.10.1 The Relation between the Previous Path and the Next Path

1) Interrupt (the previous path) and overlap (the next path) can be set in every path

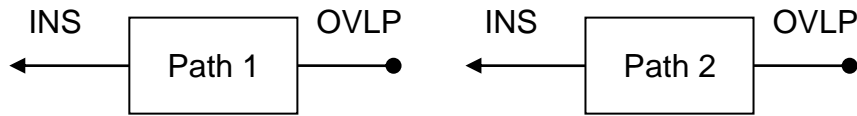

Note: Path (procedure)

2) The priority of interrupt command is higher than overlap

PATH 1	PATH 2	Relation	Output	Note
OVLP=0	INS=0	In sequence	DLY 1	PATH 1/2 which could be the combination of speed/position
OVLP=1	INS=0	Overlap	NO DLY	PATH 2 is SPEED and does not support overlap
OVLP=0	INS=1	Interrupt	N/A	PATH 1/2 which could be the combination of speed/position
OVLP=1				

7.10.2 Programming the Path in PR Mode

1) Sequence command

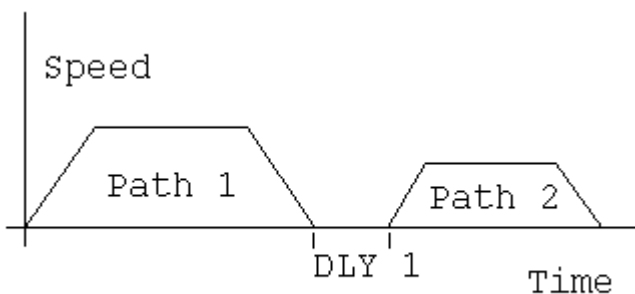

Path 1: is AUTO and has set DLY
Path 2: does not set INS

(DLY starts to count after completing the command)

Path 1: speed command and has set DLY

Path 2: position command

(DLY starts to count after completing the command)

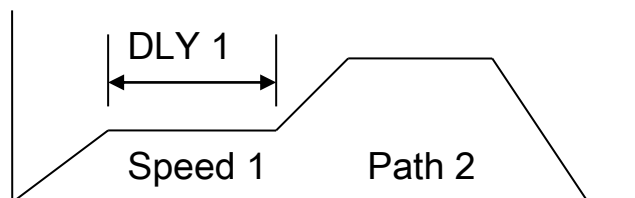

2) Overlap

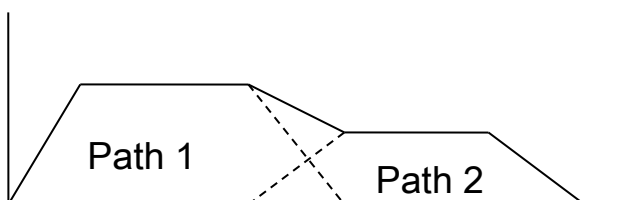

Path 1: has set OVLP but cannot set DLY

Path 2: does not set INS

3) Internal Interrupt

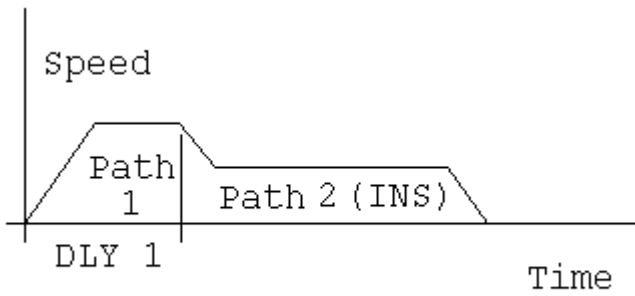

Path 1: AUTO and has set DLY
 Path 2: has set INS

(DLY is effective to the internal interrupt)

It can be used to pre-constitute complicated Profile

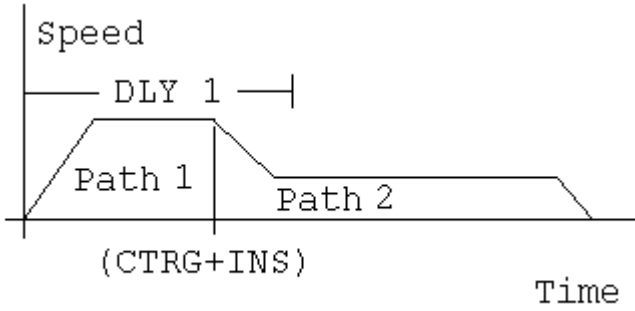

4) External interrupt

Path 1: AUTO or SINGLE

Regardless the setting of DLY

Path 2: has set INS

(DLY is ineffective to the external interrupt)

Profile can be changed from external any time

7.11 The Description of E-Cam Function

E-Cam is a virtual cam which is implemented by software. It includes Master axis and Slave axis. The illustration is as the following:

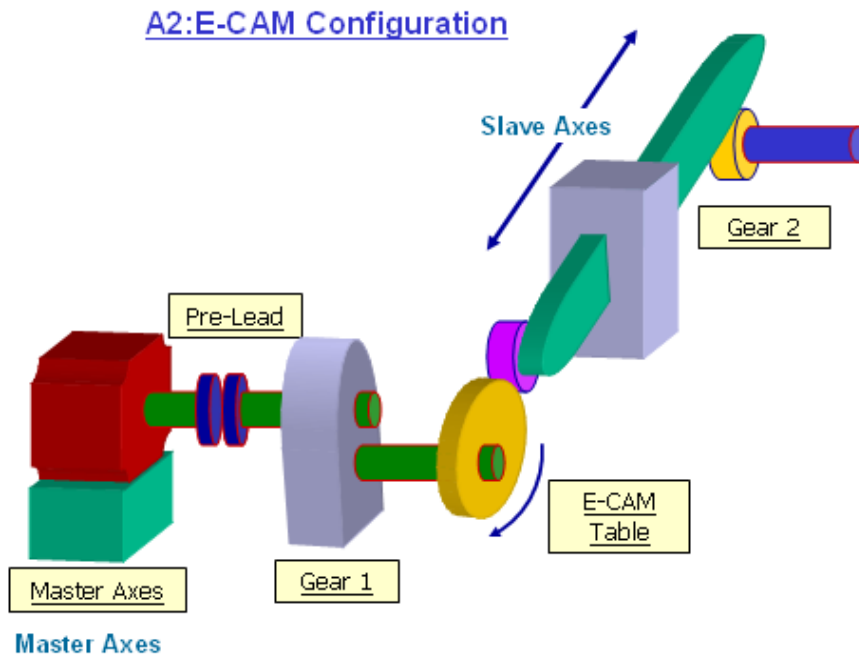

In PT mode, the position command (slave) is issued by the external pulse input (master). The two is merely the linear scaling relation (its scaling equals to e-gear ratio). However, instead of linear scaling, E-Cam is defined by cyclic curve profile, just like the cam shape. In physical machine cam, slave axis can operate as variable speed motion, alternating motion, intermittent motion, etc by master axis with the constant speed motion. It is very extensive in application. Using E-Cam could have similar effect. The following table describes the differences between E-Cam and Machine Cam.

	Machine Cam	E-Cam
Structure	Return to the original position after rotating a cycle.	It might not return to the original position after rotating a cycle. The structure could be in spiral shape like mosquito coil incense.
Smooth Performance	It is determined by the fineness of the real process.	It is interpolated by cubic curve via software
Position Accuracy	Very precise (when it has no vibration)	The command is very precise, but the actual position might have deviation due to the servo delay.
Long Distance Motion	The longer the slave axis is, the bigger the cam will be. It is not easy to make.	Change the value of the table will do. It is easy to realize.
The Necessity of Master Axis	The master axis is necessary.	The master axis is unnecessary when it is applied to constant speed motion. It will do by using the internal signal of the servo drive.
Flexibility	It is inconvenient to change and modify and it is expensive as well.	It will do by re-setting the parameter.

	Machine Cam	E-Cam
Maintenance	Machine will wear and the maintenance is necessary.	No need to maintain.
Others	The master axis needs space and it consumes energy as well.	Save the space and energy which protects the environment.

The main feature of E-Cam is as the followings:

Features of E-Cam	
Operation	Operate the E-cam in PR mode only.
Active the E-Cam Function P5-88.X	0: disable E-cam function and force to disengage (default). 1: enable E-cam function and starts to judge the engaged condition.
E-Cam Status	Stop / Pre-engage / Engage
Source of Master Axis	<ul style="list-style-type: none"> ● Auxiliary encoder (linear scale) ● Pulse command ● CAP axis (defined by CAP function) ● PR command ● Time axis ● Synchronous capture axis
Motion Command of the Servo Drive	<p>The overlap motion command issued by PR and E-Cam</p> $\text{Command of the Servo Drive} = \text{E-Cam command} + \text{PR command}$ <ul style="list-style-type: none"> ● The command will be issued only in Engaged status ● PR command is effective regardless to the E-Cam status. Except when E-cam is engaging and the source of master axis is PR command, PR command is 0. <p>When E-Cam is operating, its position still can be adjusted by PR command (incremental command in general).</p>
Data Storage Address of E-Cam table	<ul style="list-style-type: none"> ● It is stored in Data array and the start address is set by P5-81.
Data Size of E-Cam table	<ul style="list-style-type: none"> ● It is set by P5-82. 720 points is the maximum and 5 points is the minimum.
Data Format of E-Cam table	<ul style="list-style-type: none"> ● 32-bit signed value.
Data Content of E-Cam table	<ul style="list-style-type: none"> ● Save the position of slave axis (User unit, PUU)

Features of E-Cam	
The operation of E-Cam position	<ul style="list-style-type: none"> ● The master axis operates by incremental command input. ● The slave axis issues position command incrementally. ● The start and the end of E-Cam curve profile could not always be the same. It depends on the value of E-Cam table. ● The command is interpolated by cubic curve. The torque on each point will be smoothly connected because of quadratic differential operation.
DO.CAM_AREA (DO no.= 0x18)	<ul style="list-style-type: none"> ● Digital Output (DO): CAM_AREA. If this DO is ON, it means the E-Cam axis is in the setting area.

E-Cam provided by this servo drive and below is its functional diagram:

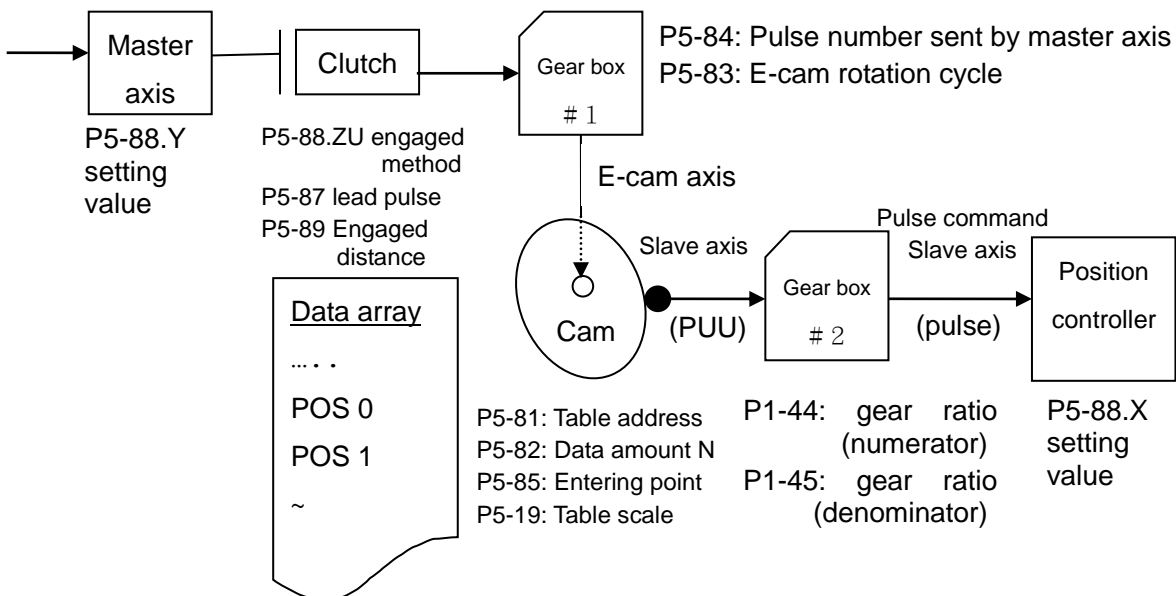

■ Master Axis, the description is as follows:

Function	The moving distance of the master axis is the source which could drive the E-Cam
Source of Master Axis The Setting Value of P5-88 Y	Source selected by P5-88.Y: <ul style="list-style-type: none"> ● Auxiliary encoder (linear scale) ● Pulse command ● PR command ● Time axis ● Synchronous capture axis ● CAP axis (defined by CAP function)
Position of Master Axis P5-86	The position of master axis can be monitored via P5-86. It also can be written before the E-cam engaged. To change this parameter will not influence the position of the slave. It is because the moving distance of master axis remains.

■ Clutch, the description is as follows:

Function	<p>It is used to determine the status of engaged / disengaged between the master axis and gear box # 1.</p> <p>The moving distance of the master axis can drive the E-Cam not until the cam is engaged.</p>
Activate E-cam function P5-88.X	<p>0: disable E-cam function (default value). If the cam is engaged, the cam will be forced to disengage.</p> <p>1: enable E-cam function and starts to judge the engaged condition</p>
E-Cam Status	<p>Status can be known via parameter P5-88.S: 0 – Stop; 1 – Engage; 2 – Pre-engage</p> <div data-bbox="579 707 1345 1077" data-label="Diagram"> <pre> graph TD Engaged["Engaged : 1"] Stop["Stop : 0"] PreEngaged["Pre-engaged : 2"] Stop -- 1 --> PreEngaged PreEngaged -- 2 --> Stop PreEngaged -- 3 --> Engaged Engaged -- 4 --> PreEngaged Engaged -- 5 --> Stop </pre> </div> <p><u>Status Description:</u></p> <ul style="list-style-type: none"> ● Stop: It is the initial status of the cam. The E-cam will not operate with the master pulse. When E-cam function is disabled (P5-88.X=0), it returns to this status. ● Pre-engage: When the engaged condition (path 1) is established, it enters this status. The E-cam still will not operate with the master pulse. ● Engage: When it reaches pre-engaged status (path 3), it enters this status. The E-cam starts to operate with the master pulse. <p><u>Path Description:</u></p> <ul style="list-style-type: none"> ● Path 1 : When the engaged condition is established (P5-88.Z), the status is Stop → Pre-engaged. The lead pulse is determined by P5-87. ● Path 2 : When the E-cam function is disabled (P5-88.X=0), it returns to Stop status. ● Path 3 : When it is in pre-engaged status, the status is Pre-engaged → Engaged. ● Path 4 : When the disengaged condition is established (P5-88.U=4), the status is Engaged → Pre-engaged.

	<p>The lead pulse is determined by P5-92. (It is available after firmware version V1.006sub04)</p> <ul style="list-style-type: none"> ● Path 5 : When the disengaged condition is established (P5-88.U=1,2,6), or the E-cam function is disabled (P5-88.X=0), the status is Engaged → Stop. 									
<p>Engage Condition P5-88.Z</p>	<p>When the E-cam is in Stop status, the method of determine engaged (path 1) is as the following:</p> <p>0: Engaged immediately. If P5-88.X is set to 1, the engaged condition is established.</p> <p>1: When DI.CAM is ON, E-cam is engaged.</p> <p>2: From CAP to engaged: E-cam is engaged when CAP function is enabled. After engaged, it starts to count the moving distance. Since the CAP position is captured by hardware, it has good instantaneity and no software delay, which is suitable for the operating master axis before engaged.</p>									
<p>Lead Pulse Monitor Variables (061)</p>	<ul style="list-style-type: none"> ● In pre-engaged status, the lead pulse is the moving distance of master axis before the E-cam is engaged (path 3). Its value decreases when input the master pulse. When the value is 0, it enters Engaged status. ● Enter Pre-engaged status via path 1, the lead pulse is determined by the value of P5-87. ● Enter Pre-engaged status via path 4, the lead pulse is determined by the value of P5-92. ● If the setting is 0, it means no lead pulse and will enter Engaged status immediately. <p>Symbol + / - represents the direction of lead pulse. Please note that the E-cam will be unable to engage if setting the wrong direction.</p> <p>If setting the wrong direction, the value of monitor variable (061) will increase, which is far from 0 and causes overflow at the end. If it overflows, the E-cam function will be disabled (P5-88.X=0) and the E-cam will be forced to return to Stop status.</p>									
<p>Disengage Condition P5-88.U</p>	<p>When the E-cam is in Engaged status, the method of determine disengaged is as the following:</p> <p>Note: 2, 4 and 6 cannot be selected at the same time</p> <table border="1" data-bbox="475 1845 1394 2047"> <thead> <tr> <th>U</th> <th>Disengage Condition</th> <th>After Disengaged</th> </tr> </thead> <tbody> <tr> <td>0</td> <td>Never disengaged. It will be forced to disengage until P5-88.X is set to 0.</td> <td>(Path 5) Enter Stop Status</td> </tr> <tr> <td>1</td> <td>DI.CAM is OFF</td> <td>(Path 5) Enter Stop Status</td> </tr> </tbody> </table>	U	Disengage Condition	After Disengaged	0	Never disengaged. It will be forced to disengage until P5-88.X is set to 0.	(Path 5) Enter Stop Status	1	DI.CAM is OFF	(Path 5) Enter Stop Status
U	Disengage Condition	After Disengaged								
0	Never disengaged. It will be forced to disengage until P5-88.X is set to 0.	(Path 5) Enter Stop Status								
1	DI.CAM is OFF	(Path 5) Enter Stop Status								

	2	Master axis receives the pulse number which is set by P5-89 and stops immediately. (The symbol represents the direction)	(Path 5) Enter Stop Status
	6	Same as 2, the E-cam starts to decelerate when disengaging. It is suitable for the application of calling the next PR position command right after disengaged.	
	4	Master axis receives the pulse number which is set by P5-89 and stops immediately. (The symbol represents the direction)	(Path 4) Returns to Pre-engage Status The lead pulse is P5-92
	8	Disable the E-cam after disengaging	Set P5-88.X = 0
Auxiliary Selection P5-88.BA	When the E-cam disengaged, if it is in the setting distance (P5-88.U=2), it returns to Stop status and can determine the execution PR number.		

■ Gear # 1, the description is as follows:

Function	<ul style="list-style-type: none"> ● Set the relativity of master axis and E-cam axis. e.g. The master axis operates one cycle, the E-cam axis is no need to operates one cycle.
Description	<ul style="list-style-type: none"> ● E-cam axis is a virtual axis. ● The E-cam axis operates one cycle (360 degrees) means the cam operates one cycle and the slave axis operates one cycle. ● The pulse number is the unit of moving distance of the master axis. Its resolution is determined by the source.
Setting Method P5-83: M P5-84: P	<ul style="list-style-type: none"> ● If the pulse number of master axis is P, the E-cam axis operates M cycle. Then, the setting of gear ratio is P5-83 = M, P5-84 = P

■ Cam, the description is as follows:

Function	<ul style="list-style-type: none"> ● Set the relation between E-cam axis and slave axis and define it in the E-cam table. E-cam axis operates one cycle and the slave axis operates one cycle.
Data Storage Address of E-Cam table	<ul style="list-style-type: none"> ● Data array, the start address is set by P5-81
Data Format	<ul style="list-style-type: none"> ● 32-bit (It has positive and negative, user unit: PUU)
E-Cam Curve Scaling P5-19 0 ~ +/- 32.700	<ul style="list-style-type: none"> ● It is used to magnify (minify) the E-cam shape. ● It equals to the value of data multiplies P5-19. ● Switch the symbol, + / - will change the operation direction

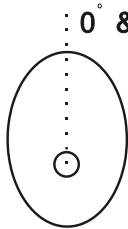
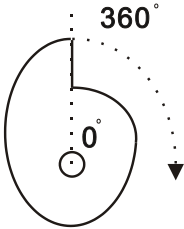
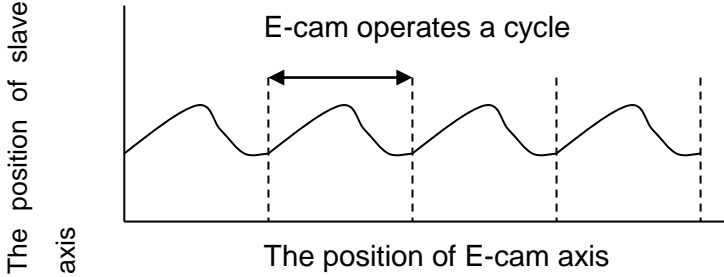
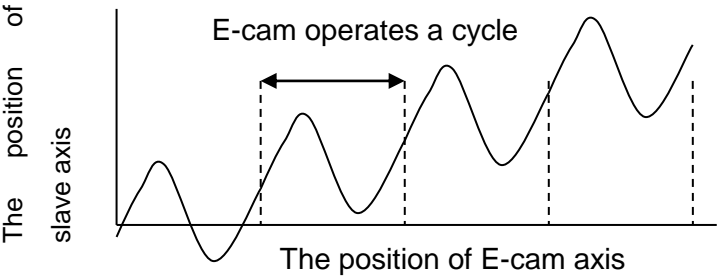
	<p>of slave axis.</p> <ul style="list-style-type: none"> ● If P5-19 is set to 0, the E-cam command will not be outputted. (The setting will be 0 for good).
<p>Data Size</p>	<ul style="list-style-type: none"> ● It is divided into N parts via P5-82 (≥ 5) and does not exceed the limit of data array. It means 360 degrees a cycle of E-cam are divided into N areas. Each area is $(360/N)$ degrees.
<p>Data Content</p>	<ul style="list-style-type: none"> ● The position data of slave axis is saved in E-cam table. (User unit: PUU). ● If E-cam is divided into N areas, the position of each area must be included in the table. It must set N + 1 points in total. It is because the position of the first point (0 degree) and the final point (360 degree) might not be the same. <div style="display: flex; justify-content: space-around; align-items: flex-start;"> <div style="text-align: center;"> <p>The data of 1.0° and 360° is the same.</p>  </div> <div style="text-align: center;"> <p>The data of 2.0° and 360° is different.</p>  </div> </div> <ul style="list-style-type: none"> ● If: <ol style="list-style-type: none"> 1. The start and final position is the same, it means after the E-cam operating a cycle, the slave axis returns to the origin position. <div style="text-align: center;">  </div> 2. The start and final position is different, it means after the E-cam operating a cycle, the slave axis does not return to the origin position. <div style="text-align: center;">  </div>
<p>Operation</p>	<ul style="list-style-type: none"> ● The slave axis is a virtual axis and the unit of slave position is

Description	<p>PUU.</p> <ul style="list-style-type: none"> ● After the E-cam is engaged, the position of the master is the entering point of P5-85. The position of the slave axis is in the corresponding point to the P5-85 in E-cam table. ● After engaging, if the master does not operate, the slave axis will not operate. If the master operates, the slave will travel according to the E-cam table. ● For one cycle of the chart, the slave axis operates a cycle. ● E-cam axis can operate in forward / reverse direction. ● If the E-cam position is between two points of the E-cam table, the position of the slave axis will be interpolated with cubic curve function. The adjacent curve remains quadratic differential at the point in order to smooth torque. The point amount of the table will not influence the smoothing operation of E-cam.
-------------	---

■ Gear # 2, the description is as follows:

Function	<ul style="list-style-type: none"> ● Set the relation between slave axis and pulse command ● The slave axis operates a cycle, but the pulse command might not operate a cycle.
Description	<ul style="list-style-type: none"> ● The slave axis is a virtual axis and the unit of slave position is PUU. ● The pulse command is the encoder unit (pulse). The resolution is 1280000 pulse/rev. ● For one cycle of the chart, the slave axis operates a cycle.
Setting Method P1-44: numerator P1-45: denominator	<ul style="list-style-type: none"> ● If the pulse number of slave axis is L, the motor axis operates R cycle. Then, the setting of gear ratio is $P1-44/P1-45 = 1280000 \times R / L$ ● The gear ratio of PT and PR is the same.

■ Digital Output of E-cam, the description is as follows:

DO Name and Number	<ul style="list-style-type: none"> ● DO.CAM_AREA (DO no.= 0x18)
Function	<ul style="list-style-type: none"> ● If DO.CAM_AREA is ON, it means the position of E-cam axis is in the setting range.
When the E-cam is engaging	<ul style="list-style-type: none"> ● Set the angle range of DO ON by P5-90 and P5-91. ● Please refer to table 1 and 2 below
When the E-cam is disengaging	<ul style="list-style-type: none"> ● DO.CAM_AREA is OFF.

Table 1 P5-90 ≤ P5-91:

E-Cam angle	0°	~	P5-90	~	P5-91	~	360°
DO:CAM_AREA	OFF	OFF	ON	ON	ON	OFF	OFF

Table 2 P5-90 > P5-91:

E-Cam angle	0°	~	P5-91	~	P5-90	~	360°
DO:CAM_AREA	ON	ON	OFF	OFF	OFF	ON	ON

7.11.1 Function Description of CAPTURE (Data Capture)

The concept of CAPTURE is to capture the position of motion axis instantaneously by using the external trigger signal DI7. Then save it in data array so as to be used for motion control afterwards. Since CAPTURE is finished by hardware, there is no problem of software delay. It also can accurately capture the high-speed motion axis. The CAPTURE features provided by this servo drive is as follows.

CAPTURE Features	
Pulse Source	<ul style="list-style-type: none"> ● Main encoder of the motor ● Auxiliary encoder (linear scale) ● Pulse command <p>The selected axis will be displayed in P5-37, the default value can be written in before capture.</p> <p>Note: When the source of COMPARE is CAP axis, the CAP source cannot be changed.</p>
Trigger signal	<ul style="list-style-type: none"> ● Triggered by DI7, the response time is 5 usec. <p>Note: DI7 directly connects to CAPTURE hardware. Thus, regardless the setting value of P2-16 (DI Code), CAPTURE can work. When using CAPTURE, in order to avoid DI error, system will force to disable DI function, which means the setting will be P2-16 = 0x0100 automatically. Since the value is not written into EEPROM, P2-16 will return to the default value after re-power on.</p>
Trigger method	<ul style="list-style-type: none"> ● Edge trigger can select contact A/B ● It is capable to continuously capture more than one point. ● It can set the trigger interval. (The interval between this trigger and the next one.)
Data storage position	<ul style="list-style-type: none"> ● Data array. The start address is set by P5-36.
Capture number	<ul style="list-style-type: none"> ● It is set via P5-38 and will not exceed the limit of data array.
Capture format	<ul style="list-style-type: none"> ● 32-bit (It has positive and negative.)
Auxiliary selection	<ul style="list-style-type: none"> ● After capturing the first data, the CAP axis coordinate system will be set to the value the same as P5-76. ● After capturing the first data, the COMPARE function is enabled automatically. ● After capturing all points, PR procedure # 50 is triggered automatically.
DO.CAP_OK	<ul style="list-style-type: none"> ● The default value is OFF. ● After capturing the last point, this DO is ON. ● Set P5-39.X0 to 1 so as to activate CAPTURE function and this DO is OFF.
Note	<ul style="list-style-type: none"> ● If P5-38=0, set the value of P5-39 X, Bit0 to 1 will disable the CAPTURE function. Clear the setting value of P5-39 X, Bit0 to 0 and set DO.CAP_OK to OFF. ● Since the capture axis is 32-bit wide, the accumulation will cause overflow. Please avoid this.

The CAP data is saved in data array and the first CAP data locates in P5-36. The CAP number has no limit, thus it can be set via P5-38. The last CAP data is saved in P5-36 + P5-38 - 1. Set the value of P5-39 X, Bit0 to 1 so as to activate CAP function. Every time when DI7 is triggered, one data will be captured and saved in data array. Then, the value of P5-38 will decrease one automatically until the CAP number reaches the setting value (P5-38 = 0). The CAP procedure is completed, the setting value of P5-39 X, Bit0 will be cleared to 0 and DO.CAP_OK is ON.

When capturing the first data, the position of CAP axis can be reset. The first CAP value will be the value set by P5-76. And the value of the second CAP data will be the incremental value from the first data. This method is called Relative Capture. If not selecting the first data reset, it is called Absolute Capture.

When capturing the first data, it automatically activates COMPARE function, which means the COMPARE function is activated via DI5.

The diagram of CAP:

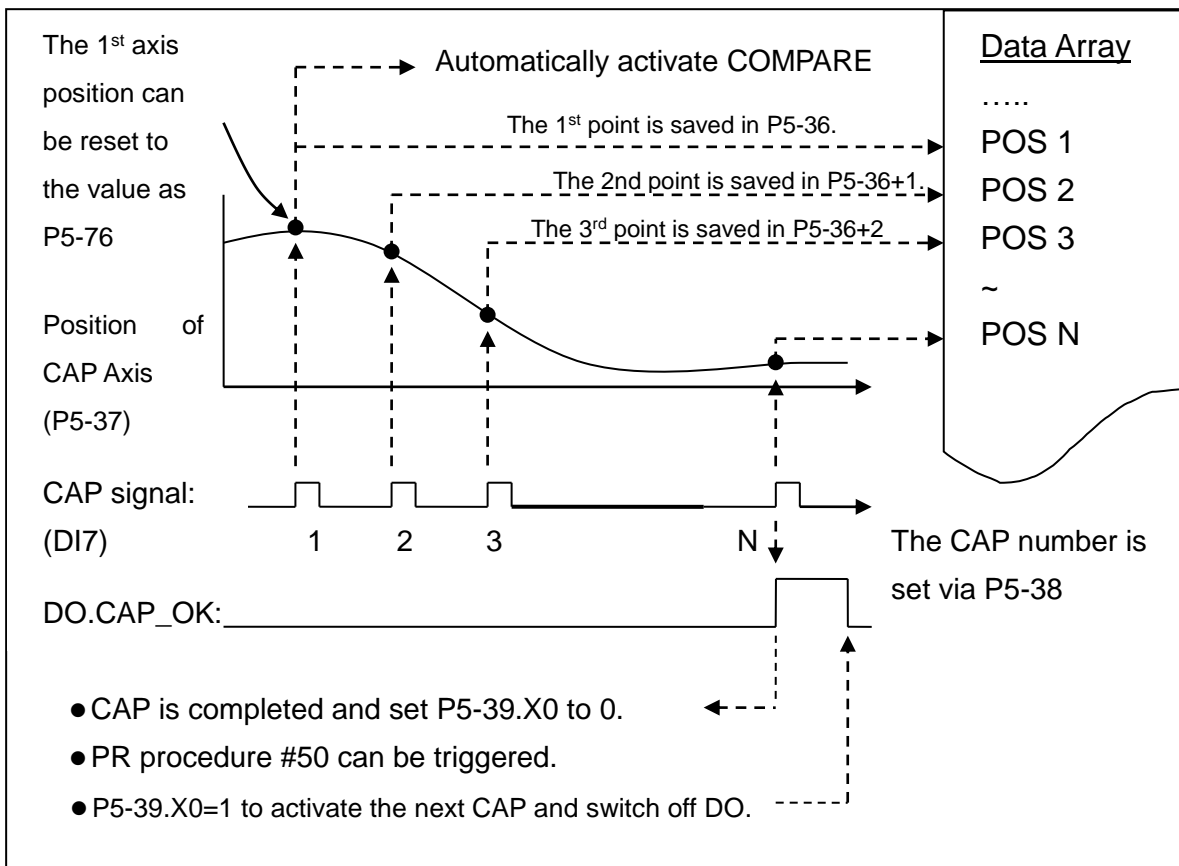

7.11.2 Function Description of COMPARE (Data Compare)

The concept of COMPARE is to compare the instant position of motion axis with the value which is saved in data array. Then output DO3 after the COMPARE condition is established for motion control. Since COMPARE is finished by hardware, there is no problem of software delay. It also can accurately compare the high-speed motion axis. The COMPARE features provided by this servo drive is as follows.

COMPARE Features	
Pulse Source	<ul style="list-style-type: none"> ● Main Encoder of the Motor ● Auxiliary Encoder (linear scale) ● Pulse Command ● CAP Axis (set by CAPTURE). When selecting this axis, CAP source cannot be changed. <p>The selected axis is displayed in P5-57. Before compare, the default value can be written in.</p>
Output Signal	<ul style="list-style-type: none"> ● Output by DO4 and the response time is 5 usec. <p>Note: DO3 directly connects to COMPARE hardware, thus, regardless the setting value of P2-20 (DO Code), the function can work. When using COMPARE, in order to avoid DO error, the system will force to disable DO function, which means the setting will be P2-21 = 0x0100 automatically. Since the value is not written into EEPROM, P2-21 will return to the default value after re-power on.</p>
Output Method	<ul style="list-style-type: none"> ● Pulse output can select contact A/B. ● It is capable to continuously output more than one point. ● It can set the pulse output time.
Data Storage Position	<ul style="list-style-type: none"> ● Data array. The start address is set by P5-56.
Compare Number	<ul style="list-style-type: none"> ● It is set via P5-58 and will not exceed the limit of data array.
Compare Format	<ul style="list-style-type: none"> ● 32-bit (It has positive and negative.)
Compare Condition	<ul style="list-style-type: none"> ● It will be triggered when the source of compare axis pass through the compare value.
Auxiliary Selection	<ul style="list-style-type: none"> ● Cycle mode: When comparing to the last point, it automatically returns to the first point and starts to compare. ● When the last compare is completed, the CAPTURE function is activated automatically.
Note	<ul style="list-style-type: none"> ● If P5-58 is set to 0, set the value of P5-59 X, Bit0 to1 will be unable to compare. Set the value of P5-59 X, Bit0 to 0. ● Since the capture axis is 32-bit wide, the accumulation will cause overflow. Please avoid this.

The value of COMPARE is saved in data array and the first compare data locates in P5-56. The CMP number has no limit, thus it can be set via P5-58. The last CMP data is saved in $P5-56 + P5-58 - 1$. Set the value of P5-59 X, Bit0 to 1 so as to activate CMP function and start to compare the first data of data array. Every time when a position saved in data array is compared, the compare DO will be outputted. Then, the value of P5-58 will decrease one automatically and compare the next value until the CMP number reaches the setting value ($P5-58 = 0$). When the CMP procedure is completed, the setting value of P5-59 X, Bit0 will be cleared to 0.

When comparing to the last point, it can select if it returns to the first data for comparing. This is called cycle mode. Or it can activate CAPTURE function and wait DI7 for triggering CAP/CMP procedure.

The diagram of COMPARE:

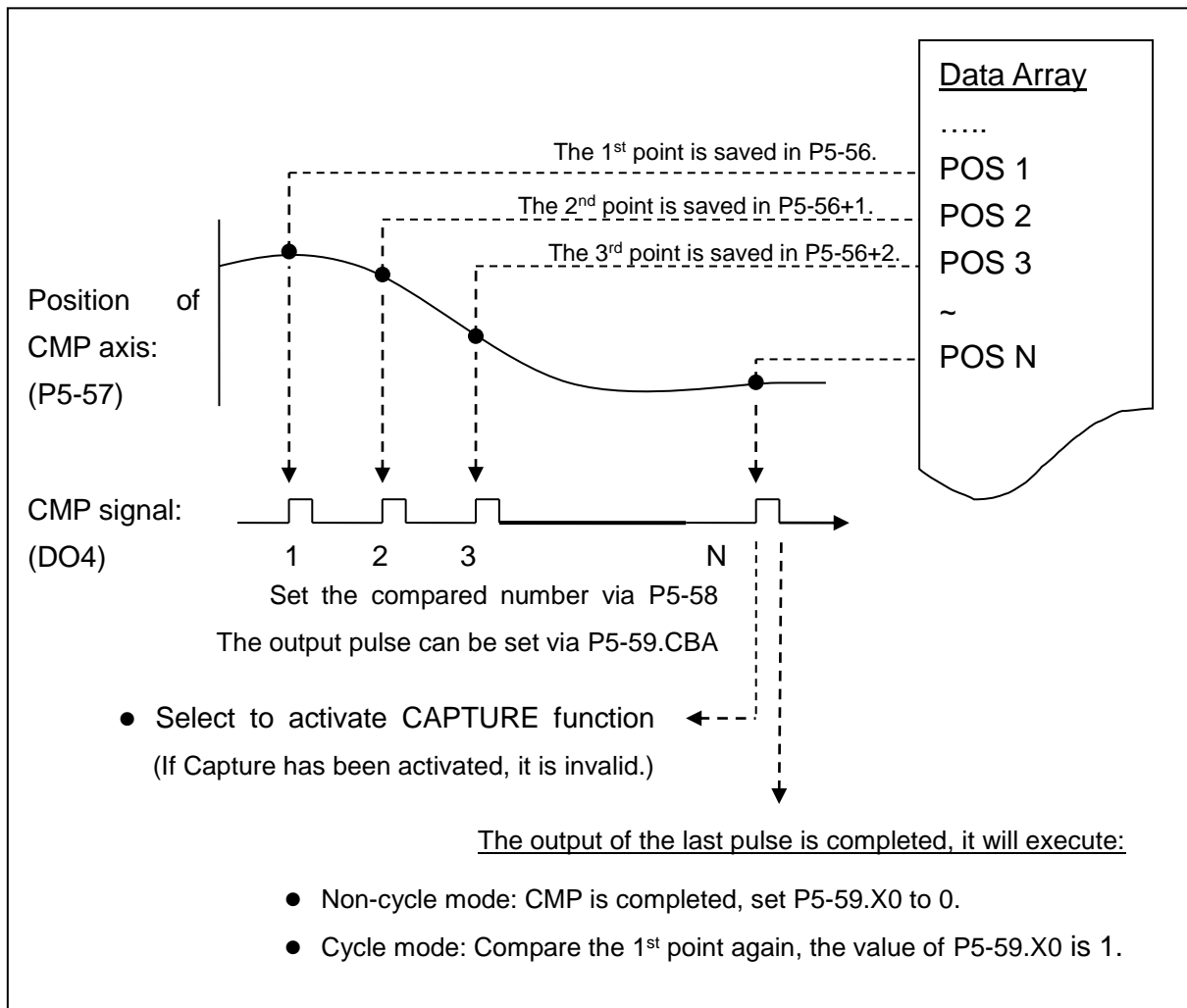

(This page is intentionally left blank.)

Chapter 8 Parameters

8.1 Parameter Definition

Parameters are divided into nine groups which are shown as follows. The first character after the start code P is the group character and the second character is the parameter character.

As for the communication address, it is the combination of group number along with two digit number in hexadecimal. The definition of parameter groups is as the followings:

Group 0: Monitor Parameters	(e.g.: P0-xx)
Group 1: Basic Parameters	(e.g.: P1-xx)
Group 2: Extension Parameters	(e.g.: P2-xx)
Group 3: Communication Parameters	(e.g.: P3-xx)
Group 4: Diagnosis Parameters	(e.g.: P4-xx)
Group 5: Motion Setting Parameters	(e.g.: P5-xx)
Group 6: PR Parameters	(e.g.: P6-xx)
Group 7: PR Parameters	(e.g.: P7-xx)
Group M: Motor Parameters	(e.g.: PM-xx)

Control Mode Description:

PT is position control mode. (Input the position command via the terminal block)

PR is position control mode. (The internal register issues the position command)

S is speed control mode.

T is torque (force) control mode.

Special Symbol Description:

- (★) Read-only register, can only read the status. For example: parameter P0-00, P0-10 and P4-00, etc.
- (▲) Setting is unable when Servo On, e.g. parameter P1-00, P1-46 and P2-33, etc.
- (●) Not effective until re-power on or off the servo drive, e.g. parameter P1-01 and P3-00.
- (■) Parameters of no data retained setting, e.g. parameter P2-31 and P3-06.

8.2 List of Parameters

Monitor and General Output Parameter									
Parameter	Abbr.	Function	Default	Unit	Control Mode				Related Section
					PT	PR	S	T	
P0-00★	VER	Firmware Version	Factory Setting	N/A	O	O	O	O	-
P0-01■	ALE	Alarm Code Display of Drive (Seven-segment Display)	N/A	N/A	O	O	O	O	11.1 11.2 11.3
P0-02	STS	Drive Status	00	N/A	O	O	O	O	7.2
P0-03	MON	Analog Output Monitor	01	N/A	O	O	O	O	4.3.5
P0-08★	TSON	Servo On Time	0	Hour					-
P0-09★	CM1	Status Monitor Register 1	N/A	N/A	O	O	O	O	4.3.5
P0-10★	CM2	Status Monitor Register 2	N/A	N/A	O	O	O	O	4.3.5
P0-11★	CM3	Status Monitor Register 3	N/A	N/A	O	O	O	O	4.3.5
P0-12★	CM4	Status Monitor Register 4	N/A	N/A	O	O	O	O	4.3.5
P0-13★	CM5	Status Monitor Register 5	N/A	N/A	O	O	O	O	4.3.5
P0-17	CM1A	Status Monitor Register Selection 1	0	N/A					-
P0-18	CM2A	Status Monitor Register Selection 2	0	N/A					-
P0-19	CM3A	Status Monitor Register Selection 3	0	N/A					-
P0-20	CM4A	Status Monitor Register Selection 4	0	N/A					-
P0-21	CM5A	Status Monitor Register Selection 5	0	N/A					-
P0-25	MAP1	Mapping Parameter # 1	No need to initialize	N/A	O	O	O	O	4.3.5
P0-26	MAP2	Mapping Parameter # 2	No need to initialize	N/A	O	O	O	O	4.3.5
P0-27	MAP3	Mapping Parameter # 3	No need to initialize	N/A	O	O	O	O	4.3.5
P0-28	MAP4	Mapping Parameter # 4	No need to initialize	N/A	O	O	O	O	4.3.5
P0-29	MAP5	Mapping Parameter # 5	No need to initialize	N/A	O	O	O	O	4.3.5

Monitor and General Output Parameter									
Parameter	Abbr.	Function	Default	Unit	Control Mode				Related Section
					PT	PR	S	T	
P0-30	MAP6	Mapping Parameter # 6	No need to initialize	N/A	O	O	O	O	4.3.5
P0-31	MAP7	Mapping Parameter # 7	No need to initialize	N/A	O	O	O	O	4.3.5
P0-32	MAP8	Mapping Parameter # 8	No need to initialize	N/A	O	O	O	O	4.3.5
P0-35	MAP1A	Target Setting of Mapping Parameter P0-25	0x0	N/A	O	O	O	O	4.3.5
P0-36	MAP2A	Target Setting of Mapping Parameter P0-26	0x0	N/A	O	O	O	O	4.3.5
P0-37	MAP3A	Target Setting of Mapping Parameter P0-27	0x0	N/A	O	O	O	O	4.3.5
P0-38	MAP4A	Target Setting of Mapping Parameter P0-28	0x0	N/A	O	O	O	O	4.3.5
P0-39	MAP5A	Target Setting of Mapping Parameter P0-29	0x0	N/A	O	O	O	O	4.3.5
P0-40	MAP6A	Target Setting of Mapping Parameter P0-30	0x0	N/A	O	O	O	O	4.3.5
P0-41	MAP7A	Target Setting of Mapping Parameter P0-31	0x0	N/A	O	O	O	O	4.3.5
P0-42	MAP8A	Target Setting of Mapping Parameter P0-32	0x0	N/A	O	O	O	O	4.3.5
P0-46★	SVSTS	Servo Digital Output Status Display	0	N/A	O	O	O	O	-
P1-04	MON1	MON1 Analog Monitor Output Proportion	100	%(full scale)	O	O	O	O	6.4.4
P1-05	MON2	MON2 Analog Monitor Output Proportion	100	%(full scale)	O	O	O	O	6.4.4

Filter and Resonance Suppression Parameter									
Parameter	Abbr.	Function	Default	Unit	Control Mode				Related Section
					PT	PR	S	T	
P1-06	SFLT	Analog Speed Command (Low-pass Filter)	0	ms			O		6.3.3
P1-07	TFLT	Analog Torque (force) Command (Low-pass Filter)	0	ms				O	6.4.3
P1-08	PFLT	Smooth Constant of Position Command (Low-pass Filter)	0	10 ms	O	O			6.2.6
P1-25	VSF1	Low-frequency Vibration Suppression (1)	100.0	0.1Hz	O	O			6.2.9
P1-26	VSG1	Low-frequency Vibration Suppression Gain (1)	0	N/A	O	O			6.2.9
P1-27	VSF2	Low-frequency Vibration Suppression (2)	100.0	0.1Hz	O	O			6.2.9
P1-28	VSG2	Low-frequency Vibration Suppression Gain (2)	0	N/A	O	O			6.2.9
P1-29	AVSM	Auto Low-frequency Vibration Suppression Setting	0	N/A	O	O			6.2.9
P1-30	VCL	Low-frequency Vibration Detection	500	pulse	O	O			6.2.9
P1-34	TACC	Acceleration Constant of S-Curve	200	ms		O	O		6.3.3
P1-35	TDEC	Deceleration Constant of S-Curve	200	ms		O	O		6.3.3
P1-36	TSL	Acceleration / Deceleration Constant of S-Curve	0	ms		O	O		6.3.3
P1-59	MFLT	Analog Speed Command	0	0.1ms			O		-
P1-62	FRCL	Friction Compensation	0	%	O	O	O	O	-
P1-63	FRCT	Friction Compensation	0	ms	O	O	O	O	-
P1-68	PFLT2	Position Command Moving Filter	0	ms	O	O			-
P1-75	FELP	Low-pass Filter Time Constant of Full-closed Loop control	100	ms	O	O			-
P2-23	NCF1	Resonance suppression (Notch filter) (1)	1000	Hz	O	O	O	O	6.3.7
P2-24	DPH1	Resonance Suppression (Notch filter) Attenuation Rate (1)	0	dB	O	O	O	O	6.3.7
P2-43	NCF2	Resonance suppression (Notch filter) (2)	1000	Hz	O	O	O	O	6.3.7
P2-44	DPH2	Resonance Suppression (Notch filter) Attenuation Rate (2)	0	dB	O	O	O	O	6.3.7

Filter and Resonance Suppression Parameter									
Parameter	Abbr.	Function	Default	Unit	Control Mode				Related Section
					PT	PR	S	T	
P2-45	NCF3	Resonance suppression (Notch filter) (3)	1000	Hz	O	O	O	O	6.3.7
P2-46	DPH3	Resonance Suppression (Notch filter) Attenuation Rate (3)	0	dB	O	O	O	O	6.3.7
P2-47	ANCF	Auto Resonance Suppression Mode Setting	1	N/A	O	O	O	O	-
P2-48	ANCL	Resonance Suppression Detection Level	100	N/A	O	O	O	O	-
P2-25	NLP	Low-pass Filter of Resonance Suppression	2 or 5	0.1m s	O	O	O	O	6.3.7
P2-33▲	INF	Semi-auto Inertia Adjustment	0	N/A	O	O	O	O	6.3.6
P2-49	SJIT	Speed Detection Filter	0	-	O	O	O	O	-

Gain and Switch Parameter									
Parameter	Abbr.	Function	Default	Unit	Control Mode				Related Section
					PT	PR	S	T	
P2-00	KPP	Position Loop Gain	35	rad/s	O	O			6.2.8
P2-01	PPR	Switching Rate of Position Loop Gain	100	%	O	O			6.2.8
P2-02	PFG	Position Feed Forward Gain	50	%	O	O			6.2.8
P2-03	PFF	Smooth Constant of Position Feed Forward Gain	5	ms	O	O			-
P2-04	KVP	Speed Loop Gain	500	rad/s	O	O	O	O	6.3.6
P2-05	SPR	Switching Rate of Speed Loop Gain	100	%	O	O	O	O	-
P2-06	KVI	Speed Integral Compensation	100	rad/s	O	O	O	O	6.3.6
P2-07	KVF	Speed Feed Forward Gain	0	%	O	O	O	O	6.3.6
P2-26	DST	Anti-interference Gain	0	0.001	O	O	O	O	-
P2-27	GCC	Gain Switching and Switching Selection	0	N/A	O	O	O	O	-
P2-28	GUT	Gain Switching Time Constant	10	10 ms	O	O	O	O	-
P2-29	GPE	Gain Switching	1280000	pulse Kpps r/min (rotary motor) 10 ⁻³ m/s (linear motor)	O	O	O	O	-
P2-31■	AUT1	Speed Loop Frequency Response Setting in Auto and Semi-auto Mode	80	Hz	O	O	O	O	5.6 6.3.6
P2-32▲	AUT2	Tuning Mode Selection	0	N/A	O	O	O	O	5.6 6.3.6

Position Control Parameter									
Parameter	Abbr.	Function	Default	Unit	Control Mode				Related Section
					PT	PR	S	T	
P1-01●	CTL	Input Setting of Control Mode and Control Command	0	pulse r/min N-M	O	O	O	O	6.1
P1-02▲	PSTL	Speed and Torque (force) Limit Setting	0	N/A	O	O	O	O	6.6

Position Control Parameter									
Parameter	Abbr.	Function	Default	Unit	Control Mode				Related Section
					PT	PR	S	T	
P1-12 ~ P1-14	TQ1 ~ 3	Internal Torque (force) Limit 1 ~ 3	100	%	O	O	O	O	6.4.1
P1-46▲	GR3	Pulse Number of Encoder Output	2500	pulse	O	O	O	O	-
P1-55	MSPD	Maximum Speed Setting	rated	r/min (rotary motor) 10 ⁻³ m/s (linear motor)	O	O	O	O	-
P1-72	FRES	Resolution of Linear Scale for full-closed loop control	5000	Pulse /rev	O	O			-
P1-73	FERR	Error Protection Range for Full-closed Loop Control	30000	pulse	O	O			-
P1-74	FCON	Full-closed Loop Control of Linear Scale	000h	-	O	O			-
P2-50	DCLR	Pulse Clear Mode	0	N/A	O	O			-
External Pulse Command (PT mode)									
P1-00▲	PTT	External Pulse Input Type	0x2	N/A	O				6.2.1
P1-44▲	GR1	Gear Ratio (Numerator) (N1)	1	pulse	O	O			6.2.5
P1-45▲	GR2	Gear Ratio (Denominator) (M)	1	pulse	O	O			6.2.5
P2-60▲	GR4	Gear Ratio (Numerator) (N2)	1	pulse	O	O			-
P2-61▲	GR5	Gear Ratio (Numerator) (N3)	1	pulse	O	O			-
P2-62▲	GR6	Gear Ratio (Numerator) (N4)	1	pulse	O	O			-
Register Control Command (PR mode)									
P6-02 ~ P7-27	PO1 ~ PO63	Internal Position Command 1 ~ 63	0	N/A		O			7.10
P5-60 ~ P5-75	POV1 ~ POV15	Target Speed Setting#0 ~ 15	20 ~ 3000	0.1r/m in (rotary motor) 10 ⁻⁶ m/s (linear motor)		O			7.10
P5-03	PDEC	Deceleration Time of Auto Protection	0XF00F FFFF	N/A	O	O	O	O	-
P5-04	HMOV	Homing Mode	0	N/A	O	O			-

Position Control Parameter									
Parameter	Abbr.	Function	Default	Unit	Control Mode				Related Section
					PT	PR	S	T	
P5-05	HSPD1	1 st Speed Setting of High Speed Homing	100	0.1r/m in (rotary motor) 10 ⁻⁶ m/s (linear motor)	O	O	O	O	-
P5-06	HSPD2	2 nd Speed Setting of Low Speed Homing	20	0.1r/m in (rotary motor) 10 ⁻⁶ m/s (linear motor)	O	O	O	O	-
P5-07	PRCM	Trigger Position Command (PR mode only)	0	N/A		O			-
P5-20 ~ P5-35	AC0 ~ AC15	Acceleration/Deceleration Time	200 ~ 30	ms		O			7.10
P5-40 ~ P5-55	DLY0 ~ DLY15	Delay Time after Position Completed	0 ~ 5500	ms		O			7.10
P5-98	EVON	Position Command of Event Rising-edge Trigger	0	N/A		O			-
P5-99	EVOF	Position Command of Event Falling-edge Trigger	0	N/A		O			-
P5-15	PMEM	PATH#1 ~ PATH#2 No Data Retained Setting	0x0	N/A	O	O	O	O	-
P5-16	AXEN	Axis Position - Motor Encoder	N/A	N/A	O	O	O	O	7.3
P5-17	AXPC	Axis Position - Pulse Command	N/A	N/A	O	O	O	O	7.3
P5-18	AXAU	Axis Position - Auxiliary Encoder	N/A	N/A	O	O	O	O	7.3
P5-08	SWLP	Forward Software Limit	+2 ³¹	PUU		O			-
P5-09	SWLN	Reverse Software Limit	-2 ³¹	PUU		O			-

Speed Control Parameter									
Parameter	Abbr.	Function	Default	Unit	Control Mode				Related Section
					PT	PR	S	T	
P1-01●	CTL	Input Setting of Control Mode and Control Command	0	pulse r/min N-M	O	O	O	O	6.1
P1-02▲	PSTL	Speed and Torque (force) Limit Setting	0	N/A	O	O	O	O	6.6
P1-46▲	GR3	Output Pulse Counts Per One Motor Revolution	1	pulse	O	O	O	O	-
P1-55	MSPD	Maximum Speed Limit	rated	r/min (rotary motor) 10^{-3} m/s (linear motor)	O	O	O	O	-
P1-09 ~ P1-11	SP1 ~ 3	Internal Speed Command 1 ~ 3	1000 ~ 3000	0.1r/m in (rotary motor) 10^{-6} m/s (linear motor)			O	O	6.3.1
P1-12 ~ P1-14	TQ1 ~ 3	Internal Torque (force) Limit 1 ~ 3	100	%	O	O	O	O	6.6.2
P1-40▲	VCM	Maximum Speed of Analog Speed Command	rated	r/min (rotary motor) 10^{-3} m/s (linear motor)			O	O	6.3.4
P1-41▲	TCM	Maximum Output of Analog Torque (force) Speed	100	%	O	O	O	O	-
P1-76	AMSPD	Maximum Rotation Setting of Encoder Setting (OA, OB)	5500	r/min (rotary motor) 10^{-3} m/s (linear motor)	O	O	O	O	-

Torque (force) Control Parameter									
Parameter	Abbr.	Function	Default	Unit	Control Mode				Related Section
					PT	PR	S	T	
P1-01●	CTL	Input Setting of Control Mode and Control Command	0	pulse r/min N-M	O	O	O	O	6.1
P1-02▲	PSTL	Speed and Torque (foce) Limit Setting	0	N/A	O	O	O	O	6.6
P1-46▲	GR3	Output Pulse Counts Per One Motor Revolution	1	pulse	O	O	O	O	-
P1-55	MSPD	Maximum Speed Limit	rated	r/min (rotary motor) 10 ⁻³ m/s (linear motor)	O	O	O	O	-
P1-09 ~ P1-11	SP1~3	Internal Speed Limit 1~3	100 ~ 300	0.1r/m in (rotary motor) 10 ⁻⁶ m/s (linear motor)			O	O	6.6.1
P1-12 ~ P1-14	TQ1~3	Internal Torque (force) Command 1~3	100	%	O	O	O	O	6.4.1
P1-40▲	VCM	Maximum Speed of Analog Speed Command	rated	r/min (rotary motor) 10 ⁻³ m/s (linear motor)			O	O	-
P1-41▲	TCM	Maximum Output of Analog Torque (force) Limit	100	%	O	O	O	O	6.4.4

Planning of Digital Input / Output Pin and Output Setting Parameter									
Parameter	Abbr.	Function	Default	Unit	Control Mode				Related Section
					PT	PR	S	T	
P2-09	DRT	DI Debouncing Time	2	2ms	○	○	○	○	-
P2-10	DI1	DI1 Functional Planning	101	N/A	○	○	○	○	Table 8.1
P2-11	DI2	DI2 Functional Planning	104	N/A	○	○	○	○	Table 8.1
P2-12	DI3	DI3 Functional Planning	116	N/A	○	○	○	○	Table 8.1
P2-13	DI4	DI4 Functional Planning	117	N/A	○	○	○	○	Table 8.1
P2-14	DI5	DI5 Functional Planning	102	N/A	○	○	○	○	Table 8.1
P2-15	DI6	DI6 Functional Planning	22	N/A	○	○	○	○	Table 8.1
P2-16	DI7	DI7 Functional Planning	23	N/A	○	○	○	○	Table 8.1
P2-17	DI8	DI8 Functional Planning	21	N/A	○	○	○	○	Table 8.1
P2-36	EDI9	DI9 Functional Planning	0	N/A	○	○	○	○	Table 8.1
P2-37	EDI10	DI10 Functional Planning	0	N/A	○	○	○	○	Table 8.1
P2-38	EDI11	DI11 Functional Planning	0	N/A	○	○	○	○	Table 8.1
P2-39	EDI12	DI12 Functional Planning	0	N/A	○	○	○	○	Table 8.1
P2-40	EDI13	DI13 Functional Planning	0	N/A	○	○	○	○	Table 8.1
P2-41	EDI14	DI14 Functional Planning	0	N/A	○	○	○	○	Table 8.1
P2-18	DO1	DO1 Functional Planning	101	N/A	○	○	○	○	Table 8.2
P2-19	DO2	DO2 Functional Planning	103	N/A	○	○	○	○	Table 8.2
P2-20	DO3	DO3 Functional Planning	109	N/A	○	○	○	○	Table 8.2
P2-21	DO4	DO4 Functional Planning	105	N/A	○	○	○	○	Table 8.2
P2-22	DO5	DO5 Functional Planning	7	N/A	○	○	○	○	Table 8.2

Planning of Digital Input / Output Pin and Output Setting Parameter									
Parameter	Abbr.	Function	Default	Unit	Control Mode				Related Section
					PT	PR	S	T	
P1-38	ZSPD	Zero Speed Range Setting	100	0.1r/m in (rotary motor) 10 ⁻³ m/s (linear motor)	O	O	O	O	Table 8.2
P1-39	SSPD	Target Motor Detection Level	3000	0.1r/m in (rotary motor) 10 ⁻³ m/s (linear motor)	O	O	O	O	Table 8.2
P1-42	MBT1	Enable Delay Time of Brake	0	ms	O	O	O	O	6.5.5
P1-43	MBT2	Disable Delay Time of Brake	0	ms	O	O	O	O	6.5.5
P1-47	SCPD	Speed Reached (DO : SP_OK) Range	10	r/min (rotary motor) 10 ⁻³ m/s (linear motor)			O		Table 8.2
P1-54	PER	Position Completed Range	12800	pulse	O	O			Table 8.2
P1-56	OVW	Output Overload Level Warning	120	%	O	O	O	O	Table 8.2

Communication Parameter									
Parameter	Abbr.	Function	Default	Unit	Control Mode				Related Section
					PT	PR	S	T	
P3-00●	ADR	Address Setting	0x01	N/A	O	O	O	O	9.2
P3-01	BRT	Transmission Speed	0x3203	bps	O	O	O	O	9.2
P3-02	PTL	Communication Protocol	6	N/A	O	O	O	O	9.2
P3-03	FLT	Communication Error Disposal	0	N/A	O	O	O	O	9.2
P3-04	CWD	Communication Timeout	0	sec	O	O	O	O	9.2
P3-05	CMM	Communication Mechanism	0	N/A	O	O	O	O	9.2
P3-06■	SDI	Control Switch of Digital Input (DI)	0	N/A	O	O	O	O	9.2
P3-07	CDT	Communication Response Delay Time	0	1ms	O	O	O	O	9.2
P3-08	MNS	Monitor Mode	0000	N/A	O	O	O	O	9.2
P3-09	SYC	CANopen Synchronize Setting	0x57A1	N/A	O	O	O	O	9.2

Diagnosis Parameter									
Parameter	Abbr.	Function	Default	Unit	Control Mode				Related Section
					PT	PR	S	T	
P4-00★	ASH1	Fault Record (N)	0	N/A	O	O	O	O	4.4.1
P4-01★	ASH2	Fault Record (N-1)	0	N/A	O	O	O	O	4.4.1
P4-02★	ASH3	Fault Record (N-2)	0	N/A	O	O	O	O	4.4.1
P4-03★	ASH4	Fault Record (N-3)	0	N/A	O	O	O	O	4.4.1
P4-04★	ASH5	Fault Record (N-4)	0	N/A	O	O	O	O	4.4.1
P4-05	JOG	Servo Motor Jog Control	20	r/min (rotary motor) 10 ⁻³ m/s (linear motor)	O	O	O	O	4.4.2
P4-06▲■	FOT	Digital Output Register (Readable and Writable)	0	N/A	O	O	O	O	4.4.4
P4-07	ITST	Multi-function of Digital Input	0	N/A	O	O	O	O	4.4.5 9.2
P4-08★	PKEY	Input Status of the Drive Keypad	N/A	N/A	O	O	O	O	-
P4-09★	MOT	Digital Output Status	N/A	N/A	O	O	O	O	4.4.6
P4-10▲	CEN	Adjustment Selection	0	N/A	O	O	O	O	-

Diagnosis Parameter									
Parameter	Abbr.	Function	Default	Unit	Control Mode				Related Section
					PT	PR	S	T	
P4-11	SOF1	Analog Speed Input Offset Adjustment 1	Factory Setting	N/A	O	O	O	O	-
P4-12	SOF2	Analog Speed Input Offset Adjustment 2	Factory Setting	N/A	O	O	O	O	-
P4-13	TOF1	Analog Torque (force) Input Offset Adjustment 1	Factory Setting	N/A	O	O	O	O	-
P4-14	TOF2	Analog Torque (force) Input Offset Adjustment 2	Factory Setting	N/A	O	O	O	O	-
P4-15	COF1	Current Detector (V1 Phase) Offset Adjustment	Factory Setting	N/A	O	O	O	O	-
P4-16	COF2	Current Detector (V2 Phase) Offset Adjustment	Factory Setting	N/A	O	O	O	O	-
P4-17	COF3	Current Detector (W1 Phase) Offset Adjustment	Factory Setting	N/A	O	O	O	O	-
P4-18	COF4	Current Detector (W2 Phase) Offset Adjustment	Factory Setting	N/A	O	O	O	O	-
P4-19	TIGB	IGBT NTC Adjustment Detection Level	Factory Setting	N/A	O	O	O	O	-
P4-20	DOF1	Offset Adjustment Value of Analog Monitor Output (Ch1)	0	mV	O	O	O	O	6.4.4
P4-21	DOF2	Offset Adjustment Value of Analog Monitor Output (Ch2)	0	mV	O	O	O	O	6.4.4
P4-22	SAO	Analog Speed Input OFFSET	0	mV			O		-
P4-23	TAO	Analog Torque (force) Input OFFSET	0	mV				O	-

Motor Parameter							
Parameter	Abbr.	Function	Default	Unit	Applicable Motor		Related section
					SPM	LM	
PM-00		Motor Type	0	N/A	O	O	-
PM-01		Automatic Identification of Motor Parameter	0	N/A	O	O	-
PM-02		Confirmation of Motor Parameter	0	N/A	O	O	-
PM-03		Encoder Type	0x0100	N/A	O	O	-

Motor Parameter							
Parameter	Abbr.	Function	Default	Unit	Applicable Motor		Related section
					SPM	LM	
PM-04		Encoder Resolution	2500	Rotary motor: Pulse/rev (square wave digital signal) Periods/rev (Sinusoid analog signal) Linear motor: $10^{-5}\mu\text{m}/\text{period}$ (square wave digital signal) $10^{-3}\mu\text{m}/\text{period}$ (Sinusoid analog signal)	O	O	-
PM-05		The Interpolation of Signal Converter Box	11	N/A	O	O	-
PM-06		UVW Phase Sequence and Hall Sensor	0	N/A	O	O	-
PM-07		Offset Angle of Hall Sensor	0	0.1°	O	O	-
PM-08		Hysteresis Width of Hall Sensor Moving Back and Forth	0	0.1°	O	O	-
PM-09		Correction of Electrical Angle When Reached Z Axis	0X11	N/A	O	O	-
PM-10		Offset Angle of Z Signal	0	0.1°	O	O	-
PM-11		Current of Magnetic Field Detection When Power On	100	%	O	O	-
PM-12		Condition of Magnetic Field Detection When Power On	0X44	N/A	O	O	-
PM-13		Reserved	0	N/A	O	O	-
PM-14		Reserved	0	N/A	O	O	-
PM-15		Proportional Gain of Current Loop	0	0.001	O	O	-
PM-16		Integral Gain of Current Loop	0	N/A	O	O	-
PM-17		Reserved					
PM-18		Reserved					

Motor Parameter							
Parameter	Abbr.	Function	Default	Unit	Applicable Motor		Related section
					SPM	LM	
PM-19		Overload Gain (Temperature Rises)	100	%	<input type="checkbox"/>	<input type="checkbox"/>	-
PM-20		Overload Gain (Temperature Falls)	100	%	<input type="checkbox"/>	<input type="checkbox"/>	-
PM-21		Cogging Compensation	0X1A00	N/A	<input type="checkbox"/>	<input type="checkbox"/>	-
PM-22		Motor Temperature Sensor	0	N/A	<input type="checkbox"/>	<input type="checkbox"/>	-
PM-23		Reserved	0	N/A	<input type="checkbox"/>	<input type="checkbox"/>	-
PM-24		Reserved	0	N/A	<input type="checkbox"/>	<input type="checkbox"/>	-
PM-25		Reserved	0	N/A	<input type="checkbox"/>	<input type="checkbox"/>	-
PM-26		Reserved (FOR BARCODE)	0	N/A	<input type="checkbox"/>	<input type="checkbox"/>	-
PM-27		Reserved (FOR BARCODE)	0	N/A	<input type="checkbox"/>	<input type="checkbox"/>	-
PM-28		PM Motor Poles	2	pole	<input type="checkbox"/>		-
PM-29		PM Motor Rated Current	30	0.01A	<input type="checkbox"/>		-
PM-30		The Max. Current of PM Motor	100	0.01A	<input type="checkbox"/>		-
PM-31		PM Motor Rated Speed	3000	RPM	<input type="checkbox"/>		-
PM-32		The Max. Speed of PM Motor	5000	RPM	<input type="checkbox"/>		-
PM-33		PM Motor Torque (force) Constant	0	0.01 Nm / A	<input type="checkbox"/>		-
PM-34		PM Motor Inertia	0	10^{-7} kg.m ²	<input type="checkbox"/>		-
PM-35		PM Motor Phase Resistance	0	0.001ohm	<input type="checkbox"/>		-
PM-36		PM Motor Phase Inductance	0	0.01 mH	<input type="checkbox"/>		-
PM-37		Reserved					
PM-38		PM Motor Back EMF Constant	0	10^{-4} Volt/rpm	<input type="checkbox"/>		-
PM-39		Reserved	0	N/A	<input type="checkbox"/>		-
PM-40		Reserved	0	N/A	<input type="checkbox"/>		-
PM-41		Reserved	0	N/A	<input type="checkbox"/>		-
PM-42		Reserved	0	N/A	<input type="checkbox"/>		-

Motor Parameter							
Parameter	Abbr.	Function	Default	Unit	Applicable Motor		Related section
					SPM	LM	
PM-43		Reserved	0	N/A	O		-
PM-44		Reserved	0	N/A	O		-
PM-45		Linear Motor Pole Pitch	0	0.1mm /360°		O	-
PM-46		Linear Motor Rated Current	30	0.01A		O	-
PM-47		Max. Current of Linear Motor	100	0.01A		O	-
PM-48		Max. Speed of Linear Motor	5000	10 ⁻³ m/s		O	-
PM-49		Force Constant of Linear Motor	0	0.01N / A		O	-
PM-50		Linear Motor Phase Resistance	0	0.001ohm		O	-
PM-51		Linear Motor Phase Inductance	0	0.01mh		O	-
PM-52		Reserved					
PM-53		Linear Motor Back EMF Constant	0	10 ⁻¹ Volt/(m/s)		O	-

8.3 Parameter Description

P0-xx Monitor Parameters

P0-00★	VER	Firmware Version	Address: 0000H 0001H
	Operational Interface :	Panel / Software	Communication
	Default :	Factory Setting	
	Control Mode :	ALL	
	Unit :	-	
	Range :	-	
	Data Size :	16bit	
	Format :	DEC	

Settings : This parameter shows the firmware version of the servo drive.

P0-01■	ALE	Alarm Code Display of Drive (Seven-segment Display)	Address: 0002H 0003H
	Operational Interface :	Panel / Software	Communication
	Default :	-	
	Control Mode :	ALL	
	Unit :	-	
	Range :	0x0000~0xFFFF: It only can be set to 0 to clear the alarm (Same as DI.ARST).	
	Data Size :	16bit	
	Format :	BCD	

Settings : Hexadecimal format: displays the alarm code

Alarm of Servo Drive

001 : Over current

002 : Over voltage

003 : Under voltage (In default setting, the alarm occurs only when the voltage is not enough in Servo ON status; In Servo ON status, when it applies to power R, S, T, the alarm still will not be cleared. Please refer to P2-66.)

004 : Motor combination error (The drive corresponds to the wrong motor)

005 : Regeneration error

- 006 : Over load
- 007 : Over speed
- 008 : Abnormal pulse command
- 009 : Excessive deviation of position command
- 010 : Reserved
- 011 : Encoder error (The servo drive cannot connect to the encoder because of disconnection or abnormal wiring)
- 012 : Adjustment error
- 013 : Emergency stop
- 014 : Reverse limit error
- 015 : Forward limit error
- 016 : IGBT overheat
- 017 : Abnormal EEPROM
- 018 : Abnormal signal output
- 019 : Serial communication error
- 020 : Serial communication time out
- 021 : Reserved
- 022 : Main circuit power lack phase
- 023 : Early warning for overload
- 024 : Encoder initial magnetic field error (The magnetic field of the encoder U,V, W signal is in error)
- 025 : The internal of the encoder is in error. (The internal memory of the encoder and the internal counter are in error)
- 026 : Unreliable internal data of the encoder
- 027 : Encoder reset error
- 030 : Motor crash error
- 031 : Incorrect wiring of the motor power line U, V, W (Incorrect wiring of the motor power line U, V, W, GND)
- 033 : Connection of 26 pin on converter box is breakdown
- 040 : Excessive deviation of full closed-loop position control
- 041 : Communication of CN5 is breakdown
- 044 : Warning of servo drive function overload
- 050 : Auto detection of motor parameters is completed
- 051 : Auto detection of motor parameters is in error.
- 052 : Initial magnetic pole detection error

- 053 : Motor parameter is not confirmed
- 054 : Exceeding the range of motor parameter
- 055 : Motor magnetic field is abnormal
- 057 : Feedback pulse is lost
- 058 : Excessive deviation of initial magnetic pole detection position when power on
- 099 : DSP firmware upgrade
- Alarm of CANopen Communication
- 111 : CANopen SDO receives buffer overflow
- 112 : CANopen PDO receives buffer overflow
- 121 : Index error occurs when accessing CANopen PDO
- 122 : Sub-Index error occurs when accessing CANopen PDO
- 123 : Data size error occurs when accessing CANopen PDO
- 124 : Data range error occurs when accessing CANopen PDO
- 125 : CANopen PDO mapping object is read-only and write-protected.
- 126 : CANopen PDO mapping object is not allowed in PDO
- 127 : CANopen PDO mapping object is write-protected when Servo ON
- 128 : Error occurs when reading CANopen PDO mapping object via EEPROM
- 129 : Error occurs when writing CANopen PDO mapping object via EEPROM
- 130 : The accessing address of EEPROM is out of range when using CANopen PDO mapping object
- 131 : CRC of EEPROM calculation error occurs when using CANopen PDO mapping object
- 132 : Enter the incorrect password when using CANopen PDO mapping object
- Alarm of Motion Control
- 201 : An error occurs when loading CANopen data
- 213 ~ 219 : An error occurs when writing parameter via PR procedure. Please refer to Chapter 11 of the manual for further information.
- 235 : PR command overflows
- 245 : PR positioning is over time
- 249 : The number of PR command exceeds the range
- 261 : Index error occurs when accessing CANopen object

- 263 : Sub-Index error occurs when accessing CANopen object
- 265 : Data size error occurs when accessing CANopen object
- 267 : Data range error occurs when accessing CANopen
- 269 : CANopen object is read-only and write-protected
- 26b : CANopen object is not allowed in PDO
- 26d : CANopen object is write-protected when Servo ON
- 26F : Error occurs when reading CANopen object via EEPROM
- 271 : Error occurs when writing CANopen object via EEPROM
- 273 : The accessing address of EEPROM is out of range when using CANopen object
- 275 : CRC of EEPROM calculation error occurs when using CANopen object
- 277 : Enter the incorrect password when using CANopen object
- 283 : Forward software limit
- 285 : Reverse software limit
- 289 : Feedback position counter overflows
- 291 : Servo OFF error
- 301 : CANopen fails to synchronize
- 302 : The synchronized signal of CANopen is sent too fast
- 303 : The synchronized signal of CANopen is sent too slow
- 304 : CANopen IP command is failed
- 305 : SYNC Period is in error
- 380 : Position Deviation Alarm of DO.MC_OK. Please refer to parameter P1-48.

P0-02	STS	Drive Status		Address: 0004H 0005H
Operational Interface :	Panel / Software	Communication		Related Section: 7.2
Default :	00			
Control Mode :	ALL			
Unit :	-			
Range :	00 ~ 127			
Data Size :	16bit			
Format :	DEC			

- Settings :
- 00 : Motor feedback pulse number (after the scaling of electronic gear ratio) [PUU]
 - 01 : Input pulse number of pulse command (after the scaling of electronic gear ratio) [PUU]
 - 02 : Deviation between control command pulse and feedback pulse number[PUU]
 - 03 : The number of motor feedback pulse [Encoder unit, 1,280,000 Pulse/rev]
 - 04 : Distance to command terminal (Encoder unit) [Pulse]
 - 05 : Error pulse number (after the scaling of electronic gear ratio) (Encoder unit) [Pulse]
 - 06 : The frequency of pulse command input [Kpps]
 - 07 : Motor speed
[Permanent magnet synchronous rotary motor: r/min;
Permanentmagnet synchronous linear motor: m/s]
 - 08 : Speed command input [Volt]
 - 09 : Speed command input
[Permanent magnet synchronous rotary motor: r/min;
Permanentmagnet synchronous linear motor: m/s]
 - 10 : Torque (force) command input [Volt]
 - 11 : Torque (force) command input [%]
 - 12 : Average torque [%]
 - 13 : Peak torque [%]
 - 14 : Main circuit voltage (BUS voltage) [Volt]
 - 15 : Load/motor inertia ratio [0.1times]
 - 16 : IGBT temperature
 - 17 : The frequency of resonance suppression
 - 18 : The distance from the current position to Z. The range of the value is between -5000 and +5000;

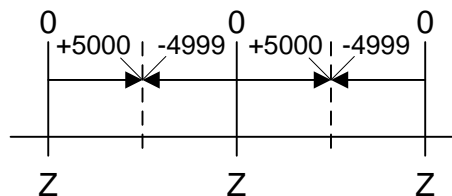

The interval of the two Z-phase pulse command is 10000 Pulse.

- 19 : Mapping Parameter #1 : P0 - 25
- 20 : Mapping Parameter #2 : P0 - 26
- 21 : Mapping Parameter #3 : P0 - 27

22 : Mapping Parameter #4 : P0 - 28

23 : Monitor Variable #1 : P0 - 09

24 : Monitor Variable #2 : P0 - 10

25 : Monitor Variable #3 : P0 - 11

26 : Monitor Variable #4 : P0 - 12

38 : It display the battery voltage [0.1 Volt]. For example, if it displays 36, it means the battery voltage is 3.6 V.

P0-03	MON	Analog Output Monitor		Address: 0006H 0007H	
	Operational Interface :	Panel / Software	Communication	Related Section:	6.6.4
	Default :	00			
	Control Mode :	ALL			
	Unit :	-			
	Range :	00 ~ 0x77			
	Data Size :	16bit			
	Format :	HEX			

Settings :

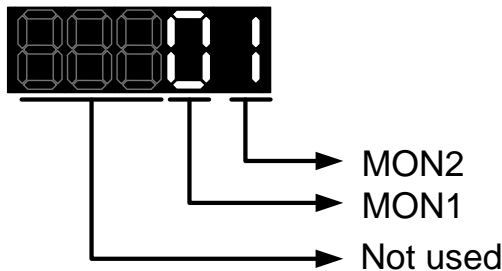

MON1, MON2 Setting Value	Description
0	Motor speed (+/-8 Volts/Max. speed)
1	Motor torque (force) (+/-8 Volts/Max. torque (force))
2	Pulse command frequency (+8 Volts / 4.5Mpps)
3	Speed command (+/-8 Volts/ Max. speed command)
4	Torque (force) command (+/-8 Volts/Max. torque (force) command)
5	VBUS voltage (+/-8 Volts / 450V)
6	Reserved
7	Reserved

Note : Please refer to parameter P1-04, P1-05 for proportional setting of analog output voltage.

For example: P0-03 = 01 (MON1 is the analog output of motor speed; MON2 is the analog output of motor torque (force))

$$\text{MON1 output voltage} = 8 \times \frac{\text{Motor speed}}{(\text{Max. speed} \times \frac{P1-04}{100})} \text{ (unit : Volts)}$$

$$\text{MON2 output voltage} = 8 \times \frac{\text{Motor torque}}{(\text{Max. torque (force)} \times \frac{P1-05}{100})}$$

(unit: Volts)

P0-04 ■	Reserved	Address: 0008H 0009H
----------------	----------	-------------------------

P0-05 ■	Reserved	Address: 000AH 000BH
----------------	----------	-------------------------

P0-06 ■	Reserved	Address: 000CH 000DH
----------------	----------	-------------------------

P0-07 ■	Reserved	Address: 000EH 000FH
----------------	----------	-------------------------

P0-08 ★	TSON	Power On Time	Address: 0010H 0011H
	Operational Interface :	Panel / Software Communication	Related Section : -
	Default :	0	
	Control Mode :	-	
	Unit :	Hour	
	Range :	0 ~ 65535	
	Data Size :	16bit	
	Format :	DEC	

Settings : It shows the total startup time of the servo drive.

P0-09★

CM1	Status Monitor Register 1		Address: 0012H 0013H
Operational Interface :	Panel / Software	Communication	Related Section: 4.3.5
Default :	-		
Control Mode :	ALL		
Unit :	-		
Range :	-		
Data Size :	32bit		
Format :	DEC		

Settings : The setting value which is set by P0-17 should be monitored via P0-09. (Please refer to Chapter 7.2.1, Description of Monitor Variable for the setting value.)

For example, if P0-17 is set to 3, when accessing P0-09, it obtains the total feedback pulse number of motor encoder. For MODBUS communication, two 16bit data, 0012H and 0013H will be read as a 32bit data; (0013H : 0012H) = (Hi-word : Low-word).

Set P0-02 to 23, the panel displays **VAR-1** first, and then shows the content of P0-09.

P0-10★

CM2	Status Monitor Register 2		Address: 0014H 0015H
Operational Interface :	Panel / Software	Communication	Related Section: 4.3.5
Default :	-		
Control Mode :	ALL		
Unit :	-		
Range :	-		
Data Size :	32bit		
Format :	DEC		

Settings : The setting value which is set by P0-18 should be monitored via P0-10. (Please refer to Chapter 7.2.1, Description of Monitor Variable for the setting value.) Set P0-02 to 24, the panel displays **VAR-2** first, and then shows the content of P0-10.

P0-11★	CM3	Status Monitor Register 3		Address: 0016H 0017H
	Operational Interface :	Panel / Software	Communication	Related Section: 4.3.5
	Default :	-		
	Control Mode :	ALL		
	Unit :	-		
	Range :	-		
	Data Size :	32bit		
	Format :	DEC		

Settings : The setting value which is set by P0-19 should be monitored via P0-11. (Please refer to Chapter 7.2.1, Description of Monitor Variable for the setting value.) Set P0-02 to 25, the panel displays **VAR-3** first, and then shows the content of P0-11.

P0-12★	CM4	Status Monitor Register 4		Address: 0018H 0019H
	Operational Interface :	Panel / Software	Communication	Related Section: 4.3.5
	Default :	-		
	Control Mode :	ALL		
	Unit :	-		
	Range :	-		
	Data Size :	32bit		
	Format :	DEC		

Settings : The setting value which is set by P0-20 should be monitored via P0-12. (Please refer to Chapter 7.2.1, Description of Monitor Variable for the setting value.) Set P0-02 to 26, the panel displays **VAR-4** first, and then shows the content of P0-12.

P0-13★	CM5	Status Monitor Register 5		Address: 001AH 001BH
	Operational Interface :	Panel / Software	Communication	Related Section: 4.3.5
	Default :	-		
	Control Mode :	ALL		
	Unit :	-		

Range :	-
Data Size :	32bit
Format :	DEC

Settings : The setting value which is set by P0-21 should be monitored via P0-13. (Please refer to Chapter 7.2.1, Description of Monitor Variable for the setting value.)

P0-14	Reserved	Address: 001CH 001DH
--------------	-----------------	---------------------------------

P0-15	Reserved	Address: 001EH 001FH
--------------	-----------------	---------------------------------

P0-16	Reserved	Address: 0020H 0021H
--------------	-----------------	---------------------------------

P0-17	CM1A	Status Monitor Register 1 Selection	Address: 0022H 0023H
--------------	-------------	--	---------------------------------

Operational Interface :	Panel / Software	Communication	Related Section: -
Default :	0		
Control Mode :	-		
Unit :	-		
Range :	0 ~ 127		
Data Size :	16bit		
Format :	DEC		

Settings : Please refer to Chapter 7.2.1, Description of Monitor Variable for the setting value.

For example:

If P0-17 is set to 07, then reading P0-09 means reading 「 Motor speed (r/min) 」 .

P0-18	CM2A	Status Monitor Register 2 Selection	Address: 0024H 0025H
--------------	-------------	--	---------------------------------

Operational Interface :	Panel / Software	Communication	Related Section: -
Default :	0		
Control Mode :	-		
Unit :	-		

Range :	0 ~ 127
Data Size :	16bit
Format :	DEC

Settings : Please refer to Chapter 7.2.1, Description of Monitor Variable for the setting value.

P0-19	CM3A	Status Monitor Register 3 Selection		Address:0026H 0027H
	Operational Interface :	Panel / Software	Communication	Related Section: -
	Default :	0		
	Control Mode :	-		
	Unit :	-		
	Range :	0 ~ 127		
	Data Size :	16bit		
	Format :	DEC		

Settings : Please refer to Chapter 7.2.1, Description of Monitor Variable for the setting value.

P0-20	CM4A	Status Monitor Register 4 Selection		Address: 0028H 0029H
	Operational Interface :	Panel / Software	Communication	Related Section: -
	Default :	0		
	Control Mode :	-		
	Unit :	-		
	Range :	0 ~ 127		
	Data Size :	16bit		
	Format :	DEC		

Settings : Please refer to Chapter 7.2.1, Description of Monitor Variable for the setting value.

P0-21	CM5A	Status Monitor Register 5 Selection		Address: 002AH 002BH
	Operational Interface :	Panel / Software	Communication	Related Section: -
	Default :	0		
	Control Mode :	-		
	Unit :	-		
	Range :	0 ~ 127		
	Data Size :	16bit		
	Format :	DEC		
Settings :	Please refer to Chapter 7.2.1, Description of Monitor Variable for the setting value.			

P0-22	Reserved	Address: 002CH 002DH
--------------	-----------------	---------------------------------

P0-23	Reserved	Address: 002EH 002FH
--------------	-----------------	---------------------------------

P0-24	Reserved	Address: 0030H 0031H
--------------	-----------------	---------------------------------

P0-25	MAP1	Mapping Parameter # 1		Address: 0032H 0033H
	Operational Interface :	Panel / Software	Communication	Related Section: 4.3.5
	Default :	No need to initialize		
	Control Mode :	ALL		
	Unit :	-		
	Range :	determined by the corresponding parameter of P0-35		
	Data Size :	32bit		
	Format :	HEX		
Settings :	Users can rapidly continuously read and write parameters that are not in the same group. The content of parameter that is specified by P0-35 will be shown in P0-25. Please refer to the description of P0-35 for parameter setting.			

P0-26	MAP2	Mapping Parameter # 2	Address: 0034H 0035H
Operational Interface :	Panel / Software	Communication	Related Section: 4.3.5
Default :	No need to initialize		
Control Mode :	ALL		
Unit :	-		
Range :	determined by the corresponding parameter of P0-36		
Data Size :	32bit		
Format :	HEX		
Settings :	The using method is the same as P0-25. The mapping target is set by parameter P0-36.		

P0-27	MAP3	Mapping Parameter # 3	Address: 0036H 0037H
Operational Interface :	Panel / Software	Communication	Related Section: 4.3.5
Default :	No need to initialize		
Control Mode :	ALL		
Unit :	-		
Range :	determined by the corresponding parameter of P0-37		
Data Size :	32bit		
Format :	HEX		
Settings :	The using method is the same as P0-25. The mapping target is set by parameter P0-37.		

P0-28	MAP4	Mapping Parameter # 4	Address: 0038H 0039H
Operational Interface :	Panel / Software	Communication	Related Section: 4.3.5
Default :	No need to initialize		
Control Mode :	ALL		
Unit :	-		
Range :	determined by the corresponding parameter of P0-38		
Data Size :	32bit		

Data Size :	32bit
Format :	HEX

Settings : The using method is the same as P0-25. The mapping target is set by parameter P0-38.

P0-29	MAP5	Mapping Parameter # 5	Address: 003AH 003BH
	Operational Interface :	Panel / Software	Communication
	Default :	No need to initialize	
	Control Mode :	ALL	
	Unit :	-	
	Range :	determined by the corresponding parameter of P0-39	
	Data Size :	32bit	
	Format :	HEX	
	Settings :	The using method is the same as P0-25. The mapping target is set by parameter P0-39.	

P0-30	MAP6	Mapping Parameter # 6	Address: 003CH 003DH
	Operational Interface :	Panel / Software	Communication
	Default :	No need to initialize	
	Control Mode :	ALL	
	Unit :	-	
	Range :	determined by the corresponding parameter of P0-40	
	Data Size :	32bit	
	Format :	HEX	
	Settings :	The using method is the same as P0-25. The mapping target is set by parameter P0-40.	

P0-31	MAP7	Mapping Parameter # 7	Address: 003EH 003FH
	Operational Interface :	Panel / Software	Communication
	Default :	No need to initialize	

Control Mode :	ALL
Unit :	-
Range :	determined by the corresponding parameter of P0-41
Data Size :	32bit
Format :	HEX

Settings : The using method is the same as P0-25. The mapping target is set by parameter P0-41.

P0-32	MAP8	Mapping Parameter # 8	Address: 0040H 0041H
	Operational Interface :	Panel / Software	Communication
	Default :	No need to initialize	
	Control Mode :	ALL	
	Unit :	-	
	Range :	determined by the corresponding parameter of P0-42	
	Data Size :	32bit	
	Format :	HEX	

Related Section:
4.3.5

Settings : The using method is the same as P0-25. The mapping target is set by parameter P0-42.

P0-33	Reserved	Address: 0042H 0043H
--------------	-----------------	---------------------------------

P0-34	Reserved	Address: 0044H 0045H
--------------	-----------------	---------------------------------

P0-35	MAP1A	Target Setting of Mapping Parameter P0-25	Address: 0046H 0047H
	Operational Interface :	Panel / Software	Communication
	Default :	0x0	
	Control Mode :	ALL	
	Unit :	-	
	Range :	determined by the communication address of the parameter group	

Related Section:
4.3.5

Data Size :	32bit
Format :	HEX

Settings : Select the data block to access the parameter corresponded by register 1.

The mapping content is 32 bits wide and can map to two 16-bit parameters or one 32-bit parameter.

P0-35:

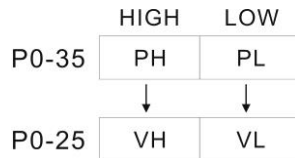

Mapping parameter: P0-35; Mapping content: P0-25.

When PH≠PL, it means the content of P0-25 includes two 16-bit parameters.

VH=*(PH), VL=*(PL)

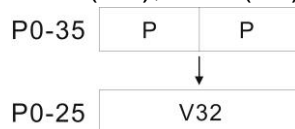

Mapping parameter: P0-35; Mapping content: P0-25.

When PH=PL=P, it means the content of P0-25 includes one 32-bit parameter.

If P=060Ah (parameter P6-10), then V32 is P6-10.

The setting format of PH, PL is:

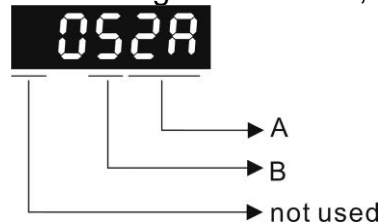

A: The hexadecimal of parameter indexing

B: The hexadecimal of parameter group

For example:

If the mapping target is P2-06, set P0-35 to 0206.

If the mapping target is P5-42, set P0-35 to 052A.

For example:

If users desire to read / write P1-44 (32bit) through P0-25, set P0-35 to 0x012C012C via panel or communication. Then, when reading / writing P0-25, it also reads / writes P1-44.

Moreover, users can also access the value of P2-02 and P2-04 through P0-25.

P2-02 Position feed forward gain (16bit)

P2-04 Speed control gain (16bit)

Users only need to set P0-35 to 0x02040202. Then, when reading / writing P0-25, it also reads / writes the value of P2-02 and P2-04.

P0-36	MAP2A	Target Setting of Mapping Parameter P0-26	Address: 0048H 0049H
Operational Interface :	Panel / Software	Communication	Related Section: 4.3.5
Default :	0x0		
Control Mode :	ALL		
Unit :	-		
Range :	determined by the communication address of the parameter group		
Data Size :	32bit		
Format :	HEX		
Settings :	P0-36 <input type="text"/> ↓ ↓ P0-26 <input type="text"/>		

P0-37	MAP3A	Target Setting of Mapping Parameter P0-27	Address: 004AH 004BH
Operational Interface :	Panel / Software	Communication	Related Section: 4.3.5
Default :	0x0		
Control Mode :	ALL		
Unit :	-		
Range :	determined by the communication address of the parameter group		
Data Size :	32bit		
Format :	HEX		
Settings :	P0-37 <input type="text"/> ↓ ↓ P0-27 <input type="text"/>		

P0-38	MAP4A	Target Setting of Mapping Parameter P0-28	Address: 004CH 004DH
Operational Interface :	Panel / Software	Communication	Related Section: 4.3.5
Default :	0x0		
Control Mode :	ALL		

Unit :	-
Range :	determined by the communication address of the parameter group
Data Size :	32bit
Format :	HEX
Settings :	P0-38 <input type="text"/>
	↓ ↓
	P0-28 <input type="text"/>

P0-39	MAP5A	Target Setting of Mapping Parameter P0-29		Address: 004EH 004FH
	Operational Interface :	Panel / Software	Communication	Related Section: 4.3.5
	Default :	0x0		
	Control Mode :	ALL		
	Unit :	-		
	Range :	determined by the communication address of the parameter group		
	Data Size :	32bit		
	Format :	HEX		
	Settings :	P0-39 <input type="text"/>		
	↓ ↓	P0-29 <input type="text"/>		

P0-40	MAP6A	Target Setting of Mapping Parameter P0-30		Address: 0050H 0051H
	Operational Interface :	Panel / Software	Communication	Related Section: 4.3.5
	Default :	0x0		
	Control Mode :	ALL		
	Unit :	-		
	Range :	determined by the communication address of the parameter group		
	Data Size :	32bit		
	Format :	HEX		
	Settings :	P0-40 <input type="text"/>		
	↓ ↓	P0-30 <input type="text"/>		

P0-41	MAP7A	Target Setting of Mapping Parameter P0-31		Address: 0052H 0053H
	Operational Interface :	Panel / Software	Communication	Related Section: 4.3.5
	Default :	0x0		
	Control Mode :	ALL		
	Unit :	-		
	Range :	determined by the communication address of the parameter group		
	Data Size :	32bit		
	Format :	HEX		
	Settings :	P0-41	<input type="text"/>	
	P0-31	<input type="text"/>		

P0-42	MAP8A	Target Setting of Mapping Parameter P0-32		Address: 0054H 0055H
	Operational Interface :	Panel / Software	Communication	Related Section: 4.3.5
	Default :	0x0		
	Control Mode :	ALL		
	Unit :	-		
	Range :	determined by the communication address of the parameter group		
	Data Size :	32bit		
	Format :	HEX		
	Settings :	P0-42	<input type="text"/>	
	P0-32	<input type="text"/>		

P0-43	Reserved	Address: 0056H 0057H
--------------	-----------------	---------------------------------

P0-44★

PCMN	Status Monitor Register (for PC software)		Address: 0058H 0059H
Operational Interface :	Panel / Software	Communication	Related Section: 4.3.5
Default :	0x0		
Control Mode :	ALL		
Unit :	-		
Range :	determined by the communication address of the parameter group		
Data Size :	32bit		
Format :	DEC		
Settings :	Same as parameter P0-09		

P0-45■

PCMNA	Status Monitor Register Selection (for PC software)		Address: 005AH 005BH
Operational Interface :	Panel / Software	Communication	Related Section: 4.3.5
Default :	0x0		
Control Mode :	ALL		
Unit :	-		
Range :	0~127		
Data Size :	16bit		
Format :	DEC		
Settings :	Same as parameter P0-17		

P0-46★	SVSTS	Servo Digital Output Status Display		Address: 005CH 005DH
	Operational Interface :	Panel / Software	Communication	Related Section: -
	Default :	0		
	Control Mode :	ALL		
	Unit :	-		
	Range :	0x00 ~ 0xFF		
	Data Size :	16bit		
	Format :	HEX		

- Settings :
- Bit0: SRDY (Servo is ready)
 - Bit1: SON (Servo ON)
 - Bit2: ZSPD (Zero speed detection)
 - Bit3: TSPD (Target speed reached)
 - Bit4: TPOS (Target position reached)
 - Bit5: TQL (Torque limit)
 - Bit6: ALRM (Servo alarm)
 - Bit7: BRKR (Brake control output)
 - Bit8: HOME (Homing finished)
 - Bit9: OLW (Early warning for overload)
 - Bit10: WARN (When Servo warning, CW, CCW, EMGS, under voltage, Communication error, etc, occurs, DO is ON)
 - Bit11: Reserved
 - Bit12: Reserved
 - Bit13: Reserved
 - Bit14: Reserved
 - Bit15: Reserved

P1-xx Basic Parameters

P1-00▲	PTT	The Type of External Pulse Input	Address: 0100H 0101H
	Operational Interface :	Panel / Software Communication	Related Section: 6.2.1
	Default :	0x2	
	Control Mode :	PT	
	Unit :	-	
	Range :	0 ~ 0x1132	
	Data Size :	16bit	
	Format :	HEX	

Settings :

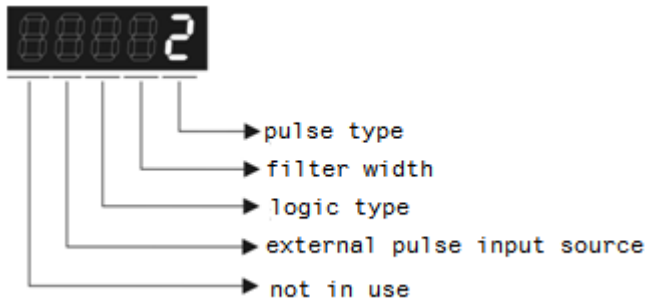

- Pulse Type
 - 0: AB phase pulse (4x)
 - 1: Clockwise (CW) and Counterclockwise (CCW) pulse
 - 2: Pulse + symbol
 - Other setting: reserved

- Filter Width

If the received frequency is much higher than the setting, it will be regarded as the noise and filtered out.

Setting Value	Low-speed filter frequency (Min. pulse width* _{note1})	Setting Value	High-speed filter frequency (Min. pulse width* _{note1})
0	0.83Mpps (600ns)	0	3.33Mpps (150ns)
1	208Kpps (2.4us)	1	0.83Mpps (600ns)
2	104Kpps (4.8us)	2	416Kpps (1.2us)
3	52Kpps (9.6us)	3	208Kpps (2.4us)
4	No filter function	4	No filter function

Note : When the source of external pulse is from the high-speed differential signal and the setting value is 0 (the high-speed filter frequency is 3.33Mpps at the moment), then:

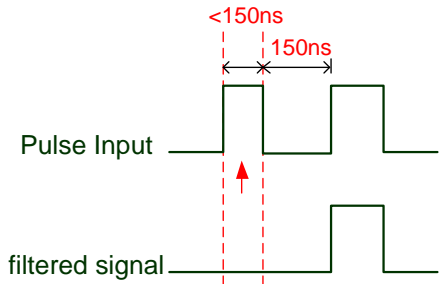

When this pulse width is shorter than 150 ns, it will be regarded as low level. Two input pulse will be seen as one.

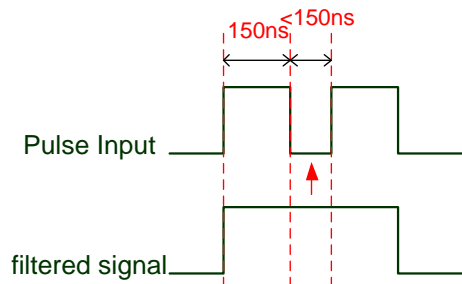

When this pulse width is shorter than 150 ns, it will be regarded as high level. Two input pulse will be seen as one.

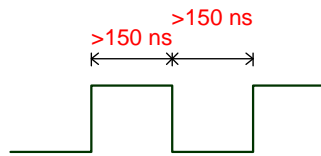

When High, Low duty of the pulse width are longer than 150 ns, it can ensure the pulse command will not be filtered.

If the user uses 2~4 MHz input pulse, it is suggested to set the filter value to 4. Please note that the applicable version is: DSP version 1.036 sub05 and CPLD version above 10.

Note: When the signal is the high-speed pulse specification of 4 Mpps and the settings value of the filter is 4, then pulse will not be filtered.

● Logic Type

Logic		Pulse Type		High-speed and Low-speed pulse input			
				Forward		Reverse	
0	Positive Logic	AB phase pulse		A Pulse Phase Lead		A Pulse Phase Lag	
		CW and CCW pulse					
				High-speed pulse input			
				Forward		Reverse	
		Pulse + Symbol		Sign = high		Sign = low	
				Low-speed pulse input			
				Forward		Reverse	
		Pulse + Symbol		Sign = low		Sign = high	

For digital circuit, it uses 0 and 1 represents two status, which is high voltage and low voltage. In Positive Logic, 1 represents high voltage and 0 represents low voltage and vice versa in Negative Logic.

For example:

Positive Logic

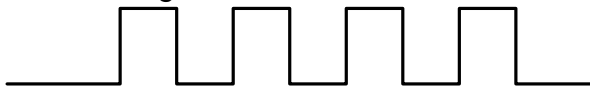

Negative Logic

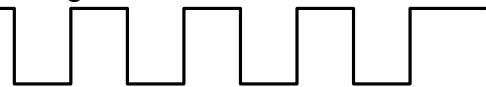

Pulse Specification		Max. Input Frequency	Minimum time width					
			T1	T2	T3	T4	T5	T6
High-speed pulse	Differential Signal	4Mpps	62.5ns	125ns	250ns	200ns	125ns	125ns
Low-speed pulse	Differential Signal	500Kpps	0.5μs	1μs	2μs	2μs	1μs	1μs
	Open-collector	200Kpps	1.25μs	2.5μs	5μs	5μs	2.5μs	2.5μs

Pulse Specification		Max. Input Frequency	Voltage Specification	Forward Current
High-speed pulse	Differential Signal	4Mpps	5V	< 25mA
Low-speed pulse	Differential Signal	500Kpps	2.8V ~ 3.7V	< 25mA
	Open-collector	200Kpps	24V (Max.)	< 25mA

- The Source of External Pulse:
 - 0: Low-speed optical coupler (CN1 Pin: PULSE, SIGN)
 - 1: High-speed differential (CN1 Pin: HPULSE, HSIGN)

P1-01●	CTL	Input Setting of Control Mode and Control Command	Address : 0102H 0103H
	Operational Interface :	Panel / Software	Communication
Default :	0		
Control Mode :	ALL		
Unit :	P (pulse); S (r/min, m/s); T (N-M)		
Range :	00 ~ 0x110F		
Data Size :	16bit		
Format :	HEX		
Settings :			

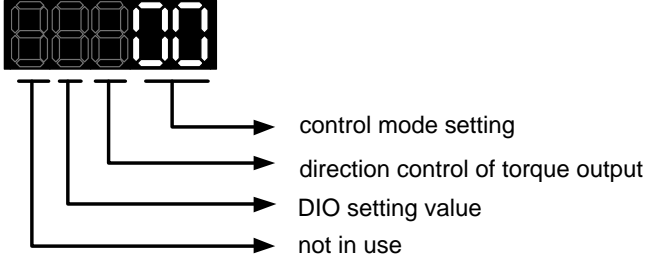

- Control Mode Settings

Mode	PT	PR	S	T	Sz	Tz
Single Mode						
00	▲					
01		▲				
02			▲			
03				▲		
04					▲	
05						▲
Dual Mode						
06	▲		▲			
07	▲			▲		
08		▲	▲			
09		▲		▲		
0A			▲	▲		
0B	CANopen Mode					
0C	Reserved					
0D	▲	▲				
Multiple Mode						
0E	▲	▲	▲			
0F	▲	▲		▲		

PT: Position Control Mode (The command source is external pulse and analog voltage which can be selected via DI. PTAS. Analog voltage can be used soon.)

PR: Position Control Mode (The command source is internal signal which provides 64 positions and can be selected via DI.POS0~POS5.It also provides various ways of Homing.)

S: Speed Control Mode (The command source is the external analog voltage and register. It can be selected via DI. SPD0, SPD1.)

T: Torque (force) Control Mode (The command source is the external analog voltage and register. It can be selected via DI. TCM0, TCM1.)

Sz: Zero Speed / Internal Speed Command

Tz: Zero Torque / Internal Torque Command

- Dual Mode: It can switch mode via the external Digital Input (DI). For example, if it is set to the dual mode of PT/S (Control mode setting: 06), the mode can be switched via DI. S-P (Please refer to table 7.1).
- Multiple Mode: It can switch mode via the external Digital Input (DI). For example, if it is set to multiple mode of PT/PR/S (Control Mode Setting: 12), the mode can be switched via DI. S-P, PT-PR (Please refer to table 7.1).

- Torque (force) Output Direction Settings (Delta's 20bit rotary motor)

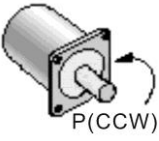
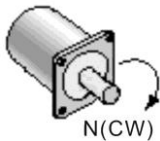
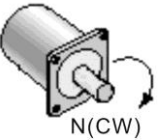
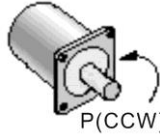
	0	1
Forward		
Reverse		

※If you do not use Delta's 20bit rotary motor, the forward / reverse direction might be different because of the different wiring of UVW.

- Digital Input / Digital Output (DIO) Setting
 - 0: When switching mode, DIO (P2-10 ~ P2-22) remains the original setting value and will not be changed.
 - 1: When switching mode, DIO (P2-10 ~ P2-22) can be reset to the default value of each operational mode automatically.

P1-02▲	PSTL	Speed and Torque (Force) Limit Setting	Address: 0104H 0105H
Operational Interface :	Panel / Software	Communication	Related Section: Section 6.6 Table 8.1
Default :	0		
Control Mode :	ALL		
Unit :	-		
Range :	00 ~ 0x11		
Data Size :	16bit		
Format :	HEX		

Settings :

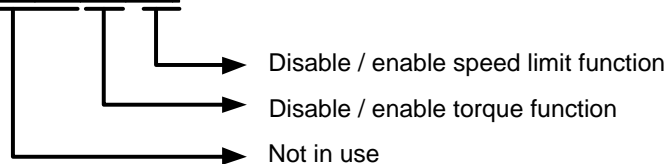
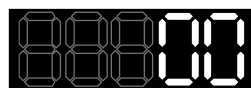

- Disable / enable speed limit function
 - 0: Disable speed limit function
 - 1: Enable speed limit function (it is effective in T mode only)
 - Other: Reserved

Block diagram of speed limit setting:

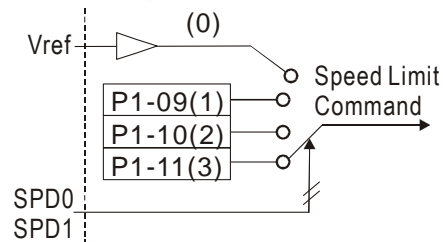

- Disable / enable torque (force) limit function
 - 0: Disable torque (force) limit function
 - 1: Enable torque (force) limit function (it is effective in P/S mode)
 - Other: Reserved

Block diagram of torque limit setting:

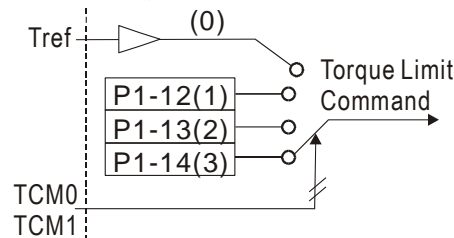

When desiring to use torque limit function, users could use parameter to set this value to 1 and limit the torque for good. Thus, the user can save one DI setting. Also, users could enable or disable the limit function via DI.TRQLM, which is a more flexible way but would need to take one DI setting. Torque limit can be enabled by P1-02 or DI. DI.TCM0 and DI.TCM1 are for selecting the limiting source.

P1-03	AOUT	Polarity Setting of Encoder Pulse Output		Address: 0106H 0107H
	Operational Interface :	Panel / Software	Communication	Related Section: 3.3.3
	Default :	0		
	Control Mode :	ALL		
	Unit :	-		
	Range :	0 ~ 0x13		
	Data Size :	16bit		
	Format :	HEX		

Settings :

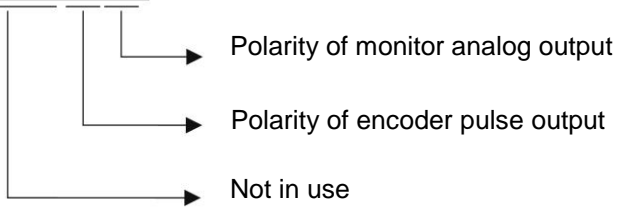

- Polarity of monitor analog output
 - 0: MON1(+), MON2(+)
 - 1: MON1(+), MON2(-)
 - 2: MON1(-), MON2(+)
 - 3: MON1(-), MON2(-)
- Polarity of encoder pulse output
 - 0: Forward output
 - 1: Reverse output

P1-04	MON1	MON1 Analog Monitor Output Proportion		Address: 0108H 0109H
	Operational Interface :	Panel / Software	Communication	Related Section: 6.4.4
	Default :	100		
	Control Mode :	ALL		
	Unit :	% (full scale)		
	Range :	0 ~ 100		
	Data Size :	16bit		
	Format :	DEC		

Settings : Please refer to parameter P0-03 for the setting of analog output selection.

For example:

P0-03 = 0x00 (MON1 is the speed analog output)

When the output voltage value of MON1 is V1:

Motor speed = (Max. speed × V1/8) × P1-04/100

P1-05	MON2	MON2 Analog Monitor Output Proportion		Address: 0108H 0109H
Operational Interface :	Panel / Software	Communication		Related Section: 6.4.4
Default :	100			
Control Mode :	ALL			
Unit :	% (full scale)			
Range :	0 ~ 100			
Data Size :	16bit			
Format :	DEC			

Settings : Please refer to parameter P0-03 for the setting of analog output selection.

For example:

P0-03 = 0x00 (MON2 is the speed analog output)

When the output voltage value of MON2 is V2:

Motor speed = (Max. × V2/8) × P1-05/100

P1-06	SFLT	Analog Speed Command (Low-pass Filter)		Address: 010CH 010DH
Operational Interface :	Panel / Software	Communication		Related Section: 6.3.3
Default :	0			
Control Mode :	S			
Unit :	ms			
Range :	0 ~ 1000 (0: disable this function)			
Data Size :	16bit			
Format :	DEC			

Settings : 0: Disabled

P1-07	TFLT	Analog Torque (Force) Command (Low-pass Filter)	Address: 010EH 010FH
Operational Interface :	Panel / Software	Communication	Related Section: 6.4.3
Default :	0		
Control Mode :	T		
Unit :	ms		
Range :	0 ~ 1000 (0: disable this function)		
Data Size :	16bit		
Format :	DEC		
Settings : 0: Disabled			

P1-08	PFLT	Smooth Constant of Position Command (Low-pass Filter)	Address: 0110H 0111H
Operational Interface :	Panel / Software	Communication	Related Section: 6.2.6
Default :	0		
Control Mode :	PT / PR		
Unit :	10 ms		
Range :	0 ~ 1000		
Data Size :	16bit		
Format :	DEC		
Example :	11 = 110 ms		
Settings : 0: Disabled			

P1-09	SP1	Internal Speed Command 1 / Internal Speed Limit 1	Address: 0112H 0113H
Operational Interface :	Panel / Software	Communication	Related Section: 6.3.1
Default :	1000		
Control Mode :	S / T		

Unit :	Permanent magnet synchronous rotary motor: 0.1rpm Permanent magnet synchronous linear motor: 10 ⁻⁶ m/s
Range :	Permanent magnet synchronous rotary motor: -60000 ~ +60000 Permanent magnet synchronous linear motor: -15999999 ~ 15999999
Data Size :	32bit
Format :	DEC
Example :	Internal speed command: Permanent magnet synchronous rotary motor: 120 = 12 r/min Permanent magnet synchronous linear motor: 1200000=1.2m/s Internal Speed Limit: Positive value and negative value is the same. Please refer to the following description.

Settings : Internal Speed Command 1: The setting of the first internal speed command

Internal Speed Limit 1: The setting of the first internal speed limit

Example of inputting internal speed limit:

Permanent magnet synchronous rotary motor:

Speed limit setting value of P1-09	Allowable Speed Range	Forward Speed Limit	Reverse Speed Limit
1000	-100 ~ 100 r/min	100 r/min	-100 r/min
-1000			

Permanent magnet synchronous linear motor:

Speed limit setting value of P1-09	Allowable Speed Range	Forward Speed Limit	Reverse Speed Limit
100000	-0.1 ~ 0.1 m/s	0.1 m/s	-0.1 m/s
-100000			

P1-10	SP2	Internal Speed Command 2 / Internal Speed Limit 2		Address: 0114H 0115H
	Operational Interface :	Panel / Software	Communication	Related Section: 6.3.1
	Default :	2000		

Control Mode :	S / T
Unit :	Permanent magnet synchronous rotary motor: 0.1rpm Permanent magnet synchronous linear motor: 10^{-6} m/s
Range :	Permanent magnet synchronous rotary motor: -60000 ~ +60000 Permanent magnet synchronous linear motor: -15999999~15999999
Data Size :	32bit
Format :	DEC
Example :	Internal speed command: Permanent magnet synchronous rotary motor: 120 = 12 r/min Permanent magnet synchronous linear motor: 1200000=1.2m/s Internal Speed limit: Positive value and negative value is the same. Please refer to the following description.

Settings : Internal Speed Command 2 : The setting of the second internal speed command

Internal Speed Limit 2: The setting of the second internal speed limit

Example of inputting internal speed limit:

Permanent magnet synchronous rotary motor:

Speed limit setting value of P1-10	Allowable Speed Range	Forward Speed Limit	Reverse Speed Limit
1000	-100 ~ 100 r/min	100 r/min	-100 r/min
-1000			

Permanent magnet synchronous linear motor:

Speed limit setting value of P1-10	Allowable Speed Range	Forward Speed Limit	Reverse Speed Limit
100000	-0.1 ~ 0.1 m/s	0.1 m/s	-0.1 m/s
-100000			

P1-11	SP3	Internal Speed Command 3 / Internal Speed Limit 3		Address: 0116H 0117H
	Operational Interface :	Panel / Software	Communication	Related Section: 6.3.1
	Default :	3000		
	Control Mode :	S / T		
	Unit :	Permanent magnet synchronous rotary motor: 0.1rpm Permanent magnet synchronous linear motor: 10^{-6} m/s		
	Range :	Permanent magnet synchronous rotary motor: -60000 ~ +60000 Permanent magnet synchronous linear motor: -15999999~15999999		
	Data Size :	32bit		
	Format :	DEC		
	Example :	Internal Speed Command: Permanent magnet synchronous rotary motor: 120 = 12 r/min Permanent magnet synchronous linear motor: 1200000=1.2m/s Internal Speed limit: Positive value and negative value is the same. Please refer to the following description.		

Settings : Internal Speed Command 3: The setting of the third internal speed command

Internal Speed Limit 3: The setting of the third internal speed limit

Example of inputting internal speed limit:

Permanent magnet synchronous rotary motor:

Speed limit setting of P1-11	Allowable Speed Range	Forward Speed Limit	Reverse Speed Limit
1000	-100 ~ 100 r/min	100 r/min	-100 r/min
-1000			

Permanent magnet synchronous linear motor:

Speed limit setting of P1-11	Allowable Speed Range	Forward Speed Limit	Reverse Speed Limit
100000	-0.1 ~ 0.1 m/s	0.1 m/s	-0.1 m/s
-100000			

P1-12	TQ1	Internal Torque (Force) Command 1 / Internal Torque (Force) Limit 1		Address: 0118H 0119H
	Operational Interface :	Panel / Software	Communication	Related Section: 6.4.1
	Default :	100		
	Control Mode :	T / P, S		
	Unit :	%		
	Range :	-300 ~ +300		
	Data Size :	16bit		
	Format :	DEC		
	Example :	Internal Torque (Force) Command: 30 = 30 % Internal Torque (Force) Limit: Positive value and negative value is the same. Please refer to the following description.		

Settings : Internal Torque (Force) Command 1: The setting of the first internal torque (force)command

Internal Torque (Force) Limit 1: The setting of the first internal torque (force) limit

Example of inputting internal torque (force) limit:

Torque (force) limit setting value of P1-12	Allowable Torque (force) Range	Forward Torque (force) Limit	Reverse Torque (force) Limit
30	-30 ~ 30 %	30 %	-30 %
-30			

P1-13	TQ2	Internal Torque (Force) Command 2 / Internal Torque (Force) Limit 2		Address: 011AH 011BH
	Operational Interface :	Panel / Software	Communication	Related Section: 6.4.1
	Default :	100		
	Control Mode :	T / P, S		
	Unit :	%		
	Range :	-300 ~ +300		

Data Size :	16bit
Format :	DEC
Example :	Internal Torque (Force) Command: 30 = 30 % Internal Torque (Force) Limit: Positive value and negative value is the same. Please refer to the following description.

Settings : Internal Torque (Force) Command 2: The setting of the second internal torque (force) command

Internal Torque (Force) Limit 2: The setting of the second internal torque (force) limit

Example of inputting internal torque (force) limit:

Torque limit setting value of P1-13	Allowable Torque (force) Range	Forward Torque (force) Limit	Reverse Torque (force) Limit
30	-30 ~ 30 %	30 %	-30 %
-30			

P1-14	TQ3	Internal Torque (Force) Command 3 / Internal Torque (Force) Limit 3		Address: 011CH 011DH
	Operational Interface :	Panel / Software	Communication	Related Section: 6.4.1
	Default :	100		
	Control Mode :	T / P, S		
	Unit :	%		
	Range :	-300 ~ +300		
	Data Size :	16bit		
	Format :	DEC		
	Example :	Internal Torque (Force) Command: 30 = 30 % Internal Torque (Force) Limit: Positive value and negative value is the same. Please refer to the following description.		

Settings : Internal Torque (Force) Command 3: The setting of the third internal torque (force) command

Internal Torque (Force) Limit 3: The setting of the third internal torque (force) limit

Example of inputting internal torque limit:

Torque (force) limit setting value of P1-14	Allowable Torque (force) Range	Forward Torque (force) Limit	Reverse Torque (force) Limit
30	-30 ~ 30 %	30 %	-30 %
-30			

P1-15	CXFT	Capture Synchronous Axis – Threshold of Correction	Address: 011EH 011FH
	Operational Interface :	Panel / Software Communication	Related Section:
	Default :	0000h	
	Control Mode :	ALL	
	Unit :	-	
	Range :	0000h ~ 0x1F5F	
	Data Size :	16bit	
	Format :	HEX	

Settings :

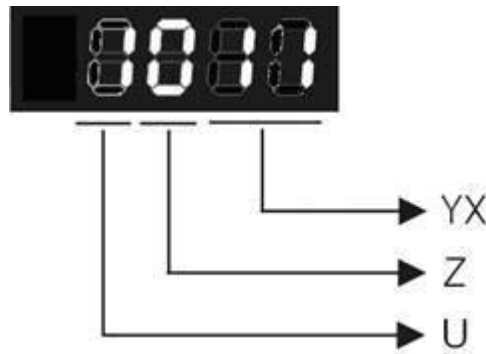

- YX: Threshold of correction (%)
- Z: Filter intensity
- U: Filter is functioning (read-only)

YX: When synchronous axis captures the signal, the system will calculate the error. This function is enabled only when the error is less than the the setting range. Otherwise, the system will use the new threshold of correction to perform the operation.

YX	00	01~05F
Function	Diabled	It will be enabled when error is between 1% and YX%.

Z	0	1~F
Function	Disabled	Average of 2 ^Z : Enabled

Z: The setting of filter intensity (Bigger value brings less severe change and better filter effect)

U: Vaue Definition (read-only):

- 0: Filter function is disabled. It means the error is greater than Y & X Range.
- 1: Filter function is enabled. It means the error is within Y & X range.

If value Z or YX is 0, filter function is disabled.

P1-16	CSOF	Capture Synchronous Axis – Offset Compensation		Address: 0120H 0121H
	Operational Interface :	Panel / Software	Communication	Related Section:
	Default :	0		
	Control Mode :	PR		
	Unit :	Pulse unit of Capture Axis		
	Range :	-32768 ~ +32767		
	Data Size :	16bit		
	Format :	DEC		

Settings : When capture synchronous axis is enabled, if desire to change the synchronous error (P5-79), setting this parameter will do.

Write P1-16: $P5-79 = P5-79 + \text{writing value}$

Read P1-16: $\text{Read value} = P5-79$

- Note :
- 1) The setting value of this parameter is the accumulative value, which will not be influenced by current error value.
 - 2) The value of P5-79 can be monitored by monitoring variable 0x54.

P1-17	TEET	Compensation of Following Error - Additional Time Setting		Address: 0122H 0123H
	Operational Interface :	Panel / Software	Communication	Related Section:
	Default :	0		
	Control Mode :	ALL		
	Unit :	Ms; the smallest unit is usec		
	Range :	-20.000 ~ +20.000 (three decimal point)		
	Data Size :	16bit		
	Format :	DEC		
	Example :	1.5 = Motor speed x 1.5 ms (PUU)		

Settings :

When this function is enabled (P1-36 = 1), the system will make the position error (PUU) close to 0 according to the compensation amount of command. If the time delay is caused by other reasons, users could setup the additional compensation time to compensate the position error.

$$\text{Additional compensation distance} = \text{P1-17} \times \text{Motor speed}$$

Note : 1) Value of P1-36 has to set to 1.

P1-18	Reserved	Address: 0124H 0125H
P1-19	Reserved	Address: 0126H 0127H
P1-20	Reserved	Address: 0128H 0129H
P1-21	Reserved	Address: 012AH 012BH
P1-22	Reserved	Address: 012CH 012DH
P1-23	CMOF COMPARE - Offset Data of CMP (non-volatile)	Address: 012EH 012FH

Operational Interface :	Panel / Software	Communication	Related Section :
Default :	0		
Control Mode :	ALL		
Unit :	Pulse unit of compare source		
Range :	-10000000 ~ +10000000		
Data Size :	32bit		
Format :	DEC		

Settings : The real compared data is offset by this value.

$$\text{CMP_DATA} = \text{DATA_ARRAY[*]} + \text{P1-23} + \text{P1-24}$$

- Note :
- 1) P1-23: Non-volatile parameter
 - 2) P1-24: After setting, if P1-19.Z0 = 1, the value will be 0 automatically.
 - 3) CMP_DATA can be monitored via monitoring variable 0x25.

P1-24	CMOF	COMPARE - Offset Data of CMP (can reset to 0 automatically)		Address: 0130H 0131H
	Operational Interface :	Panel / Software	Communication	Related Section:
	Default :	0		
	Control Mode :	ALL		
	Unit :	Pulse unit of compare source		
	Range :	-32768 ~ +32767		
	Data Size :	16bit		
	Format :	DEC		

Settings : The real compared data is offset by this value.
 $CMP_DATA = DATA_ARRAY[*] + P1-23 + P1-24$

- Note : 1) P1-24: volatile parameter.
 2) After setting, if P1-19.Z0 = 1, the value will be 0 automatically.

P1-25	VSF1	Low-frequency Vibration Suppression (1)		Address: 0132H 0133H
	Operational Interface :	Panel / Software	Communication	Related Section: 6.2.9
	Default :	1000		
	Control Mode :	PT / PR		
	Unit :	0.1 Hz		
	Range :	10 ~ 1000		
	Data Size :	16bit		
	Format :	DEC		
	Example :	150= 15 Hz		

Settings : The setting value of the first low-frequency vibration suppression.
 If P1-26 is set to 0, then it will disable the first low-frequency filter.

P1-26	VSG1	Low-frequency Vibration Suppression Gain (1)		Address: 0134H 0135H
	Operational Interface :	Panel / Software	Communication	Related Section: 6.2.9
Default :	0			

Control Mode :	PT / PR
Unit :	-
Range :	0 ~ 9 (0: Disable the first low-frequency filter)
Data Size :	16bit
Format :	DEC

Settings : The first low-frequency vibration suppression gain. The bigger value it is, the better the position response will be. However, if the value is set too big, the motor will not be able to smoothly operate. It is suggested to set the value to 1.

P1-27	VSF2	Low-frequency Vibration Suppression (2)		Address: 0136H 0137H
	Operational Interface :	Panel / Software	Communication	Related Section: 6.2.9
	Default :	1000		
	Control Mode :	PT / PR		
	Unit :	0.1 Hz		
	Range :	10 ~ 1000		
	Data Size :	16bit		
	Format :	DEC		
	Example :	150 = 15 Hz		

Settings : The setting value of the second low-frequency vibration suppression. If P1-28 is set to 0, then it will disable the second low-frequency filter.

P1-28	VSG2	Low-frequency Vibration Suppression Gain (2)		Address: 0138H 0139H
	Operational Interface :	Panel / Software	Communication	Related Section: 6.2.9
	Default :	0		
	Control Mode :	PT / PR		
	Unit :	-		
	Range :	0 ~ 9 (0: Disable the second low-frequency filter)		
	Data Size :	16bit		
	Format :	DEC		

Settings : The second low-frequency vibration suppression gain. The bigger value it is, the better the position response will be. However, if the value is set too big, the motor will not be able to smoothly operate. It is suggested to set the value to 1.

P1-29	AVSM	Auto Low-frequency Vibration Supression Setting	Address: 013AH 013BH
Operational Interface :	Panel / Software	Communication	Related Section: 6.2.9
Default :	0		
Control Mode :	PT / PR		
Unit :	-		
Range :	0 ~ 1		
Data Size :	16bit		
Format :	DEC		

Settings : 0: The function is disabled.

1: The value will set back to 0 after vibration suppression.

Description of Auto Mode Setting:

When the parameter is set to 1, it is in auto suppression. When the vibration frequency is not being detected or the value of searched frequency is stable, the parameter will set to 0 and save the low-frequency vibration suppression to P1-25 automatically.

P1-30	VCL	Low-frequency Vibration Detection	Address: 013CH 013DH
Operational Interface :	Panel / Software	Communication	Related Section: 6.2.9
Default :	500		
Control Mode :	PT / PR		
Unit :	Pulse		
Range :	1 ~ 8000		
Data Size :	16bit		
Format :	DEC		

Settings : When enabling the auto suppression (P1-29 = 1), it will automatically search the detection level. The lower the value is, the more sensitive the detection will be. However, it is easy to misjudge the noise or regard the other low-frequency vibration as the suppression frequency. If the value is bigger, it will make more precise judgment. However, if the vibration of the mechanism is smaller, it might not detect the frequency of low-frequency vibration.

P1-31	Reserved	Address: 013EH 013FH
--------------	-----------------	---------------------------------

P1-32	LSTP	Motor Stop Mode	Address: 0140H 0141H
Operational Interface :	Panel / Software	Communication	Related Section: -
Default :	0		
Control Mode :	ALL		
Unit :	-		
Range :	0 ~ 0x20		
Data Size :	16bit		
Format :	HEX		

Settings :

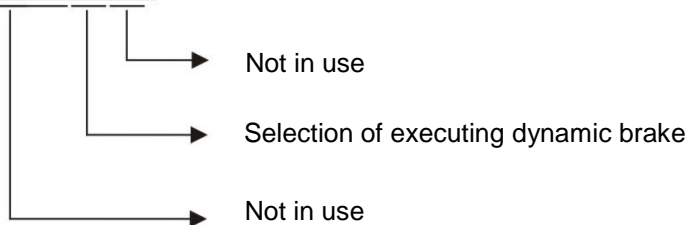

- Selection of executing dynamic brake: Stop Mode when Servo Off or Alarm (including EMGS) occurs.
 - 0: Execute dynamic brake
 - 1: Motor free run
 - 2: Execute dynamic brake first, then execute free run until it stops (The motor speed is slower than P1-38).

When PL and NL occur, please refer to event time setting value of P5-03 for determining the deceleration time. If the setting is 1 ms, it can stop instantaneously.

P1-33	Reserved	Address: 0142H 0143H
--------------	-----------------	---------------------------------

P1-34	TACC	Acceleration Constant of S-Curve		Address: 0144H 0145H
	Operational Interface :	Panel / Software	Communication	
Default :	200			
Control Mode :	S			
Unit :	ms			
Range :	1 ~ 65500			
Data Size :	16bit			
Format :	DEC			

Settings : Acceleration Constant of Rotary Motor:
The time that speed command accelerates from 0 to the rated speed.

Acceleration Constant of Linear Motor
The time that speed command accelerates from 0 to 5m/s.

P1-34, P1-35 and P1-36, the acceleration time of speed command from zero to the rated speed, all can be set individually. Even when P1-36 is set to 0, it still has acceleration / deceleration of trapezoid-curve.

- Note : 1) When the source of speed command is analog, and P1-36 is set to 0, it will disable S-curve function.
- 2)When the source of speed command is analog, the max. range of P1-34 will be set within 20000 automatically.

P1-35	TDEC	Deceleration Constant of S-Curve		Address: 0146H 0147H
	Operational Interface :	Panel / Software	Communication	
Default :	200			
Control Mode :	S			
Unit :	ms			
Range :	1 ~ 65500			
Data Size :	16bit			
Format :	DEC			

Settings : Deceleration Constant of Rotary Motor:

The time that speed command decelerates from the rated speed to 0.

Deceleration Constant of Linear Motor:

The time that speed command decelerates from 5m/s to 0.

P1-34, P1-35 and P1-36, the deceleration time of speed command from the rated speed to zero, all can be set individually. Even when P1-36 is set to 0, it still has acceleration / deceleration of trapezoid-curve.

Note : 1) When the source of speed command is analog, and P1-36 is set to 0, it will disable S-curve function.

2) When the source of speed command is analog, the max. range of P1-35 will be set within 20000 automatically.

P1-36	TSL	Acceleration / Deceleration Constant of S-Curve		Address: 0148H 0149H
	Operational Interface :	Panel / Software	Communication	Related Section: 6.3.3
	Default :	0		
	Control Mode :	S, PR		
	Unit :	ms		
	Range :	0 ~ 65500 (0: disable this function)		
	Data Size :	16bit		
	Format :	DEC		

Settings : Acceleration / Deceleration Constant of S-Curve:
Speed

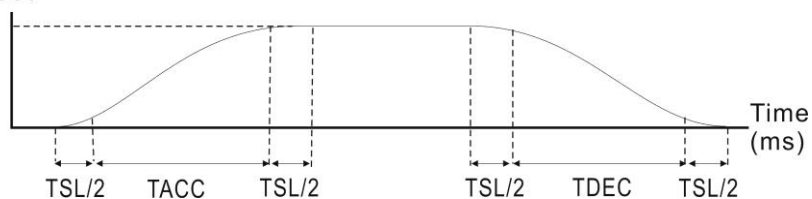

P1-34: Set the acceleration time of acceleration / deceleration of trapezoid-curve

P1-35: Set the deceleration time of acceleration / deceleration of trapezoid-curve

P1-36: Set the smoothing time of S-curve acceleration and deceleration

P1-34, P1-35 and P1-36 can be set individually. Even when P1-36 is set to 0, it still has acceleration / deceleration of trapezoid-curve.

Version after V1.036 sub00 provides the compensation function of following error.

	P1-36 = 0	P1-36 = 1	P1-36 > 1
Smoothing function of S-curve	Disable	Disable	Enable
Compensation function of following error	Disable	Enable	Determine by P2-68.X

- Note : 1) When the source of speed command is analog, and P1-36 is set to 0, it will disable S-curve function.
- 2) When the source of speed command is analog, the max. range of P1-36 will be set within 10000 automatically.

P1-37	GDR	Inertia Ratio or Load Weight Ratio to Servo Motor	Address: 014AH 014BH
Operational Interface :	Panel / Software	Communication	Related Section: -
Default :	1.0	10	
Control Mode :	ALL		
Unit :	Permanent magnet synchronous rotary motor: 1times Permanent magnet synchronous linear motor: 1kg	Permanent magnet synchronous rotary motor: 0.1times Permanent magnet synchronous linear motor: 0.1kg	
Range :	0.0 ~ 1638.3	0 ~ 16383	
Data Size :	16bit		
Format :	One decimal	DEC	
Example :	Permanent magnet synchronous rotary motor: 1.5 = 1.5 times Permanent magnet synchronous linear motor: 1.5 = 1.5kg	Permanent magnet synchronous rotary motor: 15 = 1.5 times Permanent magnet synchronous linear motor: 15 = 1.5kg	

Settings : Inertia ratio to servo motor (rotary motor):
(J_load / J_motor)
Among them:
J_motor: Rotor inertia of the servo motor
J_load : Total equivalent of inertia of external mechanical load.

Total weight of movable section and load (linear motor):
 (M_load+M_motor)
 Among them:
 M_motor: the weight of motor's movable section
 M_load: Total equivalent weight of mechanical loading

P1-38	ZSPD	Zero Speed Range Setting		Address: 014CH 014DH
	Operational Interface :	Panel / Software	Communication	Related Section: Table 8.2
	Default :	10.0	100	
	Control Mode :	ALL		
	Unit :	Permanent magnet synchronous rotary motor: 1rpm Permanent magnet synchronous linear motor: 10 ⁻³ m/s	Permanent magnet synchronous rotary motor: 0.1rpm Permanent magnet synchronous linear motor: 10 ⁻³ m/s	
	Range :	0.0 ~ 200.0	0 ~ 2000	
	Data Size :	16bit		
	Format :	One decimal	DEC	
	Example :	Permanent magnet synchronous rotary motor: 1.5 = 1.5 r/min Permanent magnet synchronous linear motor: 1.5 = 0.015m/s	Permanent magnet synchronous rotary motor: 15 = 1.5 r/min Permanent magnet synchronous linear motor: 15 = 0.015m/s	

Settings : Setting the output range of zero-speed signal (ZSPD). When the forward / reverse speed of the motor is slower than the setting value, the digital output will be enabled.

P1-39	SSPD	Target Motor Detection Level		Address: 014EH 014FH
	Operational Interface :	Panel / Software	Communication	Related Section: Table 8.2
	Default :	3000		
Control Mode :	ALL			

Unit :	Permanent magnet synchronous rotary motor: rpm Permanent magnet synchronous linear motor: 10 ⁻³ m/s
Range :	Permanent magnet synchronous rotary motor: 0 ~ 5000 Permanent magnet synchronous linear motor: 0 ~ 15999
Data Size :	16bit
Format :	DEC

Settings : When the target speed is reached, DO (TSPD) is enabled. It means when the motor speed in forward / reverse direction is higher than the setting value, the target speed is reached and enables DO.

P1-40 ▲	VCM	Maximum Speed of Analog Speed Command	Address: 0150H 0151H
Operational Interface :	Panel / Software	Communication	Related Section: 6.3.4
Default :	Same as the rated speed of each model		
Control Mode :	S / T		
Unit :	Permanent magnet synchronous rotary motor: rpm Permanent magnet synchronous linear motor: 10 ⁻³ m/s		
Range :	Permanent magnet synchronous rotary motor: 0 ~ 5000 Permanent magnet synchronous linear motor: 0 ~ 15999		
Data Size :	16bit		
Format :	DEC		

Settings : Maximum Speed of Analog Speed Command:

In speed mode, the analog speed command inputs the swing speed setting of the max. voltage (10V).

Permanent magnet synchronous rotary motor:

For example, if the setting is 3000, when the external voltage input is 10V, it means the speed control command is 3000r/min. If the external voltage input is 5V, then the speed control command is 1500r/min.

Permanent magnet synchronous linear motor:

If the setting is 3000, when the external voltage input is 10V, it means the speed control command is 3m/s. If the external voltage input is 5V, then the speed control command is 1.5m/s.

Speed control command = input voltage value x setting value / 10

In position or torque (force) mode, analog speed limit inputs the swing speed limit setting of the max. voltage (10V).

Speed limit command = input voltage value x setting value / 10

P1-41 ▲	TCM	Maximum Output of Analog Torque (Force) Speed	Address: 0152H 0153H
Operational Interface :	Panel / Software	Communication	Related Section: 6.4.4
Default :	100		
Control Mode :	ALL		
Unit :	%		
Range :	0 ~ 1000		
Data Size :	16bit		
Format :	DEC		

Settings : Maximum Output of Analog Torque (force) Speed:

In torque (force) mode, the analog torque (force) command inputs the torque (force) setting of the max. voltage (10V). When the default setting is 100, if the external voltage inputs 10V, it means the torque (force) control command is 100% rated torque (force). If the external voltage inputs 5V, then the torque (force) control command is 50% rated torque (force).

Torque (force) control command = input voltage value x setting value / 10 (%)

In speed, PT and PR mode, the analog torque (force) limit inputs the torque (force) limit setting of the max. voltage (10V).

Torque (force) limit command = input voltage value x setting value / 10 (%)

P1-42	MBT1	Enable Delay Time of Brake		Address: 0154H 0155H
	Operational Interface :	Panel / Software	Communication	Related Section: 6.5.5
	Default :	0		
	Control Mode :	ALL		
	Unit :	ms		
	Range :	0 ~ 1000		
	Data Size :	16bit		
	Format :	DEC		

Settings : Set the delay time from servo ON to activate the signal of mechanical brake (BRKR).

P1-43	MBT2	Disable Delay Time of Brake		Address: 0156H 0157H
	Operational Interface :	Panel / Software	Communication	Related Section: 6.5.5
	Default :	0		
	Control Mode :	ALL		
	Unit :	ms		
	Range :	-1000 ~ 1000		
	Data Size :	16bit		
	Format :	DEC		

Settings : Set the delay time from servo OFF to switch off the signal of brake (BRKR).

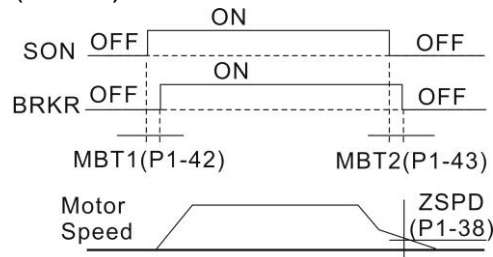

- Note : 1) If the delay time of P1-43 has not finished yet and the motor speed is slower than P1-38, the signal of brake (BRKR) will be disabled.
- 2) If the delay time of P1-43 is up and the motor speed is higher than P1-38, the signal of brake (BRKR) will be disabled.
- 3) When Servo OFF due to Alarm (except AL022) or emergency, the setting of P1-43 is equivalent to 0 if P1-43 is set to a negative value.

P1-44 ▲	GR1	Gear Ratio (Numerator) (N1)	Address: 0158H 0159H
Operational Interface :	Panel / Software	Communication	Related Section: 6.2.5
Default :	1		
Control Mode :	PT / PR		
Unit :	Pulse		
Range :	1 ~ (2 ²⁹ -1)		
Data Size :	32bit		
Format :	DEC		
Settings :	Please refer to P2-60~P2-62 for the setting of multiple gear ratio (numerator).		
Note :	1. In PT mode, the setting value can be changed when Servo ON.		In PR
	2. In PR mode, the setting value can be changed when Servo OFF.		

P1-45	GR2	Gear Ratio (Denominator) (M)	Address: 015AH 015BH
Operational Interface :	Panel / Software	Communication	Related Section: 6.2.5
Default :	1		
Control Mode :	PT / PR		
Unit :	Pulse		
Range :	1 ~ (2 ³¹ -1)		
Data Size :	32bit		
Format :	DEC		

Settings : If the setting is wrong, the servo motor will easily have sudden unintended acceleration.

Please follow the rules for setting:

The setting of pulse input:

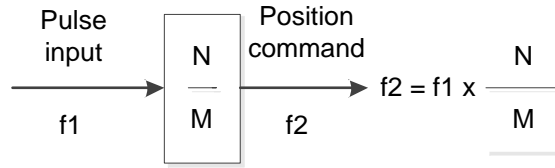

Range of command pulse input: $1 / 50 < N_x / M < 25600$

Note : 1) The setting value cannot be changed when Servo ON neither in PT nor in PR mode.

P1-46 ▲	GR3	Pulse Number of Encoder Output	Address: 015CH 015DH
Operational Interface :	Panel / Software	Communication	Related Section: -
Default :	2500		
Control Mode :	ALL		
Unit :	Pulse		
Range :	20 ~ 536870912		
Data Size :	32bit		
Format :	DEC		

Settings : Permanent magnet synchronous rotary motor:
The number of single-phase pulse output per revolution.
Permanent magnet synchronous linear motor:
The number of single-phase pulse output per meter.

Note : The following circumstances might exceed the max. allowable input pulse frequency and occurs AL018:

1. Abnormal encoder
2. The motor speed is faster than the setting of P1-76.
3. $\frac{\text{Motor Speed}}{60} \times P1-46 \times 4 > 19.8 \times 10^6$

P1-47

SPOK	Speed Reached (DO : SP_OK) Range		Address: 015EH 015FH
Operational Interface :	Panel / Software	Communication	Related Section: -
Default :	10		
Control Mode :	S / Sz		
Unit :	Permanent magnet synchronous rotary motor: rpm Permanent magnet synchronous linear motor: 10^{-3} m/s		
Range :	0 ~ 300		
Data Size :	16bit		
Format :	DEC		

Settings : When the deviation between speed command and motor feedback speed is smaller than this parameter, then the digital output DO.SP_OK (DO code is 0x19) is ON.

Block diagram:

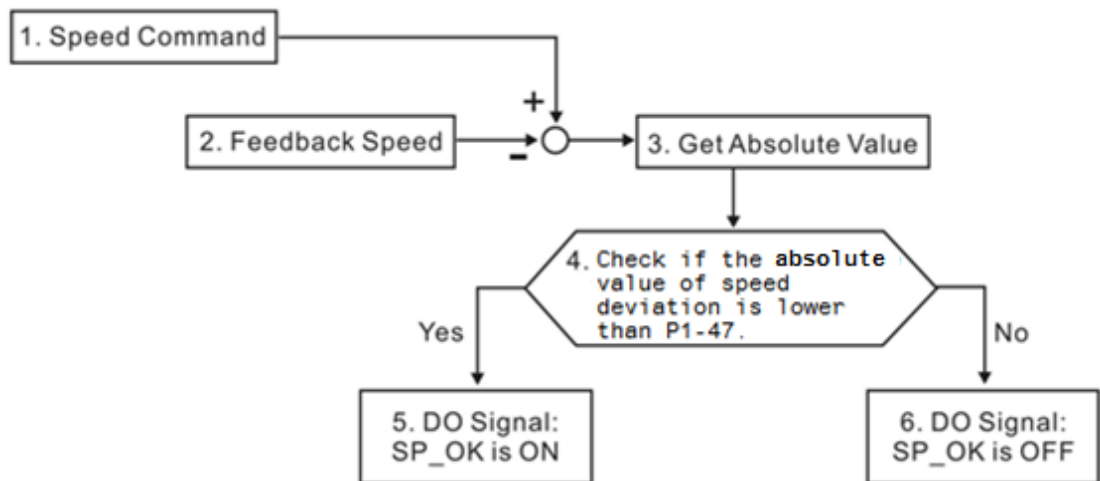

1. Speed command: It is the command issued by the user (without acceleration / deceleration), not the one of front end speed circuit.
Source: Analog voltage and register
2. Feedback speed: The actual speed of the motor and have gone through the filter.
3. Obtain the absolute value.
4. DO.SP_OK will be ON when the absolute value of speed error is smaller than P1-47, or it will be OFF. If P1-47 is 0, DO.SP_OK is always OFF.

P1-48	MCOK	Operation Selection of Motion Reached (DO : MC_OK)		Address: 0160H 0161H
	Operational Interface :	Panel / Software	Communication	Related Section: -
	Default :	0x0000		
	Control Mode :	PR		
	Unit :	-		
	Range :	0x0000 ~ 0x0011		
	Data Size :	16bit		
	Format :	HEX		

Settings : Control selection of digital output DO.MC_OK (DO code is 0x17).
(It will be available after firmware version V1.003 sub08)

The format of this parameter: 00YX

X = 0: It will not remain the digital output status

1: It will remain the digital output status

Y = 0: Alarm, AL380 (position deviation) is not working

1: Alarm, AL380 (position deviation) is working

Block diagram:

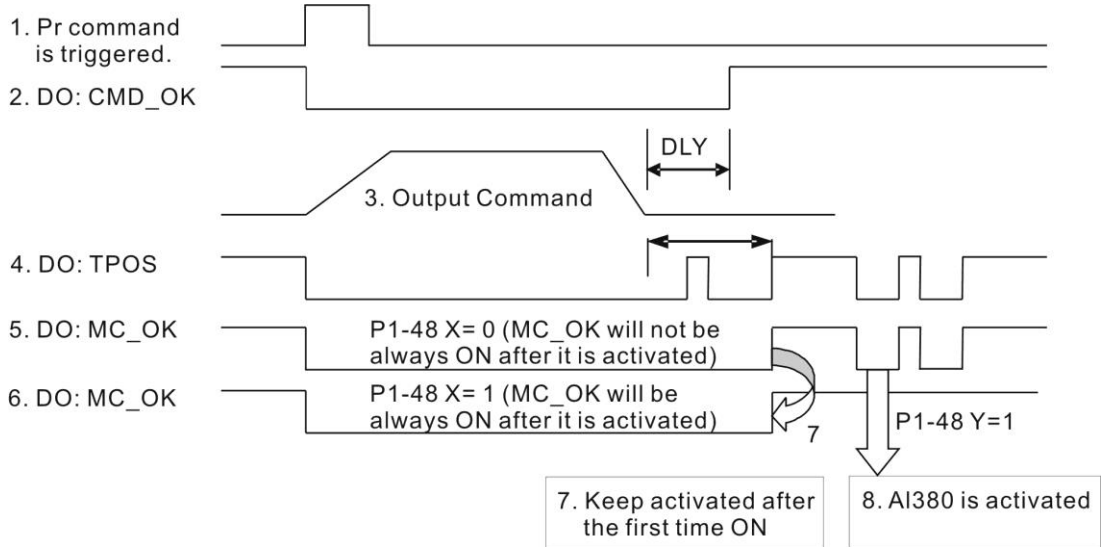

Description:

1. Command triggered: It means the new PR command is effective. Position command starts to output and clear signal 2, 4, 5, 6 at the same time.
2. CMD_OK: It means the position command is completely outputted and can set the delay time (DLY).
3. Command output: Output the profile of position command according to the setting acceleration / deceleration.
4. TPOS: It means the position error of the servo drive is smaller than the value of P1-54.
5. MC_OK: It means the position command is completely outputted and the position error of the servo drive is smaller than P1-54.
6. MC_OK (remains the digital output status): It is the same as 5. However, once this DO is ON, its status will be remained regardless signal 4 is OFF or not.
7. The output profile is determined by parameter P1-48.X.
8. Position Deviation: When number 7 happens, if 4 (or 5) is OFF, it means the position is deviated and AL380 can be triggered.
Set this alarm via parameter P1-48.Y.

P1-49	Reserved		Address: 0162H 0163H
P1-50	Reserved		Address: 0164H 0165H
P1-51	Reserved		Address: 0166H 0167H
P1-52	RES1	Regenerative Resistor Value	Address: 0168H 0169H
	Operational Interface :	Panel / Software Communication	Related Section: 2.7
	Default :	Determined by the model. Please refer to the following table.	
	Control Mode :	ALL	
	Unit :	Ohm	
	Range :	10 ~ 750	
	Data Size :	16bit	
	Format :	DEC	

Settings :

Model	Default
1.5 kW (included) or below	40Ω
2 kW ~ 4.5 kW (included)	20Ω
5.5 kW	15Ω
7.5 kW	15Ω

P1-53	RES2	Regenerative Resistor Capacity	Address: 016AH 016BH
--------------	-------------	---------------------------------------	---------------------------------

Operational Interface :	Panel / Software	Communication	Related Section: 2.7
Default :	Determined by the model. Please refer to the following table.		
Control Mode :	ALL		
Unit :	Watt		
Range :	0 ~ 15000		
Data Size :	16bit		
Format :	DEC		

Settings :

Model	Default
1.5 kW (included) or below	60W
2 kW ~ 4.5 kW (included)	100W
5.5 kW	0W
7.5 kW	0W

P1-54	PER	Position Completed Range	Address: 016CH 016DH
--------------	------------	---------------------------------	---------------------------------

Operational Interface :	Panel / Software	Communication	Related Section: Table 8.2
Default :	12800		
Control Mode :	PT / PR		
Unit :	Pulse		
Range :	0 ~ 1280000		
Data Size :	32bit		
Format :	DEC		

Settings : In position mode (PT), if the deviation pulse number is smaller than the setting range (the setting value of parameter P1-54), DO.TPOS is ON.

In position register (PR) mode, if the deviation between the target position and the actual motor position is smaller than the setting range (the setting value of parameter P1-54), DO.TPOS is ON.

P1-55	MSPD	Maximum Speed Limit		Address: 016EH 016FH
Operational Interface :	Panel / Software	Communication		Related Section: -
Default :	Same as the rated speed of each model			
Control Mode :	ALL			
Unit :	Permanent magnet synchronous rotary motor: rpm Permanent magnet synchronous linear motor: 10 ⁻³ m/s			
Range :	0 ~ max.speed			
Data Size :	16bit			
Format :	DEC			

Settings : The default of the max. speed of servo motor is set to the rated speed.

P1-56	OVW	Output Overload Warning Level		Address: 0170H 0171H
Operational Interface :	Panel / Software	Communication		Related Section: -
Default :	120			
Control Mode :	ALL			
Unit :	%			
Range :	0 ~ 120			
Data Size :	16bit			
Format :	DEC			

Settings : The setting value is 0 ~ 100, if the servo motor continuously outputs the load and is higher than the setting proportion (P1-56), the early warning for overload (DO is set to 10, OLW) will occur. If the setting value is over 100, it will disable this function.

P1-57	CRSHA	Motor Crash Protection (torque percentage)		Address: 0172H 0173H
	Operational Interface :	Panel / Software	Communication	Related Section: -
	Default :	0		
	Control Mode :	ALL		
	Unit :	%		
	Range :	0 ~ 300		
	Data Size :	16bit		
	Format :	DEC		

Settings : Setup protection level (for the percentage of rated torque, set the value to 0 means to disable the function, set the value to 1 or number above means to enable the function)

P1-58	CRSHT	Motor Crash Protection Time		Address: 0174H 0175H
	Operational Interface :	Panel / Software	Communication	Related Section: -
	Default :	1		
	Control Mode :	ALL		
	Unit :	ms		
	Range :	0 ~ 1000		
	Data Size :	16bit		
	Format :	DEC		

Settings : Setup the protection time:
When it reaches the level, AL030 occurs after exceeding the protection time.

Note : This function is only suitable for non-contactable application, such as electric discharge machines. (please setup P1-37 correctly).

P1-59	MFLT	Analog Speed Command		Address: 0176H 0177H
	Operational Interface :	Panel / Software	Communication	Related Section: -
	Default :	0.0	0	
Control Mode :	S			

Unit :	1 ms	0.1 ms
Range :	0.0 ~ 4.0	0 ~ 40
Data Size :	16bit	
Format :	One decimal	DEC
Example :	1.5 = 1.5 ms	15 = 1.5 ms

Settings : (Moving Filter)

0: Disabled

P1-06 is low-pass filter and P1-59 is moving filter. The difference between both is that moving filter can smooth the command in the beginning and end of the step command; while the low-pass filter brings better smooth effect to command end.

Therefore, it is suggested that if the speed loop receives the command from the controller for forming the position control loop, then low-pass filter can be used. If it is only for the speed control, then it should use Moving Filter for better smoothing.

Original step analog speed command

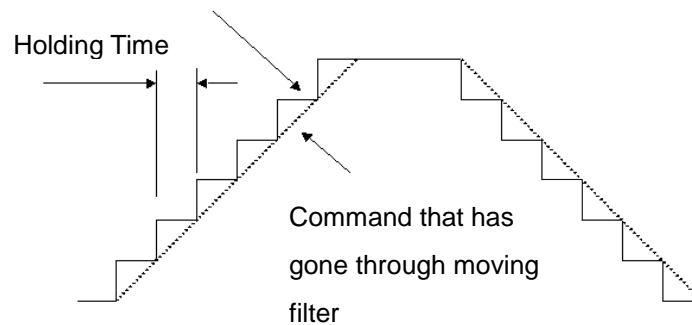

P1-60	Reserved	Address: 0178H 0179H
--------------	-----------------	---------------------------------

P1-61	Reserved	Address: 017AH 017BH
--------------	-----------------	---------------------------------

P1-62	FRCL	Friction Compensation	Address: 017CH 017DH	
	Operational Interface :	Panel / Software		Communication
	Default :	0		
	Control Mode :	PT / PR / S		
	Unit :	%		
	Range :	0 ~ 100		
	Data Size :	16bit		
	Related Section: -			

Format :	DEC
----------	-----

Settings : The level of friction compensation (the percentage of rated torque. Set the value to 0 means to disable the function; set the value to 1 or number above means to enable it.)

P1-63	FRCT	Friction Comenpsation		Address: 017EH 017FH
	Operational Interface :	Panel / Software	Communication	Related Section: -
	Default :	0		
	Control Mode :	PT / PR / S		
	Unit :	ms		
	Range :	0 ~ 1000		
	Data Size :	16bit		
	Format :	DEC		

Settings : Setup smoothing constant of friction compensation.

P1-64	Reserved	Address: 0180H 0181H
--------------	-----------------	---------------------------------

P1-65	Reserved	Address: 0182H 0183H
--------------	-----------------	---------------------------------

P1-66	PCM	Max. Rotation Number of Analog Position Command		Address: 0184H 0185H
	Operational Interface :	Panel / Software	Communication	Related Section: -
	Default :	1.0	10	
	Control Mode :	PT		
	Unit :	1 cycle	0.1 cycle	
	Range :	0.0 ~ 200.0	0 ~ 2000	
	Data Size :	16bit		
	Format :	One decimal	DEC	
	Example :	1.5 = 1.5 cycles	15 =1.5 cycles	

Settings : It is the rotation number setting when analog speed command inputs the max. voltage (10V). If it is set to 30 through the panel and the external voltage inputs 10V, it means the position command is +3 cycles. 5V means the speed control command is 1.5 cycles.

-10V means the position command is -3 cycles.

Position control command = Input voltage value x Setting value / 10

Note : It will be available after firmware version v1.031 sub8.

P1-67	Reserved	Address: 0186H 0187H
--------------	-----------------	---------------------------------

P1-68	PFLT2	Position Command Moving Filter	Address: 0188H 0189H
Operational Interface :	Panel / Software	Communication	Related Section: -
Default :	4		
Control Mode :	PT / PR		
Unit :	ms		
Range :	0 ~ 100		
Data Size :	16bit		
Format :	DEC		

Settings : 0: Disabled

Moving Filter can activate smooth function in the beginning and the end of step command, but it will delay the command.

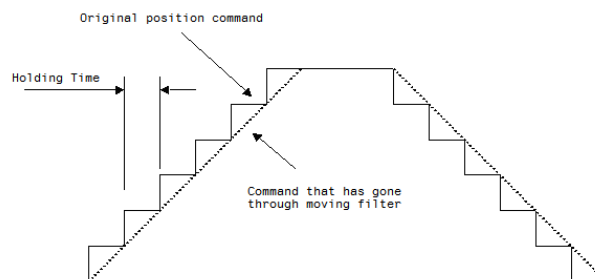

P1-69	Reserved	Address: 018AH 018BH
--------------	-----------------	---------------------------------

P1-70	Reserved	Address: 018CH 018DH
--------------	-----------------	---------------------------------

P1-71	Reserved	Address: 018EH 018FH
--------------	-----------------	---------------------------------

P1-72	FRES	Resolution of Linear Scale for Full-closed Loop Control		Address: 0190H 0191H
	Operational Interface :	Panel / Software	Communication	Related Section: -
	Default :	5000		
	Control Mode :	PT / PR		
	Unit :	pulse / rev		
	Range :	200 ~1280000		
	Data Size :	32bit		
	Format :	DEC		

Settings : A/B pulse corresponded by full-closed loop when motor runs a cycle (after quadruple frequency)

P1-73	FERR	Error Protection Range for Full-closed Loop Control		Address: 0192H 0193H
	Operational Interface :	Panel / Software	Communication	Related Section: P2-34
	Default :	30000		
	Control Mode :	PT / PR		
	Unit :	Pulse (based on the feedback of full-closed loop)		
	Range :	1 ~ (2 ³¹ -1)		
	Data Size :	32bit		
	Format :	DEC		

Settings : The protection is for excessive deviation between feedback position of linear scale and the encoder. When the deviation is excessive, it might result from the loose of connector or other mechanism problems.

P1-74▲	FCON	Full-closed Loop Control of Linear Scale		Address: 0194H 0195H
	Operational Interface :	Panel / Software	Communication	Related Section: P1-46
	Default :	1000h		
	Control Mode :	PT / PR		
	Unit :	-		
Range :	0000h ~ 0x6111			

Data Size :	16bit
Format :	HEX

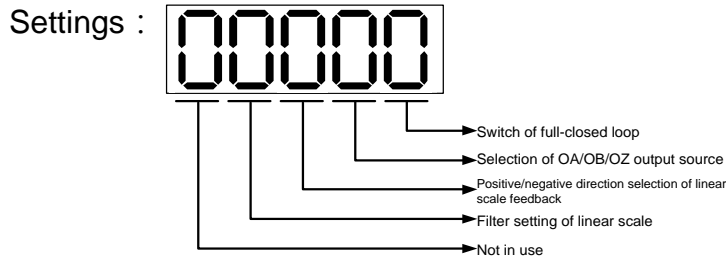

- Settings :
- Switch of full-closed loop control
 - 0: Function of full-closed loop is not used
 - 1: Function of full-closed loop is used
 - 2: Use the function of synchronous control

 - Selection of OA/OB/OZ output source
 - 0: Motor encoder is the output source
 - 1: Encoder of linear scale is the output source
Firmware version DSP V1.016 + CPLD 0.07(or the later version) will provide:
 - 2: Pulse command of CN1 is the output source

 - Positive / negative direction selection of linear scale feedback:
 - 0: It is in positive direction when A phase leads B phase of linear scale
 - 1: It is in negative direction when B phase leads A phase of linear scale

 - Filter setting of linear scale
 - 0: BYPASS
 - 1: 20Mhz
 - 2: 10Mhz
 - 3: 6.66Mhz
 - 4: 1.66Mhz
 - 5: 833K
 - 6: 416K

Take 20Mhz(50ns) as the example:

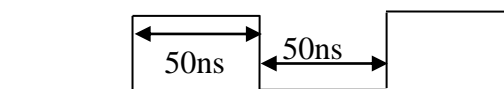

If the width of single-phase pulse is smaller than 50ns, the signal will be filtered.

P1-75	FELP	Low-pass Filter Time Constant of Full-closed Loop control	Address: 0196H 0197H
Operational Interface :	Panel / Software	Communication	Related Section: -
Default :	100		
Control Mode :	PT / PR		
Unit :	ms		
Range :	0 ~ 1000		
Data Size :	16bit		
Format :	DEC		
Settings :	<p>When the stiffness of mechanical system between full- and half-closed loop is insufficient, users can setup the appropriate time constant to enhance the stability of the system.</p> <p>Set the value to 0 to disable the function of low-pass filter (Bypass)</p> <p>The stiffness of mechanical system ↑, the setting value of P1-75 ↓</p> <p>The stiffness of mechanical system ↓, the setting value of P1-75 ↑</p>		

P1-76	AMSPD	Maximum Rotation of Encoder Output Setting (OA, OB)	Address: 0198H 0199H
Operational Interface :	Panel / Software	Communication	Related Section: P1-46
Default :	5500		
Control Mode :	ALL		
Unit :	Permenant magnet synchronous rotary motor: rpm Permenant magnet synchronous linear motor: 10 ⁻³ m/s		
Range :	Permenant magnet synchronous rotary motor: 0 ~ 6000 Permenant magnet synchronous linear motor: 0 ~ 15999		
Data Size :	16bit		
Format :	DEC		
Settings :	<p>According to the real application, this parameter is set for the maximum speed and the servo drive will generate smooth function automatically for encoder output signals.</p> <p>When the value is set to 0, the function is disabled.</p>		

P1-77	Reserved	Address: 019AH 019BH
--------------	----------	-------------------------

P1-78	Reserved	Address: 019CH 019DH
--------------	----------	-------------------------

P1-79	Reserved	Address: 019EH 019FH
--------------	----------	-------------------------

P1-80	Reserved	Address: 01A0H 01A1H
--------------	----------	-------------------------

P1-81	VCM2	Max. Speed of 2nd Analog Speed Command	Address: 01A2H 01A3H
	Operational Interface :	Panel / Software	Communication
	Default :	Motor rated speed	
	Control Mode :	S/T	
	Unit :	rpm/10V	
	Range :	0 ~ 50000	
	Data Size :	32bit	
	Format :	DEC	

Related Section:
P1-40

Settings : Please refer to the description of P1-40.

P1-82	VCMLPF	Filter Switching Time between P1-40 and P1-81	Address: 01A4H 01A5H
	Operational Interface :	Panel / Software	Communication
	Default :	0	
	Control Mode :	S	
	Unit :	msec	
	Range :	0 ~ 1000 (0: disable this function)	
	Data Size :	16bit	
	Format :	DEC	

Related Section:

Settings : 0: Disabled

P2-xx Extension Parameters

P2-00	KPP	Position Loop Gain	Address: 0200H 0201H
	Operational Interface :	Panel / Software Communication	Related Section: 6.2.8
	Default :	35	
	Control Mode :	PT / PR	
	Unit :	rad/s	
	Range :	0 ~ 2047	
	Data Size :	16bit	
	Format :	DEC	
	Settings : When the value of position loop gain is increased, the position response can be enhanced and the position error can be reduced. If the value is set too big, it may easily cause vibration and noise.		

P2-01	PPR	Switching Rate of Position Loop Gain	Address: 0202H 0203H
	Operational Interface :	Panel / Software Communication	Related Section: 6.2.8
	Default :	100	
	Control Mode :	PT / PR	
	Unit :	%	
	Range :	10 ~ 500	
	Data Size :	16bit	
	Format :	DEC	
	Settings : Switch the changing rate of position loop gain according to the gain-switching condition.		

P2-02	PFG	Position Feed Forward Gain	Address: 0204H 0205H
	Operational Interface :	Panel / Software Communication	Related Section: 6.2.8
	Default :	50	
	Control Mode :	PT / PR	
	Unit :	%	

Range :	0 ~ 100
Data Size :	16bit
Format :	DEC

Settings : If the position command is changed smoothly, increasing the gain value can reduce the position error.
If the position command is not changed smoothly, decreasing the gain value can tackle the problem of mechanical vibration.

P2-03	PFF	Smooth Constant of Position Feed Forward Gain		Address: 0206H 0207H
	Operational Interface :	Panel / Software	Communication	Related Section: -
	Default :	5		
	Control Mode :	PT / PR		
	Unit :	ms		
	Range :	2 ~ 100		
	Data Size :	16bit		
	Format :	DEC		

Settings : If the position command is changed smoothly, decreasing the value can reduce the position error. If the position command is not changed smoothly, increasing the value can tackle the problem of mechanical vibration.

P2-04	KVP	Speed Loop Gain		Address: 0208H 0209H
	Operational Interface :	Panel / Software	Communication	Related Section: 6.3.6
	Default :	500		
	Control Mode :	ALL		
	Unit :	rad/s		
	Range :	0 ~ 8191		
	Data Size :	16bit		
	Format :	DEC		

Settings : Increase the value of speed loop gain can enhance the speed response. However, if the value is set too big, it would easily cause resonance and noise.

P2-05	SPR	Switching Rate of Speed Loop Gain		Address: 020AH 020BH
	Operational Interface :	Panel / Software	Communication	Related Section: -
	Default :	100		
	Control Mode :	ALL		
	Unit :	%		
	Range :	10 ~ 500		
	Data Size :	16bit		
	Format :	DEC		

Settings : Switch the changing rate of speed loop gain according to the gain switching condition.

P2-06	KVI	Speed Integral Compensation		Address: 020CH 020DH
	Operational Interface :	Panel / Software	Communication	Related Section: 6.3.6
	Default :	100		
	Control Mode :	ALL		
	Unit :	rad/s		
	Range :	0 ~ 1023		
	Data Size :	16bit		
	Format :	DEC		

Settings : Increasing the value of speed integral compensation can enhance speed response and diminish the deviation of speed control. However, if the value is set too big, it would easily cause resonance and noise.

P2-07	KVF	Speed Feed Forward Gain		Address: 020EH 020FH
	Operational Interface :	Panel / Software	Communication	Related Section: 6.3.6
	Default :	0		
	Control Mode :	ALL		
	Unit :	%		
	Range :	0 ~ 100		

Data Size :	16bit
Format :	DEC

Settings : When the speed control command runs smoothly, increasing the gain value can reduce the speed command error. If the command does not run smoothly, decreasing the gain value can reduce the mechanical vibration during operation.

P2-08	PCTL	Special Parameter Write-in	Address: 0210H 0211H
--------------	-------------	-----------------------------------	---------------------------------

Operational Interface :	Panel / Software	Communication	Related Section: -
Default :	0		
Control Mode :	ALL		
Unit :	-		
Range :	0 ~ 65535		
Data Size :	16bit		
Format :	DEC		

Settings : Special parameter write-in:

Parameter code	Function
10	Reset the parameter (Apply to the power again after reset)
20	P4-10 is writable
22	P4-11~P4-19 are writable
30,35	Save the data of COMPARE, CAPTURE, E-Cam
406	Enable forced DO mode
400	When forced DO mode is enabled, it can switch back to the normal DO mode.

P2-09	DRT	DI Debouncing Time	Address: 0212H 0213H
--------------	------------	---------------------------	---------------------------------

Operational Interface :	Panel / Software	Communication	Related Section: -
Default :	2		
Control Mode :	ALL		
Unit :	2ms		
Range :	0 ~ 20		

Data Size :	16bit
Format :	DEC
Example :	4 = 8 ms

Settings : When the environmental noise is big, increasing the setting value can enhance the control stability. However, if the value is set too big, the response time will be influenced.

P2-10	DI1	DI1 Functional Planning	Address: 0214H 0215H
--------------	------------	--------------------------------	---------------------------------

Operational Interface :	Panel / Software	Communication	Related Section: Table 8.1
Default :	101		
Control Mode :	ALL		
Unit :	-		
Range :	0 ~ 0x015F (the last two codes are DI code)		
Data Size :	16bit		
Format :	HEX		

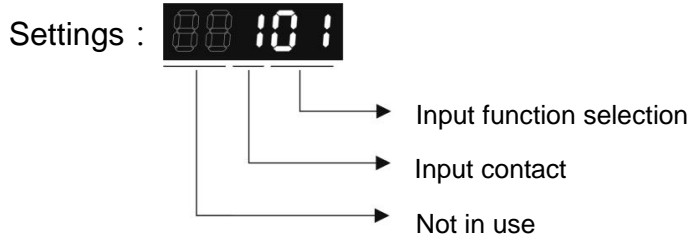

- Input function selection: Please refer to table 8.1
 - Input contact: **a** or **b** contact
 - 0: Set the input contact as normally closed (**b** contact)
 - 1: Set the input contact as normally opened (**a** contact)
- (P2-10 ~ P2-17) The setting value of function programmed

When parameters are modified, please re-start the servo drive to ensure it can work normally.

Note: Parameter P3-06 is used to set how digital inputs (DI) accepts commands, through external terminal or the communication which determined by P4-07.

P2-11	DI2	DI2 Functional Planning	Address: 0216H 0217H
--------------	------------	--------------------------------	---------------------------------

Operational Interface :	Panel / Software	Communication	Related Section: Table 8.1
Default :	104		

Control Mode :	ALL
Unit :	-
Range :	0 ~ 0x015F (the last two codes are DI code)
Data Size :	16bit
Format :	HEX

Settings : Please refer to the description of P2-10

P2-12	DI3	DI3 Functional Planning		Address: 0218H 0219H
	Operational Interface :	Panel / Software	Communication	Related Section: Table 8.1
	Default :	116		
	Control Mode :	ALL		
	Unit :	-		
	Range :	0 ~ 0x015F (the last two codes are DI code)		
	Data Size :	16bit		
	Format :	HEX		

Settings : Please refer to the description of P2-10

P2-13	DI4	DI4 Functional Planning		Address: 021AH 021BH
	Operational Interface :	Panel / Software	Communication	Related Section: Table 8.1
	Default :	117		
	Control Mode :	ALL		
	Unit :	-		
	Range :	0 ~ 0x015F (the last two codes are DI code)		
	Data Size :	16bit		
	Format :	HEX		

Settings : Please refer to the description of P2-10

P2-14	DI5	DI5 Functional Planning		Address: 021CH 021DH
Operational Interface :	Panel / Software	Communication	Related Section: Table 8.1	
Default :	102			
Control Mode :	ALL			
Unit :	-			
Range :	0 ~ 0x015F (the last two codes are DI code)			
Data Size :	16bit			
Format :	HEX			

Settings : Please refer to the description of P2-10

P2-15	DI6	DI6 Functional Planning		Address: 021EH 021FH
Operational Interface :	Panel / Software	Communication	Related Section: Table 8.1	
Default :	22			
Control Mode :	ALL			
Unit :	-			
Range :	0 ~ 0x015F (the last two codes are DI code)			
Data Size :	16bit			
Format :	HEX			

Settings : Please refer to the description of P2-10

P2-16	DI7	DI7 Functional Planning		Address: 0220H 0221H
Operational Interface :	Panel / Software	Communication	Related Section: Table 8.1	
Default :	23			
Control Mode :	ALL			
Unit :	-			
Range :	0 ~ 0x015F (the last two codes are DI code)			
Data Size :	16bit			

Format :	HEX
----------	-----

Settings : Please refer to the description of P2-10

P2-17	DI8	DI8 Functional Planning	Address: 0222H 0223H
	Operational Interface :	Panel / Software Communication	Related Section: Table 8.1
	Default :	21	
	Control Mode :	ALL	
	Unit :	-	
	Range :	0 ~ 0x015F (the last two codes are DI code)	
	Data Size :	16bit	
	Format :	HEX	

Settings : Please refer to the description of P2-10

P2-18	DO1	DO1 Functional Planning	Address: 0224H 0225H
	Operational Interface :	Panel / Software Communication	Related Section: Table 8.2
	Default :	101	
	Control Mode :	ALL	
	Unit :	-	
	Range :	0 ~ 0x013F (the last two codes are DO code)	
	Data Size :	16bit	
	Format :	HEX	

Settings : 

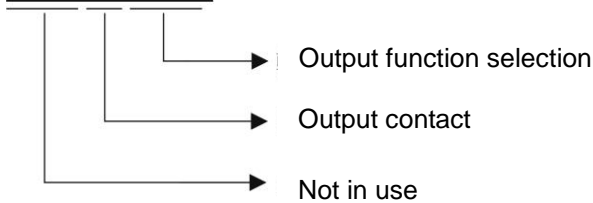

- Output function selection: Please refer to table 8.2
 - Output contact: **a** or **b** contact
 - 0: Set the output contact as normally closed (**b** contact)
 - 1: Set the output contact as normally opened (**a** contact)
- (P2-18 ~ P2-22) The setting value of function programmed
 When parameters are modified, please re-start the servo drive to ensure it can work normally.

P2-19	DO2	DO2 Functional Planning		Address: 0226H 0227H
	Operational Interface :	Panel / Software	Communication	Related Section: Table 8.2
	Default :	103		
	Control Mode :	ALL		
	Unit :	-		
	Range :	0 ~ 0x013F (the last two codes are DO code)		
	Data Size :	16bit		
	Format :	HEX		

Settings : Please refer to the description of P2-18

P2-20	DO3	DO3 Functional Planning		Address: 0228H 0229H
	Operational Interface :	Panel / Software	Communication	Related Section: Table 8.2
	Default :	109		
	Control Mode :	ALL		
	Unit :	-		
	Range :	0 ~ 0x013F (the last two codes are DO code)		
	Data Size :	16bit		
	Format :	HEX		

Settings : Please refer to the description of P2-18

P2-21	DO4	DO4 Functional Planning		Address: 022AH 022BH
	Operational Interface :	Panel / Software	Communication	Related Section: Table 8.2
	Default :	105		
	Control Mode :	ALL		
	Unit :	-		
	Range :	0 ~ 0x013F (the last two codes are DO code)		
	Data Size :	16bit		
	Format :	HEX		
Settings : Please refer to the description of P2-18				

P2-22	DO5	DO5 Functional Planning		Address: 022CH 022DH
	Operational Interface :	Panel / Software	Communication	Related Section: Table 8.2
	Default :	7		
	Control Mode :	ALL		
	Unit :	-		
	Range :	0 ~ 0x013F (the last two codes are DO code)		
	Data Size :	16bit		
	Format :	HEX		
Settings : Please refer to the description of P2-18				

P2-23	NCF1	Resonance Suppression (Notch filter) (1)		Address: 022EH 022FH
	Operational Interface :	Panel / Software	Communication	Related Section: 6.3.7
	Default :	1000		
	Control Mode :	ALL		
	Unit :	Hz		
	Range :	50 ~ 1000		
	Data Size :	16bit		

Format :	DEC
----------	-----

Settings : The first setting value of resonance frequency. If P2-24 is set to 0, this function is disabled. P2-43 and P2-44 are the second Notch filter.

P2-24	DPH1	Resonance Suppression (Notch filter) Attenuation Rate (1)		Address: 0230H 0231H
	Operational Interface :	Panel / Software	Communication	Related Section: 6.3.7
	Default :	0		
	Control Mode :	ALL		
	Unit :	dB		
	Range :	0 ~ 32 (0: disable the function of Notch filter)		
	Data Size :	16bit		
	Format :	DEC		

Settings : The first resonance suppression (notch filter) attenuation rate. When this parameter is set to 0, the function of Notch filter is disabled.

P2-25	NLP	Low-pass Filter of Resonance Suppression		Address: 0232H 0233H
	Operational Interface :	Panel / Software	Communication	Related Section: 6.3.7
	Default :	0.2 (under 1kW) or 0.5 (other model)	2 (under 1kW) or 0.5 (other model)	
	Control Mode :	ALL		
	Unit :	1 ms	0.1 ms	
	Range :	0.0 ~ 100.0	0 ~ 1000	
	Data Size :	16bit		
	Format :	One decimal	DEC	
Example :	1.5 = 1.5 ms	15 = 1.5 ms		

Settings : Set the low-pass filter of resonance suppression. When the value is set to 0, the function of low-pass filter is disabled.

P2-26	DST	Anti-interference Gain	Address: 0234H 0235H
Operational Interface :	Panel / Software	Communication	Related Section: -
Default :	0		
Control Mode :	ALL		
Unit :	1		
Range :	0 ~ 1023 (0: disable this function)		
Data Size :	16bit		
Format :	DEC		

Settings : Increasing the value of this parameter can increase the damping of speed loop. It is suggested to set P2-26 equals to the value of P2-06. If users desire to adjust P2-26, please follow the rules below.

1. In speed mode, increase the value of this parameter can reduce speed overshoot.
2. In position mode, decrease the value of this parameter can reduce position overshoot.

P2-27	GCC	Gain Switching and Switching Selection	Address: 0236H 0237H
Operational Interface :	Panel / Software	Communication	Related Section: -
Default :	0		
Control Mode :	ALL		
Unit :	-		
Range :	0 ~ 0x4		
Data Size :	16bit		
Format :	HEX		

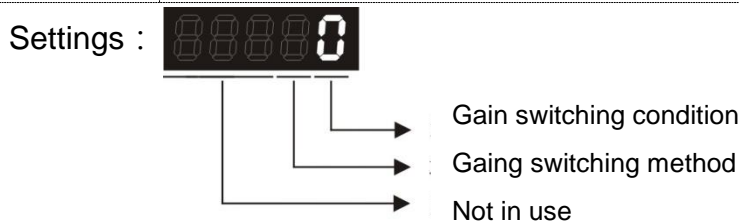

- Gain switching condition:
 - 0: Disable gain switching function.
 - 1: The signal of gain switching (GAINUP) is ON.
 - 2: In position control mode, the position error is bigger than the value of P2-29.
 - 3: The frequency of position command is bigger than the value of P2-29.
 - 4: When the speed of servo motor is faster than the value of P2-29.
 - 5: The signal of gain switching (GAINUP) is OFF.
 - 6: In position control mode, the position error is smaller than the value of P2-29.
 - 7: When the frequency of position command is smaller than the value of P2-29.
 - 8: When the speed of servo motor is slower than the value of P2-29.
- Gain switching method:
 - 0: Gain switching
 - 1: Integrator switching, P -> PI

Setting Value	Control Mode P	Control Mode S	
0	P2-00 x 100% P2-04 x 100%	P2-04 x 100%	Before switching
	P2-00 x P2-01 P2-04 x P2-05	P2-04 x P2-05	After switching
1	P2-06 x 0% P2-26 x 0%		Before switching
	P2-06 x 100% P2-26 x 100%		After switching

P2-28	GUT	Gain Switching Time Constant	Address: 0238H 0239H
Operational Interface :	Panel / Software	Communication	Related Section: -
Default :	10		
Control Mode :	ALL		
Unit :	10ms		
Range :	0 ~ 1000		
Data Size :	16bit		
Format :	DEC		
Example :	15 = 150 ms		

Settings : It is for switching the smooth gain. (0: disable this function)

P2-29	GPE	Gain Switching		Address: 023AH 023BH
	Operational Interface :	Panel / Software	Communication	
Default :	1280000			
Control Mode :	ALL			
Unit :	Pulse, Kpps, r/min			
Range :	0 ~ 3840000			
Data Size :	32bit			
Format :	DEC			

Settings : The setting of gain switching (Pulse error, Kpps, r/min) is determined by the selection of gain switching (P2-27).

P2-30	INH	Auxiliary Function		Address: 023CH 023DH
	Operational Interface :	Panel / Software	Communication	
Default :	0			
Control Mode :	ALL			
Unit :	-			
Range :	-8 ~ +8			
Data Size :	16bit			
Format :	DEC			

- Settings :
- 0: Disable all functions described below
 - 1: Force to Servo On the software
 - 2~4: (reserved)
 - 5: This setting allows the written parameters not retain after power off. When the data is no need to save, it can avoid the parameters continuously writing into EEPROM and shortening the lifetime of EEPROM.
Setting this parameter is a must when using communication control.
 - 6: In simulation mode (command simulation), the external Servo On signal cannot work and DSP Error (variable 0x6F) is regarded as 0. Parameter P0-01 only shows the external Error (positive/negative limit, emergency stop, etc)
In this status, DO.SRDY is ON. Command is accepted in each mode and can be observed via scope software. However, the motor will not operate. The aim is to examine the command accuracy.
 - 7: (It will be available after firmware version V1.013)
High-speed oscilloscope, disable Time-Out function (It is for PC software)
 - 8: (It will be available after firmware version V1.013)
Back up all parameters (current value) and save in EEPROM.
The value still exists when re-power on.
The panel displays 'to.rom' during execution. (It can be executed when Servo ON.)
 - 1,-5,-6,-7: (It will be available after firmware version V1.013)
Individually disable the function of 1,5,6,7
 - 2~-4, -8: (Reserved)

Note : Please set the value to 0 in normal operation. The value returns to 0 automatically after re-power on.

P2-31	AUT1	Speed Loop Frequency Response Setting in Auto and Semi-auto Mode	Address: 023EH 023FH
Operational Interface :	Panel / Software	Communication	Related Section: 5.6 and 6.3.6
Default :	80		
Control Mode :	ALL		
Unit :	Hz		
Range :	1 ~ 0x1000		
Data Size :	16bit		
Format :	HEX		

Settings : 1~50Hz: Low stiffness, low response
 51~250Hz: Medium stiffness, medium response
 251~850Hz: High stiffness, high response
 851~1000Hz: Extremely high stiffness, extremely high response

Note : 1) According to the speed loop setting of P2-31, the servo drive sets the position loop response automatically.
 2) The function is enabled via parameter P2-32. Please refer to Chapter 5.6 for corresponding bandwidth size of the setting value.

P2-32 ▲	AUT2	Tuning Mode Selection		Address: 0240H 0241H
	Operational Interface :	Panel / Software	Communication	Related Section: 5.6 and 6.3.6
	Default :	0		
	Control Mode :	ALL		
	Unit :	-		
	Range :	0 ~ 0x2		
	Data Size :	16bit		
	Format :	HEX		

Settings : 0: Manual Mode
 1: Auto Mode (continuous adjustment)
 2: Semi-auto Mode (non- continuous adjustment)

Relevant description of manual mode setting:

When P2-32 is set to 0, parameters related to gain control, such as P2-00, P2-02, P2-04, P2-06, P2-07, P2-25 and P2-26, all can be set by the user.

When switching mode from auto or semi-auto to manual, parameters about gain will be updated automatically.

Relevant description of auto mode setting:

Continue to estimate the system inertia, save the inertia ratio to P1-37 every 30 minutes automatically and refer to the stiffness and bandwidth setting of P2-31.

1. Set the system to manual mode 0 from auto 1 or semi-auto 2, the system will save the estimated inertia value to P1-37 automatically and set the corresponding parameters.

2. Set the system to auto mode 1 or semi-auto mode 2 from manual mode 0, please set P1-37 to the appropriate value.
3. Set the system to manual mode 0 from auto mode 1, P2-00, P2-04 and P2-06 will be modified to the corresponding parameters of auto mode.
4. Set the system to manual mode 0 from semi-auto mode 2, P2-00, P2-04, P2-06, P2-25 and P2-26 will be modified to the corresponding parameters of semi-auto mode.

Relevant description of semi-auto mode setting:

1. When the system inertia is stable, the value of P2-33 will be 1 and the system stops estimating. The inertia value will be saved to P1-37 automatically. When switching mode to semi-auto mode (from manual or auto mode), the system starts to estimate again.
 2. When the system inertia is over the range, the value of P2-33 will be 0 and the system starts to estimate and adjust again.
- ※ Rotary motor uses inertia ratio for estimation; Linear motor uses weight of linear motor and load for estimation.

P2-33 ▲	AUT3	Semi-auto Inertia Adjustment		Address: 0242H 0243H
Operational Interface :	Panel / Software	Communication		Related Section: -
Default :	0			
Control Mode :	ALL			
Unit :	-			
Range :	0 ~ 1			
Data Size :	16bit			
Format :	DEC			

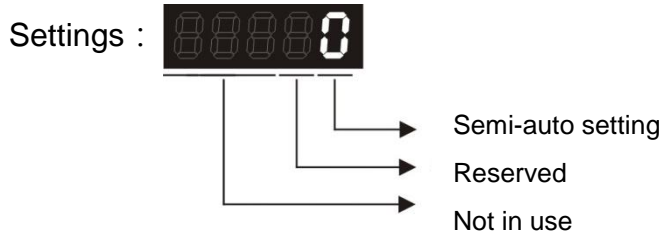

- **Semi-auto Setting:**
 - 1: It means the inertia estimation in semi-auto mode is completed. The inertia value can be accessed via P1-37.
 - 0: 1. When the display is 0, it means the inertia adjustment is not completed and is adjusting.
 2. When the setting is 0, it means the inertia adjustment is not completed and is adjusting.
- ※ Rotary motor uses inertia ratio for estimation; Linear motor uses weight of linear motor and load for estimation.

P2-34	SDEV	The Condition of Overspeed Warning	Address: 0244H 0245H
Operational Interface :	Panel / Software	Communication	Related Section: -
Default :	5000		
Control Mode :	S		
Unit :	Permanent magnet synchronous rotary motor: rpm Permanent magnet synchronous linear motor: 10 ⁻³ m/s		
Range :	Permanent magnet synchronous rotary motor: 1 ~ 5000 Permanent magnet synchronous linear motor: 1~15999		
Data Size :	16bit		
Format :	DEC		

Settings : The setting of over speed warning in servo drive error display (P0-01)

P2-35	PDEV	Condition of Excessive Position Control Deviation Warning	Address: 0246H 0247H
Operational Interface :	Panel / Software	Communication	Related Section: -
Default :	3840000		
Control Mode :	PT / PR		

Unit :	pulse
Range :	1 ~ 128000000
Data Size :	32bit
Format :	DEC

Settings : The setting of excessive position control deviation warning in servo drive error display (P0-01)

P2-36	EDI9	Extended EDI9 Functional Planning	Address: 0248H 0249H
--------------	-------------	--	---------------------------------

Operational Interface :	Panel / Software	Communication	Related Section: Table 8.1
Default :	0		
Control Mode :	ALL		
Unit :	-		
Range :	0 ~ 0x015F (the last two codes are EDI code)		
Data Size :	16bit		
Format :	HEX		

Settings : 

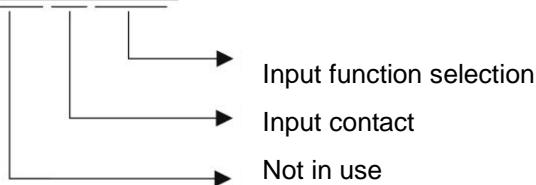

- Input function selection: Please refer to table 8.1
- Input contact: **a** or **b** contact
 - 0: Set the input contact as normally closed (**b** contact)
 - 1: Set the input contact as normally opened (**a** contact)

(P2-36 ~ P2-41) The setting value of function programmed
When parameters are modified, please re-start the servo drive to ensure it can work normally.

P2-37	EDI10	Extended EDI10 Functional Planning	Address: 024AH 024BH
--------------	--------------	---	---------------------------------

Operational Interface :	Panel / Software	Communication	Related Section: Table 8.1
Default :	0		
Control Mode :	ALL		

Unit :	-
Range :	0 ~ 0x015F (the last two codes are EDI code)
Data Size :	16bit
Format :	HEX

Settings : Please refer to the description of P2-36

P2-38	EDI11	Extended EDI11 Functional Planning	Address: 024CH 024DH
	Operational Interface :	Panel / Software	Communication
	Default :	0	
	Control Mode :	ALL	
	Unit :	-	
	Range :	0 ~ 0x015F (the last two codes are EDI code)	
	Data Size :	16bit	
	Format :	HEX	

Related Section:
Table 8.1

Settings : Please refer to the description of P2-36

P2-39	EDI12	Extended EDI12 Functional Planning	Address: 024EH 024FH
	Operational Interface :	Panel / Software	Communication
	Default :	-	
	Control Mode :	ALL	
	Unit :	-	
	Range :	0 ~ 0x015F (the last two codes are EDI code)	
	Data Size :	16bit	
	Format :	HEX	

Related Section
Table: 8.1

Settings : Please refer to the description of P2-36

P2-40	EDI13	Extended EDI13 Functional Planning		Address: 0250H 0251H
	Operational Interface :	Panel / Software	Communication	Related Section: Table 8.1
	Default :	-		
	Control Mode :	ALL		
	Unit :	-		
	Range :	0 ~ 0x015F (the last two codes are EDI code)		
	Data Size :	16bit		
	Format :	HEX		

Settings : Please refer to the description of P2-36

P2-41	EDI14	Extended EDI14 Functional Planning		Address: 0252H 0253H
	Operational Interface :	Panel / Software	Communication	Related Section: Table 8.1
	Default :	-		
	Control Mode :	ALL		
	Unit :	-		
	Range :	0 ~ 0x015F (the last two codes are EDI code)		
	Data Size :	16bit		
	Format :	HEX		

Settings : Please refer to the description of P2-36

P2-42	Reserved	Address: 0254H 0255H
--------------	-----------------	---------------------------------

P2-43	NCF2	Resonance Suppression (Notch filter) (2)		Address: 0256H 0257H
	Operational Interface :	Panel / Software	Communication	Related Section: 6.3.7
	Default :	1000		
	Control Mode :	ALL		
Unit :	Hz			

Range :	50 ~ 2000
Data Size :	16bit
Format :	DEC

Settings : The second setting value of resonance frequency. If P2-44 is set to 0, this function is disabled. P2-23 and P2-24 are the first Notch filter.

P2-44	DPH2	Resonance Suppression (Notch filter) Attenuation Rate (2)	Address: 0258H 0259H
Operational Interface :	Panel / Software	Communication	Related Section: 6.3.7
Default :	0		
Control Mode :	ALL		
Unit :	dB		
Range :	0 ~ 32 (0: disable Notch filter)		
Data Size :	16bit		
Format :	DEC		

Settings : The second resonance suppression (notch filter) attenuation rate. When this parameter is set to 0, the function of Notch filter is disabled.

P2-45	NCF3	Resonance Suppression (Notch filter) (3)	Address: 025AH 025BH
Operational Interface :	Panel / Software	Communication	Related Section: 6.3.7
Default :	1000		
Control Mode :	ALL		
Unit :	Hz		
Range :	50 ~ 2000		
Data Size :	16bit		
Format :	DEC		

Settings : The third group of mechanism resonance frequency setting value. If P2-46 is set to 0, this function will be disabled. P2-23 and P2-24 are the first group of resonance suppression (Notch filter).

P2-46	DPH3	Resonance Suppression (Notch filter) Attenuation Rate (3)		Address: 025CH 025DH
	Operational Interface :	Panel / Software	Communication	Related Section: 6.3.7
	Default :	0		
	Control Mode :	ALL		
	Unit :	dB		
	Range :	0 ~ 32		
	Data Size :	16bit		
	Format :	DEC		

Settings : The third group of resonance suppression (Notch filter) attenuation rate. Set the value to 0 to disable the function of Notch filter.

P2-47	ANCF	Auto Resonance Suppression Mode Setting		Address: 025EH 025FH
	Operational Interface :	Panel / Software	Communication	Related Section: -
	Default :	1		
	Control Mode :	ALL		
	Unit :	-		
	Range :	0 ~ 2		
	Data Size :	16bit		
	Format :	DEC		

Settings :

- 0: The value of P2-43, P2-44 and P2-45, P2-46 will retain.
- 1: The value of P2-43, P2-44 and P2-45, P2-46 will retain after resonance suppression.
- 2: Continuous resonance suppression

Description of Auto Mode Setting:

When it is set to 1: Auto resonance, the value returns to 0 automatically and saves the point of resonance suppression when it is stable. If it is unstable, re-power on or set back to 1 for re-estimation again.

When it is set to 2: Continuous suppression automatically. When it is stable, the point of resonance suppression will be saved. If it is unstable, re-power on for re-estimation.

When switching to mode 0 from mode 2 or 1, the setting of P2-43, P2-44, P2-45 and P2-46 will be saved automatically.

P2-48	ANCL	Resonance Suppression Detection Level		Address: 0260H 0261H
	Operational Interface :	Panel / Software	Communication	Related Section: -
Default :	100			
Control Mode :	ALL			
Unit :	-			
Range :	1 ~ 300%			
Data Size :	16bit			
Format :	DEC			
Settings : (The smaller the setting value is, the more sensitive the resonance will be.)				
P2-48↑, resonance sensitiveness↓				
P2-48↓, resonance sensitiveness↑				

P2-49	SJIT	Speed Detection Filter		Address: 0262H 0263H
	Operational Interface :	Panel / Software	Communication	Related Section: -
Default :	0			
Control Mode :	ALL			
Unit :	-			
Range :	0 ~ 1F			
Data Size :	16bit			
Format :	DEC			

Settings : The filter of speed estimation

Setting Value	Speed Estimation Bandwidth (Hz)
00	2500
01	2250
02	2100
03	2000
04	1800
05	1600
06	1500
07	1400
08	1300
09	1200
0A	1100
0B	1000
0C	950
0D	900
0E	850
0F	800
10	750
11	700
12	650
13	600
14	550
15	500
16	450
17	400
18	350
19	300
1A	250
1B	200
1C	175
1D	150
1E	125
1F	100

P2-50	DCLR	Pulse Clear Mode		Address: 0264H 0265H
	Operational Interface :	Panel / Software	Communication	Related Section: -
	Default :	0		
	Control Mode :	PT / PR		

Unit :	-
Range :	0 ~ 0x2
Data Size :	16bit
Format :	HEX

Settings : Please refer to table 8.1 for digital input setting.

When set digital input (DI) as CCLR, the function of pulse clear is effective. Clear the position error (It is applicable in PT, PR mode). If this DI is ON, the accumulative position error will be cleared to 0.

0: The triggering method of CCLR is rising-edge.

1: The triggering method of CCLR is level.

P2-51	Reserved	Address: 0266H 0267H
--------------	-----------------	---------------------------------

P2-52	Reserved	Address: 0268H 0269H
--------------	-----------------	---------------------------------

P2-53	KPI	Position Integral Compensation	Address: 026AH 026BH
Operational Interface :	Panel / Software	Communication	Related Section: 6.3.6
Default :	0		
Control Mode :	ALL		
Unit :	rad/s		
Range :	0 ~ 1023		
Data Size :	16bit		
Format :	DEC		

Settings : When increasing the value of position control integral, reducing the position steady-state error, it may easily cause position overshoot and noise if the value is set too big.

P2-54	SVP	The Gain of Synchronous Speed Control	Address: 026CH 026DH
Operational Interface :	Panel / Software	Communication	Related Section: -
Default :	0		
Control Mode :	ALL		
Unit :	Rad/s		

Range :	0~8191
Data Size :	16bit
Format :	DEC

Settings : When increasing the value of synchronous speed control, it can enhance the speed following of two motors. However, if the value is set too big, it may easily cause vibration and noise.

P2-55	SVI	Integral Compensation to Synchronous Position	Address: 026EH 026FH
--------------	------------	--	---------------------------------

Operational Interface :	Panel / Software	Communication	Related Section: -
Default :	0		
Control Mode :	ALL		
Unit :	Rad/s		
Range :	0~1023		
Data Size :	16bit		
Format :	DEC		

Settings : When increasing integral compensation to synchronous speed, two motors speed following can be enhanced and the speed error between two motors can be reduced. However, if the value is set too big, it may easily cause vibration and noise.

P2-56	SPI	Integral Compensation to Synchronous Position	Address: 0270H 0271H
--------------	------------	--	---------------------------------

Operational Interface :	Panel / Software	Communication	Related Section: -
Default :	0		
Control Mode :	ALL		
Unit :	Rad		
Range :	0~1023		
Data Size :	16bit		
Format :	DEC		

Settings : When increasing integral compensation to synchronous position, two motors speed following can be enhanced and the speed error between two motors can be reduced. However, if the value is set too big, it may easily cause vibration and noise It is suggested to set the value the same as P2-06.

P2-57	SBW	The Bandwidth of Synchronous Control		Address: 0272H 0273H
	Operational Interface :	Panel / Software	Communication	Related Section: -
	Default :	0		
	Control Mode :	ALL		
	Unit :	Hz		
	Range :	0~1023		
	Data Size :	16bit		
	Format :	DEC		
	Settings :	If users do not know how to set P2-54~P2-56, setting the bandwidth of synchronous control value will do since the value will correspond to P2-54~P2-56. The bigger the bandwidth of synchronous control value is, the better the synchronous effect will be. When increasing the bandwidth of speed loop and synchronous control, pay special attention to the response of P2-25 which should be faster than the setting of the both bandwidth.		

P2-58	SVL	Low-pass Filter of Synchronous Speed Error		Address: 0274H 0275H
	Operational Interface :	Panel / Software	Communication	Related Section: -
	Default :	0		
	Control Mode :	ALL		
	Unit :	0.1ms		
	Range :	0~1000		
	Data Size :	16bit		
	Format :	DEC		
	Example :	15 = 1.5 ms		
Settings :	If the synchronous control is influenced by low resolution and causes noise (not a high-pitched but rough sound), low-pass filter can be used to solve this problem. Please note that bandwidth of the synchronous control should be set as large as possible and should larger than the bandwidth of speed-loop.			

P2-59	Reserved	Address: 0276H 0277H
--------------	-----------------	---------------------------------

P2-60	GR4	Gear Ratio (Numerator) (N2)		Address: 0278H 0279H
	Operational Interface :	Panel / Software	Communication	Related Section: -
	Default :	128		
	Control Mode :	PT		
	Unit :	pulse		
	Range :	1 ~ (2 ²⁹ -1)		
	Data Size :	32bit		
	Format :	DEC		

Settings : The numerator of electronic gear ratio can be selected via DI.GNUM0 and DI.GNUM1 (Please refer to table 8.1). If DI.GNUM0 and DI.GNUM1 are not set, P1-44 will automatically be the numerator of electronic gear ratio. Please switch GNUM0 and GNUM1 in stop status to avoid the mechanical vibration.

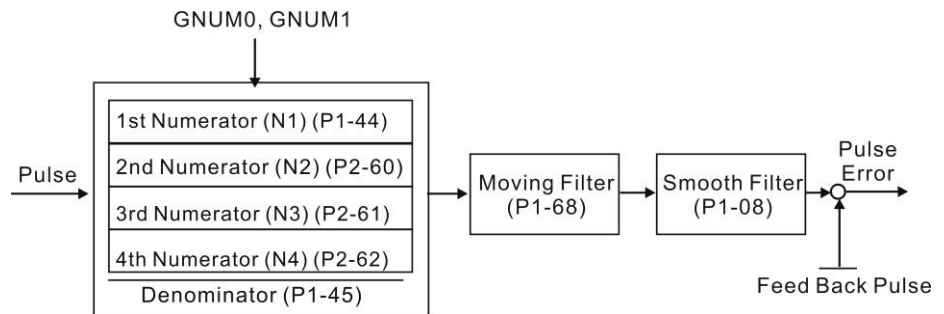

P2-61	GR5	Gear Ratio (Numerator) (N3)		Address: 027AH 027BH
	Operational Interface :	Panel / Software	Communication	Related Section: -
	Default :	128		
	Control Mode :	PT		
	Unit :	pulse		
	Range :	1 ~ (2 ²⁹ -1)		
	Data Size :	32bit		
	Format :	DEC		

Settings : Please refer to the description of P2-60.

P2-62	GR6	Gear Ratio (Numerator) (N4)		Address: 027CH 027DH
	Operational Interface :	Panel / Software	Communication	Related Section: -
	Default :	128		
	Control Mode :	PT		
	Unit :	pulse		
	Range :	1 ~ (2 ²⁹ -1)		
	Data Size :	32bit		
	Format :	DEC		

Settings : Please refer to the description of P2-60.

P2-63	Reserved	Address: 027EH 027FH
-------	----------	-------------------------

P2-64	Reserved	Address: 0280H 0281H
-------	----------	-------------------------

P2-65	GBIT	Special-bit Register		Address: 0282H 0283H
	Operational Interface :	Panel / Software	Communication	Related Section: -
	Default :	0		
	Control Mode :	PT / PR / S		
	Unit :	-		
	Range :	0 ~ 0xFFFF		
	Data Size :	-		
	Format :	-		

Settings :

Bit7	Bit6	Bit5	Bit4	Bit3	Bit2	Bit1	Bit0
------	------	------	------	------	------	------	------

Bit15	Bit14	Bit13	Bit12	Bit11	Bit10	Bit9	Bit8
-------	-------	-------	-------	-------	-------	------	------

- Bit2 ~ 5, Bit7 and Bit14 ~ Bit15: Reserved, please set to 0.
- Bit0 ~ Bit1: Reserved.
- Bit6: In PT mode, the switch of pulse error protection function (pulse frequency is over high)

Bit6

Bit6 = 0: Normally use the function of pulse error protection
 Bit6 = 1: Disable the function of pulse error protection

- Bit8 : U, V, W wiring error protection

Bit8

Bit8 = 1: Enable U, V, W wiring error protection

- Bit9 : U, W, W wiring cut-off detection

Bit9

Bit9 = 1: Enable U, W, W wiring cut-off detection

- Bit 10: DI.ZCLAMP function selection

Bit10

When the following conditions are all established, the function of ZCLAMP is enabled.

Condition 1: speed mode

Condition 2: DI. ZCLAMP is On.

Condition 3: Motor speed is slower than the value of P1-38.

Bit10 = 0: The command source is analog, ZCLAMP function will use the analog speed command without acceleration / deceleration processing to judge if this function should be enabled. The motor will be locked at the position where ZCLAMP conditions are established.

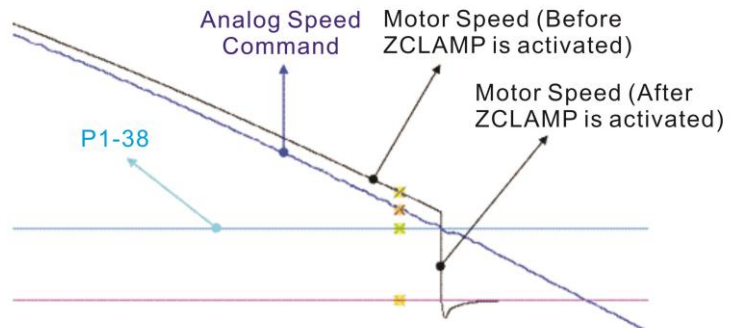

Bit10 = 0: The command source is register. ZCLAMP function will use the register speed command with acceleration / deceleration processing to judge if this function is enabled. The motor will be locked at the position where ZCALMP conditions are established.

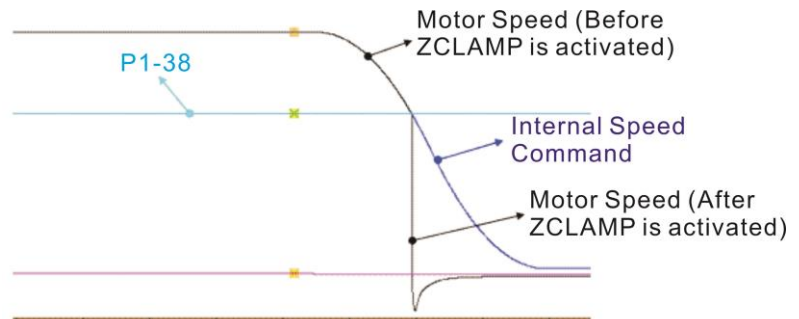

Bit10 = 1: The command source is analog speed command. ZCLAMP function will use the analog speed command without acceleration / deceleration processing to judge if this function is enabled. When ZCALMP conditions are established, the motor speed decelerates to 0 through S-curve. If not, the motor follow the analog speed command through S-curve.

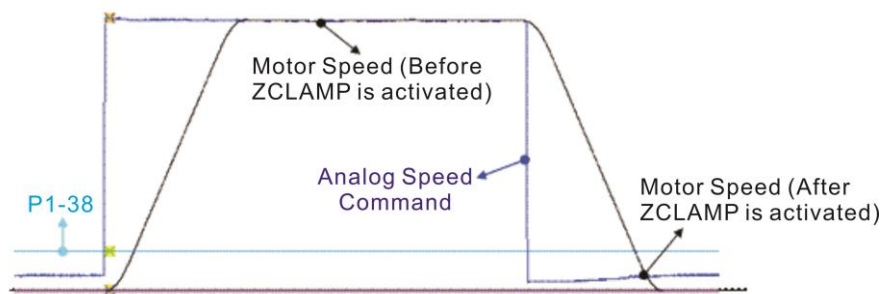
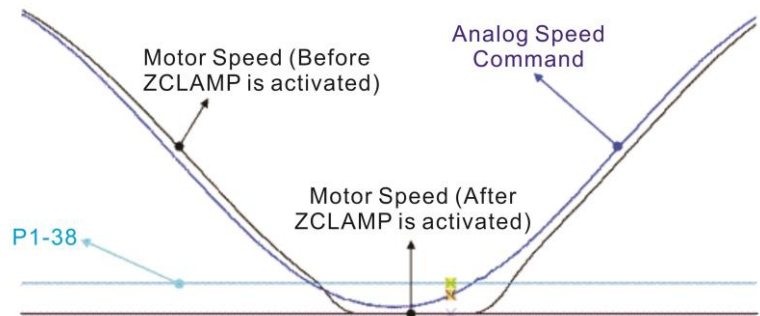

Bit10 = 1: The command source is register. ZCLAMP function will use the register with acceleration / deceleration processing to judge if this function is enabled. When ZCLAMP conditions are established, the motor speed will be set to 0.

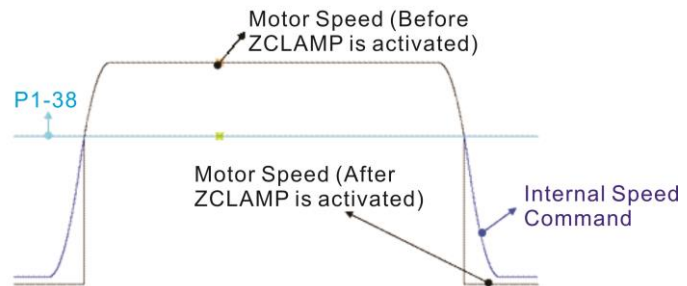

- Bit 11: Pulse inhibit function

Bit11

Bit11 = 0: Disalbe NL / PL pulse input inhibit function. In PT mode, the external position pulse command will be input into the servo drive in any condition.

Bit11 = 1: Enable NL / PL pulse input inhibit function. In PT mode, if NL exists, the external NL pulse will be inhibited to input to the servo. PL pulse input will be accepted. In PT mode, if PL exists, the external PL pulse will be inhibited to input to the servo. NL pulse will be accepted.

Please note: In PT mode, if NL and PL both exist, both of them will be inhibited to input to the servo.

- Bit12: Lack phase detection

Bit12

Bit12 = 0: Enable lack phase (AL022) detection

Bit12 = 1: Disable lack phase (AL022) detection

- Bit13: Encoder output error detection function

Bit13

Bit13 = 0: Enable encoder output error (AL018) detection function

Bit13 = 1: Disable encoder output error (AL018) detection function

- Bit15: Friction compensation mode selection

Bit15

Bit15 = 0: If the speed is slower than the value of P1-38, the compensation value remains.

Bit15 = 1: If the speed is slower than the value of P1-38, the compensation will become 0 according to the smoothing time of P1-63.

P2-66	GBIT2	Special-bit Register 2		Address: 0284H 0285H
	Operational Interface :	Panel / Software	Communication	Related Section: -
	Default :	0		
	Control Mode :	PT / PR / S		
	Unit :	-		
	Range :	0 ~ 0x000F		
	Data Size :	16bit		
	Format :	HEX		

Settings : Special-bit Register 2:

B7	B6	B5	B4	B3	B2	B1	B0
-	-	-	-	-	-	-	-

B0~B1: Reserved

B2: Cancel latch function of low-voltage error

0: Latch function of low-voltage error: the error will not be cleared automatically.

1: Cancel latch function of low-voltage error: the error will be cleared automatically.

B3: Reserved

B4: Cancel the detection of AL.044

0: AL.044 will occur

1: AL.044 will be ignored.

B5: Enable disconnection detection of linear scale (only when the full-closed loop control function is enabled)

0: AL.041 will be ignored

1: AL.041 will occur

B6~B7: Reserved

P2-67	JSL	The Stable Level of Inertia Estimation		Address: 0286H 0287H
	Operational Interface :	Panel / Software	Communication	Related Section: -
	Default :	1.5	15	
	Control Mode :	ALL		
Unit :	Permanent magnet synchronous rotary motor: 1times Permanent magnet synchronous linear motor: 1kg	Permanent magnet synchronous rotary motor: 0.1times Permanent magnet synchronous linear motor: 0.1kg		

Range :	0 ~ 200.0	0 ~ 2000
Data Size :	16bit	
Format :	One decimal	DEC
Example :	Permanent magnet synchronous rotary motor: 1.5 = 1.5 times Permanent magnet synchronous linear motor: 1.5 = 1.5kg	Permanent magnet synchronous rotary motor: 15 = 1.5 times Permanent magnet synchronous linear motor: 15 = 1.5kg

Settings : In semi-auto mode, if the value of inertia estimation is smaller than P2-67 and the status remains for a while, the system will regard the inertia estimation as completed.

P2-68	TEP	Switch of Following Error Compensation		Address: 0288H 0289H
	Operational Interface :	Panel / Software	Communication	Related Section: -
	Default :	0		
	Control Mode :	ALL		
	Unit :	-		
	Range :	0000h ~ 0x0001		
	Data Size :	16bit		
	Format :	HEX		

Settings : X = 0: P1-36 > 1, following error compensation is disabled.

1: P1-36 > 1, following error compensation is enabled.

(The function is available after V1.036 sub00)

Y = 0: When E-CAM is engaged, JOG cannot work.

1: When E-CAM is engaged, JOG can work.

(This function is not available now.)

Z = 0: DI.STP is triggered by rising edge.

1: DI.STP is Level triggered.

(The function is available after V1.042 sub00)

U = 0: AL.003 is WARNING

1: AL.003 is ALARM

(This function is not available now.)

P2-69	Reserved		Address: 028AH 028BH
P2-70	Reserved		Address: 028CH 028DH
P2-71	Reserved		Address: 028EH 028FH
P2-72	Reserved		Address: 0290H 0291H
P2-73	Reserved		Address: 0292H 0293H
P2-74	Reserved		Address: 0294H 0295H
P2-75	Reserved		Address: 0296H 0297H
P2-76	Reserved		Address: 0298H 0299H
P2-77	Reserved		Address: 029AH 029BH
P2-78	Reserved		Address: 029CH 029DH
P2-79	Reserved		Address: 029EH 029FH
P2-80	Reserved		Address: 02A0H 02A1H
P2-81	LPUS	Switch of Pulse Loss Detection	Address: 02A2H 02A3H
	Operational Interface :	Panel / Software Communication	Related Section: -
	Default :	1	
	Control Mode :	ALL	
	Unit :		
	Range :	0~1	
	Data Size :	16bit	
	Format :	DEC	
	Settings :	Set the parameter to 0 to disable the function; set it to 1 to enable it.	

P2-82	LPUL	Warning Level of Pulse Loss		Address: 02A4H 02A5H
	Operational Interface :	Panel / Software	Communication	Related Section: -
	Default :	10		
	Control Mode :	ALL		
	Unit :	pulse		
	Range :	0 ~ 32767		
	Data Size :	32bit		
	Format :	DEC		
Settings :	If the amount of pulse loss exceeds the setting level, it means the pulse loses too much and AL.057 will occur. ※This function is available only when motor travels through Z phase signal.			

P2-83		Level Checked via Z		Address: 02A6H 02A7H
	Operational Interface :	Panel / Software	Communication	Related Section: -
	Default :	2000		
	Control Mode :	ALL		
	Unit :	N/A		
	Range :	0 ~ 2 ³¹		
	Data Size :	32bit		
	Format :	DEC		
Settings :				

P2-84

LRSF	Special Function of Low Resolution		Address: 02A8H 02A9H
Operational Interface :	Panel / Software	Communication	Related Section: -
Default :	0X0000		
Control Mode :	ALL		
Unit :	N/A		
Range :	0 ~0x011F		
Data Size :	16bit		
Format :	HEX		
Settings :			

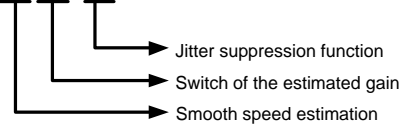
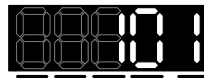

Jitter suppression function:

If motor resolution is lower, noise will occur when the motor stops. This function can help to reduce the noise. When the value is set to 0, this function is disabled. Set the value to 1 can enable this function. Bigger value brings better effect of suppression, but it sometimes brings bigger sound if users adjust the value too much.

Switch of the estimated gain: If motor resolution is lower and operates at low speed, it will cause noise. If this function is enabled and the motor speed is slower than 25 rpm, then the value of the estimated gain will become smaller. Thus, when the motor is at low speed, the operation will be more smoothing and reduce the noise that caused by the motor. Set the value to 0 to disable the function; while set to 1 can enable it.

Smooth speed estimation: If motor resolution is low, the estimated speed will be unable to operate smoothly. When enabling this function, it can help to smooth the operation. Set the value to 0 to disable the function; while set to 1 can enable it.

P3-xx Communication Parameters

P3-00	ADR	Address Setting		Address: 0300H 0301H
	Operational Interface :	Panel / Software	Communication	Related Section: 9.2
	Default :	0x7F		
	Control Mode :	ALL		
	Unit :	-		
	Range :	0x01 ~ 0x7F		
	Data Size :	16bit		
	Format :	HEX		

Settings : The communication address setting is divided into Y, X (hexadecimal):

	0	0	Y	X
Range	-	-	0 ~ 7	0 ~ F

When using RS-485 to communicate, one servo drive can only set one address. The duplicate address setting will cause abnormal communication.

This address represents the absolute address of the servo drive in communication network. It is also applicable to RS-485 and CAN bus.

When the communication address setting of MODBUS is set to 0xFF, the servo drive will automatically reply and receive data regardless of the address. However, P3-00 cannot be set to 0xFF.

P3-01	BRT	Transmission Speed		Address: 0302H 0303H
	Operational Interface :	Panel / Software	Communication	Related Section: 9.2
	Default :	0x0203		
	Control Mode :	ALL		
	Unit :	bps		
	Range :	0x0000 ~ 0x0405		
	Data Size :	16bit		
	Format :	HEX		

Settings : The setting of transmission speed is divided into Z, Y, X (hexadecimal):

	0	Z	Y	X
Communication Port	-	CAN	-	RS-485
Range	0	0~4	0	0~5

- Definition of X setting value
 - 0: 4800
 - 1: 9600
 - 2: 19200
 - 3: 38400
 - 4: 57600
 - 5: 115200
- Definition of Z setting value
 - 0: 125 Kbit/s
 - 1: 250 Kbit/s
 - 2: 500 Kbit/s
 - 3: 750 Kbit/s
 - 4: 1.0 Mbit/s

Note : 1) If this parameter is set via CAN, only Z can be set and the others remain.

2) The communication speed of USB is 1.0 Mbit/s only and is unchangeable.

P3-02	PTL	Communication Protocol	Address: 0304H 0305H
Operational Interface :	Panel / Software	Communication	Related Section: 9.2
Default :	6		
Control Mode :	ALL		
Unit :	-		
Range :	0 ~ 0x8		
Data Size :	16bit		
Format :	HEX		

Settings : The definition of the setting value is as the followings:

- 0: 7, N, 2 (MODBUS, ASCII)
- 1: 7, E, 1 (MODBUS, ASCII)
- 2: 7, O, 1 (MODBUS, ASCII)
- 3: 8, N, 2 (MODBUS, ASCII)
- 4: 8, E, 1 (MODBUS, ASCII)

- 5: 8, O, 1 (MODBUS, ASCII)
- 6: 8, N, 2 (MODBUS, RTU)
- 7: 8, E, 1 (MODBUS, RTU)
- 8: 8, O, 1 (MODBUS, RTU)

P3-03	FLT	Communication Error Disposal		Address: 0306H 0307H
Operational Interface :	Panel / Software	Communication		Related Section: 9.2
Default :	0			
Control Mode :	ALL			
Unit :	-			
Range :	0 ~ 0x1			
Data Size :	16bit			
Format :	HEX			

Settings : The definition of the setting value is as the following:
 0: Warning and keeps running
 1: Warning and stops deceleration (The deceleration time is set to parameter P5-03.B)

P3-04	CWD	Communication Timeout		Address: 0308H 0309H
Operational Interface :	Panel / Software	Communication		Related Section: 9.2
Default :	0			
Control Mode :	ALL			
Unit :	sec			
Range :	0 ~ 20			
Data Size :	16bit			
Format :	DEC			

Settings : If the setting value is not 0, enable communication timeout immediately. If it is set to 0, disable the function.

P3-05	CMM	Communication Mechanism	Address: 030AH 030BH
Operational Interface :	Panel / Software	Communication	Related Section: 9.2
Default :	0		
Control Mode :	ALL		
Unit :	-		
Range :	0x00 ~ 0x01		
Data Size :	16bit		
Format :	HEX		

Settings : Communication port can select one or more than one communications.

- Communication Interface
1: RS485

P3-06	SDI	Control Switch of Digital Input (DI)	Address: 030CH 030DH
Operational Interface :	Panel / Software	Communication	Related Section: 9.2
Default :	0		
Control Mode :	ALL		
Unit :	-		
Range :	0x0000 ~ 0x3FFF		
Data Size :	16bit		
Format :	HEX		

Settings : The source of DI controls the switch.

Each bit of this parameter decides one input source of DI signal:

Bit0 ~ Bit7 correspond to DI1 ~ DI8.

Bit8 ~ Bit13 correspond to extended DI EDI9 ~ EDI14;

The setting of bit is as the followings:

0: The input status is controlled by the external hardware.

1: The input status is controlled by P4-07.

For the functional planning of digital input, please refer to:

DI1 ~ DI8: P2-10 ~ P2-17

EDI9 ~ EDI14: P2-36 ~ P2-41

P3-07	CDT	Communication Response Delay Time		Address: 030EH 030FH
	Operational Interface :	Panel / Software	Communication	Related Section: 9.2
	Default :	0		
	Control Mode :	ALL		
	Unit :	1ms		
	Range :	0 ~ 1000		
	Data Size :	16bit		
	Format :	DEC		

Settings : Delay the time of communication response from servo drive to controller

P3-08	MNS	Monitor Mode		Address: 0310H 0311H
	Operational Interface :	Panel / Software	Communication	Related Section: 9.2
	Default :	0000		
	Control Mode :	ALL		
	Unit :	-		
	Range :	Shown as below		
	Data Size :	16bit		
	Format :	HEX		

Settings : The setting of monitor mode is divided into L and H. (hexadecimal):

Item	-	-	L	H
Function	-	-	Low-speed monitoring time	Monitor Mode
Range	0	0	0 ~ F	0 ~ 3

The status of this axis or multi-axis can be monitored by USB. The definition of setting value is as follows:

- The definition of H setting value
 - 3: USB is high-speed monitor. The sampling frequency is 16K and can only monitor 2CH.
 - 2: USB is high-speed monitor. The sampling frequency is 8K and can monitor 4CH.
 - 1: USB is low-speed monitor. The sampling time is set by L and can monitor 4CH.
 - 0: disable the monitor function
- L: the sampling time of USB low-speed monitor. Its unit is ms. It means the axial status will be set via USB every L ms. So the controller can monitor the axial status. Each monitoring message includes 4 CH data (16 bit x 4). If L is set to 0, this function is disabled. L is enabled when H is set to 1.

P3-09	SYC	CANopen Synchronize Setting		Address: 0312H 0313H
	Operational Interface :	Panel / Software	Communication	Related Section: 9.2
	Default :	0x57A1		
	Control Mode :	CANopen		
	Unit :	-		
	Range :	Shown as below		
	Data Size :	16bit		
	Format :	HEX		

Settings : The synchronous setting of CANopen is divided into E, T, D and M (hexadecimal):

Item	E	T	D	M
Function	Range of Synchronous error	Target Value	Deadband	Adjusting amount
Range	1 ~ 9	0 ~ 9	0 ~ F	1 ~ F

The slave of CANopen synchronizes with the master via SYNC. See as the followings:

M: If the slave needs to synchronize with the master, correct the clock is a must. This parameter sets the maximum correction value per time. (Unit: usec)

D: Set the size of deadband (Unit: usec). If the deviation between the SYNC reaching time and the target value does not exceed the deadband, correction is no need.

T: SYNC arrival time. The standard value is 500usec but it might be different from the target value. Thus, the buffer is necessary.

$$\text{Target value} = 400 + 10 \times T.$$

For instance, if T=5, the target value will be 450.

E: If the deviation between SYNC reaching time and the target value is smaller than the range, it means the synchronization is successful. (Unit: 10 usec)

P3-10	Reserved	Address: 0314H 0315H
P3-11	Reserved	Address: 0316H 0317H

P4-xx Diagnosis Parameters

P4-00★	ASH1	Fault Record (N)	Address: 0400H 0401H
	Operational Interface :	Panel / Software Communication	Related Section: 4.4.1
	Default :	0	
	Control Mode :	ALL	
	Unit :	-	
	Range :	-	
	Data Size :	32bit	
	Format :	HEX	
	Settings :	The last abnormal status record Low word: LXXXX: display ALM number High word: hYYYY: display the error code corresponds to CANopen	

P4-01★	ASH2	Fault Record (N-1)	Address: 0402H 0403H
	Operational Interface :	Panel / Software Communication	Related Section: 4.4.1
	Default :	0	
	Control Mode :	ALL	
	Unit :	-	
	Range :	-	
	Data Size :	32bit	
	Format :	HEX	
	Settings :	The last second abnormal status record Low word: LXXXX: display ALM number High word word: hYYYY: display the error code corresponds to CANopen	

P4-02★	ASH3	Fault Record (N-2)	Address: 0404H 0405H
	Operational Interface :	Panel / Software Communication	Related Section: 4.4.1
	Default :	0	

Control Mode :	ALL
Unit :	-
Range :	-
Data Size :	32bit
Format :	HEX

Settings : The last third abnormal status record
 Low word: LXXXX: display ALM number
 High word: hYYYY: display the error code corresponds to CANopen

P4-03★	ASH4	Fault Record (N-3)	Address: 0406H 0407H
	Operational Interface :	Panel / Software	Communication
	Default :	0	
	Control Mode :	ALL	
	Unit :	-	
	Range :	-	
	Data Size :	32bit	
	Format :	HEX	
	Settings :	The last fourth abnormal status record Low word: LXXXX: display ALM number High word: hYYYY: display the error code corresponds to CANopen	

Related Section:
4.4.1

P4-04★	ASH5	Fault Record (N-4)	Address: 0408H 0409H
	Operational Interface :	Panel / Software	Communication
	Default :	0	
	Control Mode :	ALL	
	Unit :	-	
	Range :	-	
	Data Size :	32bit	
	Format :	HEX	
	Settings :	The last fourth abnormal status record Low word: LXXXX: display ALM number High word: hYYYY: display the error code corresponds to CANopen	

Related Section:
4.4.1

Settings : The last fifth abnormal status record

Low word: LXXXX: display ALM number

High word: hYYYY: display the error code corresponds to CANopen

P4-05	JOG	Servo Motor Jog Control	Address: 040AH 040BH
Operational Interface :	Panel / Software	Communication	Related Section: 4.4.2
Default :	20		
Control Mode :	ALL		
Unit :	Permanent magnet synchronous rotary motor: rpm Permanent magnet synchronous linear motor: 10^{-3} m/s		
Range :	Permanent magnet synchronous rotary motor: 0 ~ 5000 Permanent magnet synchronous linear motor: 0~15999		
Data Size :	16bit		
Format :	DEC		

Settings : Three control methods are as follows:

1. Operation Test

After the JOG speed is set by P4-05 via panel, the panel will display the symbol of JOG. Pressing the UP Key can control JOG operation in positive direction, pressing the DOWN Key can control negative direction. Stop pressing to stop the JOG operation. If there is any error in this setting, then the motor cannot operate. The maximum JOG speed is the maximum speed of the servo motor.

2. DI Control

If the DI is set to JOGU and JOGD (refer to table 7.1), then the JOG operation in positive or negative direction can be controlled via this DI.

3. Communication Control

1 ~ 5000: JOG speed

4998: JOG operation in positive direction

4999: JOG operation in negative direction

0: Stop operation

Note : When writing via communication, if the frequency is high, please set P2-30 to 5.

P4-06 ▲ ■	FOT	Digital Output Register (Readable and Writable)	Address: 040CH 040DH
Operational Interface :	Panel / Software	Communication	Related Section: 4.4.3
Default :	0		
Control Mode :	ALL		
Unit :	-		
Range :	0 ~ 0xFF		
Data Size :	16bit		
Format :	HEX		
Settings :	bit 00: correspond to DO code=0x30 bit 01: correspond to DO code=0x31 bit 02: correspond to DO code=0x32 bit 03: correspond to DO code=0x33 bit 04: correspond to DO code=0x34 bit 05: correspond to DO code=0x35 bit 06: correspond to DO code=0x36 bit 07: correspond to DO code=0x37 bit 08: correspond to DO code=0x38 bit 09: correspond to DO code=0x39 bit 10: correspond to DO code=0x3A bit 11: correspond to DO code=0x3B bit 12: correspond to DO code=0x3C bit 13: correspond to DO code=0x3D bit 14: correspond to DO code=0x3E bit 15: correspond to DO code=0x3F If P2-18 is set to 0x0130, then the DO#1 is bit 0 status of P4-06. DO Code (0x30~0x3F) can be set via communication DO, and then write into P4-06.		

P4-07 ■	ITST	Multi-function of Digital Input	Address: 040EH 040FH
Operational Interface :	Panel / Software	Communication	Related Section: Section 4.4.4 Table 9.2
Default :	0		
Control Mode :	ALL		
Unit :	-		
Range :	0 ~ 0x3FFF		

Data Size :	16bit
Format :	HEX

Settings : The DI input signal can come from external terminal (DI1 ~ DI8; EDI9 ~ EDI14) or software SDI1 ~ 14 (Bit 0 ~ 13 of corresponding parameter P4-07) and is determined by P3-06. The corresponding bit of P3-06 is 1, which means the source is software SDI (P4-07). If the corresponding bit is 0, then the source is hardware DI. See the following graph:

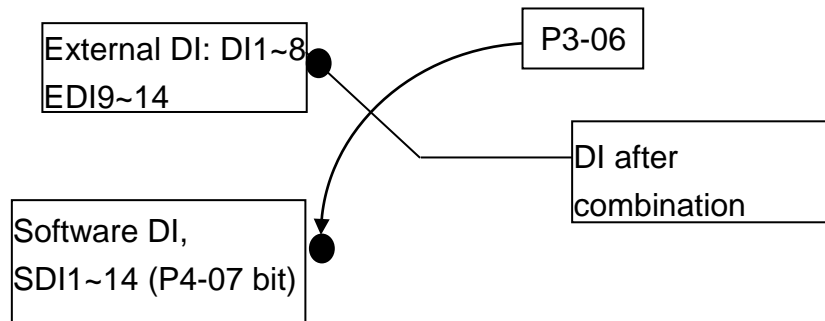

Read parameters: shows the DI status after combination

Write parameters: writes the software SDI status

For example:

The value of reading P4-07 is 0x0011, which means DI1 and DI5 is ON after combination.

The value of writing P4-07 is 0x0011, which means software SDI1 and SDI5 is ON.

Please refer to P2-10 ~ P2-17 for the function programme of digital input pin DI (DI1~DI8) and P2-36 ~ P2-41 for extended DI (EDI9 ~ EDI14).

P4-08★	PKEY	Input Status of the Drive Keypad (Read-only)		Address: 0410H 0411H
	Operational Interface :	Panel / Software	Communication	Related Section: -
	Default :	-		
	Control Mode :	ALL		
	Unit :	-		
	Range :	(read-only)		
	Data Size :	16bit		
	Format :	HEX		

Settings : The aim is to check if the five Keys, MODE, UP, DOWN, SHIFT and SET can work normally. This parameter is also used to check if the Keys are all functional when producing servo drives.

P4-09★	MOT	Digital Output Status (Read-only)		Address: 0412H 0413H
	Operational Interface :	Panel / Software	Communication	Related Section: 4.4.5
	Default :	-		
	Control Mode :	ALL		
	Unit :	-		
	Range :	0 ~ 0x1F		
	Data Size :	16bit		
	Format :	HEX		
Settings :	Note: There is no difference whether read by panel or communication.			

P4-10■	CEN	Adjustment Selection		Address: 0414H 0415H
	Operational Interface :	Panel / Software	Communication	Related Section: -
	Default :	0		
	Control Mode :	ALL		
	Unit :	-		
	Range :	0 ~ 6		
	Data Size :	16bit		
	Format :	DEC		
Settings :	0: reserved			

- 1: Execute the adjustment of analog speed input offset
- 2: Execute the adjustment of analog torque input offset
- 3: Execute the adjustment of current detector (V phase) hardware offset
- 4: Execute the adjustment of current detector (W phase) hardware offset
- 5: Execute the adjustment of 1~4 hardware offset
- 6: Execute the adjustment of IGBT ADC

Note : The adjustment function needs to be enabled by the setting of parameter P2-08. When adjusting, the external wiring which connects to analog speed or torque (force) needs to be removed completely and must be in Servo Off status.

P4-11	SOF1	Analog Speed Input Offset Adjustment 1		Address: 0416H 0417H
	Operational Interface :	Panel / Software	Communication	
Default :	Factory default			
Control Mode :	ALL			
Unit :	-			
Range :	0 ~ 32767			
Data Size :	16bit			
Format :	DEC			

Settings : Manually adjust the hardware offset. The adjustment function needs to be enabled by the setting of parameter P2-08. It is not suggested to adjust the auxiliary adjustment. This parameter cannot be reset.

P4-12	SOF2	Analog Speed Input Offset Adjustment 2		Address: 0418H 0419H
	Operational Interface :	Panel / Software	Communication	
Default :	Factory default			
Control Mode :	ALL			
Unit :	-			
Range :	0 ~ 32767			
Data Size :	16bit			
Format :	DEC			

Settings : Manually adjust the hardware offset. The adjustment function needs to be enabled by the setting of parameter P2-08. It is not suggested to adjust the auxiliary adjustment. This parameter cannot be reset.

P4-13	TOF1	Analog Torque Input Offset Adjustment 1		Address: 041AH 041BH
	Operational Interface :	Panel / Software	Communication	
Default :	Factory default			
Control Mode :	ALL			
Unit :	-			

Range :	0 ~ 32767
Data Size :	16bit
Format :	DEC

Settings : Manually adjust the hardware offset. The adjustment function needs to be enabled by the setting of parameter P2-08. It is not suggested to adjust the auxiliary adjustment. This parameter cannot be reset.

P4-14	TOF2	Analog Torque Input Offset Adjustment 2	Address: 041CH 041DH
--------------	-------------	--	---------------------------------

Operational Interface :	Panel / Software	Communication	Related Section: -
Default :	Factory default		
Control Mode :	ALL		
Unit :	-		
Range :	0 ~ 32767		
Data Size :	16bit		
Format :	DEC		

Settings : Manually adjust the hardware offset. The adjustment function needs to be enabled by the setting of parameter P2-08. It is not suggested to adjust the auxiliary adjustment. This parameter cannot be reset.

P4-15	COF1	Current Detector (V1 Phase) Offset Adjustment	Address: 041EH 041FH
--------------	-------------	--	---------------------------------

Operational Interface :	Panel / Software	Communication	Related Section: -
Default :	Factory default		
Control Mode :	ALL		
Unit :	-		
Range :	0 ~ 32767		
Data Size :	16bit		
Format :	DEC		

Settings : Manually adjust the hardware offset. The adjustment function needs to be enabled by the setting of parameter P2-08. It is not suggested to adjust the auxiliary adjustment. This parameter cannot be reset.

P4-16	COF2	Current Detector (V2 Phase) Offset Adjustment		Address: 0420H 0421H
	Operational Interface :	Panel / Software	Communication	Related Section: -
Default :	Factory default			
Control Mode :	ALL			
Unit :	-			
Range :	0 ~ 32767			
Data Size :	16bit			
Format :	DEC			

Settings : Manually adjust the hardware offset. The adjustment function needs to be enabled by the setting of parameter P2-08. It is not suggested to adjust the auxiliary adjustment. This parameter cannot be reset.

P4-17	COF3	Current Detector (W1 Phase) Offset Adjustment		Address: 0422H 0423H
	Operational Interface :	Panel / Software	Communication	Related Section: -
Default :	Factory default			
Control Mode :	ALL			
Unit :	-			
Range :	0 ~ 32767			
Data Size :	16bit			
Format :	DEC			

Settings : Manually adjust the hardware offset. The adjustment function needs to be enabled by the setting of parameter P2-08. It is not suggested to adjust the auxiliary adjustment. This parameter cannot be reset.

P4-18	COF4	Current Detector (W2 Phase) Offset Adjustment		Address: 0424H 0425H
	Operational Interface :	Panel / Software	Communication	Related Section: -
Default :	Factory default			
Control Mode :	ALL			
Unit :	-			

Range :	0 ~ 32767
Data Size :	16bit
Format :	DEC

Settings : Manually adjust the hardware offset. The adjustment function needs to be enabled by the setting of parameter P2-08. It is not suggested to adjust the auxiliary adjustment. This parameter cannot be reset.

P4-19	TIGB	IGBT NTC Adjustment Detection Level (cannot reset)	Address: 0426H 0427H
	Operational Interface :	Panel / Software Communication	Related Section: -
	Default :	Factory default	
	Control Mode :	ALL	
	Unit :	-	
	Range :	1 ~ 4	
	Data Size :	16bit	
	Format :	DEC	

Settings : Please cool down the drive to 25 Celsius degree when adjusting

P4-20	DOF1	Offset Adjustment Value of Analog Monitor Output (Ch1)	Address: 0428H 0429H
	Operational Interface :	Panel / Software Communication	Related Section: 6.4.4
	Default :	0	
	Control Mode :	ALL	
	Unit :	mV	
	Range :	-800 ~ 800	
	Data Size :	16bit	
	Format :	DEC	

Settings : Offset adjustment value (cannot reset)

P4-21	DOF2	Offset Adjustment Value of Analog Monitor Output (Ch2)		Address: 042AH 042BH
	Operational Interface :	Panel / Software	Communication	Related Section: 6.4.4
Default :	0			
Control Mode :	ALL			
Unit :	mV			
Range :	-800 ~ 800			
Data Size :	16bit			
Format :	DEC			
Settings :	Offset adjustment value (cannot reset)			

P4-22	SAO	Analog Speed Input OFFSET		Address: 042CH 042DH
	Operational Interface :	Panel / Software	Communication	Related Section: -
Default :	0			
Control Mode :	S			
Unit :	mV			
Range :	-5000 ~ 5000			
Data Size :	16bit			
Format :	DEC			
Settings :	Users manually adjust the OFFSET			

P4-23	TAO	Analog Torque (Force) Input OFFSET		Address: 042EH 042FH
	Operational Interface :	Panel / Software	Communication	Related Section: -
	Default :	0		
	Control Mode :	T		
	Unit :	mV		
	Range :	-5000 ~ 5000		
	Data Size :	16bit		
	Format :	DEC		

Settings : Users manually adjust the OFFSET

P4-24	LVL	Level of Undervoltage Error		Address: 0430H 0431H
	Operational Interface :	Panel / Software	Communication	Related Section: -
	Default :	160		
	Control Mode :	ALL		
	Unit :	V (rms)		
	Range :	140~190		
	Data Size :	16bit		
	Format :	DEC		

Settings : When the voltage of DC BUS is lower than $P4-24 * \sqrt{2}$, the undervoltage alarm occurs.

P5-xx Motion Setting Parameters

P5-00	Reserved	Address: 0500H 0501H
--------------	----------	-------------------------

P5-01	Reserved	Address: 0502H 0503H
--------------	----------	-------------------------

P5-02	Reserved	Address: 0504H 0505H
--------------	----------	-------------------------

P5-03	PDEC	Deceleration Time of Auto Protection	Address: 0506H 0507H
--------------	-------------	---	-------------------------

Operational Interface :	Panel / Software	Communication	Related Section: -
Default :	0XE0EFEEFF		
Control Mode :	ALL		
Unit :	-		
Range :	0x00000000 ~ 0xF0FFFFFF		
Data Size :	32bit		
Format :	HEX		

Settings : The parameter setting is divided into D, C, B, A, W, Z, Y, X (hexadecimal), including:

1. The deceleration time when activating the auto-protection function: OVF, CTO (communication timeout AL020), SPL, SNL, PL, NL

2. Deceleration time of Stop Command: STP

Item	D	C	B	A	W	Z	Y	X
Function	STP	Reserved	CTO	OVF	SNL	SPL	NL	PL
Range	0 ~ F	-	0 ~ F	0 ~ F	0 ~ F	0 ~ F	0 ~ F	0 ~ F

0 ~ F is used to indexing the deceleration time of P5-20~P5-35.

For example: If X is set to A, then the deceleration time of PL is determined by P5-30.

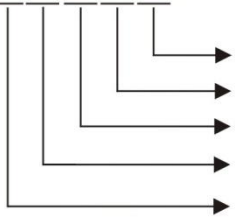
P5-04	HMOV	Homing Mode		Address: 0508H 0509H
	Operational Interface :	Panel / Software	Communication	Related Section: -
	Default :	0		
	Control Mode :	PR		
	Unit :	-		
	Range :	0 ~ 0x128		
	Data Size :	16bit		
	Format :	HEX		
	Settings :			
				

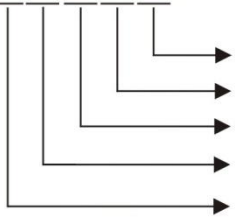

- X: Homing method
- Y: Z pulse setting
- Z: Limit setting
- W: Reserved
- Not in use

The definition of the setting value is as the followings:

W	Z	Y	X
Reserved	Limit Setting	Z pulse Setting	Homing Method
-	0 ~ 1	0 ~ 2	0 ~ 8
<p>When encounter limit: Z=0: shows error Z=1: rotates backwards</p>		Y=0: Stop and return to Z pulse	X=0: Homing in forward direction and regard PL as the homing origin.
		Y=1: Go forward to Z pulse Y=2: Do not look for Z pulse	X=1: Homing in reverse direction and regard NL as the homing origin.
			X=2: Homing in forward direction ORGP: OFF → ON, as the homing origin
			X=3: Homing in reverse direction ORGP: OFF → ON, as the homing origin
			X=4: Look for Z pulse in forward direction and regard it as the homing origin
			X=5: Look for Z pulse in reverse direction and regard it as the homing origin
		Y=0: Stop and return to Z pulse Y=1: Go forward to Z pulse Y=2: Do not look for Z pulse	X=6: Homing in forward direction ORGP: ON → OFF, as the homing origin
			X=7: Homing in reverse direction ORGP: ON → OFF, as the homing origin
			X=8: directly define the current position as the origin

P5-05	HSPD1 1st Speed Setting of High Speed Homing		Address: 050AH 050BH
	Operational Interface :	Panel / Software	Communication
	Default :	100.0	1000
	Control Mode :	ALL	
	Unit :	Permanet magnet synchronous rotary motor: 1rpm Permanet magnet synchronous linear motor: 10 ⁻⁶ m/s	Permanet magnet synchronous rotary motor: 0.1rpm Permanet magnet synchronous linear motor: 10 ⁻⁶ m/s
	Range :	Permanet magnet synchronous rotary motor: 0.1 ~ 2000.0 Permanet magnet synchronous linear motor: 1~15999999	Permanet magnet synchronous rotary motor: 1 ~ 20000 Permanet magnet synchronous linear motor: 1~15999999
	Data Size :	32bit	
	Format :	DEC	
	Example :	Permanent magnet synchronous rotary motor: 1.5 = 1.5 r/min Permanent magnet synchronous linear motor: 1500.0 = 0.015m/s	Permanent magnet synchronous rotary motor: 15 = 1.5 r/min Permanent magnet synchronous linear motor: 15000 = 0.015m/s

Related Section: -

Settings : The 1st speed of high speed homing

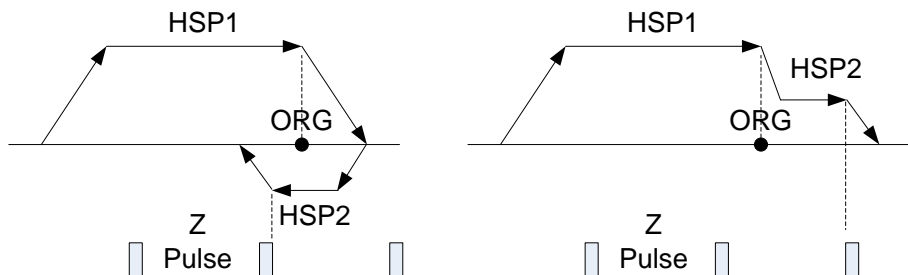

P5-06	HSPD2 2 nd Speed Setting of Low Speed Homing		Address: 050CH 050DH
	Operational Interface :	Panel / Software	Communication
Default :	20.0	200	
Control Mode :	ALL		
Unit :	Permanent magnet synchronous rotary motor: 1rpm Permanent magnet synchronous linear motor: 10 ⁻⁶ m/s	Permanent magnet synchronous rotary motor: 0.1rpm Permanent magnet synchronous linear motor: 10 ⁻⁶ m/s	
Range :	Permanent magnet synchronous rotary motor: 0.1 ~ 2000.0 Permanent magnet synchronous linear motor: 1~15999999	Permanent magnet synchronous rotary motor: 1 ~ 20000 Permanent magnet synchronous linear motor: 1~15999999	
Data Size :	32bit		
Format :	DEC		
Example :	Permanent magnet synchronous rotary motor: 1.5 = 1.5 r/min Permanent magnet synchronous linear motor: 1500.0 = 0.015m/s	Permanent magnet synchronous rotary motor: 15 = 1.5 r/min Permanent magnet synchronous linear motor: 15000 = 0.015m/s	

Settings : The 2nd speed setting of low speed homing

P5-07	PRCM Trigger Position Command (PR mode only)		Address: 050EH 050FH
	Operational Interface :	Panel / Software	Communication
Default :	0		
Control Mode :	PR		
Unit :	-		
Range :	0 ~ 1000		
Data Size :	16bit		
Format :	DEC		

Settings : Set P5-07 to 0 to start homing
 Set P5-07 to 1~63 to execute PR procedure which is the same as DI.CTRG+POS_n
 It is prohibited to set P5-07 to 64 ~ 9999 (The value exceeds the valid range)
 Set P5-07 to 1000 to execute Stop Command which is the same as DI.STOP
 When reading P5-07:
 If the command is incompleted, the drive will read the current command.
 If the command is completed, the drive will read the current command + 10000.
 If the command is completed and DO.TPOS is ON, reach the motor position, the drive will read the current command +20000.
 When PR is triggered by DI, the reading value is the same
 For example:
 Set P5-07 to 3, PR#3 will be triggered.
 If the reading value is 3, it means PR #3 is incompleted.
 If the reading value is 10003, it means PR#3 is issued completed, but the motor has not reached the target position yet.
 If the reading value is 20003, it means PR#3 is issued completed and the motor has reached the target position.

P5-08	SWLP	Forward Software Limit		Address: 0510H 0511H
	Operational Interface :	Panel / Software	Communication	Related Section: -
	Default :	2147483647		
	Control Mode :	PR		
	Unit :	PUU		
	Range :	-2147483648 ~ +2147483647		
	Data Size :	32bit		
	Format :	DEC		

Settings : In PR mode, if the motor rotates in forward direction and its command position exceeds the setting value of P5-08, it will trigger AL.283.

P5-09	SWLN	Reverse Software Limit		Address: 0512H 0513H
	Operational Interface :	Panel / Software	Communication	
Default :	-2147483648			
Control Mode :	PR			
Unit :	PUU			
Range :	-2147483648 ~ +2147483647			
Data Size :	32bit			
Format :	DEC			
Settings :	In PR mode, if the motor rotates in reverse direction and its command position exceeds the setting value of P5-09, it will trigger AL.285.			

P5-10★	AYSZ	Data Array - Data Size		Address: 0514H 0515H
	Operational Interface :	Panel / Software	Communication	
Default :	-			
Control Mode :	ALL			
Unit :	-			
Range :	Read-only			
Data Size :	16bit			
Format :	DEC			
Settings :	Data size (N x 32 bits) means size N of data array			

P5-11■	AYID	Data Array - Address of Reading / Writing		Address: 0516H 0517H
	Operational Interface :	Panel / Software	Communication	
Default :	0			
Control Mode :	ALL			
Unit :	-			
Range :	0 ~ (value set by P5-10 minus 1)			
Data Size :	16bit			

Format :	DEC
----------	-----

Settings : The address of specified data when reading or writing data array.

P5-12	AYD0	Data Array - Window #1 for Reading / Writing		Address: 0518H 0519H
	Operational Interface :	Panel / Software	Communication	Related Section: 7.2
	Default :	0		
	Control Mode :	ALL		
	Unit :	-		
	Range :	-2147483648 ~ +2147483647		
	Data Size :	32bit		
	Format :	DEC		

Settings : Window #1 (Array[P5-11++])
When reading the parameter via panel, the value set by P5-11 will not add 1, but the others will.

P5-13	AYD1	Data Array - Window #2 for Reading / Writing		Address: 051AH 051BH
	Operational Interface :	Panel / Software	Communication	Related Section: 7.2
	Default :	0		
	Control Mode :	ALL		
	Unit :	-		
	Range :	-2147483648 ~ +2147483647		
	Data Size :	32bit		
	Format :	DEC		

Settings : Window #2 (Array[P5-11++])
When reading and writing the parameter via panel or communication, the value set by P5-11 will add 1. Panel is write-protected.

P5-14	Reserved	Address : 051CH 051DH
--------------	-----------------	----------------------------------

P5-15

PMEM	PATH#1 ~ PATH#2 No Data Retained Setting		Address: 051EH 051FH
Operational Interface :	Panel / Software	Communication	Related Section: -
Default :	0x0		
Control Mode :	ALL		
Unit :	-		
Range :	0x0 ~ 0x0011		
Data Size :	16bit		
Format :	HEX		

Settings : The parameter is divided into 00YX:

X=0: PATH#1 Data retained

X=1: PATH#1 No data retained

Y=0: PATH#2 Data retained

Y=1: PATH#2 No data retained

Others are reserved

Users can continuously write the new position into the drive through communication by P5-05.

P5-16

AXEN	Axis Position - Motor Encoder		Address: 0520H 0521H
Operational Interface :	Panel / Software	Communication	Related Section: 7.3
Default :	0		
Control Mode :	ALL		
Unit :	PUU (User position unit)		
Range :	-2147483648 ~ +2147483647		
Data Size :	32bit		
Format :	DEC		

Settings : Read: The feedback position of the motor encoder, which is the monitor various V000 + the offset value.

Write: Any value can be written into the parameter and will neither change V000 nor influence the positioning coordinate system. It is only for observation when adjusting the offset value.

P5-17	AXAU	Axis Position - Auxiliary Encoder		Address: 0522H 0523H
	Operational Interface :	Panel / Software	Communication	Related Section: 7.3
	Default :	-		
	Control Mode :	ALL		
	Unit :	Pulse number		
	Range :	-2147483648 ~ +2147483647		
	Data Size :	32bit		
	Format :	DEC		
	Settings :	Sends back: pulse counts of the auxiliary encoder (linear scale)		

P5-18	AXPC	Axis Position - Pulse Command		Address: 0524H 0525H
	Operational Interface :	Panel / Software	Communication	Related Section: 7.3
	Default :	-		
	Control Mode :	ALL		
	Unit :	Pulse number		
	Range :	-2147483648 ~ +2147483647		
	Data Size :	32bit		
	Format :	DEC		
	Settings :	Sends back: pulse counts of pulse command		

P5-19	TBS	E-Cam Curve Scaling		Address: 0526H 0527H
	Operational Interface :	Panel / Software	Communication	Related Section: -
	Default :	1.000000		
	Control Mode :	PR		
	Unit :	0.000001 times, which is 1 / (10 ⁶)		
	Range :	-2147.000000 ~ +2147.000000		
	Data Size :	32 bit		
	Format :	DEC		

Example : 1100000 = 1.1 times

Settings : (It will be provided after firmware version V1.017)
 This parameter is used to magnify or minify the E-Cam table without changing its setting value.

For example, the data in the table is 0,10,20,30,40,20, magnification x 2.000000 equals to the data in the table: 0,20,40,60,80,40, magnification x 1.000000.

Enable the operation of E-Cam by using the same pulse frequency of the master axis. Magnify the magnification will enlarge the route of E-Cam operation. The speed will be magnified as well.

Note : This parameter can be set anytime, but will be effective only when pre-engaged → engaged.

P5-20	AC0	Acceleration/Deceleration Time (Number #0)		Address: 0528H 0529H
	Operational Interface :	Panel / Software	Communication	Related Section: 7.10
	Default :	200		
	Control Mode :	PR		
	Unit :	ms		
	Range :	1 ~ 65500		
	Data Size :	16bit		
	Format :	DEC		

Settings : Permanent magnet synchronous rotary motor:
 The setting time of acceleration/deceleration in PR mode, which is the time it needs when accelerating from 0 to 3000r/min
 Permanent magnet synchronous linear motor:
 The setting time of acceleration/deceleration in PR mode, which is the time it needs when accelerating from 0 to 5 m/s.

P5-21	AC1	Acceleration/Deceleration Time (Number #1)		Address: 052AH 052BH
	Operational Interface :	Panel / Software	Communication	Related Section: 7.10
	Default :	300		
	Control Mode :	PR		
	Unit :	ms		

Range :	1 ~ 65500
Data Size :	16bit
Format :	DEC

Settings : Please refer to P5-20 for the setting of acceleration/deceleration time in PR mode.

P5-22	AC2	Acceleration/Deceleration Time (Number #2)		Address: 052CH 052DH
	Operational Interface :	Panel / Software	Communication	Related Section: 7.10
	Default :	500		
	Control Mode :	PR		
	Unit :	ms		
	Range :	1 ~ 65500		
	Data Size :	16bit		
	Format :	DEC		

Settings : Please refer to P5-20 for the setting of acceleration/deceleration time in PR mode.

P5-23	AC3	Acceleration/Deceleration Time (Number #3)		Address: 052EH 052FH
	Operational Interface :	Panel / Software	Communication	Related Section: 7.10
	Default :	600		
	Control Mode :	PR		
	Unit :	ms		
	Range :	1 ~ 65500		
	Data Size :	16bit		
	Format :	DEC		

Settings : Please refer to P5-20 for the setting of acceleration/deceleration time in PR mode.

P5-24	AC4	Acceleration/Deceleration Time (Number #4)		Address: 0530H 0531H
	Operational Interface :	Panel / Software	Communication	Related Section: 7.10
	Default :	800		
	Control Mode :	PR		
	Unit :	ms		
	Range :	1 ~ 65500		
	Data Size :	16bit		
	Format :	DEC		
Settings :	Please refer to P5-20 for the setting of acceleration/deceleration time in PR mode.			

P5-25	AC5	Acceleration/Deceleration Time (Number #5)		Address: 0532H 0533H
	Operational Interface :	Panel / Software	Communication	Related Section: 7.10
	Default :	900		
	Control Mode :	PR		
	Unit :	ms		
	Range :	1 ~ 65500		
	Data Size :	16bit		
	Format :	DEC		
Settings :	Please refer to P5-20 for the setting of acceleration/deceleration time in PR mode.			

P5-26	AC6	Acceleration/Deceleration Time (Number #6)		Address: 0534H 0535H
	Operational Interface :	Panel / Software	Communication	Related Section: 7.10
	Default :	1000		
	Control Mode :	PR		
	Unit :	ms		
	Range :	1 ~ 65500		
	Data Size :	16bit		
Settings :	Please refer to P5-20 for the setting of acceleration/deceleration time in PR mode.			

Format :	DEC
----------	-----

Settings : Please refer to P5-20 for the setting of acceleration/deceleration time in PR mode.

P5-27	AC7	Acceleration/Deceleration Time (Number #7)		Address: 0536H 0537H
	Operational Interface :	Panel / Software	Communication	Related Section: 7.10
	Default :	1200		
	Control Mode :	PR		
	Unit :	ms		
	Range :	1 ~ 65500		
	Data Size :	16bit		
	Format :	DEC		

Settings : Please refer to P5-20 for the setting of acceleration/deceleration time in PR mode.

P5-28	AC8	Acceleration/Deceleration Time (Number #8)		Address: 0538H 0539H
	Operational Interface :	Panel / Software	Communication	Related Section: 7.10
	Default :	1500		
	Control Mode :	PR		
	Unit :	ms		
	Range :	1 ~ 65500		
	Data Size :	16bit		
	Format :	DEC		

Settings : Please refer to P5-20 for the setting of acceleration/deceleration time in PR mode.

P5-29	AC9	Acceleration/Deceleration Time (Number #9)		Address: 053AH 053BH
	Operational Interface :	Panel / Software	Communication	Related Section: 7.10
	Default :	2000		
	Control Mode :	PR		

Unit :	ms
Range :	1 ~ 65500
Data Size :	16bit
Format :	DEC

Settings : Please refer to P5-20 for the setting of acceleration/deceleration time in PR mode.

P5-30	AC10	Acceleration/Deceleration Time (Number #10)		Address: 053CH 053DH
	Operational Interface :	Panel / Software	Communication	Related Section: 7.10
	Default :	2500		
	Control Mode :	PR		
	Unit :	ms		
	Range :	1 ~ 65500		
	Data Size :	16bit		
	Format :	DEC		

Settings : Please refer to P5-20 for the setting of acceleration/deceleration time in PR mode.

P5-31	AC11	Acceleration/Deceleration Time (Number #11)		Address: 053EH 053FH
	Operational Interface :	Panel / Software	Communication	Related Section: 7.10
	Default :	3000		
	Control Mode :	PR		
	Unit :	ms		
	Range :	1 ~ 65500		
	Data Size :	16bit		
	Format :	DEC		

Settings : Please refer to P5-20 for the setting of acceleration/deceleration time in PR mode.

P5-32	AC12	Acceleration/Deceleration Time (Number #12)	Address: 0540H 0541H
	Operational Interface :	Panel / Software	Communication
	Default :	5000	
	Control Mode :	PR	
	Unit :	ms	
	Range :	1 ~ 65500	
	Data Size :	16bit	
	Format :	DEC	

Settings : Please refer to P5-20 for the setting of acceleration/deceleration time in PR mode.

P5-33	AC13	Acceleration/Deceleration Time (Number #13)	Address: 0542H 0543H
	Operational Interface :	Panel / Software	Communication
	Default :	8000	
	Control Mode :	PR	
	Unit :	ms	
	Range :	1 ~ 65500	
	Data Size :	16bit	
	Format :	DEC	

Settings : Please refer to P5-20 for the setting of acceleration/deceleration time in PR mode.

P5-34	AC14	Acceleration/Deceleration Time (Number #14)	Address: 0544H 0545H
	Operational Interface :	Panel / Software	Communication
	Default :	50	
	Control Mode :	PR	
	Unit :	ms	
	Range :	1 ~ 65500	
	Data Size :	16bit	

Format :	DEC
----------	-----

Settings : The default value of this parameter is smaller (short deceleration time) and it is used for deceleration time setting of auto protection.

P5-35	AC15	Acceleration/Deceleration Time (Number #15)		Address: 0546H 0547H
	Operational Interface :	Panel / Software	Communication	Related Section: 7.10
	Default :	30		
	Control Mode :	PR		
	Unit :	ms		
	Range :	1 ~ 65500		
	Data Size :	16bit		
	Format :	DEC		

Settings : The default value of this parameter is smaller (short deceleration time) and it is used for short deceleration time and stops promptly of auto protection.

P5-36	CAST	CAPTURE - Start Address of Data Array		Address: 0548H 0549H
	Operational Interface :	Panel / Software	Communication	Related Section: 7.11.1
	Default :	0		
	Control Mode :	ALL		
	Unit :	-		
	Range :	0 ~ (value set by P5-10 minus 1)		
	Data Size :	16bit		
	Format :	DEC		

Settings : The first data CAPTURE obtained should be saved in the address of data array.

Note : It is writable only when COMPARE stops (please refer to P5-39)

P5-37	CAAX	CAPTURE - Axis Position CNT		Address: 054AH 054BH
Operational Interface :	Panel / Software	Communication		Related Section: 7.11.1
Default :	0			
Control Mode :	ALL			
Unit :	-			
Range :	-2147483648 ~ +2147483647			
Data Size :	32bit			
Format :	DEC			

Settings : Shows the axis position of CAPTURE pulse source

Note : 1) It is writable only when COMPARE stops (please refer to P5-39)

2) If the source is the main encoder, this parameter is write-protected and the content is the feedback position of the motor (monitor variable 00h).

P5-38	CANO	CAPTURE - The Number of Capturing Times		Address: 054CH 054DH
Operational Interface :	Panel / Software	Communication		Related Section: 7.11.1
Default :	1			
Control Mode :	ALL			
Unit :	-			
Range :	1 ~ (the value set by P5-10 minus the value set by P5-36)			
Data Size :	16bit			
Format :	DEC			

Settings : When CAP stops, it means the number of data that expect to capture (readable and writable)

When CAP activates, it means the number of data that has not been captured (read-only); Every time, when it captures one data, the value of P5-38 will minus one. When the value is 0, it means the capturing is completed.

Note : The number of data which is used by COMPARE, CAPTURE and E-Cam cannot exceed 800.

P5-39

CACT	CAPTURE - Activate CAP Control		Address: 054EH 054FH
Operational Interface :	Panel / Software	Communication	Related Section: 7.11.1
Default :	0x2010		
Control Mode :	ALL		
Unit :	-		
Range :	0x0000 ~ 0xF13F		
Data Size :	16bit		
Format :	HEX		

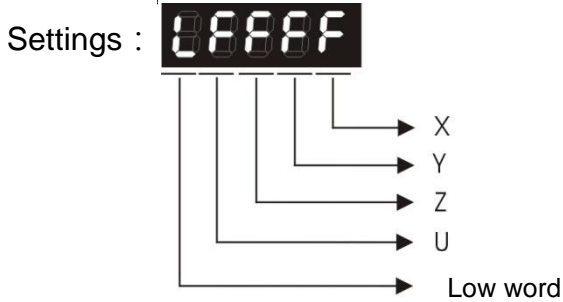

X: See the following table

Y: 0 - CAPTURE is not working

1 - AUX ENC (linear scale) is set as the source

2 - PULSE Cmd

3 - Main ENC (main encoder)

When the source of CMP is CAP axis, the source Y of CAP cannot be changed.

Z: 0 - NO, 1 - NC

U: trigger the minimum interval (Unit: ms)

bit	3	2	1	0
X function	Execute PR when finishing capturing	After capturing the first data, CMP is activated.	Reset the position of the first data	Activate CAP
Description	Execute PR # 50 after finishing CAP	It is invalid when CMP is activated.	After capturing the first data, reset the position coordinate	Starts to capture when it is set to 1. After finishing capturing, this bit becomes 0 automatically.

bit 0: When the value set by P5-38 is bigger than 0, set bit 0 to 1 will activate CAP function and DO.CAP_OK is OFF. Every time, when a data is captured, the value of P5-38 will minus one. When the P5-38 is 0, it means the capture function is completed, DO.CAP_OK is ON and bit 0 will be reset to 0 automatically. If P5-38 equals to 0, set bit 0 to 1 will not activate CAP function. DO.CAP_OK is OFF and bit 0 will automatically be set to 0. If CAP function is activated, it cannot set 1 to bit 0. It only can be written 0 to disable CAP function.

bit 1: If this bit is 1, when capturing the first data, the current position of CAP axis will be set to the value of P5-76.

bit 2: If this bit is 1, when capturing the first data, CMP will be activated. (When bit 0 of P5-59 is set to 1 and P5-58 is set to the previous value.) If CMP has been activated, then this function is invalid.

bit 3: If this bit is 1, as soon as the CAP finished, PR procedure #50 will be triggered automatically.

P5-40	DLY0	Delay Time After Position Completed (Number #0)	Address: 0550H 0551H
Operational Interface :	Panel / Software	Communication	Related Section: 7.10
Default :	0		
Control Mode :	PR		
Unit :	ms		
Range :	0 ~ 32767		
Data Size :	16bit		
Format :	DEC		

Settings : The 1st Delay Time of PR mode

P5-41	DLY1	Delay Time After Position Completed (Number #1)	Address: 0552H 0553H
Operational Interface :	Panel / Software	Communication	Related Section: 7.10
Default :	100		
Control Mode :	PR		
Unit :	ms		
Range :	0 ~ 32767		
Data Size :	16bit		

Format :	DEC
----------	-----

Settings : The 2nd Delay Time of PR mode

P5-42	DLY2	Delay Time After Position Completed (Number #2)		Address: 0554H 0555H
	Operational Interface :	Panel / Software	Communication	Related Section: 7.10
Default :	200			
Control Mode :	PR			
Unit :	ms			
Range :	0 ~ 32767			
Data Size :	16bit			
Format :	DEC			

Settings : The 3rd Delay Time of PR mode

P5-43	DLY3	Delay Time After Position Completed (Number #3)		Address: 0556H 0557H
	Operational Interface :	Panel / Software	Communication	Related Section: 7.10
Default :	400			
Control Mode :	PR			
Unit :	ms			
Range :	0 ~ 32767			
Data Size :	16bit			
Format :	DEC			

Settings : The 4th Delay Time of PR mode

P5-44	DLY4	Delay Time After Position Completed (Number #4)		Address: 0558H 0559H
	Operational Interface :	Panel / Software	Communication	Related Section: 7.10
Default :	500			
Control Mode :	PR			
Unit :	ms			

Range :	0 ~ 32767
Data Size :	16bit
Format :	DEC

Settings : The 5th Delay Time of PR mode

P5-45	DLY5	Delay Time After Position Completed (Number #5)	Address: 055AH 055BH
	Operational Interface :	Panel / Software	Communication
	Default :	800	
	Control Mode :	PR	
	Unit :	ms	
	Range :	0 ~ 32767	
	Data Size :	16bit	
	Format :	DEC	

Settings : The 6th Delay Time of PR mode

P5-46	DLY6	Delay Time After Position Completed (Number #6)	Address: 055CH 055DH
	Operational Interface :	Panel / Software	Communication
	Default :	1000	
	Control Mode :	PR	
	Unit :	ms	
	Range :	0 ~ 32767	
	Data Size :	16bit	
	Format :	DEC	

Settings : The 7th Delay Time of PR mode

P5-47	DLY7 Delay Time After Position Completed (Number #7)		Address: 055EH 055FH
	Operational Interface :	Panel / Software	Communication
Default :	1500		
Control Mode :	PR		
Unit :	ms		
Range :	0 ~ 32767		
Data Size :	16bit		
Format :	DEC		

Settings : The 8th Delay Time of PR mode

P5-48	DLY8 Delay Time After Position Completed (Number #8)		Address: 0560H 0561H
	Operational Interface :	Panel / Software	Communication
Default :	2000		
Control Mode :	PR		
Unit :	ms		
Range :	0 ~ 32767		
Data Size :	16bit		
Format :	DEC		

Settings : The 9th Delay Time of PR mode

P5-49	DLY9 Delay Time After Position Completed (Number #9)		Address: 0562H 0563H
	Operational Interface :	Panel / Software	Communication
Default :	2500		
Control Mode :	PR		
Unit :	ms		
Range :	0 ~ 32767		
Data Size :	16bit		
Format :	DEC		

Settings : The 10th Delay Time of PR mode

P5-50	DLY10	Delay Time After Position Completed (Number #10)		Address: 0564H 0565H
	Operational Interface :	Panel / Software	Communication	Related Section: 7.10
	Default :	3000		
	Control Mode :	PR		
	Unit :	ms		
	Range :	0 ~ 32767		
	Data Size :	16bit		
	Format :	DEC		

Settings : The 11th Delay Time of PR mode

P5-51	DLY11	Delay Time After Position Completed (Number #11)		Address: 0566H 0567H
	Operational Interface :	Panel / Software	Communication	Related Section: 7.10
	Default :	3500		
	Control Mode :	PR		
	Unit :	ms		
	Range :	0 ~ 32767		
	Data Size :	16bit		
	Format :	DEC		

Settings : The 12th Delay Time of PR mode

P5-52	DLY12	Delay Time After Position Completed (Number #12)		Address: 0568H 0569H
	Operational Interface :	Panel / Software	Communication	Related Section: 7.10
	Default :	4000		
	Control Mode :	PR		
	Unit :	ms		
	Range :	0 ~ 32767		

Data Size :	16bit
Format :	DEC

Settings : The 13th Delay Time of PR mode

P5-53	DLY13	Delay Time After Position Completed (Number #13)		Address: 056AH 056BH
	Operational Interface :	Panel / Software	Communication	Related Section: 7.10
	Default :	4500		
	Control Mode :	PR		
	Unit :	ms		
	Range :	0 ~ 32767		
	Data Size :	16bit		
	Format :	DEC		

Settings : The 14th Delay Time of PR mode

P5-54	DLY14	Delay Time After Position Completed (Number #14)		Address: 056CH 056DH
	Operational Interface :	Panel / Software	Communication	Related Section: 7.10
	Default :	5000		
	Control Mode :	PR		
	Unit :	ms		
	Range :	0 ~ 32767		
	Data Size :	16bit		
	Format :	DEC		

Settings : The 15th Delay Time of PR mode

P5-55	DLY15	Delay Time After Position Completed (Number #15)		Address: 056EH 056FH
	Operational Interface :	Panel / Software	Communication	Related Section: 7.10
	Default :	5500		
	Control Mode :	PR		

Unit :	ms
Range :	0 ~ 32767
Data Size :	16bit
Format :	DEC

Settings : The 16th Delay Time of PR mode

P5-56	CMST	COMPARE - Start Address of Data Array	Address: 0570H 0571H
	Operational Interface :	Panel / Software	Communication
	Default :	0	
	Control Mode :	ALL	
	Unit :	-	
	Range :	0 ~ (The value of P5-10 minus 1)	
	Data Size :	16bit	
	Format :	DEC	

Settings : The first COMPARE data is saved in the address of data array.

Note : It is writable only when COMPARE stops (please refer to P5-59)

P5-57	CMAx	COMPARE - Axis Position	Address: 0572H 0573H
	Operational Interface :	Panel / Software	Communication
	Default :	0	
	Control Mode :	ALL	
	Unit :	-	
	Range :	-2147483648 ~ +2147483647	
	Data Size :	32bit	
	Format :	DEC	

Settings : The axis position of COMPARE pulse source is displayed here.
It is writable only when COMPARE stops (please refer to P5-59)

Note : 1) It is write-protected when the source is Capture axis.

2) When the source is the main encoder, P5-57 is also write-protected. The pulse revolution is determined by parameter P1-46. When P5-59.Y is set to the main encoder, this parameter is set to the motor feedback position (monitor variable 00h). If this parameter is not the same as the motor feedback position due to homing or reset by CAP function, the user can set P5-59.Y = 0 and then P5-59.Y = 3. In this way, this parameter will be reset to the motor feedback position.

P5-58	CMNO	COMPARE - Compare Amount	Address: 0574H 0575H
Operational Interface :	Panel / Software	Communication	Related Section: 7.11.2
Default :	1		
Control Mode :	ALL		
Unit :	-		
Range :	1 ~ (the value set by P5-10 minus the value set by P5-56)		
Data Size :	16bit		
Format :	DEC		

Settings : When COMPARE stops, it means the number of data that expect to compare (readable and writable)
When COMPARE activates, it means the number of data that has not been compared (read-only); Every time, when it compares one data, the value of P5-38 will minus one. When the value is 0, it means the comparing is completed.

P5-59	CMCT	COMPARE - Activate CMP Control	Address: 0576H 0577H
Operational Interface :	Panel / Software	Communication	Related Section: 7.11.2
Default :	00640010h		
Control Mode :	ALL		
Unit :	-		
Range :	00010000h ~ 0x0FFF313F		
Data Size :	32bit		
Format :	HEX		

Settings :

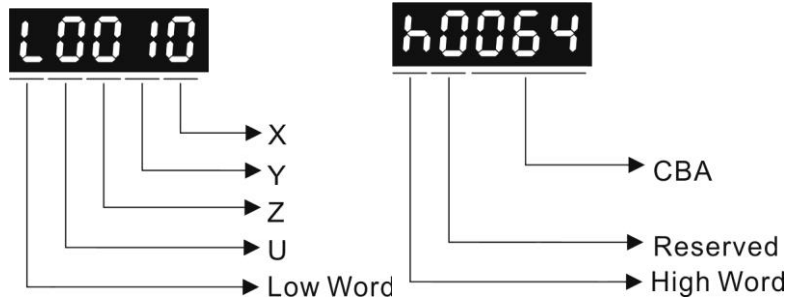

X: See the following table.

Y: 0 - When selecting CAPTURE AXES, the source of CAP cannot be changed.

1 - AUX ENC (linear scale) is set as the source

2 - PULSE Cmd

3 - Main ENC (main encoder)

Z: 0 - NO, 1 - NC outputs the polarity

U: See table U below:

bit	15	14	13	12
U function	-	-	Follow CAP	Trigger PR
Description	-	-	CMPdata is set by CAP It is provided in V1.038 sub19 (or the later version)	When this bit is set, PR#45 will be triggered after the last compare is completed. It is provided in V1.038 sub09 (or the later version)

CBA: Output the pulse length; Unit: 1ms

bit	3	2	1	0
X function	After finishing comparing, the counter returns to 0.	When finishing comparing, CAP is activated.	Cycle mode	CMP is activated
Description	As soon as the last data is compared, P5-57 is set to 0.	It is invalid when CAP is activated.	Never end	Starts to compare when this bit is set to 1. It returns to 0 when finishing comparing.

- bit 0: When the value of P5-58 is more than 0, set bit to 1 will activate CMP. When comparing one data, the value of P5-58 will minus 1. When P5-58 is set to 0, the comparing is completed and returns to 0. If P5-58 is 0, set bit 0 to 1 will not do any comparing and return to 0 automatically. If bit 0 has already been set to 1, it is not allowed to write 1 as the new value into the parameter. But it is ok to write 0 to disable CMP.
- bit 1: If this bit is 1, P5-58 will be reset after comparing the last data. Then, start from the first data again. The cycle will never end and bit 0 is always 1.
- bit 2: If this bit is 1, CAP will be activated after comparing the last data. (Set bit 0 of P5-39 to 1 and reset P5-38 to the previous value) If CAP has already been activated, this function is invalid.
- bit 3: If this bit is 1, set the counter (P5-57) to 0 after comparing the last data. For example, if the comparing data is set to 3000 (one data in total), the default value of the counter (P5-57) is 0. It is expected to input 4000 pulse. When it reaches the 3000th pulse, the CMP is completed and P5-57 returns to 0. When the pulse reaches 4000, P5-57=1000. (No accumulative error)

P5-60	POV0	Target Speed Setting #0		Address: 0578H 0579H
Operational Interface :	Panel / Software	Communication		Related Section: 7.10
Default :	20.0	200		
Control Mode :	PR			
Unit :	1 r/min	0.1 r/min		
Range :	0.1 ~ 6000.0	1 ~ 60000		
Data Size :	16bit			
Format :	DEC			
Example :	15 = 15 r/min	150 = 15 r/min		

Settings : The 1st target speed of PR mode

P5-61	POV1	Target Speed Setting #1		Address: 057AH 057BH
Operational Interface :	Panel / Software	Communication		Related Section: 7.10
Default :	50.0	500		

Control Mode :	PR	
Unit :	Permanet magnet synchronous rotary motor: 1rpm Permanet magnet synchronous linear motor: 10 ⁻⁶ m/s	Permanet magnet synchronous rotary motor: 0.1rpm Permanet magnet synchronous linear motor: 10 ⁻⁶ m/s
Range :	Permanet magnet synchronous rotary motor: 0.1 ~ 6000.0 Permanet magnet synchronous linear motor: 1~15999999	Permanet magnet synchronous rotary motor: 1 ~ 60000 Permanet magnet synchronous linear motor: 1~15999999
Data Size :	32bit	
Format :	DEC	
Example :	Permanet magnet synchronous rotary motor: 1= 1 r/min Permanet magnet synchronous linear motor: 1000.0 = 0.01m/s	Permanet magnet synchronous rotary motor: 10 = 1r/min Permanet magnet synchronous linear motor: 10000 = 0.01m/s

Settings : The 2nd target speed of PR mode

P5-62	POV2	Target Speed Setting #2		Address: 057CH 057DH
	Operational Interface :	Panel / Software	Communication	Related Section: 7.10
	Default :	100.0	1000	
	Control Mode :	PR		
	Unit :	Permanet magnet synchronous rotary motor: 1rpm Permanet magnet synchronous linear motor: 10 ⁻⁶ m/s	Permanet magnet synchronous rotary motor: 0.1rpm Permanet magnet synchronous linear motor: 10 ⁻⁶ m/s	
	Range :	Permanet magnet synchronous rotary motor: 0.1 ~ 6000.0 Permanet magnet synchronous linear motor: 1~15999999	Permanet magnet synchronous rotary motor: 1 ~ 60000 Permanet magnet synchronous linear motor: 1~15999999	
	Data Size :	32bit		

Format :	DEC	
Example :	Permant magnet synchronous rotary motor: 1= 1 r/min Permant magnet synchronous linear motor: 1000.0 = 0.01m/s	Permant magnet synchronous rotary motor: 10 = 1r/min Permant magnet synchronous linear motor: 10000 = 0.01m/s

Settings : The 3rd target speed of PR mode

P5-63	POV3	Target Speed Setting #3		Address: 057EH 057FH
	Operational Interface :	Panel / Software	Communication	Related Section: 7.10
	Default :	200.0	2000	
	Control Mode :	PR		
	Unit :	Permant magnet synchronous rotary motor: 1rpm Permant magnet synchronous linear motor: 10 ⁻⁶ m/s	Permant magnet synchronous rotary motor: 0.1rpm Permant magnet synchronous linear motor: 10 ⁻⁶ m/s	
	Range :	Permant magnet synchronous rotary motor: 0.1 ~ 6000.0 Permant magnet synchronous linear motor: 1~15999999	Permant magnet synchronous rotary motor: 1 ~ 60000 Permant magnet synchronous linear motor: 1~15999999	
	Data Size :	32bit		
	Format :	DEC		
	Example :	Permant magnet synchronous rotary motor: 1= 1 r/min Permant magnet synchronous linear motor: 1000.0 = 0.01m/s	Permant magnet synchronous rotary motor: 10 = 1r/min Permant magnet synchronous linear motor: 10000 = 0.01m/s	

Settings : The 4th target speed of PR mode

P5-64	POV4	Target Speed Setting #4		Address: 0580H 0581H
Operational Interface :	Panel / Software	Communication	Related Section: 7.10	
Default :	300.0	3000		
Control Mode :	PR			
Unit :	Permanet magnet synchronous rotary motor: 1rpm Permanet magnet synchronous linear motor: 10 ⁻⁶ m/s	Permanet magnet synchronous rotary motor: 0.1rpm Permanet magnet synchronous linear motor: 10 ⁻⁶ m/s		
Range :	Permanet magnet synchronous rotary motor: 0.1 ~ 6000.0 Permanet magnet synchronous linear motor: 1~15999999	Permanet magnet synchronous rotary motor: 1 ~ 60000 Permanet magnet synchronous linear motor: 1~15999999		
Data Size :	32bit			
Format :	DEC			
Example :	Permanet magnet synchronous rotary motor: 1= 1 r/min Permanet magnet synchronous linear motor: 1000.0 = 0.01m/s	Permanet magnet synchronous rotary motor: 10 = 1r/min Permanet magnet synchronous linear motor: 10000 = 0.01m/s		

Settings : The 5th target speed of PR mode

P5-65	POV5	Target Speed Setting #5		Address: 0582H 0583H
Operational Interface :	Panel / Software	Communication	Related Section: 7.10	
Default :	500.0	5000		
Control Mode :	PR			
Unit :	Permanet magnet synchronous rotary motor: 1rpm Permanet magnet synchronous linear motor: 10 ⁻⁶ m/s	Permanet magnet synchronous rotary motor: 0.1rpm Permanet magnet synchronous linear motor: 10 ⁻⁶ m/s		

Range :	Permanet magnet synchronous rotary motor: 0.1 ~ 6000.0 Permanet magnet synchronous linear motor: 1~15999999	Permanet magnet synchronous rotary motor: 1 ~ 60000 Permanet magnet synchronous linear motor: 1~15999999
Data Size :	32bit	
Format :	DEC	
Example :	Permanet magnet synchronous rotary motor: 1= 1 r/min Permanet magnet synchronous linear motor: 1000.0 = 0.01m/s	Permanet magnet synchronous rotary motor: 10 = 1r/min Permanet magnet synchronous linear motor: 10000 = 0.01m/s

Settings : The 6th target speed of PR mode

P5-66	POV6	Target Speed Setting #6		Address: 0584H 0585H
	Operational Interface :	Panel / Software	Communication	Related Section: 7.10
	Default :	600.0	6000	
	Control Mode :	PR		
	Unit :	Permanet magnet synchronous rotary motor: 1rpm Permanet magnet synchronous linear motor: 10 ⁻⁶ m/s	Permanet magnet synchronous rotary motor: 0.1rpm Permanet magnet synchronous linear motor: 10 ⁻⁶ m/s	
	Range :	Permanet magnet synchronous rotary motor: 0.1 ~ 6000.0 Permanet magnet synchronous linear motor: 1~15999999	Permanet magnet synchronous rotary motor: 1 ~ 60000 Permanet magnet synchronous linear motor: 1~15999999	
	Data Size :	32bit		
	Format :	DEC		

Example :	Permanet magnet synchronous rotary motor: 1= 1 r/min Permanet magnet synchronous linear motor: 1000.0 = 0.01m/s	Permanet magnet synchronous rotary motor: 10 = 1r/min Permanet magnet synchronous linear motor: 10000 = 0.01m/s
-----------	--	--

Settings : The 7th target speed of PR mode

P5-67	POV7	Target Speed Setting #7		Address: 0586H 0587H
	Operational Interface :	Panel / Software	Communication	Related Section: 7.10
	Default :	800.0	8000	
	Control Mode :	PR		
	Unit :	Permanet magnet synchronous rotary motor: 1rpm Permanet magnet synchronous linear motor: 10 ⁻⁶ m/s	Permanet magnet synchronous rotary motor: 0.1rpm Permanet magnet synchronous linear motor: 10 ⁻⁶ m/s	
	Range :	Permanet magnet synchronous rotary motor: 0.1 ~ 6000.0 Permanet magnet synchronous linear motor: 1~15999999	Permanet magnet synchronous rotary motor: 1 ~ 60000 Permanet magnet synchronous linear motor: 1~15999999	
	Data Size :	32bit		
	Format :	DEC		
	Example :	Permanet magnet synchronous rotary motor: 1= 1 r/min Permanet magnet synchronous linear motor: 1000.0 = 0.01m/s	Permanet magnet synchronous rotary motor: 10 = 1r/min Permanet magnet synchronous linear motor: 10000 = 0.01m/s	

Settings : The 8th target speed of PR mode

P5-68

POV8	Target Speed Setting #8		Address: 0588H 0589H
Operational Interface :	Panel / Software	Communication	Related Section: 7.10
Default :	1000.0	10000	
Control Mode :	PR		
Unit :	Permanet magnet synchronous rotary motor: 1rpm Permanet magnet synchronous linear motor: 10^{-6} m/s	Permanet magnet synchronous rotary motor: 0.1rpm Permanet magnet synchronous linear motor: 10^{-6} m/s	
Range :	Permanet magnet synchronous rotary motor: 0.1 ~ 6000.0 Permanet magnet synchronous linear motor: 1~15999999	Permanet magnet synchronous rotary motor: 1 ~ 60000 Permanet magnet synchronous linear motor: 1~15999999	
Data Size :	32bit		
Format :	DEC		
Example :	Permanet magnet synchronous rotary motor: 1= 1 r/min Permanet magnet synchronous linear motor: 1000.0 = 0.01m/s	Permanet magnet synchronous rotary motor: 10 = 1r/min Permanet magnet synchronous linear motor: 10000 = 0.01m/s	

Settings : The 9th target speed of PR mode

P5-69	POV9	Target Speed Setting #9		Address: 058AH 058BH
	Operational Interface :	Panel / Software	Communication	
Default :	1300.0	13000		
Control Mode :	PR			
Unit :	Permanet magnet synchronous rotary motor: 1rpm Permanet magnet synchronous linear motor: 10 ⁻⁶ m/s	Permanet magnet synchronous rotary motor: 0.1rpm Permanet magnet synchronous linear motor: 10 ⁻⁶ m/s		
Range :	Permanet magnet synchronous rotary motor: 0.1 ~ 6000.0 Permanet magnet synchronous linear motor: 1~15999999	Permanet magnet synchronous rotary motor: 1 ~ 60000 Permanet magnet synchronous linear motor: 1~15999999		
Data Size :	32bit			
Format :	DEC			
Example :	Permanet magnet synchronous rotary motor: 1= 1 r/min Permanet magnet synchronous linear motor: 1000.0 = 0.01m/s	Permanet magnet synchronous rotary motor: 10 = 1r/min Permanet magnet synchronous linear motor: 10000 = 0.01m/s		

Settings : The 10th target speed of PR mode

P5-70	POV10	Target Speed Setting #10		Address: 058CH 058DH
	Operational Interface :	Panel / Software	Communication	
Default :	1500.0	15000		
Control Mode :	PR			
Unit :	Permanet magnet synchronous rotary motor: 1rpm Permanet magnet synchronous linear motor: 10 ⁻⁶ m/s	Permanet magnet synchronous rotary motor: 0.1rpm Permanet magnet synchronous linear motor: 10 ⁻⁶ m/s		

Range :	Permanet magnet synchronous rotary motor: 0.1 ~ 6000.0 Permanet magnet synchronous linear motor: 1~15999999	Permanet magnet synchronous rotary motor: 1 ~ 60000 Permanet magnet synchronous linear motor: 1~15999999
Data Size :	32bit	
Format :	DEC	
Example :	Permanet magnet synchronous rotary motor: 1= 1 r/min Permanet magnet synchronous linear motor: 1000.0 = 0.01m/s	Permanet magnet synchronous rotary motor: 10 = 1r/min Permanet magnet synchronous linear motor: 10000 = 0.01m/s

Settings : The 11th target speed of PR mode

P5-71	POV11	Target Speed Setting #11		Address: 058EH 058FH
	Operational Interface :	Panel / Software	Communication	Related Section: 7.10
	Default :	1800.0	18000	
	Control Mode :	PR		
	Unit :	Permanet magnet synchronous rotary motor: 1rpm Permanet magnet synchronous linear motor: 10 ⁻⁶ m/s	Permanet magnet synchronous rotary motor: 0.1rpm Permanet magnet synchronous linear motor: 10 ⁻⁶ m/s	
	Range :	Permanet magnet synchronous rotary motor: 0.1 ~ 6000.0 Permanet magnet synchronous linear motor: 1~15999999	Permanet magnet synchronous rotary motor: 1 ~ 60000 Permanet magnet synchronous linear motor: 1~15999999	
	Data Size :	32bit		
	Format :	DEC		

Example :	Permanet magnet synchronous rotary motor: 1= 1 r/min Permanet magnet synchronous linear motor: 1000.0 = 0.01m/s	Permanet magnet synchronous rotary motor: 10 = 1r/min Permanet magnet synchronous linear motor: 10000 = 0.01m/s
-----------	--	--

Settings : The 12th target speed of PR mode

P5-72	POV12	Target Speed Setting #12		Address: 0590H 0591H
	Operational Interface :	Panel / Software	Communication	Related Section: 7.10
	Default :	2000.0	20000	
	Control Mode :	PR		
	Unit :	Permanet magnet synchronous rotary motor: 1rpm Permanet magnet synchronous linear motor: 10 ⁻⁶ m/s	Permanet magnet synchronous rotary motor: 0.1rpm Permanet magnet synchronous linear motor: 10 ⁻⁶ m/s	
	Range :	Permanet magnet synchronous rotary motor: 0.1 ~ 6000.0 Permanet magnet synchronous linear motor: 1~15999999	Permanet magnet synchronous rotary motor: 1 ~ 60000 Permanet magnet synchronous linear motor: 1~15999999	
	Data Size :	32bit		
	Format :	DEC		
	Example :	Permanet magnet synchronous rotary motor: 1= 1 r/min Permanet magnet synchronous linear motor: 1000.0 = 0.01m/s	Permanet magnet synchronous rotary motor: 10 = 1r/min Permanet magnet synchronous linear motor: 10000 = 0.01m/s	

Settings : The 13th target speed of PR mode

P5-73	POV13	Target Speed Setting #13		Address: 0592H 0593H
Operational Interface :	Panel / Software	Communication		Related Section: 7.10
Default :	2300.0	23000		
Control Mode :	PR			
Unit :	Permanet magnet synchronous rotary motor: 1rpm Permanet magnet synchronous linear motor: 10^{-6} m/s	Permanet magnet synchronous rotary motor: 0.1rpm Permanet magnet synchronous linear motor: 10^{-6} m/s		
Range :	Permanet magnet synchronous rotary motor: 0.1 ~ 6000.0 Permanet magnet synchronous linear motor: 1~15999999	Permanet magnet synchronous rotary motor: 1 ~ 60000 Permanet magnet synchronous linear motor: 1~15999999		
Data Size :	32bit			
Format :	DEC			
Example :	Permanet magnet synchronous rotary motor: 1= 1 r/min Permanet magnet synchronous linear motor: 1000.0 = 0.01m/s	Permanet magnet synchronous rotary motor: 10 = 1r/min Permanet magnet synchronous linear motor: 10000 = 0.01m/s		

Settings : The 14th target speed of PR mode

P5-74	POV14	Target Speed Setting #14		Address: 0594H 0595H
Operational Interface :	Panel / Software	Communication	Related Section: 7.10	
Default :	2500.0	25000		
Control Mode :	PR			
Unit :	Permanet magnet synchronous rotary motor: 1rpm Permanet magnet synchronous linear motor: 10 ⁻⁶ m/s	Permanet magnet synchronous rotary motor: 0.1rpm Permanet magnet synchronous linear motor: 10 ⁻⁶ m/s		
Range :	Permanet magnet synchronous rotary motor: 0.1 ~ 6000.0 Permanet magnet synchronous linear motor: 1~15999999	Permanet magnet synchronous rotary motor: 1 ~ 60000 Permanet magnet synchronous linear motor: 1~15999999		
Data Size :	32bit			
Format :	DEC			
Example :	Permanet magnet synchronous rotary motor: 1= 1 r/min Permanet magnet synchronous linear motor: 1000.0 = 0.01m/s	Permanet magnet synchronous rotary motor: 10 = 1r/min Permanet magnet synchronous linear motor: 10000 = 0.01m/s		

Settings : The 15th target speed of PR mode

P5-75	POV15	Target Speed Setting #15		Address: 0596H 0597H
Operational Interface :	Panel / Software	Communication	Related Section: 7.10	
Default :	3000.0	30000		
Control Mode :	PR			
Unit :	Permanet magnet synchronous rotary motor: 1rpm Permanet magnet synchronous linear motor: 10 ⁻⁶ m/s	Permanet magnet synchronous rotary motor: 0.1rpm Permanet magnet synchronous linear motor: 10 ⁻⁶ m/s		
Range :	Permanet magnet synchronous rotary motor: 0.1 ~ 6000.0 Permanet magnet synchronous linear motor: 1~15999999	Permanet magnet synchronous rotary motor: 1 ~ 60000 Permanet magnet synchronous linear motor: 1~15999999		
Data Size :	32bit			
Format :	DEC			
Example :	Permanet magnet synchronous rotary motor: 1= 1 r/min Permanet magnet synchronous linear motor: 1000.0 = 0.01m/s	Permanet magnet synchronous rotary motor: 10 = 1r/min Permanet magnet synchronous linear motor: 10000 = 0.01m/s		

Settings : The 16th target speed of PR mode

P5-76★	CPRS	CAPTURE - First Position Reset Data		Address: 0598H 0599H
Operational Interface :	Panel / Software	Communication	Related Section: 7.10	
Default :	0			
Control Mode :	ALL			
Unit :	-			
Range :	-1073741824 ~ +1073741823			
Data Size :	32bit			
Format :	DEC			

Settings : Please refer to the description of P5-39 X 1

P5-77	CSAX	The Position of Synchronous Capture Axis (CAP SYNC AXES)		Address: 059AH 059BH
	Operational Interface :	Panel / Software	Communication	Related Section: -
	Default :	0		
	Control Mode :	ALL		
	Unit :	-		
	Range :	-2147483648 ~ +2147483647		
	Data Size :	32bit		
	Format :	DEC		

Settings : The position of this axis will synchronize with CAP signal. That is to say, when activating CAP every two times, the motor moving distance of this axis is the value of P5-78. (There is no accumulative error and only in single-way operation) The synchronous capture axis can be the source of Master.

P5-78	CSDS	The Interval Pulse Number between Each Synchronous Capture Axis		Address: 059CH 059DH
	Operational Interface :	Panel / Software	Communication	Related Section: -
	Default :	100		
	Control Mode :	ALL		
	Unit :	Pulse		
	Range :	10 ~ +100000000		
	Data Size :	32bit		
	Format :	DEC		

Settings : It is the moving distance of synchronous capture axis between two CAP actions.
The new value can be written into the parameter not until CAP is disabled (P5-39, X0=0).

P5-79

CSDS	Error Pulse Number of Synchronous Capture Axis		Address: 059EH 059FH
Operational Interface :	Panel / Software	Communication	Related Section: -
Default :	0		
Control Mode :	ALL		
Unit :	Pulse unit of capture axis		
Range :	-2147483648 ~ +2147483647		
Data Size :	32bit		
Format :	DEC		

Settings : When synchronous capture axis is operating, the synchronous error should be 0. This parameter shows this error value. The followings are its concept:

$$\begin{aligned} \text{Synchronous Error} &= \text{Output value of synchronous axis} - \\ &\quad \text{Setting value of synchronous axis} \\ &= \text{the accumulative amount of P5-77} - \\ &\quad (\text{P5-78} \times \text{Capturing number of times}) \end{aligned}$$

When capturing the data, the synchronous axis works normally. This parameter updates once.

This parameter can be written into as well. It indicates the offset of synchronous master. When the synchronous capture axis is regarded as the master of flying shear, modify this parameter can deviate the cutting position to the left/right.

P5-80

CSDS	Max. Correction Rate of Synchronous Capture Axis		Address: 05A0H 05A1H
Operational Interface :	Panel / Software	Communication	Related Section: -
Default :	10		
Control Mode :	ALL		
Unit :	%		
Range :	0 ~ 90		
Data Size :	16bit		
Format :	DEC		

Settings : This parameter limits the percentage (%) of synchronous adjustment.

Correction rate

$$= \frac{\text{pulse number output by synchronous axis}}{\text{pulse number input by synchronous axis}} (100 - P5 - 80)\%$$

$$< \text{correctionrate} < (100 + P5 - 80)\%$$

The bigger correction rate, the faster the synchronous error becomes 0. However, the speed changing will be more severe.

The smaller correction rate, the slower the synchronous error becomes 0. However, the speed changing will be more smooth.

In the application of flying shear, after adjusting the synchronous error, P5-79: the bigger parameter value will reduce the time the slave axis goes to the desired position. However, the speed is not synchronized.

P5-81	ECHD	E-CAM: Start Address of Data Array		Address: 05A2H 05A3H
	Operational Interface :	Panel / Software	Communication	Related Section: 7.11
	Default :	100		
	Control Mode :	PR		
	Unit :	-		
	Range :	0 ~ (800 - P5-82)		
	Data Size :	16bit		
	Format :	DEC		

Settings : The first data of E-Cam table is saved in the address of data array.

Note : This parameter can be set anytime, but will be effective only when pre-engaged → engaged.

P5-82	ECMN	E-CAM: Area Number N (at least ≥ 5)	Address: 05A4H 05A5H
Operational Interface :	Panel / Software	Communication	Related Section: 7.11
Default :	5		
Control Mode :	PR		
Unit :	-		
Range :	5 ~ 720, must \leq (P5-10 - P5-81) And P5-82 x P5-84 \leq 2147483647		
Data Size :	16bit		
Format :	DEC		
Settings :	It means the E-Cam curve is divided into N area, and the table should include N+1 data.		
Note :	This parameter can be wrote when E-Cam stops (Please refer to P5-88, X=0).		

P5-83	ECMM	E-CAM: Master Gear Ratio Setting M	Address: 05A6H 05A7H
Operational Interface :	Panel / Software	Communication	Related Section: 7.11
Default :	1		
Control Mode :	PR		
Unit :	-		
Range :	1 ~ 32767		
Data Size :	16bit		
Format :	DEC		
Settings :	When receiving pulse number P of the Master, E-Cam will rotate M circle, which means the M cycle of the E-Cam table.		
Note :	This parameter can be wrote when E-Cam stops (Please refer to P5-88, X=0).		

P5-84	ECMP	E-CAM: Master Gear Ratio Setting P	Address: 05A8H 05A9H
Operational Interface :	Panel / Software	Communication	Related Section: 7.11
Default :	3600		
Control Mode :	PR		
Unit :	-		
Range :	10 ~ 1073741823, and P5-82 x P5-83 < = P5-84 and P5-82 x P5-84 < = 2147483647		
Data Size :	32bit		
Format :	DEC		

Settings : When receiving pulse number P of the Master, E-Cam will rotate M circle, which means the M cycle of the E-Cam table.

Note : This parameter can be wrote when E-Cam stops (Please refer to P5-88, X=0).

This parameter can be modified anytime, and has no limit that mentioned above.

P5-85	ECME	E-CAM: Number of Area	Address: 05AAH 05ABH
Operational Interface :	Panel / Software	Communication	Related Section: 7.11
Default :	0		
Control Mode :	PR		
Unit :	-		
Range :	0 ~ (P5-82 - 1)		
Data Size :	16bit		
Format :	DEC		

Settings : The area number of E-cam when E-cam engaged.

P5-86

ECAX	E-CAM: Master Axis Position		Address: 05ACH 05ADH
Operational Interface :	Panel / Software	Communication	Related Section: 7.11
Default :	0		
Control Mode :	PR		
Unit :	-		
Range :	-2147483648 ~ +2147483647		
Data Size :	32bit		
Format :	DEC		
Settings :	The position counter of the E-Cam Master		

Note : This parameter can be wrote when E-Cam stops (Please refer to P5-88, X=0).

P5-87

PLED	E-CAM: Lead Pulse		Address: 05AEH 05AFH
Operational Interface :	Panel / Software	Communication	Related Section: 7.11
Default :	0		
Control Mode :	PR		
Unit :	-		
Range :	-1073741824 ~ +1073741823		
Data Size :	32bit		
Format :	DEC		
Settings :	When the engaging condition (P5-88.Z) of E-cam is satisfied, the pulse number from the master has to exceed the setting value of this parameter, so that E-cam is fully engaged.		

In other words, E-cam engages after neglecting the lead pulse specified by this parameter.

If the symbol of this parameter is + , it means the received forward pulse is regarded as the lead pulse.

If the symbol of this parameter is - , it means the received reverse pulse is regarded as the lead pulse.

P5-88	ECON	E-CAM: Activate E-Cam Control		Address: 05B0H 05B1H
	Operational Interface :	Panel / Software	Communication	Related Section: 7.11
	Default :	00000000h		
	Control Mode :	PR		
	Unit :	-		
	Range :	0 ~ 0x203FF251		
	Data Size :	32bit		
	Format :	HEX		

Settings : The format of this parameter: (High word h) S0BA : (Low word L) UZ YX

Definition of each column is as follows:

- X: E-Cam command

Description of each bit:

X3	-	-
X2	P5-19 is effective immediately	It is available after V1.038 sub48: 0: P5-19 is effective after the next engage. 1: P5-19 is effective immediately.
X1	E-Cam does not disengage when Servo OFF	It is available after 1.038 sub29: 0: E-Cam does not work 1: When E-Cam stops because of alarm or Servo Off, it can keep in engaged status. When re-servo on, E-cam can operate directly. It can return to the correct position by macro #D.
X0	E-Cam is enabled	0: E-Cam is disabled 1: E-Cam is enabled (E-CAM is enabled while other functions cannot be modified.)

- Y: Command source
 - 0: CAP axis
 - 1: AUX ENC
 - 2: Pulse Cmd
 - 3: PR command
 - 4: Time Axis (1ms)
 - 5: Synchronous Capture Axis (P5-77)
 - 6: Analog channel 1 (virtual axis, Unit: 1M pulse/s /10V)

- Z: Engaging Time (No multiple choice)
 - 0: Immediately
 - 1: DI.CAM ON
 - 2: Any one of the Capture
- U: Disengaging Condition (2, 4 and 6 cannot be selected at the same time)

U	Disengaged Condition	Action after disengaged
0	Never disengaged	-
1	DI.CAM is OFF	In STOP status
2	Master axis receives the pulse number which is set by P5-89 and stops immediately. (The symbol represents the direction)	In STOP status
6	(It is available after firmware version V1.009) Same as 2, the E-cam starts to decelerate when disengaging. It is suitable for the application of calling the next PR position command right after disengaged.	
4	(It is available after firmware version V1.009) Master axis exceeds the setting value of P5-89 (Sign indicates the direction)	Back to the pre-engage status The lead pulse is P5-92
8	When U = 1, 2 or 6: Disable E-Cam after it is disengaged.	Set X to 0
	When U = 4: To avoid jittering when it returns to lead status.	N/A

Note : The servo is Off, when ALM or forward/reverse limit occur or PR is doing homing procedure, it disengages (P5-88, X = 0)

- BA: When disengaging condition is satisfied (P5-88, U = 2, 4, 6), a PR 00~63 (hexadecimal; 00 means no action) will automatically be executed.
- S: Shows the engage status (Read-only, the setting is invalid)
 - 0: Stop
 - 1: Engage status
 - 2: Pre-engage status

P5-89	ECRD	E-CAM: Information of Disengaging Time		Address: 05B2H 05B3H
	Operational Interface :	Panel / Software	Communication	Related Section: 7.11
	Default :	0		
	Control Mode :	PR		
	Unit :	-		
	Range :	-1073741824 ~ +1073741823		
	Data Size :	32bit		
	Format :	DEC		

Settings : (Please refer to the definition of P5-88 U setting value 2)

P5-90	CMAF	E-CAM: AREA No. + The Point of DO ON		Address: 05B4H 05B5H
	Operational Interface :	Panel / Software	Communication	Related Section: 7.11
	Default :	0		
	Control Mode :	PR		
	Unit :	Angle (It was changed after firmware V1.009)		
	Range :	0 ~ 360		
	Data Size :	16bit		
	Format :	DEC		

Settings : When E-cam is engaged, set the start angle of DO output (DO. CAM_AREA).

P5-91	CMAN	E-CAM: AREA No. - The Point of DO OFF	Address: 05B6H 05B7H
Operational Interface :	Panel / Software	Communication	Related Section: 7.11
Default :	0		
Control Mode :	PR		
Unit :	Angle		
Range :	0 ~ 360		
Data Size :	16bit		
Format :	DEC		

Settings : When E-cam is engaged, set the end angle of DO output (DO. CAM_AREA).

P5-92	PLED	E-CAM: Pre-engaged Time of Each Cycle	Address: 05B8H 05B9H
Operational Interface :	Panel / Software	Communication	Related Section: 7.11
Default :	0		
Control Mode :	PR		
Unit :	-		
Range :	-100000000 ~ +100000000		
Data Size :	32bit		
Format :	DEC		

Settings : This parameter goes with the selection of P5-88, U=4 (E-cam will disengage if it exceeds the moving distance):

After disengaging, it does not enter the Stop status but pre-engaged status. The lead pulse is determined by this parameter.

The pulse number sent by the Master must exceed the setting value of this parameter so that E-cam will engage again.

In other words, E-cam will engage not until the lead pulse is ignored.

If the symbol of this parameter is + , it means the received positive pulse will be regarded as the lead pulse.

If the symbol of this parameter is - , it means the received negative pulse will be regarded as the lead pulse.

P5-93	CSDS	Motion Control Macro Command: Command Parameter # 4	Address: 05BAH 05BBH
Operational Interface :	Panel / Software	Communication	Related Section: -
Default :	0		
Control Mode :	ALL		
Unit :	-		
Range :	-2147483648 ~ +2147483647		
Data Size :	32bit		
Format :	DEC		

Settings : Before issuing the macro command, the relevant parameters # 4 must be set in advance.

The function of the parameter is determined by the macro command. Not every macro command has its relevant parameters.

P5-94	CSDS	Motion Control Macro Command: Command Parameter # 3	Address: 05BCH 05BDH
Operational Interface :	Panel / Software	Communication	Related Section: -
Default :	0		
Control Mode :	ALL		
Unit :	-		
Range :	-2147483648 ~ +2147483647		
Data Size :	32bit		
Format :	DEC		

Settings : Before issuing the macro command, the relevant parameters # 3 must be set in advance.

The function of the parameter is determined by the macro command. Not every macro command has its relevant parameters.

P5-95

CSDS	Motion Control Macro Command: Command Parameter # 2		Address: 05BEH 05BFH
Operational Interface :	Panel / Software	Communication	Related Section: -
Default :	0		
Control Mode :	ALL		
Unit :	-		
Range :	-2147483648 ~ +2147483647		
Data Size :	32bit		
Format :	DEC		

Settings : Before issuing the macro command, the relevant parameters # 2 must be set in advance.

The function of the parameter is determined by the macro command. Not every macro command has its relevant parameters.

P5-96

CSDS	Motion Control Macro Command: Command Parameter # 1		Address: 05C0H 05C1H
Operational Interface :	Panel / Software	Communication	Related Section: -
Default :	0		
Control Mode :	ALL		
Unit :	-		
Range :	-2147483648 ~ +2147483647		
Data Size :	32bit		
Format :	DEC		

Settings : Before issuing the macro command, the relevant parameters # 1 must be set in advance.

The function of the parameter is determined by the macro command. Not every macro command has its relevant parameters.

P5-97	CSDS	Motion Control Macro Command: Issue Command / Executing Result		Address: 05C2H 05C3H
	Operational Interface :	Panel / Software	Communication	Related Section: -
	Default :	100		
	Control Mode :	ALL		
	Unit :	Pulse		
	Range :	0 ~ 0x0999		
	Data Size :	16 bit		
	Format :	HEX		

Settings : Write-in: It is used to issue the macro command (0CBAh)
 Read: It is used to examine the execution result of macro command (If success, the result will be sent back to 1CBAh).

If the command issues 0001, 1001h will be sent back when success; and Fxxh when failed (depending on the command description).

If issuing the command that is not supported, the failure code F001h will be sent back.

The provided command code is as the followings.

Command code 0003h	Motion parameter protection: password setting, protection activation
Macro parameters	P5-94= Protection level of data array (0~7) P5-95= Set new password (1~16777215) P5-96= Confirm new password (1~16777215) Among them: For success setting, the setting of P5-95 must equal to P5-96 and the password must be set within the allowable range.
This function can be executed before activating the function of parameter protection. If the protection function is activated, when repeatedly execute this function, the failure code will be sent back.	
Failure code F031h	Protection function has been activated and cannot be set repeatedly.
Failure code F032h	Wrong password setting: P5-95 not equals to P5-96.
Failure code	Password setting exceeds the allowable range

F033h	(1~16777215).
Failure code F034h	The protection level, P5-94 exceeds the allowable range (0~7).
Success code 1003h	

Command code 0004h	Motion parameter protection: unlock the protection
Macro parameters	P5-96= enter the password (1~16777215)

This function can be executed when activating the function of parameter protection.

If the protection function is unlocked, repeatedly execute this function will sent back the failure code.

If entering the wrong password, failure code Ennn will be sent back. nnn means the rest decode number. It will be minused one number after one failure. When the number is 0, it will be locked for good.

Failure code F041h	Protection function is unlocked and it cannot repeatedly unlock.
Failure code F043h	The password setting exceed the allowable range (1~16777215)
Failure code F044h	The number of times of entering wrong password exceeds the limit: Lock for good. Reset the parameter (P2-08=10) to unlock it is the only method. However, all parameter will return to the default value.
Failure code Ennnh	Incorrect password setting: Failed to unlock. nnn: the rest decode number. It will be minused one number after one failure. When the number is 0, it will be locked for good.
Success code 1004h	

Command code 0006h	Build up E-Cam table: flying shear, including synchronous area (7 areas)
General parameters	P5-81= Address of table (Data array) P5-82 = 7 (This macro is fixed to 7 areas) P1-44, P1-45 = E-gear ratio (it has to be setup in advance)
Macro parameters	P5-94 = A (Deceleration ratio: numerator) x C (Number of cutter) P5-95= B (Deceleration ratio: denominator) P5-96= 1000000 x R x V Among them: R (cutting ratio) = L (cutting length) / ϕ (Girth of cutter) Allowable cutting ratio: (0.3 ~ 2.5) times V (Speed factor) = target cutting speed / speed of delivered product V=1.0: When cutting, the speed of cutter is the same as the product V=1.1: When cutting, the speed of cutter is 10% faster than the product V=0.9: When cutting, the speed of cutter is 10% slower than the product
<p>This macro will calculate the data of E-Cam table according to the above mentioned parameters, and store in data array which designated by P5-81. Parameters listed above are related to E-Cam table calculation. Please correctly setup those parameters before executing this macro.</p> <p>After this macro is executed, if the above parameters has been changed, it has to recreate the E-Cam table and this macro will have to be executed again. Data in E-Cam table will be changed after executing this macro, thus, do not execute it when E-Cam is in engaged status.</p> <p>In E-Cam application, parameters, such as P5-83 and P5-84 that are not related to this macro are not listed here. Users could setup parameters according to the real application. Please refer to Chapter 7, sections about E-Cam.</p> <p>After executing this macro, E-Cam table will not be saved to EEPROM automatically.</p>	
Failure code F061h	When creating the table, E-Cam is in engaged status.
Failure code F062h	The setting value of P5-94 exceeds the range: (1 ~ 65535)
Failure code F063h	The setting value of P5-95 exceeds the range: (1 ~ 65535)
Failure code F064h	The setting value of P5-96 exceeds the range: (300000 ~ 2500000)
Failure code F065h	The address specified by P5-81 is too long and the space of data array is not enough.
Failure code F066h	The setting value of P5-82 should be set to 7. Otherwise the command cannot be executed.

Failure code F067h	Data calculation error. Please decrease the setting value of (P1-44,P1-45) and keep the proportion will do.
Command code 0007h	Create E-Cam table: Flying cut
General parameters	P5-81 = Address of table (data array) P5-82 = N (30~72) (Area number of E-Cam) P1-44, P1-45 = E-gear ration (has to be setup first)
Macro parameters	<p>P5-93.H16 (high 16-bit) = S P5-93.L16 (low 16-bit) = W Among them: S (curve level) = 1~4 levels W (degree of waiting area) = -1~170 degrees W = -1 is available in firmware version V1.038 (sub29) (or the later version) P5-94 = Y (degree of synchronous area) = 0~330 degrees</p> <p>P5-95.H16 (high 16-bit) = A x C P5-95.L16 (low 16-bit) = B Among them: A (Deceleration ratio: numerator), C (Number of cutter) B (Deceleration ratio: denominator)</p> <p>P5-96 = 1000000 x R x V Among them: R (cutting ratio) = L (target cutting length) / ℓ (Length of cutter) Allowable cutting ratio: (0.05 ~ 5.0) times</p> <p>V (speed factor) = target cutting speed / speed of delivered product V=1.0: When cutting, the speed of cutter is the same as the product V=1.1: When cutting, the speed of cutter is 10% faster than the product V=0.9: When cutting, the speed of cutter is 10% slower than the product</p>

<p>Note:</p> $W' = 180 + 360/N - 360/R + Y/2$ <p>When</p> <ol style="list-style-type: none"> 1. P5-93.L16 < W', E-cam table is in error (failure code F07Ah) 2. P5-93.L16 = W', the initial speed is 0 in E-Cam table 3. P5-93.L16 > W', the initial speed > 0 in E-Cam table 	
<p>This macro will calculate the data of E-Cam table according to the above mentioned parameters, and store in data array which designated by P5-81. Parameters listed above are related to E-Cam table calculation. Please correctly setup those parameters before executing this macro.</p> <p>After this macro is executed, if the above parameters have been changed, it has to recreate the E-Cam table and this macro will have to be executed again. Data in E-Cam table will be changed after executing this macro, thus, do not execute it when E-Cam is in engaged status.</p> <p>In E-Cam application, parameters, such as P5-83 and P5-84 that are not related to this macro are not listed here. Users could setup parameters according to the real application. Please refer to Chapter 7, sections about</p> <p>After executing this macro, E-Cam table will not be saved to EEPROM automatically.</p>	
Failure code F071h	When creating the table, E-Cam is in engaged status.
Failure code F072h	P5-94 degree of synchronous area exceeds the range: (0 ~ 330)
Failure code F073h	P5-93.H16 curve level exceeds the range: (1 ~ 4)
Failure code F074h	P5-93.L16 degree of waiting area exceeds the range: (0 ~ 170)
Failure code F075h	The setting value of P5-96 exceeds the range: (50000 ~ 5000000)
Failure code F076h	P5-82 area number of E-Cam exceeds the range: (30 ~ 72)
Failure code F077h	The address specified by P5-81 is too long and the space of data array is not enough.
Failure code F078h	Data calculation error. Please decrease the setting value of (P1-44, P1-45) and keep the proportion will do.
Failure code F079h	Acceleration degree is too small, then please decrease the value of waiting area (W), synchronous area (Y) or curve level (S).
Failure code F07Ah	Waiting area is too small, then please increase the value of acceleration area (W) or decrease the value of synchronous area (Y)

Command code 0008h	E-Cam curve scaling (P5-19) is effective immediately
Macro parameters	N/A
<p>This macro can be triggered when E-cam is engaged. P5-19 is effective immediately.</p> <p>Usually, E-Cam scaling is only changed by P5-19 when it entering the engaged condition (see transition 3). It cannot be changed in engaged condition. E-Cam scaling only can be changed after one E-Cam cycle so as to make sure the E-Cam can return to the original position without accumulative error.</p> <pre> graph TD Engaged["Engaged: 1"] -- 5 --> Stop["Stop: 0"] Engaged -- 4 --> Lead["Lead: 2"] Stop -- 1 --> Lead Lead -- 2 --> Stop Lead -- 3 --> Engaged </pre> <p>P5-19 is loaded into E-Cam scaling</p>	
<p>In application, two ways can change the setting of E-Cam curve scaling.</p> <ol style="list-style-type: none"> 1. P5-88.X2 = 1: When E-Cam is engaged, setup this bit at the same time. Function of P5-19 will be enabled immediately. 2. Use macro#8: Everytime when this macro command is triggered, function of P5-19 will be enabled. However, if the value of P5-19 is changed and this marco is not triggered, function of P5-19 will not be enabled. This macro command has to be triggered again. 	
Failure code	N/A

Command code 000Ch	Change position X, where E-Cam is engaged: E-Cam disengages after rotating one cycle at forward direction.
General parameters	N/A
Macro parameters	P5-93 = New engaged position X. Unit: pulse number of master axis. Monitor variable 062(3Eh): It displays the current engaged position (X) of master axis.

This macro command can change the engaged position even when E-Cam is engaged. It will automatically calculate the residual engaged length. E-Cam will disengage after rotating one cycle at forward direction. Users have to set P5-88.U to 2, 4, 6, otherwise, the E-cam will not disengage.

E-Cam will disengage when alarm occurs or the power supply is cut off. If users desire E-Cam to re-engage at the last disengaged position and continue its operation, it is recommended to record the disengaged position (X) and resume the operation by this macro command. Please note that when E-Cam is disengaged, the servo position might slightly shift and therefore cause position error when E-Cam re-engages again.

The Engaged direction is in forward direction (Master axis operates at forward direction):

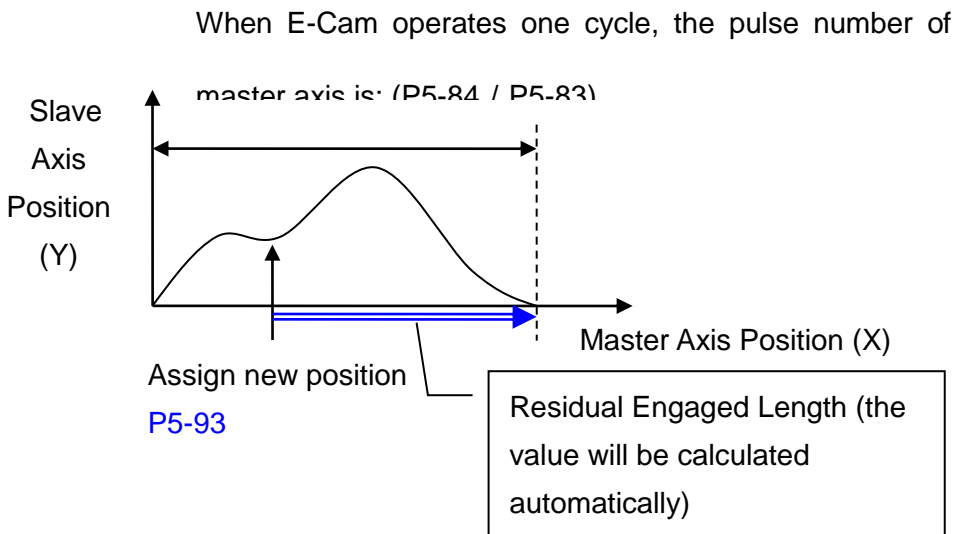

Note: When using this macro command, it would be better to execute this command before operate the master axis.

Failure code F0C1h	When executing this macro command, E-Cam is not in engaged status. To modify the engaged position only when E-Cam is engaged.
Failure code F0C2h	The setting value of P5-93 is in error. The value cannot less than 0. It should ≥ 0 .
Failure code F0C3h	The setting value of P5-93 is in error. The value has to less than the value of (P5-84 / P5-83)

Command code 000Dh	Calculate the error between E-Cam and indexing coordinates for PR positioning.
General Parameters	N/A
Macro Parameters	<p>P5-93.Low_Word = DCBA: UZYX (8 digits, HEX) YX (PR number) = 0~0x3F (it is invalid when the value is set to 0) UZ: The value has to be set to 0. BA (Function of P5-95): 0 (Use avoid point) · 1 (Use available forward rate, V1.038 sub53) DC (Inhibit reverse rotation): 0 (invalid), 1(Inhibit reverse rotation, V1.038 sub53)</p> <p>P5-95: Avoid point (cannot pass this point) = 0 ~ 100 (%) of E-Cam cycle or available forward rate 0 ~ 100 (%)</p>

Monitor variable 091(5Bh): It displays the current indexing coordinate position (PUU)

When E-Cam is engaged, and the motor is stopped because of Servo Off or alarm occurs, it would cause position error between the actual position and E-Cam position. After re-servo On, this macro command can be used to calculate the correction value and write the value into the specified PR for incremental positioning. So that the motor can return to the ideal E-Cam position.

When using this macro command:

1. P5-88.X1 = 1 to make E-Cam keep engaging when servo Off and continue to calculate E-Cam position.
2. The height of indexing coordinate and E-Cam coordinate should be the same: P2-52= ECAM_H (The moving distance when E-cam operates one cycle)
3. E-Cam table scaling (P5-19) must be 1.0 time
4. When E-Cam is engaged for the first time, 0 degree of E-cam should aim at 0 degree of indexing coordinate.

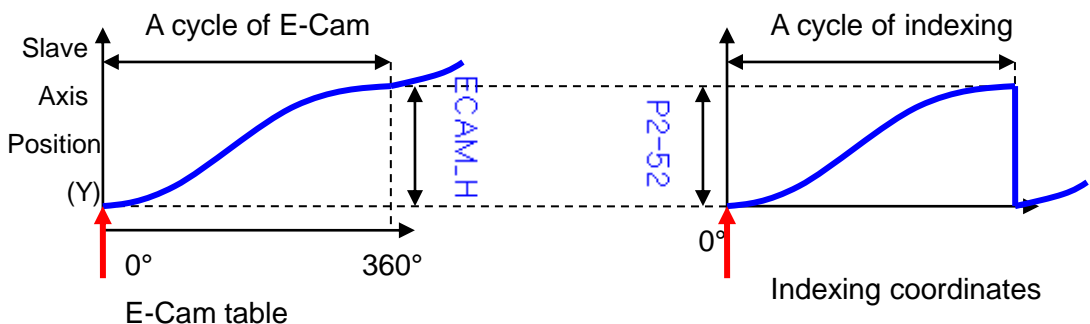



Note 1: ECAM_H (height of E-Cam table) = E-Cam table (last point - first point)

Note 2: Indexing coordinate = (absolute coordinates / P2-52) take remainder.

Note 3: Use PR command for incremental positioning control.

When motor moves from the current position to the target position, it can operate at forward or reverse direction. Due to the cyclic operation, the motor will travel to the specified position either at forward or reverse direction. However, the moving distance is different between both. Use avoid point to plan the timing of forward and reverse rotation.

* **Avoid point:** the point that cannot be past by the planned PR.

-  : E-Cam current position
-  : E-Cam current position
-  : E-Cam avoid point Θ , which is set by P5-95

$$\Theta = 360^\circ \times P5-95 \%$$

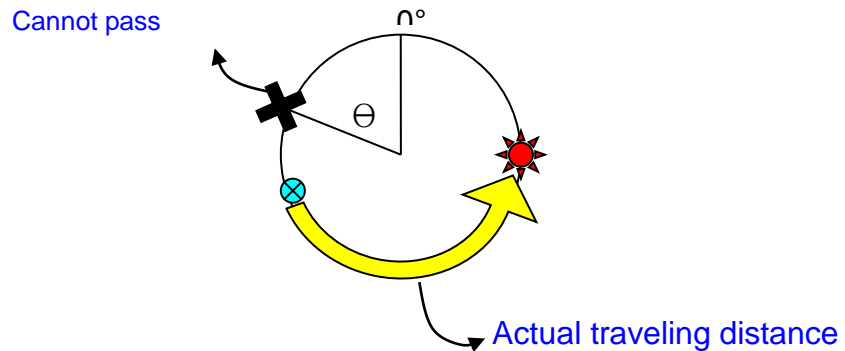

Failure code F0D1h	E-Cam is not engaged when executing this macro command. E-Cam should be engaged.
Failure code F0D2h	The value of P5-93.YX (PR number) exceeds the range: 1 ~ 0x3F
Failure code F0D3h	The value of P5-95 (available forward rate) exceeds the range: 0 ~ 100 (%)
Failure code F0D5h	The position correction value does not exist. This macro command might be triggered twice.
Failure code F0D6h	When re-servo On, E-cam is not engaged.
Failure code F0D7h	The height (Y axis) of E-Cam table is not equal to the value of P2-52.
Failure code F0D8h	P5-19 is not equal to 1
Failure code F0D9h	P5-93.BA, P5-95 exceeds the range: 0 ~ 1
Failure code F0DAh	The setting value of P5-93.DC (reverse inhibit) exceeds the range: 0 ~ 1
Failure code F0DBh	The function of reverse inhibit has failed. Do not use macro command #D, #10h consecutively.

<p>Command code 000Eh</p>	<p>Perform E-Cam alignment immediately and write the correction value into the specified PR.</p>
<p>Macro parameters</p>	<p>P5-93 = DCBA : UZYX (8 digits, HEX) YX (PR number) = 0~0x3F, it is invalid when the value is set to 0. UZ (Max. alignment correction rate) = 0~0x64 (%) A (Trigger the specified PR directly) = 1: On, 0: Off DCB = has to be set to 0 P5-94 (DI delay time compensation) = -25000 ~ +25000; Unit: usec. P5-95 (available forward rate) = 0 ~ 100 (%) P5-96 (target position of alignment X); Unit: pulse number of master axis = 0 ~ (P5-84/P5-83) – 1.</p>
<p>Monitor variable 062(3Eh): It displays the current engaged position of master axis (X)</p>	
<p>This macro command can move the engaged position to the alignment target position (X) when E-Cam is engaged. And write the alignment correction value into the specified PR. During E-Cam operation (When E-Cam is engaged), if desire to quickly align the E-cam position to the mechanical referral point, sensor can be used to trigger DI.EVx to execute this macro command. After E-Cam alignment is completed, the engaged position will move to the new position. The excess or not enough moving distance after E-Cam operates one cycle is called alignment correction value. It will be written into PR specified by P5-93.YX. PR incremental command can be used to compensate this value so that the slave axis position will remain and offset the phase of E-Cam to align the referral position of machine. For some applications, set value of P5-93.YX to 0 will do. Please note that PR can be executed only when triggering the host controller.</p>	
<div style="text-align: center;"> <p>Pulse number of master axis after rotating a cycle: (P5-84/P5-83) = L</p> </div>	
<p>* P5-93.UZ is able to limit the max. correction rate. The alignment target position ★ will be different from P5-96. $\text{alignment target position} \star - \text{current engaged position} / L \leq P5-93.UZ \%$ * DI time delay compensation can be set via P5-94, it can correct the error caused by different speed of motion.</p>	

When E-Cam moves from current position to the target one, it can rotate at forward or reverse position. Due to the cyclic operation, it can reach the target position either at forward or reverse direction. However, the moving distance between both is usually different. Use available forward rate to plan the timing of forward and reverse rotation.

* Available forward rate: The available max. proportion of forward path

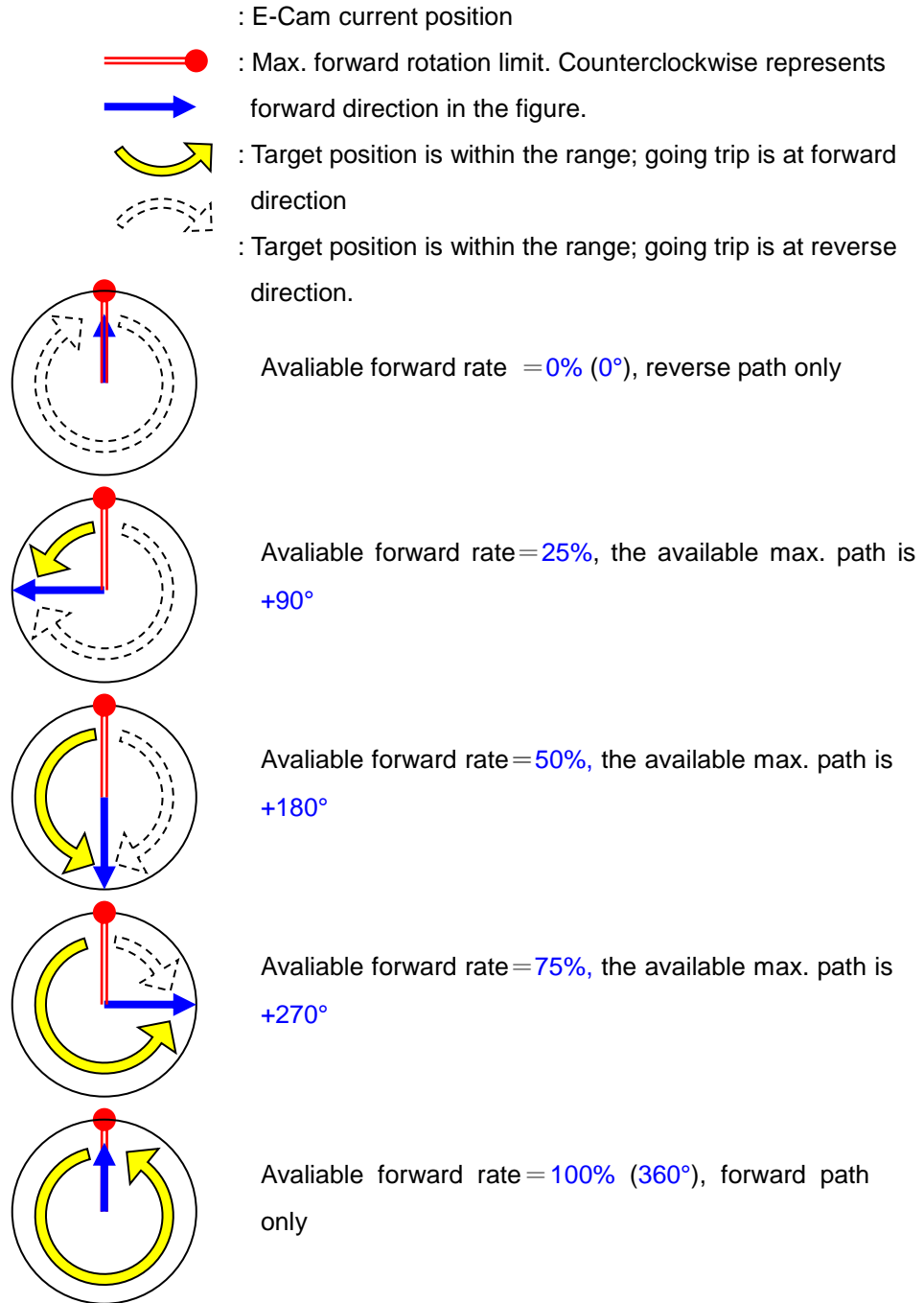

Failure code F0E1h	When executing this macro, E-Cam is not engaged. E-Cam has to engage to execute alignment correction.
Failure code F0E2h	The setting value of P5-93.YX (PR number) exceeds the range: 0 ~ 0x3F
Failure code F0E3h	The setting value of P5-93.UZ (Max. alignment correction rate) exceeds the range: 0~0x64 (%)

Failure code F0E4h	The setting value of P5-94 (DI delay time compensation) exceeds the range: -10000 ~ +10000
Failure code F0E5h	The setting value of P5-95 (Avaliable forward rate) exceeds the rnage: 0 ~ 100 (%)
Failure code F0E6h	The setting value of P5-96 (alignment target position) exceeds the range: 0 ~ (P5-84/P5-83) - 1

Command code 000Fh	Calculate the moving distance between current and target position of E-Cam for PR positioning.
General parameters	N/A
Macro parameters	<p>P5-93.Low_Word = UZYX (4 digits, HEX) YX (PR number of going trip) = 0~0x3F, it is invalid if the value is set to 0. UZ (PR number of return trip) = 0~0x3F, it is invalid if the value is set to 0. P5-93.Hi_Word = it has to be set to 0</p> <p>P5-95 (Avaliable forward rate) = 0 ~ 100 (%) P5-96 (target position X); Unit: pulse number of master axis = 0 ~ (P5-84/P5-83) - 1</p>

Monitor variable 062(3Eh): It displays the current engaged position (X) of master axis.

This macro command calculates the moving distance between current and target engaged position (X) and write into the specified PR.

During E-Cam operation, if users desire to move the slave axis to the specified position when master axis stops and still in engaged status, this macro command can calculates the correct moving distance (Y_Drift) of going trip for PR positioning.

When master axis resumes the operation, use another PR to run the moving distance of return trip (-Y_Drift), it can back to the original position (moving distance of going trip + moving distance of return trip = 0). E-Cam position remains the same.

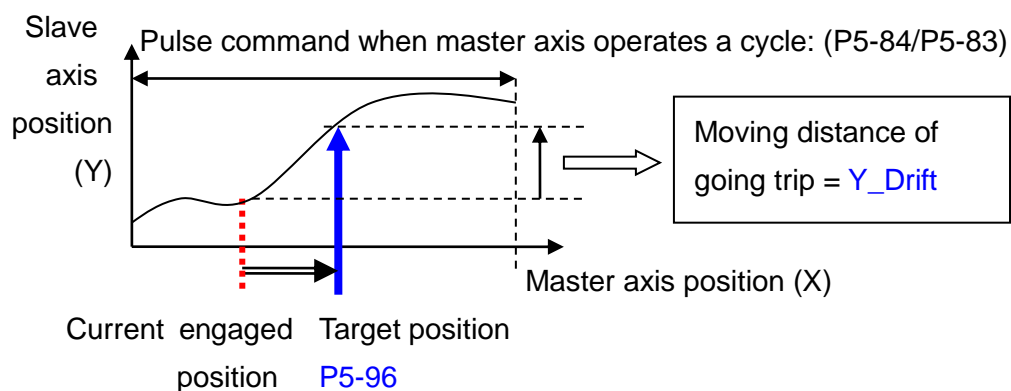

Note: PR command must be the incremental command, regardless in going trip or return trip.

When E-Cam moves from current position to the target one, it can rotate at forward or reverse position. Due to the cyclic operation, it can reach the target position either at forward or reverse direction. However, the moving distance between both is usually different. Use available forward rate to plan the timing of forward and reverse rotation.

* Available forward rate: The available max. proportion of forward path

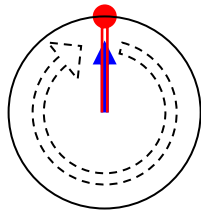
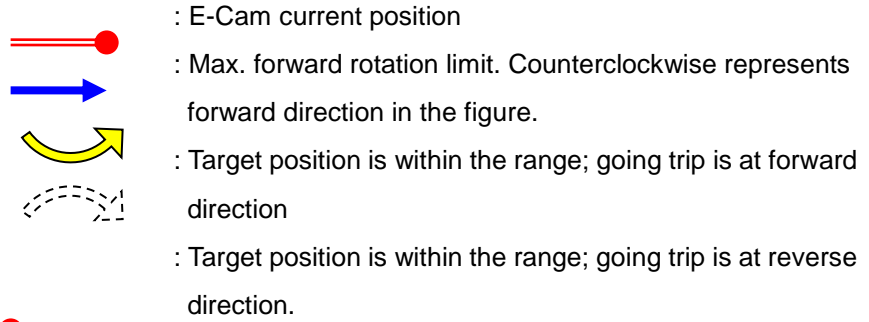

Available forward rate = 0% (0°), reverse path only

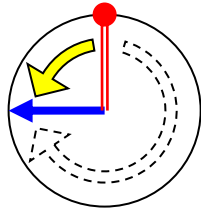

Available forward rate = 25%, the available max. path is +90°

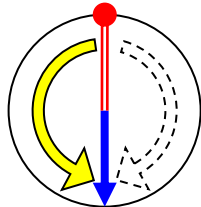

Available forward rate = 50%, the available max. path is +180°

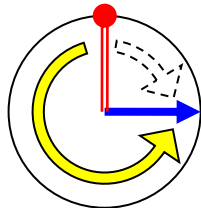

Available forward rate = 75%, the available max. path is +270°

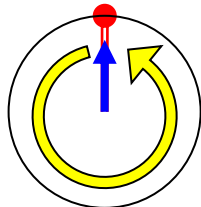

Available forward rate = 100% (360°), forward path only

Failure code F0F1h	When executing this macro, E-Cam is not engaged. E-Cam has to engage to change the engaged position.
Failure code F0F2h	The setting value of P5-93.YX (PR number of going trip) exceeds the range: 0 ~ 0x3F
Failure code F0F3h	The setting value of P5-93.UZ (PR number of return trip) exceeds the range: 0 ~ 0x3F
Failure code F0F5h	The setting value of P5-95 (Available forward rate) exceeds the range: 0 ~ 100 (%)
Failure code F0F6h	The setting value of P5-96 (target position) exceeds the range: 0 ~ (P5-84/P5-83) - 1
Command code 0010h	E-Cam stops for one cycle and resumes its operation at next cycle.
General parameters	N/A
Macro parameters	Value of P5-93 has to be set to 0.

After E-Cam is engaged, this macro command can stop the slave axis for a cycle of distance regardless the E-Cam degree.

The following conditions have to be established when using this macro command.

1. E-Cam must be in engaged status.
2. E-Cam must be the forward operation curve (including straight line) so it can stop temporarily.

Refer to the figure below, triggering this macro command, E-Cam will stop for one cycle regardless the degree (X) where E-Cam is.

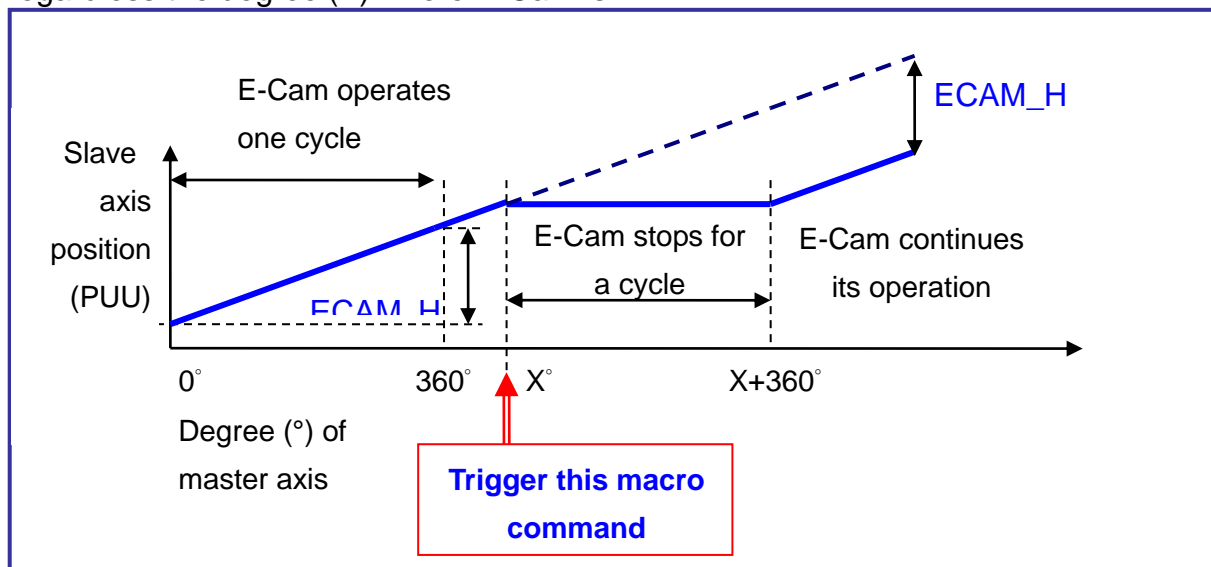

Note 1: $ECAM_H$ (E-Cam pause distance) = table (last point – first point) x P5-19 (the effective scaling)

Note 2: This function can accumulate times. If the command is triggered for N times consecutively, it will stop the E-Cam for N cycles. The accumulated pause distance cannot exceed ($>2^{31}$), or the macro command will be disabled.

Note 3: When E-Cam resumes the operation, the accumulated pause distance will be cleared to 0.

Failure code F101h	When executing this macro command, E-Cam is not engaged.
Failure code F102h	The setting value of P5-93 is incorrect: It has to be set to 0.
Failure code F103h	E-Cam has to operate at forward direction. Please check the E-Cam table and make sure P5-19 > 0.
Failure code F104h	The accumulated pause distance exceeds 2^{31} . Do not execute this macro command consecutively.

P5-98	EVON	PR# Triggered by Event Rising-Edge		Address: 05C4H 05C5H
	Operational Interface :	Panel / Software	Communication	Related Section: -
	Default :	0		
	Control Mode :	PR		
	Unit :	-		
	Range :	0000 ~ 0xDDDD		
	Data Size :	16bit		
	Format :	HEX		

Settings : Four items: UZYX
 When EVx is set to ON, the PR# will be executed.
 X=0: When EV1 is ON, PR will not be triggered.
 X=1~D: When EV1 is ON, execute PR # 51~63.
 Y=0: When EV2 is ON, PR will not be triggered.
 Y=1~D: When EV2 is ON, execute PR # 51~63.
 Note: EV3 and EV4 are supported after firmware V1.009.

Z=0: When EV3 is ON, PR will not be triggered.
 Z=1~D: When EV3 is ON, execute PR # 51~63.
 U=0: When EV3 is ON, PR will not be triggered.
 U=1~D: When EV4 is ON, execute PR # 51~63.

P5-99

EVOF	PR# Triggered by Event Falling-Edge		Address: 05C6H 05C7H
Operational Interface :	Panel / Software	Communication	Related Section: -
Default :	0		
Control Mode :	PR		
Unit :	-		
Range :	0000 ~ 0xDDDD		
Data Size :	16bit		
Format :	HEX		

Settings : Four items: UZYX

When EVx is set to OFF, the PR# will be executed.

X=0: When EV1 is OFF, PR will not be triggered.

X=1~D: When EV1 is OFF, execute PR # 51~63.

Y=0: When EV2 is OFF, PR will not be triggered.

Y=1~D: When EV2 is OFF, execute PR # 51~63.

Note: EV3 and EV4 are supported after firmware V1.009.

Z=0: When EV3 is OFF, PR will not be triggered.

Z=1~D: When EV3 is OFF, execute PR # 51~63.

U=0: When EV4 is OFF, PR will not be triggered.

U=1~D: When EV4 is OFF, execute PR # 51~63.

P6-xx PR Parameters (Please refer to Chapter 7 for detailed setting)

P6-00	ODEF	Homing Definition		Address: 0600H 0601H
	Operational Interface :	Panel / Software	Communication	Related Section; 7.10
	Default :	0x00000000		
	Control Mode :	PR		
	Unit :	-		
	Range :	0x00000000 ~ 0x10FFFF3F		
	Data Size :	32bit		
	Format :	HEX		

Settings : Homing definition:

31 ~ 28	27 ~ 24	23 ~ 20	19 ~ 16	15 ~ 12	11 ~ 8	7 ~ 4	3 ~ 0 BIT
BOOT	-	DLY	-	DEC1	ACC	PATH	

- **PATH:** Path type (4 bit)
 - 0: Stop: Homing complete and stop
 - 1 ~ 63: Auto: Homing complete and execute the specified path
- **ACC:** Select 0~F for acceleration time and corresponds to P5-20~P5-35.
- **DEC1:** The deceleration time selection of 1st homing, the setting value of DEC is 0~F and corresponds to P5-20 ~ P5-35.
- **DLY:** Select 0~F for the delay time and corresponds to P5-40 ~ P5-55
- **BOOT:** When the servo drive applies to the power, if it will be executed searching the origin.
 - 0: Do not do homing
 - 1: Execute homing automatically (SRV ON for the first time after applying to power)

- Apart from the above mentioned definition, the related setting of homing also includes:
 1. P5-04 Homing mode
 2. P5-05 ~ P5-06 Speed setting of searching the origin
 3. P6-01: ORG_DEF is the location of the origin. It may not be 0. This function is the offset of coordinate system.
 - A. After the origin is found (Sensor or Z), it has to decelerate to stop. The stop position will exceed the origin for a short distance.

If it does not return to the origin, set PATH to 0.

If it needs to return to the origin, set PATH to non-zero value and set PABS = ORG_DEF.
 - B. If the origin is found (Sensor or Z), desire to move an offset S and define the coordinate as P after moving, then PATH = non-zero and set ORG_DEF = P-S. The absolute position command = P.

P6-01	ODAT	Origin Definition						Address: 0602H 0603H		
	Operational Interface :	Panel / Software			Communication			Related Section: 7.10		
	Default :	0								
	Control Mode :	PR								
	Unit :	-								
	Range :	-2147483648 ~ +2147483647								
	Data Size :	32bit								
	Format :	DEC								
Settings :	Value of origin definition:									
	31 ~ 28	27 ~ 24	23 ~ 20	19 ~ 16	15 ~ 12	11 ~ 8	7 ~ 4	3 ~ 0 BIT		
ORG_DEF (32 bit)										

P6-02	PDEF1	PATH#1 Definition		Address: 0604H 0605H
	Operational Interface :	Panel / Software	Communication	Related Section: 7.10
	Default :	0x00000000		
	Control Mode :	PR		
	Unit :	-		
	Range :	0x00000000 ~ 0xFFFFFFFF		
	Data Size :	32bit		
	Format :	HEX		

Settings : Properties of PATH# 1:

	31 ~ 28	27 ~ 24	23 ~ 20	19 ~ 16	15 ~ 12	11 ~ 8	7 ~ 4	3 ~ 0 BIT
P6-02	-	-	DLY	-	-	-	OPT	TYPE
P6-03	DATA (32 bit)							

- TYPE, OPT:

OPT				TYPE
7	6	5	4 BIT	3 ~ 0 BIT
-	UNIT	AUTO	INS	1: SPEED, Speed setting control
CMD		OVLP	INS	2: SINGLE, Positioning control. It will load in the next path when finished.
				3: AUTO positioning control. It will load in the next path when finished.
-	-	-	INS	7: JUMP to the specified path
-	-	AUTO	INS	8: Write the specified parameter to the specified path

- TYPE: 1 ~ 3 accept DO.STP stop and software limit.
- INS: When executing this PR, it interrupts the previous one.
- OVLP: Allow the overlap of the next path. The overlap is not allowed in speed mode. When overlap happens in position mode, DLY has no function.
- AUTO: When PR procedure completes, the next procedure will be loaded in automatically.
- CMD: Refer to Chapter 7 for PR command description.
- DLY: 0 ~ F, delay time number (4 BIT). The delay after executing this PR. The external INS is invalid.

DLY (4)

 Index P5-40 ~ P5-55

P6-03	PDAT1	PATH# 1 Data		Address: 0606H 0607H
	Operational Interface :	Panel / Software	Communication	Related Section: 7.10
	Default :	0		
	Control Mode :	PR		
	Unit :	-		
	Range :	-2147483648 ~ +2147483647		
	Data Size :	32bit		
	Format :	DEC		
Settings :	PATH# 1 Data			

31 ~ 28	27 ~ 24	23 ~ 20	19 ~ 16	15 ~ 12	11 ~ 8	7 ~ 4	3 ~ 0 BIT
DATA (32 bit)							

Property of P6-02; P6-03 corresponds to the target position of P6-02 or jump to PATH_NO.

Note : PATH (procedure)

P6-04	PDEF2	PATH# 2 Definition		Address: 0608H 0609H
	Operational Interface :	Panel / Software	Communication	Related Section: 7.10
	Default :	0x00000000		
	Control Mode :	PR		
	Unit :	-		
	Range :	0x00000000 ~ 0xFFFFFFFF		
	Data Size :	32bit		
	Format :	HEX		
Settings :	Please refer to the description of P6-02			

P6-05	PDAT2	PATH# 2 Data		Address: 060AH 060BH
	Operational Interface :	Panel / Software	Communication	Related Section: 7.10
	Default :	0		
	Control Mode :	PR		
	Unit :	-		
	Range :	-2147483648 ~ +2147483647		
	Data Size :	32bit		
	Format :	DEC		
	Settings :	Please refer to the description of P6-03.		

P6-06	PDEF3	PATH# 3 Definition		Address: 060CH 060DH
	Operational Interface :	Panel / Software	Communication	Related Section: 7.10
	Default :	0x00000000		
	Control Mode :	PR		
	Unit :	-		
	Range :	0x00000000 ~ 0xFFFFFFFF		
	Data Size :	32bit		
	Format :	HEX		
	Settings :	Please refer to the description of P6-02.		

P6-07	PDAT3	PATH# 3 Data		Address: 060EH 060FH
	Operational Interface :	Panel / Software	Communication	Related Section: 7.10
	Default :	0		
	Control Mode :	PR		
	Unit :	-		
	Range :	-2147483648 ~ +2147483647		
	Data Size :	32bit		

Format : DEC

Settings : Please refer to the description of P6-03.

P6-08	PDEF4	PATH# 4 Definition		Address: 0610H 0611H
	Operational Interface :	Panel / Software	Communication	Related Section: 7.10
	Default :	0x00000000		
	Control Mode :	PR		
	Unit :	-		
	Range :	0x00000000 ~ 0xFFFFFFFF		
	Data Size :	32bit		
	Format :	HEX		

Settings : Please refer to the description of P6-02.

P6-09	PDAT4	PATH# 4 Data		Address: 0612H 0613H
	Operational Interface :	Panel / Software	Communication	Related Section: 7.10
	Default :	0		
	Control Mode :	PR		
	Unit :	-		
	Range :	-2147483648 ~ +2147483647		
	Data Size :	32bit		
	Format :	DEC		

Settings : Please refer to the description of P6-03.

P6-10	PDEF5	PATH# 5 Definition		Address: 0614H 0615H
	Operational Interface :	Panel / Software	Communication	Related Section: 7.10
	Default :	0x00000000		
	Control Mode :	PR		
	Unit :	-		
	Range :	0x00000000 ~ 0xFFFFFFFF		
	Data Size :	32bit		
	Format :	HEX		

Settings : Please refer to the description of P6-02.

P6-11	PDAT5	PATH# 5 Data		Address: 0616H 0617H
	Operational Interface :	Panel / Software	Communication	Related Section: 7.10
	Default :	0		
	Control Mode :	PR		
	Unit :	-		
	Range :	-2147483648 ~ +2147483647		
	Data Size :	32bit		
	Format :	DEC		

Settings : Please refer to the description of P6-03.

P6-12	PDEF6	PATH# 6 Definition		Address: 0618H 0619H
	Operational Interface :	Panel / Software	Communication	Related Section: 7.10
Default :	0x00000000			
Control Mode :	PR			
Unit :	-			
Range :	0x00000000 ~ 0xFFFFFFFF			
Data Size :	32bit			
Format :	HEX			

Settings : Please refer to the description of P6-02.

P6-13	PDAT6	PATH# 6 Data		Address: 061AH 061BH
	Operational Interface :	Panel / Software	Communication	Related Section: 7.10
Default :	0			
Control Mode :	PR			
Unit :	-			
Range :	-2147483648 ~ +2147483647			
Data Size :	32bit			
Format :	DEC			

Settings : Please refer to the description of P6-03.

P6-14	PDEF7	PATH# 7 Definition		Address: 061CH 061DH
	Operational Interface :	Panel / Software	Communication	Related Section: 7.10
Default :	0x00000000			
Control Mode :	PR			
Unit :	-			
Range :	0x00000000 ~ 0xFFFFFFFF			
Data Size :	32bit			
Format :	HEX			
Settings : Please refer to the description of P6-02.				

P6-15	PDAT7	PATH# 7 Data		Address: 061EH 061FH
	Operational Interface :	Panel / Software	Communication	Related Section: 7.10
Default :	0			
Control Mode :	PR			
Unit :	-			
Range :	-2147483648 ~ +2147483647			
Data Size :	32bit			
Format :	DEC			
Settings : Please refer to the description of P6-03.				

P6-16	PDEF8	PATH# 8 Definition		Address: 0620H 0621H
	Operational Interface :	Panel / Software	Communication	Related Section: 7.10
Default :	0x00000000			
Control Mode :	PR			
Unit :	-			
Range :	0x00000000 ~ 0xFFFFFFFF			
Data Size :	32bit			
Format :	HEX			

Settings : Please refer to the description of P6-02.

P6-17	PDAT8	PATH# 8 Data		Address: 0622H 0623H
	Operational Interface :	Panel / Software	Communication	Related Section: 7.10
Default :	0			
Control Mode :	PR			
Unit :	-			
Range :	-2147483648 ~ +2147483647			
Data Size :	32bit			
Format :	DEC			

Settings : Please refer to the description of P6-03.

P6-18	PDEF9	PATH# 9 Definition		Address: 0624H 0625H
	Operational Interface :	Panel / Software	Communication	Related Section: 7.10
Default :	0x00000000			
Control Mode :	PR			
Unit :	-			
Range :	0x00000000 ~ 0xFFFFFFFF			
Data Size :	32bit			
Format :	HEX			
Settings : Please refer to the description of P6-02.				

P6-19	PDAT9	PATH# 9 Data		Address: 0626H 0627H
	Operational Interface :	Panel / Software	Communication	Related Section: 7.10
Default :	0			
Control Mode :	PR			
Unit :	-			
Range :	-2147483648 ~ +2147483647			
Data Size :	32bit			
Format :	DEC			
Settings : Please refer to the description of P6-03.				

P6-20	PDEF10	PATH# 10 Definition		Address: 0628H 0629H
	Operational Interface :	Panel / Software	Communication	Related Section: 7.10
Default :	0x00000000			
Control Mode :	PR			
Unit :	-			
Range :	0x00000000 ~ 0xFFFFFFFF			
Data Size :	32bit			

Format :	HEX
----------	-----

Settings : Please refer to the description of P6-02.

P6-21	PDAT10	PATH# 10 Data		Address: 062AH 062BH
	Operational Interface :	Panel / Software	Communication	Related Section: 7.10
	Default :	0		
	Control Mode :	PR		
	Range :	-2147483648 ~ +2147483647		
	Data Size :	32bit		
	Format :	DEC		

Settings : Please refer to the description of P6-03

P6-22	PDEF11	PATH# 11 Definition		Address: 062CH 062DH
	Operational Interface :	Panel / Software	Communication	Related Section: 7.10
	Default :	0x00000000		
	Control Mode :	PR		
	Unit :	-		
	Range :	0x00000000 ~ 0xFFFFFFFF		
	Data Size :	32bit		
	Format :	HEX		

Settings : Please refer to the description of P6-02.

P6-23	PDAT11	PATH# 11 Data		Address: 062EH 062FH
	Operational Interface :	Panel / Software	Communication	Related Section: 7.10
	Default :	0		
	Control Mode :	PR		
	Unit :	-		
	Range :	-2147483648 ~ +2147483647		
	Data Size :	32bit		
	Format :	DEC		
	Settings : Please refer to the description of P6-03.			

P6-24	PDEF12	PATH# 12 Definition		Address: 0630H 0631H
	Operational Interface :	Panel / Software	Communication	Related Section: 7.10
	Default :	0x00000000		
	Control Mode :	PR		
	Unit :	-		
	Range :	0x00000000 ~ 0xFFFFFFFF		
	Data Size :	32bit		
	Format :	HEX		
	Settings : Please refer to the description of P6-02.			

P6-25	PDAT12	PATH# 12 Data		Address: 0632H 0633H
Operational Interface :	Panel / Software	Communication	Related Section: 7.10	
Default :	0			
Control Mode :	PR			
Unit :	-			
Range :	-2147483648 ~ +2147483647			
Data Size :	32bit			
Format :	DEC			
Settings : Please refer to the description of P6-03.				

P6-26	PDEF13	PATH# 13 Definition		Address: 0634H 0635H
Operational Interface :	Panel / Software	Communication	Related Section: 7.10	
Default :	0x00000000			
Control Mode :	PR			
Unit :	-			
Range :	0x00000000 ~ 0xFFFFFFFF			
Data Size :	32bit			
Format :	HEX			
Settings : Please refer to the description of P6-02.				

P6-27	PDAT13	PATH# 13 Data		Address: 0636H 0637H
	Operational Interface :	Panel / Software	Communication	Related Section: 7.10
	Default :	0		
	Control Mode :	PR		
	Unit :	-		
	Range :	-2147483648 ~ +2147483647		
	Data Size :	32bit		
	Format :	DEC		
	Settings : Please refer to the description of P6-03.			

P6-28	PDEF14	PATH# 14 Definition		Address: 0638H 0639H
	Operational Interface :	Panel / Software	Communication	Related Section: 7.10
	Default :	0x00000000		
	Control Mode :	PR		
	Unit :	-		
	Range :	0x00000000 ~ 0xFFFFFFFF		
	Data Size :	32bit		
	Format :	HEX		
	Settings : Please refer to the description of P6-03.			

P6-29	PDAT14	PATH# 14 Data		Address: 063AH 063BH
	Operational Interface :	Panel / Software	Communication	Related Section: 7.10
Default :	0			
Control Mode :	PR			
Unit :	-			
Range :	-2147483648 ~ +2147483647			
Data Size :	32bit			
Format :	DEC			

Settings : Please refer to the description of P6-03.

P6-30	PDEF15	PATH# 15 Definition		Address: 063CH 063DH
	Operational Interface :	Panel / Software	Communication	Related Section: 7.10
Default :	0x00000000			
Control Mode :	PR			
Unit :	-			
Range :	0x00000000 ~ 0xFFFFFFFF			
Data Size :	32bit			
Format :	HEX			

Settings : Please refer to the description of P6-02.

P6-31	P DAT15	PATH# 15 Data		Address: 063EH 063FH
Operational Interface :		Panel / Software	Communication	Related Section: 7.10
Default :		0		
Control Mode :		PR		
Unit :		-		
Range :		-2147483648 ~ +2147483647		
Data Size :		32bit		
Format :		DEC		
Settings : Please refer to the description of P6-03.				

P6-32	P DEF16	PATH# 16 Definition		Address: 0640H 0641H
Operational Interface :		Panel / Software	Communication	Related Section: 7.10
Default :		0x00000000		
Control Mode :		PR		
Unit :		-		
Range :		0x00000000 ~ 0xFFFFFFFF		
Data Size :		32bit		
Format :		HEX		
Settings : Please refer to the description of P6-02.				

P6-33	PDAT16 PATH# 16 Data		Address: 0642H 0643H
Operational Interface :	Panel / Software	Communication	Related Section: 7.10
Default :	0		
Control Mode :	PR		
Unit :	-		
Range :	-2147483648 ~ +2147483647		
Data Size :	32bit		
Format :	DEC		
Settings :	Please refer to the description of P6-03.		

P6-34	PDEF17 PATH# 17 Definition		Address: 0644H 0645H
Operational Interface :	Panel / Software	Communication	Related Section: 7.10
Default :	0x00000000		
Control Mode :	PR		
Unit :	-		
Range :	0x00000000 ~ 0xFFFFFFFF		
Data Size :	32bit		
Format :	HEX		
Settings :	Please refer to the description of P6-02.		

P6-35	PDAT17 PATH# 17 Data		Address: 0646H 0647H
Operational Interface :	Panel / Software	Communication	Related Section: 7.10
Default :	0		
Control Mode :	PR		
Unit :	-		
Range :	-2147483648 ~ +2147483647		
Data Size :	32bit		

Format :	DEC
----------	-----

Settings : Please refer to the description of P6-03.

P6-36	PDEF18	PATH# 18 Definition		Address: 0648H 0649H
	Operational Interface :	Panel / Software	Communication	Related Section: 7.10
	Default :	0x00000000		
	Control Mode :	PR		
	Unit :	-		
	Range :	0x00000000 ~ 0xFFFFFFFF		
	Data Size :	32bit		
	Format :	HEX		

Settings : Please refer to the description of P6-02.

P6-37	PDAT18	PATH# 18 Data		Address: 064AH 064BH
	Operational Interface :	Panel / Software	Communication	Related Section: 7.10
	Default :	0		
	Control Mode :	PR		
	Unit :	-		
	Range :	-2147483648 ~ +2147483647		
	Data Size :	32bit		
	Format :	DEC		

Settings : Please refer to the description of P6-03.

P6-38	PDEF19	PATH# 19 Definition		Address: 064CH 064DH
	Operational Interface :	Panel / Software	Communication	Related Section: 7.10
Default :	0x00000000			
Control Mode :	PR			
Unit :	-			
Range :	0x00000000 ~ 0xFFFFFFFF			
Data Size :	32bit			
Format :	HEX			

Settings : Please refer to the description of P6-02.

P6-39	PDAT19	PATH# 19 Data		Address: 064EH 064FH
	Operational Interface :	Panel / Software	Communication	Related Section: 7.10
Default :	0			
Control Mode :	PR			
Unit :	-			
Range :	-2147483648 ~ +2147483647			
Data Size :	32bit			
Format :	DEC			

Settings : Please refer to the description of P6-03.

P6-40	PDEF20	PATH# 20 Definition		Address: 0650H 0651H
	Operational Interface :	Panel / Software	Communication	Related Section: 7.10
	Default :	0x00000000		
	Control Mode :	PR		
	Unit :	-		
	Range :	0x00000000 ~ 0xFFFFFFFF		
	Data Size :	32bit		
	Format :	HEX		

Settings : Please refer to the description of P6-02.

P6-41	PDAT20	PATH# 20 Data		Address: 0652H 0653H
	Operational Interface :	Panel / Software	Communication	Related Section: 7.10
	Default :	0		
	Control Mode :	PR		
	Unit :	-		
	Range :	-2147483648 ~ +2147483647		
	Data Size :	32bit		
	Format :	DEC		

Settings : Please refer to the description of P6-03.

P6-42	PDEF21	PATH# 21 Definition		Address: 0654H 0655H
	Operational Interface :	Panel / Software	Communication	Related Section: 7.10
Default :	0x00000000			
Control Mode :	PR			
Unit :	-			
Range :	0x00000000 ~ 0xFFFFFFFF			
Data Size :	32bit			
Format :	HEX			
Settings : Please refer to the description of P6-02.				

P6-43	PDAT21	PATH# 21 Data		Address: 0656H 0657H
	Operational Interface :	Panel / Software	Communication	Related Section: 7.10
Default :	0			
Control Mode :	PR			
Unit :	-			
Range :	-2147483648 ~ +2147483647			
Data Size :	32bit			
Format :	DEC			
Settings : Please refer to the description of P6-03.				

P6-44	PDEF22	PATH# 22 Definition	Address: 0658H 0659H
	Operational Interface :	Panel / Software	Communication
	Default :	0x00000000	
	Control Mode :	PR	
	Unit :	-	
	Range :	0x00000000 ~ 0xFFFFFFFF	
	Data Size :	32bit	
	Format :	HEX	
	Settings :	Please refer to the description of P6-02.	
			Related Section: 7.10

P6-45	PDAT22	PATH# 22Data	Address: 065AH 065BH
	Operational Interface :	Panel / Software	Communication
	Default :	0	
	Control Mode :	PR	
	Unit :	-	
	Range :	-2147483648 ~ +2147483647	
	Data Size :	32bit	
	Format :	DEC	
	Settings :	Please refer to the description of P6-03.	
			Related Section: 7.10

P6-46	PDEF23	PATH# 23Definition		Address: 065CH 065DH
	Operational Interface :	Panel / Software	Communication	Related Section: 7.10
Default :	0x00000000			
Control Mode :	PR			
Unit :	-			
Range :	0x00000000 ~ 0xFFFFFFFF			
Data Size :	32bit			
Format :	HEX			

Settings : Please refer to the description of P6-02.

P6-47	PDAT23	PATH# 23Data		Address: 065EH 065FH
	Operational Interface :	Panel / Software	Communication	Related Section: 7.10
Default :	0			
Control Mode :	PR			
Unit :	-			
Range :	-2147483648 ~ +2147483647			
Data Size :	32bit			
Format :	DEC			

Settings : Please refer to the description of P6-03.

P6-48	PDEF24	PATH# 24Definition		Address: 0660H 0661H
	Operational Interface :	Panel / Software	Communication	Related Section: 7.10
	Default :	0x00000000		
	Control Mode :	PR		
	Unit :	-		
	Range :	0x00000000 ~ 0xFFFFFFFF		
	Data Size :	32bit		
	Format :	HEX		
	Settings : Please refer to the description of P6-02.			

P6-49	PDAT24	PATH# 24Data		Address: 0662H 0663H
	Operational Interface :	Panel / Software	Communication	Related Section: 7.10
	Default :	0		
	Control Mode :	PR		
	Unit :	-		
	Range :	-2147483648 ~ +2147483647		
	Data Size :	32bit		
	Format :	DEC		
	Settings : Please refer to the description of P6-03.			

P6-50	PDEF25	PATH# 25Definition		Address: 0664H 0665H
	Operational Interface :	Panel / Software	Communication	Related Section: 7.10
Default :	0x00000000			
Control Mode :	PR			
Unit :	-			
Range :	0x00000000 ~ 0xFFFFFFFF			
Data Size :	32bit			
Format :	HEX			

Settings : Please refer to the description of P6-02.

P6-51	PDAT25	PATH# 25Data		Address: 0666H 0667H
	Operational Interface :	Panel / Software	Communication	Related Section: 7.10
Default :	0			
Control Mode :	PR			
Unit :	-			
Range :	-2147483648 ~ +2147483647			
Data Size :	32bit			
Format :	DEC			

Settings : Please refer to the description of P6-03

P6-52	PDEF26	PATH# 26Definition		Address: 0668H 0669H
	Operational Interface :	Panel / Software	Communication	Related Section: 7.10
Default :	0x00000000			
Control Mode :	PR			
Unit :	-			
Range :	0x00000000 ~ 0xFFFFFFFF			
Data Size :	32bit			
Format :	HEX			
Settings : Please refer to the description of P6-02.				

P6-53	PDAT26	PATH# 26Data		Address: 066AH 066BH
	Operational Interface :	Panel / Software	Communication	Related Section: 7.10
Default :	0			
Control Mode :	PR			
Unit :	-			
Range :	-2147483648 ~ +2147483647			
Data Size :	32bit			
Format :	DEC			
Settings : Please refer to the description of P6-03.				

P6-54	PDEF27	PATH# 27Definition		Address: 066CH 066DH
	Operational Interface :	Panel / Software	Communication	Related Section: 7.10
Default :	0x00000000			
Control Mode :	PR			
Unit :	-			
Range :	0x00000000 ~ 0xFFFFFFFF			
Data Size :	32bit			
Format :	HEX			
Settings : Please refer to the description of P6-02.				

P6-55	PDAT27	PATH# 27Data		Address: 066EH 066FH
	Operational Interface :	Panel / Software	Communication	Related Section: 7.10
Default :	0			
Control Mode :	PR			
Unit :	-			
Range :	-2147483648 ~ +2147483647			
Data Size :	32bit			
Format :	DEC			
Settings : Please refer to the description of P6-03.				

P6-56	PDEF28	PATH# 28Definition		Address: 0670H 0671H
	Operational Interface :	Panel / Software	Communication	Related Section: 7.10
Default :	0x00000000			
Control Mode :	PR			
Unit :	-			
Range :	0x00000000 ~ 0xFFFFFFFF			
Data Size :	32bit			

Format :	HEX
----------	-----

Settings : Please refer to the description of P6-02.

P6-57	PDAT28	PATH# 28Data	Address: 0672H 0673H
--------------	---------------	---------------------	---------------------------------

Operational Interface :	Panel / Software	Communication	Related Section: 7.10
Default :	0		
Control Mode :	PR		
Unit :	-		
Range :	-2147483648 ~ +2147483647		
Data Size :	32bit		
Format :	DEC		

Settings : Please refer to the description of P6-03.

P6-58	PDEF29	PATH# 29Definition	Address: 0674H 0675H
--------------	---------------	---------------------------	---------------------------------

Operational Interface :	Panel / Software	Communication	Related Section: 7.10
Default :	0x00000000		
Control Mode :	PR		
Unit :	-		
Range :	0x00000000 ~ 0xFFFFFFFF		
Data Size :	32bit		
Format :	HEX		

Settings : Please refer to the description of P6-02.

P6-59	PDAT29	PATH# 29Data	Address: 0676H 0677H
--------------	---------------	---------------------	---------------------------------

Operational Interface :	Panel / Software	Communication	Related Section: 7.10
Default :	0		
Control Mode :	PR		
Unit :	-		

Range :	-2147483648 ~ +2147483647
Data Size :	32bit
Format :	DEC

Settings : Please refer to the description of P6-03.

P6-60	PDEF30	PATH# 30Definition		Address: 0678H 0679H
	Operational Interface :	Panel / Software	Communication	Related Section: 7.10
	Default :	0x00000000		
	Control Mode :	PR		
	Unit :	-		
	Range :	0x00000000 ~ 0xFFFFFFFF		
	Data Size :	32bit		
	Format :	HEX		

Settings : Please refer to the description of P6-02.

P6-61	PDAT30	PATH# 30Data		Address: 067AH 067BH
	Operational Interface :	Panel / Software	Communication	Related Section: 7.10
	Default :	0		
	Control Mode :	PR		
	Unit :	-		
	Range :	-2147483648 ~ +2147483647		
	Data Size :	32bit		
	Format :	DEC		

Settings : Please refer to the description of P6-03.

P6-62	PDEF31	PATH# 31Definition		Address: 067CH 067DH
	Operational Interface :	Panel / Software	Communication	Related Section: 7.10
Default :	0x00000000			
Control Mode :	PR			
Unit :	-			
Range :	0x00000000 ~ 0xFFFFFFFF			
Data Size :	32bit			
Format :	HEX			
Settings : Please refer to the description of P6-02.				

P6-63	PDAT31	PATH# 31Data		Address: 067EH 067FH
	Operational Interface :	Panel / Software	Communication	Related Section: 7.10
Default :	0			
Control Mode :	PR			
Unit :	-			
Range :	-2147483648 ~ +2147483647			
Data Size :	32bit			
Format :	DEC			
Settings : Please refer to the description of P6-03				

P6-64	PDEF32	PATH# 32Definition		Address: 0680H 0681H
	Operational Interface :	Panel / Software	Communication	Related Section: 7.10
Default :	0x00000000			
Control Mode :	PR			
Unit :	-			
Range :	0x00000000 ~ 0xFFFFFFFF			
Data Size :	32bit			
Format :	HEX			

Settings : Please refer to the description of P6-02.

P6-65	PDAT32	PATH# 32Data		Address: 0682H 0683H
	Operational Interface :	Panel / Software	Communication	Related Section: 7.10
Default :	0			
Control Mode :	PR			
Unit :	-			
Range :	-2147483648 ~ +2147483647			
Data Size :	32bit			
Format :	DEC			

Settings : Please refer to the description of P6-03.

P6-66	PDEF33	PATH# 33Definition		Address: 0684H 0685H
	Operational Interface :	Panel / Software	Communication	Related Section: 7.10
	Default :	0x00000000		
	Control Mode :	PR		
	Unit :	-		
	Range :	0x00000000 ~ 0xFFFFFFFF		
	Data Size :	32bit		
	Format :	HEX		
	Settings : Please refer to the description of P6-02.			

P6-67	PDAT33	PATH# 33Data		Address: 0686H 0687H
	Operational Interface :	Panel / Software	Communication	Related Section: 7.10
	Default :	0		
	Control Mode :	PR		
	Unit :	-		
	Range :	-2147483648 ~ +2147483647		
	Data Size :	32bit		
	Format :	DEC		
	Settings : Please refer to the description of P6-03.			

P6-68	PDEF34	PATH# 34Definition		Address: 0688H 0689H
	Operational Interface :	Panel / Software	Communication	Related Section: 7.10
Default :	0x00000000			
Control Mode :	PR			
Unit :	-			
Range :	0x00000000 ~ 0xFFFFFFFF			
Data Size :	32bit			
Format :	HEX			

Settings : Please refer to the description of P6-02.

P6-69	PDAT34	PATH# 34Data		Address: 068AH 068BH
	Operational Interface :	Panel / Software	Communication	Related Section: 7.10
Default :	0			
Control Mode :	PR			
Unit :	-			
Range :	-2147483648 ~ +2147483647			
Data Size :	32bit			
Format :	DEC			

Settings : Please refer to the description of P6-03.

P6-70	PDEF35	PATH# 35Definition		Address: 068CH 068DH
	Operational Interface :	Panel / Software	Communication	Related Section: 7.10
	Default :	0x00000000		
	Control Mode :	PR		
	Unit :	-		
	Range :	0x00000000 ~ 0xFFFFFFFF		
	Data Size :	32bit		
	Format :	HEX		
	Settings : Please refer to the description of P6-02.			

P6-71	PDAT35	PATH# 35Data		Address: 068EH 068FH
	Operational Interface :	Panel / Software	Communication	Related Section: 7.10
	Default :	0		
	Control Mode :	PR		
	Unit :	-		
	Range :	-2147483648 ~ +2147483647		
	Data Size :	32bit		
	Format :	DEC		
	Settings : Please refer to the description of P6-03.			

P6-72	PDEF36	PATH# 36Definition		Address: 0690H 0691H
	Operational Interface :	Panel / Software	Communication	Related Section: 7.10
Default :	0x00000000			
Control Mode :	PR			
Unit :	-			
Range :	0x00000000 ~ 0xFFFFFFFF			
Data Size :	32bit			
Format :	HEX			

Settings : Please refer to the description of P6-02.

P6-73	PDAT36	PATH# 36Data		Address: 0692H 0693H
	Operational Interface :	Panel / Software	Communication	Related Section: 7.10
Default :	0			
Control Mode :	PR			
Unit :	-			
Range :	-2147483648 ~ +2147483647			
Data Size :	32bit			
Format :	DEC			

Settings : Please refer to the description of P6-03.

P6-74	PDEF37	PATH# 37Definition		Address: 0694H 0695H
	Operational Interface :	Panel / Software	Communication	Related Section: 7.10
	Default :	0x00000000		
	Control Mode :	PR		
	Unit :	-		
	Range :	0x00000000 ~ 0xFFFFFFFF		
	Data Size :	32bit		
	Format :	HEX		
	Settings : Please refer to the description of P6-02.			

P6-75	PDAT37	PATH# 37Data		Address: 0696H 0697H
	Operational Interface :	Panel / Software	Communication	Related Section: 7.10
	Default :	0		
	Control Mode :	PR		
	Unit :	-		
	Range :	-2147483648 ~ +2147483647		
	Data Size :	32bit		
	Format :	DEC		
	Settings : Please refer to the description of P6-03.			

P6-76	PDEF38 PATH# 38Definition		Address: 0698H 0699H
	Operational Interface :	Panel / Software	Communication
Default :	0x00000000		
Control Mode :	PR		
Unit :	-		
Range :	0x00000000 ~ 0xFFFFFFFF		
Data Size :	32bit		
Format :	HEX		
Settings :	Please refer to the description of P6-02.		

P6-77	PDAT38 PATH# 38Data		Address: 069AH 069BH
	Operational Interface :	Panel / Software	Communication
Default :	0		
Control Mode :	PR		
Unit :	-		
Range :	-2147483648 ~ +2147483647		
Data Size :	32bit		
Format :	DEC		
Settings :	Please refer to the description of P6-03.		

P6-78	PDEF39	PATH# 39	Definition	Address: 069CH 069DH
	Operational Interface :	Panel / Software	Communication	Related Section: 7.10
	Default :	0x00000000		
	Control Mode :	PR		
	Unit :	-		
	Range :	0x00000000 ~ 0xFFFFFFFF		
	Data Size :	32bit		
	Format :	HEX		
	Settings :	Please refer to the description of P6-02.		

P6-79	PDAT39	PATH# 39	Data	Address: 069EH 069FH
	Operational Interface :	Panel / Software	Communication	Related Section: 7.10
	Default :	0		
	Control Mode :	PR		
	Unit :	-		
	Range :	-2147483648 ~ +2147483647		
	Data Size :	32bit		
	Format :	DEC		
	Settings :	Please refer to the description of P6-03.		

P6-80	PDEF40 PATH# 40Definition		Address: 06A0H 06A1H
	Operational Interface :	Panel / Software	Communication
Default :	0x00000000		
Control Mode :	PR		
Unit :	-		
Range :	0x00000000 ~ 0xFFFFFFFF		
Data Size :	32bit		
Format :	HEX		
Settings :	Please refer to the description of P6-02.		

P6-81	PDAT40 PATH# 40Data		Address: 06A2H 06A3H
	Operational Interface :	Panel / Software	Communication
Default :	0		
Control Mode :	PR		
Unit :	-		
Range :	-2147483648 ~ +2147483647		
Data Size :	32bit		
Format :	DEC		
Settings :	Please refer to the description of P6-03.		

P6-82	PDEF41	PATH# 41Definition		Address: 06A4H 06A5H
	Operational Interface :	Panel / Software	Communication	Related Section: 7.10
	Default :	0x00000000		
	Control Mode :	PR		
	Unit :	-		
	Range :	0x00000000 ~ 0xFFFFFFFF		
	Data Size :	32bit		
	Format :	HEX		

Settings : Please refer to the description of P6-02.

P6-83	PDAT41	PATH# 41Data		Address: 06A6H 06A7H
	Operational Interface :	Panel / Software	Communication	Related Section: 7.10
	Default :	0		
	Control Mode :	PR		
	Unit :	-		
	Range :	-2147483648 ~ +2147483647		
	Data Size :	32bit		
	Format :	DEC		

Settings : Please refer to the description of P6-03.

P6-84	PDEF42	PATH# 42Definition		Address: 06A8H 06A9H
	Operational Interface :	Panel / Software	Communication	Related Section: 7.10
Default :	0x00000000			
Control Mode :	PR			
Unit :	-			
Range :	0x00000000 ~ 0xFFFFFFFF			
Data Size :	32bit			
Format :	HEX			
Settings : Please refer to the description of P6-02.				

P6-85	PDAT42	PATH# 42Data		Address: 06AAH 06ABH
	Operational Interface :	Panel / Software	Communication	Related Section: 7.10
Default :	0			
Control Mode :	PR			
Unit :	-			
Range :	-2147483648 ~ +2147483647			
Data Size :	32bit			
Format :	DEC			
Settings : Please refer to the description of P6-03.				

P6-86	PDEF43	PATH# 43Definition		Address: 06ACH 06ADH
	Operational Interface :	Panel / Software	Communication	Related Section: 7.10
	Default :	0x00000000		
	Control Mode :	PR		
	Unit :	-		
	Range :	0x00000000 ~ 0xFFFFFFFF		
	Data Size :	32bit		
	Format :	HEX		

Settings : Please refer to the description of P6-02.

P6-87	PDAT43	PATH# 43Data		Address: 06AEH 06AFH
	Operational Interface :	Panel / Software	Communication	Related Section: 7.10
	Default :	0		
	Control Mode :	PR		
	Unit :	-		
	Range :	-2147483648 ~ +2147483647		
	Data Size :	32bit		
	Format :	DEC		

Settings : Please refer to the description of P6-03.

P6-88	PDEF44	PATH# 44Definition		Address: 06B0H 06B1H
	Operational Interface :	Panel / Software	Communication	Related Section: 7.10
Default :	0x00000000			
Control Mode :	PR			
Unit :	-			
Range :	0x00000000 ~ 0xFFFFFFFF			
Data Size :	32bit			
Format :	HEX			

Settings : Please refer to the description of P6-02.

P6-89	PDAT44	PATH# 44Data		Address: 06B2H 06B3H
	Operational Interface :	Panel / Software	Communication	Related SectionL 7.10
Default :	0			
Control Mode :	PR			
Unit :	-			
Range :	-2147483648 ~ +2147483647			
Data Size :	32bit			
Format :	DEC			

Settings : Please refer to the description of P6-03.

P6-90	PDEF45	PATH# 45Definition		Address: 06B4H 06B5H
	Operational Interface :	Panel / Software	Communication	Related Section: 7.10
	Default :	0x00000000		
	Control Mode :	PR		
	Unit :	-		
	Range :	0x00000000 ~ 0xFFFFFFFF		
	Data Size :	32bit		
	Format :	HEX		
	Settings : Please refer to the description of P6-02.			

P6-91	PDAT45	PATH# 45Data		Address: 06B6H 06B7H
	Operational Interface :	Panel / Software	Communication	Related Section: 7.10
	Default :	0		
	Control Mode :	PR		
	Unit :	-		
	Range :	-2147483648 ~ +2147483647		
	Data Size :	32bit		
	Format :	DEC		
	Settings : Please refer to the description of P6-03.			

P6-92	PDEF46	PATH# 46Definition		Address: 06B8H 06B9H
	Operational Interface :	Panel / Software	Communication	Related Section: 7.10
Default :	0x00000000			
Control Mode :	PR			
Unit :	-			
Range :	0x00000000 ~ 0xFFFFFFFF			
Data Size :	32bit			
Format :	HEX			

Settings : Please refer to the description of P6-02.

P6-93	PDAT46	PATH# 46Data		Address: 06BAH 06BBH
	Operational Interface :	Panel / Software	Communication	Related Section: 7.10
Default :	0			
Control Mode :	PR			
Unit :	-			
Range :	-2147483648 ~ +2147483647			
Data Size :	32bit			
Format :	DEC			

Settings : Please refer to the description of P6-03.

P6-94	PDEF47	PATH# 47	Definition	Address: 06BCH 06BDH
	Operational Interface :	Panel / Software	Communication	Related Section: 7.10
	Default :	0x00000000		
	Control Mode :	PR		
	Unit :	-		
	Range :	0x00000000 ~ 0xFFFFFFFF		
	Data Size :	32bit		
	Format :	HEX		
	Settings :	Please refer to the description of P6-02.		

P6-95	PDAT47	PATH# 47	Data	Address: 06BEH 06BFH
	Operational Interface :	Panel / Software	Communication	Related Section: 7.10
	Default :	0		
	Control Mode :	PR		
	Unit :	-		
	Range :	-2147483648 ~ +2147483647		
	Data Size :	32bit		
	Format :	DEC		
	Settings :	Please refer to the description of P6-03.		

P6-96	PDEF48	PATH# 48	Definition	Address: 06C0H 06C1H
	Operational Interface :	Panel / Software	Communication	Related Section: 7.10
	Default :	0x00000000		
	Control Mode :	PR		
	Unit :	-		
	Range :	0x00000000 ~ 0xFFFFFFFF		
	Data Size :	32bit		
	Format :	HEX		
	Settings :	Please refer to the description of P6-02.		

P6-97	PDAT48	PATH# 48	Data	Address: 06C2H 06C3H
	Operational Interface :	Panel / Software	Communication	Related Section: 7.10
	Default :	0		
	Control Mode :	PR		
	Unit :	-		
	Range :	-2147483648 ~ +2147483647		
	Data Size :	32bit		
	Format :	DEC		
	Settings :	Please refer to the description of P6-03.		

P6-98	PDEF49	PATH# 49	Definition	Address: 06C4H 06C5H
	Operational Interface :	Panel / Software	Communication	Related Section: 7.10
	Default :	0x00000000		
	Control Mode :	PR		
	Unit :	-		
	Range :	0x00000000 ~ 0xFFFFFFFF		
	Data Size :	32bit		
	Format :	HEX		
	Settings :	Please refer to the description of P6-02.		

P6-99	PDAT49	PATH# 49	Data	Address: 06C6H 06C7H
	Operational Interface :	Panel / Software	Communication	Related Section: 7.10
	Default :	0		
	Control Mode :	PR		
	Unit :	-		
	Range :	-2147483648 ~ +2147483647		
	Data Size :	32bit		
	Format :	DEC		
	Settings :	Please refer to the description of P6-03.		

P7-xx PR Parameters (Please refer to Chapter 7 for detailed setting)

P7-00	PDEF50	PATH# 50 Definition	Address: 0700H 0701H
Operational Interface :	Panel / Software	Communication	Related Section: 7.10
Default :	0x00000000		
Control Mode :	PR		
Unit :	-		
Range :	0x00000000 ~ 0xFFFFFFFF		
Data Size :	32bit		
Format :	HEX		
Settings :	Please refer to the description of P6-02		
Note :	PATH (procedure)		

P7-01	PDAT50	PATH# 50 Data	Address: 0702H 0703H
Operational Interface :	Panel / Software	Communication	Related Section: 7.10
Default :	0		
Control Mode :	PR		
Unit :	-		
Range :	-2147483648 ~ +2147483647		
Data Size :	32bit		
Format :	DEC		
Settings :	Please refer to the description of P6-03.		

P7-02	PDEF51	PATH# 51 Definition	Address: 0704H 0705H
	Operational Interface :	Panel / Software	Communication
	Default :	0x00000000	
	Control Mode :	PR	
	Unit :	-	
	Range :	0x00000000 ~ 0xFFFFFFFF	
	Data Size :	32bit	
	Format :	HEX	
	Settings :	Please refer to the description of P6-02.	

P7-03	PDAT51	PATH# 51 Data	Address: 0706H 0707H
	Operational Interface :	Panel / Software	Communication
	Default :	0	
	Control Mode :	PR	
	Unit :	-	
	Range :	-2147483648 ~ +2147483647	
	Data Size :	32bit	
	Format :	DEC	
	Settings :	Please refer to the description of P6-03.	

P7-04	PDEF52	PATH# 52 Definition		Address: 0708H 0709H
Operational Interface :	Panel / Software	Communication	Related Section: 7.10	
Default :	0x00000000			
Control Mode :	PR			
Unit :	-			
Range :	0x00000000 ~ 0xFFFFFFFF			
Data Size :	32bit			
Format :	HEX			
Settings :	Please refer to the description of P6-02.			

P7-05	PDAT52	PATH# 52 Data		Address: 070AH 070BH
Operational Interface :	Panel / Software	Communication	Related Section: 7.10	
Default :	0			
Control Mode :	PR			
Unit :	-			
Range :	-2147483648 ~ +2147483647			
Data Size :	32bit			
Format :	DEC			
Settings :	Please refer to the description of P6-03.			

P7-06	PDEF53	PATH# 53 Definition		Address: 070CH 070DH
Operational Interface :		Panel / Software	Communication	Related Section: 7.10
Default :		0x00000000		
Control Mode :		PR		
Unit :		-		
Range :		0x00000000 ~ 0xFFFFFFFF		
Data Size :		32bit		
Format :		HEX		
Settings : Please refer to the description of P6-02.				

P7-07	PDAT53	PATH# 53 Data		Address: 070EH 070FH
Operational Interface :		Panel / Software	Communication	Related Section: 7.10
Default :		0		
Control Mode :		PR		
Unit :		-		
Range :		-2147483648 ~ +2147483647		
Data Size :		32bit		
Format :		DEC		
Settings : Please refer to the description of P6-03.				

P7-08	PDEF54	PATH# 54 Definition		Address: 0710H 0711H
	Operational Interface :	Panel / Software	Communication	Related Section: 7.10
Default :	0x00000000			
Control Mode :	PR			
Unit :	-			
Range :	0x00000000 ~ 0xFFFFFFFF			
Data Size :	32bit			
Format :	HEX			

Settings : Please refer to the description of P6-02.

P7-09	PDAT54	PATH# 54 Data		Address: 0712H 0713H
	Operational Interface :	Panel / Software	Communication	Related Section: 7.10
Default :	0			
Control Mode :	PR			
Unit :	-			
Range :	-2147483648 ~ +2147483647			
Data Size :	32bit			
Format :	DEC			

Settings : Please refer to the description of P6-03.

P7-10	PDEF55	PATH# 55 Definition	Address: 0714H 0715H
	Operational Interface :	Panel / Software	Communication
	Default :	0x00000000	
	Control Mode :	PR	
	Unit :	-	
	Range :	0x00000000 ~ 0xFFFFFFFF	
	Data Size :	32bit	
	Format :	HEX	
	Settings :	Please refer to the description of P6-02.	
			Related Section: 7.10

P7-11	PDAT55	PATH# 55 Data	Address: 0716H 0717H
	Operational Interface :	Panel / Software	Communication
	Default :	0	
	Control Mode :	PR	
	Unit :	-	
	Range :	-2147483648 ~ +2147483647	
	Data Size :	32bit	
	Format :	DEC	
	Settings :	Please refer to the description of P6-03.	
			Related Section: 7.10

P7-12	PDEF56	PATH# 56 Definition		Address: 0718H 0719H
	Operational Interface :	Panel / Software	Communication	Related Section: 7.10
Default :	0x00000000			
Control Mode :	PR			
Unit :	-			
Range :	0x00000000 ~ 0xFFFFFFFF			
Data Size :	32bit			
Format :	HEX			
Settings : Please refer to the description of P6-02.				

P7-13	PDAT56	PATH# 56 Data		Address: 071AH 071BH
	Operational Interface :	Panel / Software	Communication	Related Section: 7.10
Default :	0			
Control Mode :	PR			
Unit :	-			
Range :	-2147483648 ~ +2147483647			
Data Size :	32bit			
Format :	DEC			
Settings : Please refer to the description of P6-03.				

P7-14	PDEF57	PATH# 57 Definition	Address: 071CH 071DH
	Operational Interface :	Panel / Software	Communication
	Default :	0x00000000	
	Control Mode :	PR	
	Unit :	-	
	Range :	0x00000000 ~ 0xFFFFFFFF	
	Data Size :	32bit	
	Format :	HEX	
	Settings :	Please refer to the description of P6-02.	

P7-15	PDAT57	PATH# 57 Data	Address: 071EH 071FH
	Operational Interface :	Panel / Software	Communication
	Default :	0	
	Control Mode :	PR	
	Unit :	-	
	Range :	-2147483648 ~ +2147483647	
	Data Size :	32bit	
	Format :	DEC	
	Settings :	Please refer to the description of P6-03.	

P7-16	PDEF58	PATH# 58 Definition		Address: 0720H 0721H
	Operational Interface :	Panel / Software	Communication	Related Section: 7.10
Default :	0x00000000			
Control Mode :	PR			
Unit :	-			
Range :	0x00000000 ~ 0xFFFFFFFF			
Data Size :	32bit			
Format :	HEX			

Settings : Please refer to the description of P6-02.

P7-17	PDAT58	PATH# 58 Data		Address: 0722H 0723H
	Operational Interface :	Panel / Software	Communication	Related Section: 7.10
Default :	0			
Control Mode :	PR			
Unit :	-			
Range :	-2147483648 ~ +2147483647			
Data Size :	32bit			
Format :	DEC			

Settings : Please refer to the description of P6-03.

P7-18	PDEF59	PATH# 59 Definition	Address: 0724H 0725H
	Operational Interface :	Panel / Software	Communication
	Default :	0x00000000	
	Control Mode :	PR	
	Unit :	-	
	Range :	0x00000000 ~ 0xFFFFFFFF	
	Data Size :	32bit	
	Format :	HEX	
	Settings :	Please refer to the description of P6-02.	

P7-19	PDAT59	PATH# 59 Data	Address: 0726H 0727H
	Operational Interface :	Panel / Software	Communication
	Default :	0	
	Control Mode :	PR	
	Unit :	-	
	Range :	-2147483648 ~ +2147483647	
	Data Size :	32bit	
	Format :	DEC	
	Settings :	Please refer to the description of P6-03.	

P7-20	PDEF60	PATH# 60 Definition	Address: 0728H 0729H
	Operational Interface :	Panel / Software	Communication
	Default :	0x00000000	
	Control Mode :	PR	
	Unit :	-	
	Range :	0x00000000 ~ 0xFFFFFFFF	
	Data Size :	32bit	
	Format :	HEX	
	Settings :	Please refer to the description of P6-02.	

P7-21	PDAT60	PATH# 60 Data	Address: 072AH 072BH
	Operational Interface :	Panel / Software	Communication
	Default :	0	
	Control Mode :	PR	
	Unit :	-	
	Range :	-2147483648 ~ +2147483647	
	Data Size :	32bit	
	Format :	DEC	
	Settings :	Please refer to the description of P6-03.	

P7-22	PDEF61	PATH# 61 Definition		Address: 072CH 072DH
	Operational Interface :	Panel / Software	Communication	Related Section: 7.10
Default :	0x00000000			
Control Mode :	PR			
Unit :	-			
Range :	0x00000000 ~ 0xFFFFFFFF			
Data Size :	32bit			
Format :	HEX			
Settings : Please refer to the description of P6-02.				

P7-23	PDAT61	PATH# 61 Data		Address: 072EH 072FH
	Operational Interface :	Panel / Software	Communication	Related Section: 7.10
Default :	0			
Control Mode :	PR			
Unit :	-			
Range :	-2147483648 ~ +2147483647			
Data Size :	32bit			
Format :	DEC			
Settings : Please refer to the description of P6-03.				

P7-24	PDEF62	PATH# 62 Definition		Address: 0730H 0731H
	Operational Interface :	Panel / Software	Communication	Related Section: 7.10
	Default :	0x00000000		
	Control Mode :	PR		
	Unit :	-		
	Range :	0x00000000 ~ 0xFFFFFFFF		
	Data Size :	32bit		
	Format :	HEX		
	Settings :	Please refer to the description of P6-02.		

P7-25	PDAT62	PATH# 62 Data		Address: 0732H 0733H
	Operational Interface :	Panel / Software	Communication	Related Section: 7.10
	Default :	0		
	Control Mode :	PR		
	Unit :	-		
	Range :	-2147483648 ~ +2147483647		
	Data Size :	32bit		
	Format :	DEC		
	Settings :	Please refer to the description of P6-03.		

P7-26	PDEF63	PATH# 63 Definition		Address: 0734H 0735H
	Operational Interface :	Panel / Software	Communication	Related Section: 7.10
	Default :	0x00000000		
	Control Mode :	PR		
	Unit :	-		
	Range :	0x00000000 ~ 0xFFFFFFFF		
	Data Size :	32bit		
	Format :	HEX		
Settings : Please refer to the description of P6-02.				

P7-27	PDAT63	PATH# 63 Data		Address: 0736H 0737H
	Operational Interface :	Panel / Software	Communication	Related Section: 7.10
	Default :	0		
	Control Mode :	PR		
	Unit :	-		
	Range :	-2147483648 ~ +2147483647		
	Data Size :	32bit		
	Format :	DEC		
Settings : Please refer to the description of P6-03.				

PM-xx Motor Parameters

PM-00	Motor Type		Address:
Operational Interface :	Panel / Software	Communication	Related Section: -
Default :	0		
Control Mode :	ALL		
Unit :	N/A		
Range :	0~3		
Data Size :	16bit		
Format :	DEC		
Settings : 0 = Surface-mounted permanent magnet synchronous rotary motor (SPM); 2 = Permanent magnet synchronous linear motor (LM)			

PM-01	Automatic Identification of Motor Parameter		Address:
Applicable motor type :	IM		Related Section: -
Operational Interface :	Panel / Software	Communication	
Default :	0		
Unit :			
Range :	0~1		
Data Size :	16bit		
Format :	DEC		
Settings : 0 = disable the function 1 = enable the function			

PM-02	Confirmation of Motor Parameter		Address:
Applicable motor type :	ALL		Related Section: -
Operational Interface :	Panel / Software	Communication	
Default :	0		
Unit :			
Range :	0~1		
Data Size :	16bit		
Format :	DEC		
Settings :	0 = Motor parameter is invalid. 1 = Motor parameter is valid. When the drive is Servo On, if this parameter is disabled, an alarm will occur. When Automatic Identification of Motor Parameter is completed, this bit is On automatically. Or, users can self-define the motor parameter and enable this function.		

PM-03	Encoder Type		Address:
Applicable motor type :	ALL		Related Section: -
Operational Interface :	Panel / Software	Communication	
Default :	0x0100		
Unit :			
Range :	0 x0000~0x1311		
Data Size :	16bit		
Format :	HEX		

Settings :

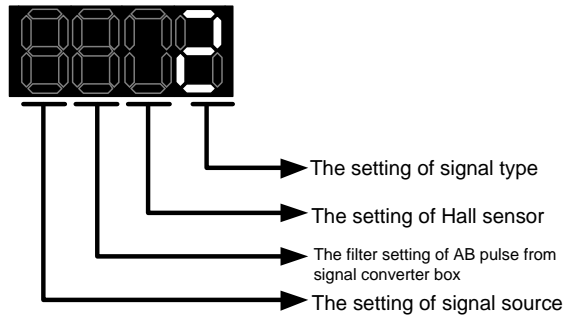

The setting of signal type:

0 = Square wave digital signal

1 = Sinusoid analog signal

The setting of Hall sensor:

0 = without Hall sensor

1 = with Hall sensor

When selecting the setting without Hall sensor, the motor will jitter to detect magnetic pole when servo On for the first time. (it cannot work on Z axis with no spring or without balance.)

The filter setting of AB pulse from signal converter box:

0 = BYPASS

1 = 16M

2 = 8M

3 = 3M

Take pulse width 16Mhz(62.5ns) as the example,

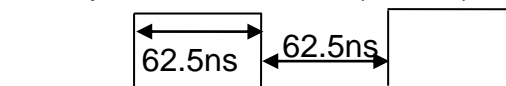

When the width of single-phase pulse is smaller than 62.5ns, the signal will be filtered.

The setting of signal source:

0 = comes from CN2

1 = comes from CN5

PM-04	Encoder Resolution		Address:
Applicable motor type :	ALL		Related Section: -
Operational Interface :	Panel / Software	Communication	
Default :	2500		
Unit :	Permanet magnet synchronous rotary motor: <i>pulse/ rev</i> (square wave digital siganl) <i>periods/ rev</i> (sinusoid analog signal) Permanet magnet synchronous linear motor: $10^{-5} \mu m/ pulse$ (square wave digital siganl) $10^{-3} \mu m/ period$ (sinusoid analog signal)		
Range :	64~ $2^{29} - 1$		
Data Size :	32bit		
Format :	DEC		
Settings :			

PM-05	The Interpolation of Signal Converter Box		Address:
Applicable motor type :	ALL		Related Section: -
Operational Interface :	Panel / Software	Communication	
Default :	11		
Unit :			
Range :	4~11		
Data Size :	16bit		
Format :	DEC		
Settings :			

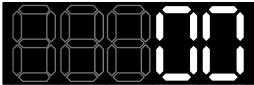
PM-06	UVW Phase Sequence and Hall Sensor		Address:
	Applicable motor type :	ALL	
	Operational Interface :	Panel / Software	Communication
	Default :	00	
	Unit :		
	Range :	0 ~0x11	
	Data Size :	16bit	
	Format :	HEX	
	Settings :		

Related Section: -

Settings :

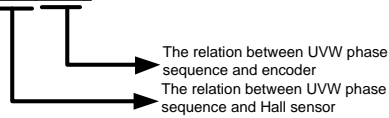
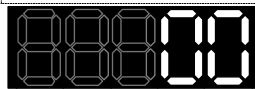

The relation between UVW phase sequence and encoder

0 = The scale direction and phase sequence of each U/V/W is the same (see diagram below)

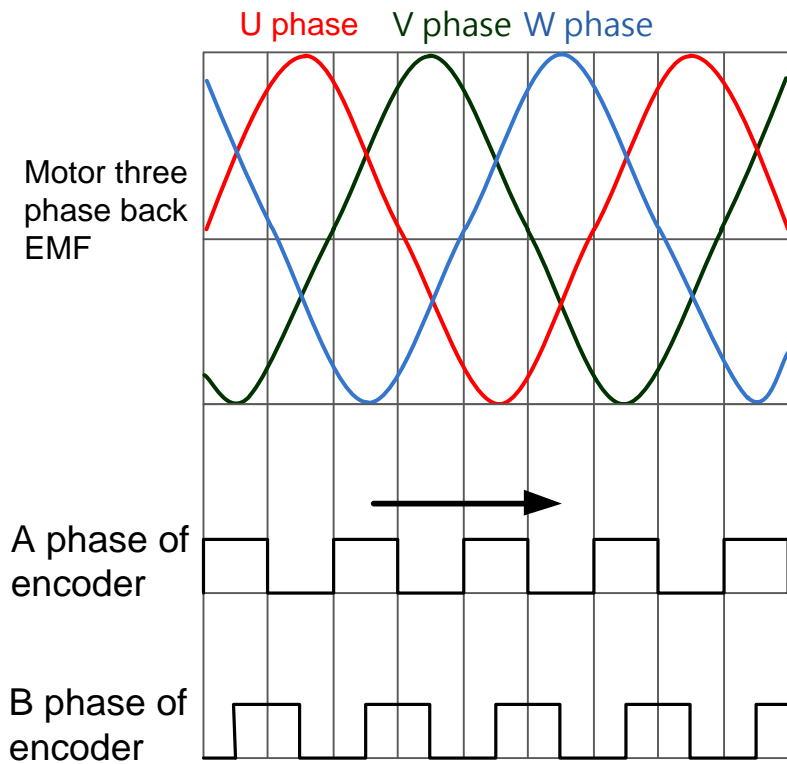

1 = The scale direction is opposite to UVW phase sequence

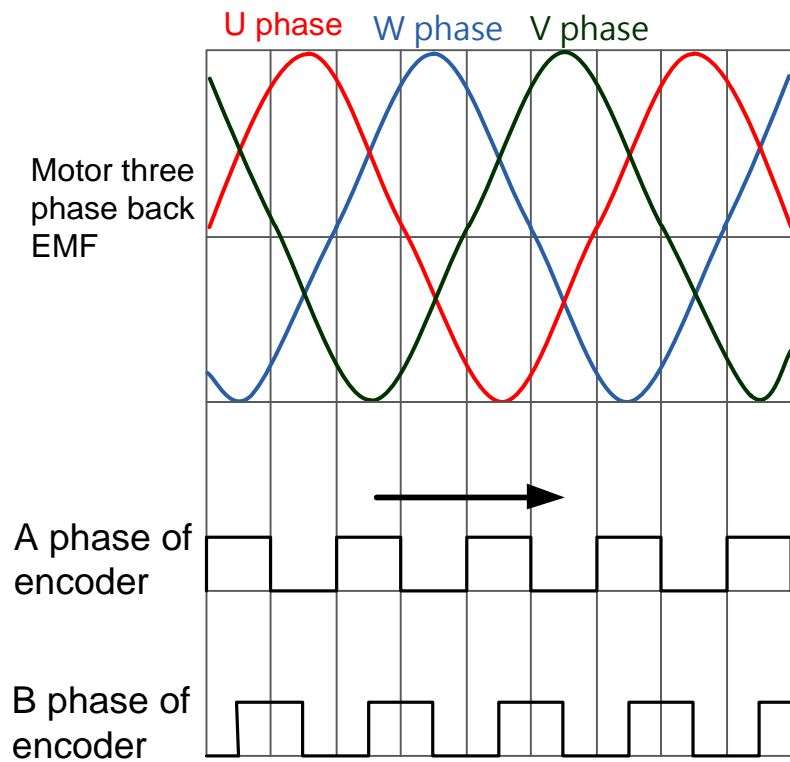

The relation between UVW phase sequence and Hall sensor
 0: UVW phase sequence of Hall sensor is the same as the motor's.

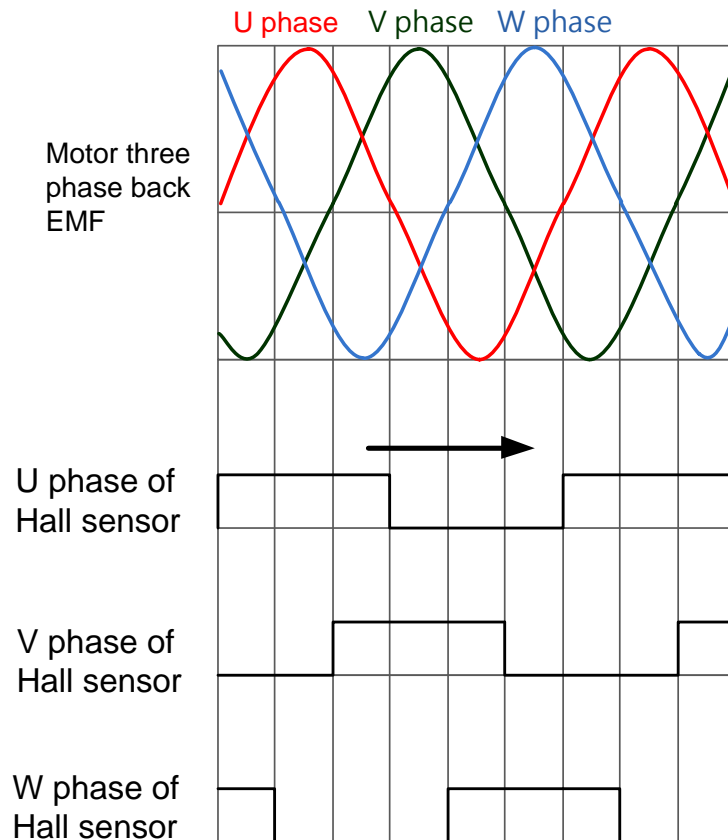

1: UVW phase sequence of Hall sensor is opposite to the motor's

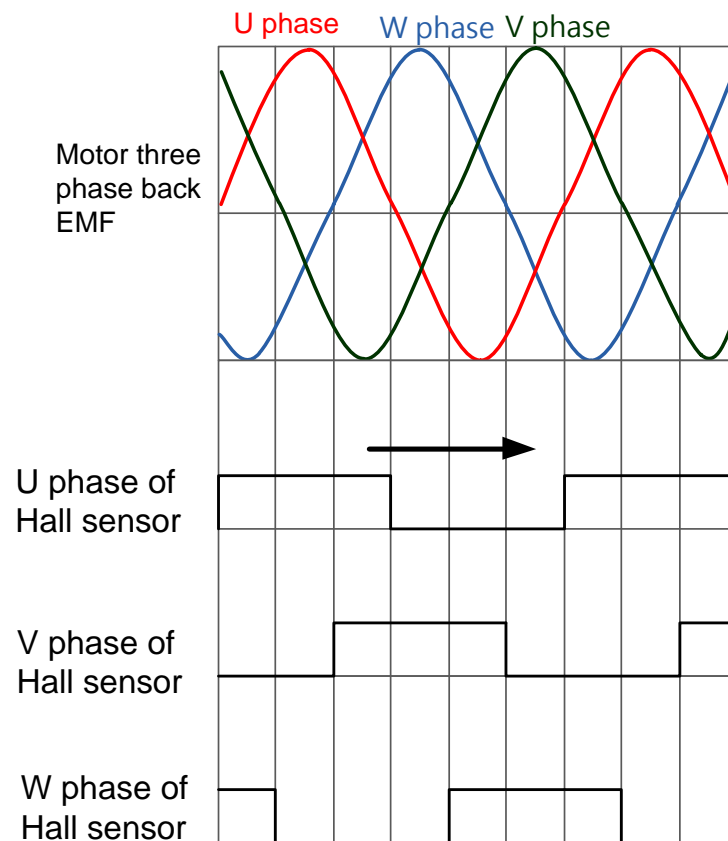

PM-07	Offset Angle of Hall Sensor		Address:
Applicable motor type :	ALL		Related Section: -
Operational Interface :	Panel / Software	Communication	
Default :	0		
Unit :	0.1° (electrical angle)		
Range :	0 ~3600		
Data Size :	16bit		
Format :	DEC		

Settings :

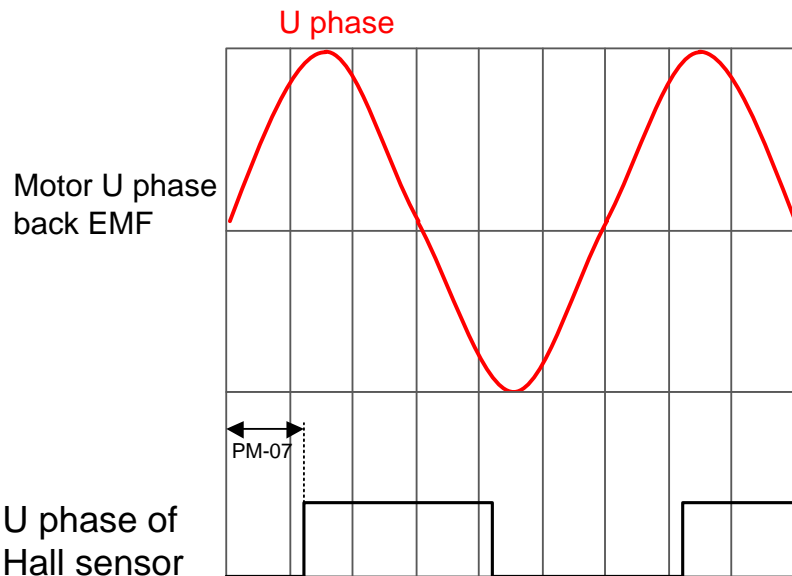

When hysteresis is caused by different moving direction of motor, the original point of U phase of Hall sensor will base on the center angle of hysteresis. (please refer to PM-08 for the description of hysteresis).

PM-08	Hysteresis Width of Hall Sensor Moving Back and Forth		Address:
	Applicable motor type :	ALL	
	Operational Interface :	Panel / Software	Communication
	Default :	0	
	Unit :	0.1°(electrical angle)	
	Range :	0 ~3600	
	Data Size :	16bit	
	Format :	DEC	
	Related Section: -		

Settings :

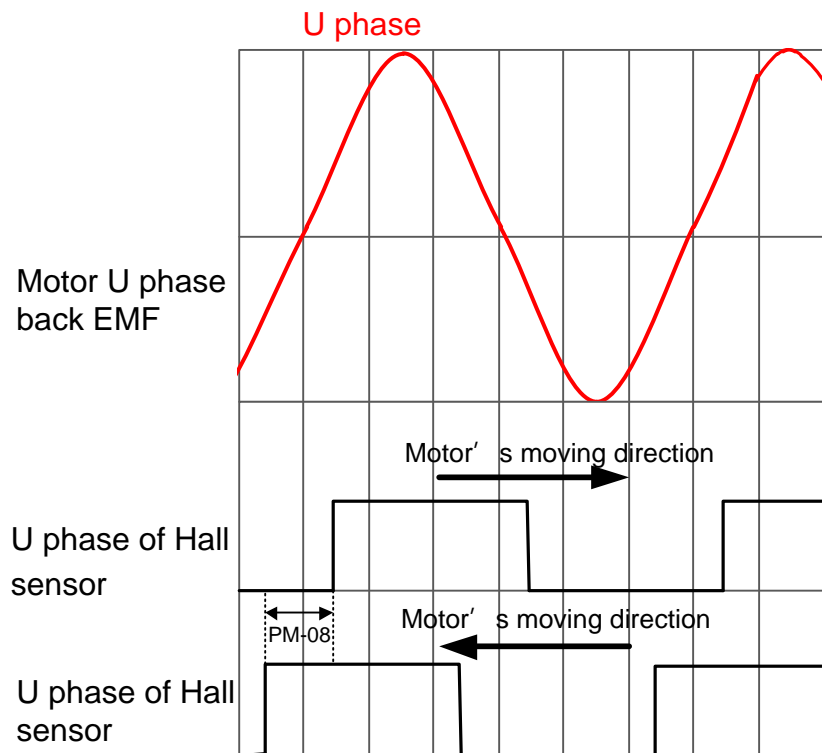

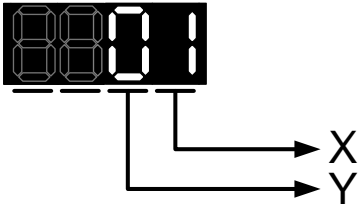
PM-09	Correction of Electrical Angle When Reached Z Axis		Address:
Applicable motor type :	ALL		Related Section: -
Operational Interface :	Panel / Software	Communication	
Default :	0x11		
Unit :			
Range :	0x00 ~ 0x11		
Data Size :	16bit		
Format :	HEX		
Settings :			

X:
 0: Disable the function of adjusting magnetic field via Z phase
 1: Enable the function of adjusting magnetic field via Z phase
 Y:
 0: Disable the function. Use hall sensor to see if motor magnetic field is deviated.
 1: Enable the function. Use hall sensor to see if motor magnetic field is deviated.

PM-10	Offset Angle of Z Signal		Address:
Applicable motor type :	ALL		Related Section: -
Operational Interface :	Panel / Software	Communication	
Default :	0		
Unit :	0.1°(electrical angle)		
Range :	0 ~3600		
Data Size :	16bit		
Format :	DEC		
Settings :			

PM-11	Current of Magnetic Field Detection When Power On		Address:
	Applicable motor type :	ALL	
Operational Interface :	Panel / Software	Communication	
Default :	100		
Unit :	%		
Range :	0 ~300		
Data Size :	16bit		
Format :	DEC		

Settings : When PM-03.Y = 0, motor will detect motor magnetic field automatically when applying to the power. The amount of current is the same as the setting value. Followings are the adjusting condition:

1. When the motor friction is too excessive, it easily cause AL.052 duing to the wrong detection of magnetic field. Increase the value can reduce the occurrence of Alarm 52. °
2. During the magnetic field detection, if the vibration is too excessive, reduce the value of this parameter could reduce the vibration.

※Please note that the magnetic field detection does not work if Z axis has no spring or balance.

PM-12	Condition of Magnetic Field Detection When Power On		Address:
	Applicable motor type :	ALL	
Operational Interface :	Panel / Software	Communication	
Default :	100		
Unit :	N/A		
Range :	0X00 ~ 0XFF		
Data Size :	16bit		
Format :	HEX		

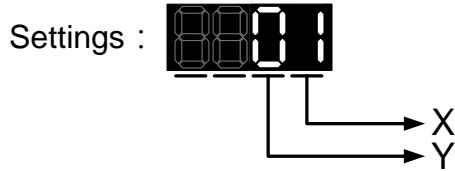

X:

If the moving of motor magnetic field is more than $X \cdot 0.25$ degrees, the condition is established.

Y:

If the motor magnetic field should move more than $Y \cdot 10$ degrees, the condition is established.

When condition X and Y are both established, the detection of motor magnetic field succeed.

When condition X or Y is not established, it will detect the magnetic field by different angle. When the detection is failed up to four times, AL.052 will occur.

PM-13	Reserved	Address:
--------------	-----------------	-----------------

PM-14	Reserved	Address:
--------------	-----------------	-----------------

PM-15	Proportional Gain of Current Loop		Address:
Applicable motor type :	ALL		Related Section: -
Operational Interface :	Panel / Software	Communication	
Default :	0		
Unit :	0.001		
Range :	SPM, IPM: 0~1023000 LM: 0~16383000 IM: 0~32767000		
Data Size :	32bit		
Format :	DEC		

Settings :

PM-16	Integral Gain of Current Loop		Address:
Applicable motor type :	ALL		Related Section: -
Operational Interface :	Panel / Software	Communication	
Default :	0		
Unit :			
Range :	SPM, IPM: 0~511 LM: 0~32767 IM: 0~4095		
Data Size :	16bit		
Format :	DEC		
Settings :			

PM-17	Reserved	Address:

PM-18	Reserved	Address:

PM-19	Overload Gain (Temperature Rises)		Address:
Applicable motor type :	ALL		Related Section: -
Operational Interface :	Panel / Software	Communication	
Default :	100		
Unit :	%		
Range :	15~600		
Data Size :	16bit		
Format :	DEC		
Settings :			

Settings :

Load Proportion	Operation Time
0%	-12sec x PM-20
20%	-12.3sec x PM-20
40%	-13.6sec x PM-20
60%	-16.3sec x PM-20
80%	-22.6sec x PM-20
100%	N/A
120%	26.38sec x PM-19
140%	35.2sec x PM-19
160%	17.6sec x PM-19
180%	11.2sec x PM-19
200%	8sec x PM-19
220%	6.1sec x PM-19
240%	4.8sec x PM-19
260%	3.9sec x PM-19
280%	3.3sec x PM-19
300%	2.8sec x PM-19
320%	2.5sec x PM-19
340%	2.2sec x PM-19
360%	2.0sec x PM-19
380%	1.8sec x PM-19
400%	1.6sec x PM-19
420%	1.4sec x PM-19
440%	1.3sec x PM-19
460%	1.2sec x PM-19
480%	1.1sec x PM-19
500%	1.0sec x PM-19

Operation time indicates the time that protection level turns to overload level from the normal one. When it turns to overload level, the function of overload protection will be triggered. Following is the example with 200% of current:

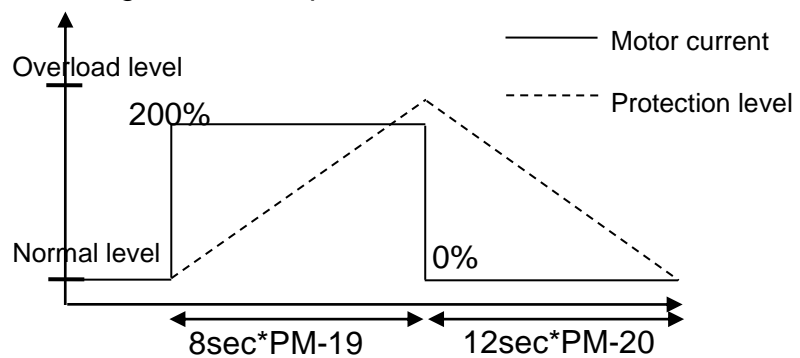

From the above figure, when motor outputs 200% of current, the protection level will turn to overload level from the normal one in 8*PM-19 seconds (the setting is according to the motor that users select). When motor outputs no current, the motor temperature drops to the normal level within 12*PM-20 seconds. That is to say, if users operate the motor by the above pattern, it will not exceed the protection level. However, if motor only generates no current in a short time, it will exceed the protection level.

PM-20	Overload Gain (Temperature Falls)		Address:
	Applicable motor type :	ALL	Related Section: -
	Operational Interface :	Panel / Software Communication	
	Default :	100	
	Unit :	%	
	Range :	15~600	
	Data Size :	16bit	
	Format :	DEC	
	Settings :	Please refer to PM-19	

PM-21	Cogging Compensation		Address:
	Applicable motor type :	ALL	Related Section: -
	Operational Interface :	Panel / Software Communication	
	Default :	0x1A00	
	Unit :		
	Range :	0x1100~0xAA11	
	Data Size :	16bit	
	Format :	HEX	

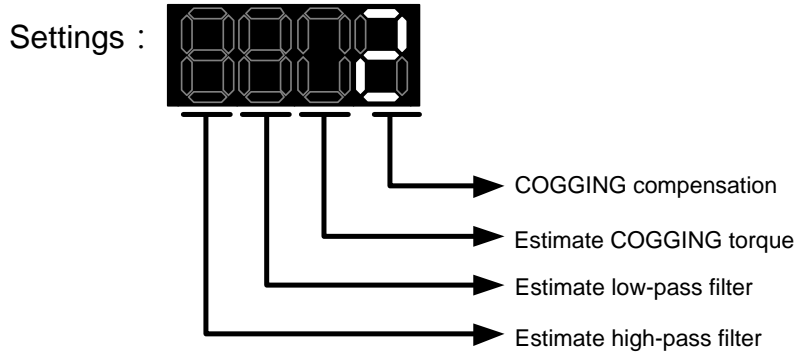

COGGING compensation
 1: Enable function of COGGING compensation
 0: Disable function of COGGING compensation

Estimate COGGING torque
 1: Enable COGGING torque estimation
 0: Disable COGGING torque estimation

Estimate low-pass filter
 1~A: 30~300HZ

Estimate high-pass filter
 1~A: 0.5~5HZ

PM-22	Motor Temperature Sensor		Address:
	Applicable motor type :	ALL	
	Operational Interface :	Panel / Software	Communication
	Default :	0	
	Unit :	N/A	
	Range :	0~3	
	Data Size :	16bit	
	Format :	DEC	

Related Section: -

Settings :
 0: Do not connect to motor temperature sensor
 1: NTC thermal resistor of Delta linear motor
 3: Frequently-closed temperature switch
 Wiring of CN5 temperature sensor:
 Connect the two pin of temperature sensor to 13 pin and 14 pin respectively.

PM-23	Reserved	Address:
--------------	-----------------	-----------------

PM-24	Reserved	Address:
--------------	-----------------	-----------------

PM-25	Reserved	Address:
--------------	----------	-----------------

PM-26	Reserved (FOR BARCODE)	Address:
--------------	------------------------	-----------------

PM-27	Reserved (FOR BARCODE)	Address:
--------------	------------------------	-----------------

PM-28	PM Motor Poles		Address:
Applicable motor type :	SPM, IPM		Related Section: -
Operational Interface :	Panel / Software	Communication	
Default :	10		
Unit :	pole		
Range :	2~ 20		
Data Size :	16bit		
Format :	DEC		
Settings :			

PM-29	PM Motor Rated Current		Address:
Applicable motor type :	SPMI, IPM		Related Section: -
Operational Interface :	Panel / Software	Communication	
Default :	30		
Unit :	0.01A		
Range :	0 ~ the rated current of servo drive		
Data Size :	16bit		
Format :	DEC		
Settings :			

PM-30	The Max. Current of PM Motor		Address:
	Applicable motor type :	SPM, IPM	
	Operational Interface :	Panel / Software	Communication
	Default :	0x0100	
	Unit :	0.01A	
	Range :	0 ~ the rated current of servo drive	
	Data Size :	16bit	
	Format :	DEC	
	Settings :		

PM-31	PM Motor Rated Speed		Address:
	Applicable motor type :	SPM, IPM	
	Operational Interface :	Panel / Software	Communication
	Default :	3000	
	Unit :	rpm	
	Range :	0 ~ 6000	
	Data Size :	16bit	
	Format :	DEC	
	Settings :		

PM-32	The Max. Speed of PM Motor		Address:
Applicable motor type :	SPM, IPM		Related Section: -
Operational Interface :	Panel / Software	Communication	
Default :	5000		
Unit :	rpm		
Range :	0~6000		
Data Size :	16bit		
Format :	DEC		
Settings :			

PM-33	PM Motor Torque (Force) Constant		Address:
Applicable motor type :	SPM, IPM		Related Section: -
Operational Interface :	Panel / Software	Communication	
Default :	0		
Unit :	0.001Nm / A		
Range :	0~13850		
Data Size :	16bit		
Format :	DEC		
Settings :			

PM-34	PM Motor Inertia		Address:
Applicable motor type :	SPM, IPM		Related Section: -
Operational Interface :	Panel / Software	Communication	
Default :	0		
Unit :	10^{-7} kg.m^2		
Range :	0~2147483647		
Data Size :	32bit		
Format :	DEC		

Settings :

PM-35	PM Motor Phase Resistance		Address:
Applicable motor type :	SPM, IPM		Related Section: -
Operational Interface :	Panel / Software	Communication	
Default :	0		
Unit :	0.001ohm		
Range :	0~15999		
Data Size :	16bit		
Format :	DEC		

Settings :

PM-36	PM Motor Phase Inductance		Address:
	Applicable motor type :	SPM, IPM	
	Operational Interface :	Panel / Software	Communication
	Default :	0	
	Unit :	0.01mh	
	Range :	0~3200	
	Data Size :	16bit	
	Format :	DEC	
	Settings :		

PM-37	Reserved	Address:
--------------	-----------------	-----------------

PM-38	PM Motor Back EMF Constant		Address:
	Applicable motor type :	SPM, IPM	
	Operational Interface :	Panel / Software	Communication
	Default :	0	
	Unit :	10 ⁻⁴ Volt/rpm	
	Range :	0~1209	
	Data Size :	16bit	
	Format :	DEC	
	Settings :		

PM-39	Reserved	Address:
--------------	-----------------	-----------------

PM-40	Reserved	Address:
--------------	-----------------	-----------------

PM-41	Reserved	Address:
--------------	-----------------	-----------------

PM-42	Reserved	Address:
--------------	-----------------	-----------------

PM-43	Reserved	Address:
--------------	----------	----------

PM-44	Reserved	Address:
--------------	----------	----------

PM-45	Linear Motor Pole Pitch		Address:
	Applicable motor type :	LM	Related Section: -
	Operational Interface :	Panel / Software Communication	
	Default :	0	
	Unit :	0.1mm/360° (electrical angle)	
	Range :	0~32767	
	Data Size :	16bit	
	Format :	DEC	
	Settings :		

PM-46	Linear Motor Rated Current		Address:
	Applicable motor type :	LM	Related Section: -
	Operational Interface :	Panel / Software Communication	
	Default :	30	
	Unit :	0.01A	
	Range :	0 ~ the rated current of servo drive	
	Data Size :	16bit	
	Format :	DEC	
	Settings :		

PM-47	Max. Current of Linear Motor		Address:
Applicable motor type :	LM		Related Section: -
Operational Interface :	Panel / Software	Communication	
Default :	100		
Unit :	0.01A		
Range :	0 ~ the rated current of servo drive		
Data Size :	16bit		
Format :	DEC		
Settings :			

PM-48	Max. Speed of Linear Motor		Address:
Applicable motor type :	LM		Related Section: -
Operational Interface :	Panel / Software	Communication	
Default :	5000		
Unit :	10^{-3} m/s		
Range :	0~15999		
Data Size :	16bit		
Format :	DEC		
Settings :			

PM-49	Force Constant of Linear Motor		Address:
Applicable motor type :	LM		Related Section: -
Operational Interface :	Panel / Software	Communication	
Default :	0		
Unit :	0.01N / A		
Range :	0~177362		
Data Size :	32bit		
Settings :			

Format :	DEC
----------	-----

Settings :

PM-50	Linear Motor Phase Resistance		Address:
	Applicable motor type :	LM	Related Section: -
	Operational Interface :	Panel / Software Communication	
	Default :	0	
	Unit :	0.001ohm	
	Range :	0~63999	
	Data Size :	16bit	
	Format :	DEC	

Settings :

PM-51	Linear Motor Phase Inductance		Address:
	Applicable motor type :	LM	Related Section: -
	Operational Interface :	Panel / Software Communication	
	Default :	0	
	Unit :	0.01mh	
	Range :	0~65189	
	Data Size :	16bit	
	Format :	DEC	

Settings :

PM-52	Reserved	Address:
--------------	-----------------	-----------------

PM-53	Linear Motor Back EMF Constant		Address:
	Applicable motor type :	LM	
	Operational Interface :	Panel / Software	Communication
	Default :	0	
	Unit :	10 ⁻¹ Volt/(m/s)	
	Range :	0~11824	
	Data Size :	16bit	
	Format :	DEC	
	Settings :		

PM-54	Reserved	Address:
PM-55	Reserved	Address:
PM-56	Reserved	Address:
PM-57	Reserved	Address:
PM-58	Reserved	Address:
PM-59	Reserved	Address:
PM-60	Reserved	Address:
PM-61	Reserved	Address:
PM-62	Reserved	Address:
PM-63	Reserved	Address:

Table 8.1 Function Description of Digital Input (DI)

Setting Value: 0x01			
DI Name	Function Description of Digital Input (DI)	Trigger Method	Control Mode
SON	When this DI is On, servo is activated (Servo On)	Level triggered	ALL

Setting Value: 0x02			
DI Name	Function Description of Digital Input (DI)	Trigger Method	Control Mode
ARST	After the alarm has been cleared, when the DI is ON the drive will show that the alarm has been cleared.	Rising edge triggered	ALL

Setting Value: 0x03			
DI Name	Function Description of Digital Input (DI)	Trigger Method	Control Mode
GAINUP	In speed and position mode, when the DI is ON (P2-27 should be set to 1), the gain switched to the one multiplies the switching rate.	Level triggered	PT, PR, S

Setting Value: 0x04			
DI Name	Function Description of Digital Input (DI)	Trigger Method	Control Mode
CCLR	Clear the pulse counter and the setting of parameter P2-50. 0: clear the position pulse deviation (It is suitable in PT mode). When DI is ON, the accumulative pulse deviation of the drive will be cleared to 0.	Rising edge triggered, Level triggered	PT, PR

Setting Value: 0x05			
DI Name	Function Description of Digital Input (DI)	Trigger Method	Control Mode
ZCLAMP	When the speed is slower than the setting of zero speed (P1-38), if the DI is ON, the motor stops running.	Level triggered	S

The diagram illustrates the ZCLAMP function. It consists of three vertically aligned waveforms sharing a common time axis. The top waveform is 'Speed Command', showing two trapezoidal pulses. The middle waveform is 'ZCLAMP input signal', which is 'OFF' during the first pulse and 'ON' during the second pulse. The bottom waveform is 'Motor Speed', which follows the Speed Command but drops to zero when the ZCLAMP signal is ON. A horizontal dashed line across all three plots is labeled 'Setting value of P1-38 (Zero speed)'. Vertical dashed lines connect the start and end of the speed pulses to the ZCLAMP signal transitions.

Setting Value: 0x06

DI Name	Function Description of Digital Input (DI)	Trigger Method	Control Mode
CMDINV	In PT and speed mode, when the DI is ON, the input command will be in reverse direction.	Level triggered	S, T

Setting Value: 0x07

DI Name	Function Description of Digital Input (DI)	Trigger Method	Control Mode
SPDTMC	The acceleration /deceleration time of internal speed and analog speed is 1msec.	Level triggered	S

Setting Value: 0x08

DI Name	Function Description of Digital Input (DI)	Trigger Method	Control Mode
CTRG	In PR mode, after selecting the PR command (POS0 ~ 5), when the DI is ON, the motor will rotate according to the command issued by the register.	Rising edge triggered	PR

Setting Value: 0x09

DI Name	Function Description of Digital Input (DI)	Trigger Method	Control Mode
TRQLM	In speed and position mode, when the DI is ON, the motor torque (force) will be limited, and the limited torque (force) command will be internal register or analog voltage command.	Level triggered	PT, PR, S

Setting Value: 0x0A

DI Name	Function Description of Digital Input (DI)	Trigger Method	Control Mode
GTRY	Gantry control function	Rising edge triggered	PT

Setting Value: 0x0B

DI Name	Function Description of Digital Input (DI)	Trigger Method	Control Mode
FHS	The switch between full-/ half- closed loop mode.	Level triggered	PT/PR Full-closed loop

Setting Value: 0x0E

DI Name	Function Description of Digital Input (DI)	Trigger Method	Control Mode
FEC	Clear the error between full-closed loop linear scale and motor encoder	Rising edge triggered	PT/PR Full-closed loop

Setting Value: 0x0F			
DI Name	Function Description of Digital Input (DI)	Trigger Method	Control Mode
SPDKVC	Switch between the 1 st set of analog (P1-40) and the 2 nd set (P1-81)	Level triggered	S

Setting Value: 0x10			
DI Name	Function Description of Digital Input (DI)	Trigger Method	Control Mode
SPDLM	In torque mode, when the DI is ON, the motor speed will be limited, the limited speed command will be internal register or analog voltage command.	Level triggered	T

Setting Value: 0x11, 0x12, 0x13, 0x1A, 0x1B, 0x1C											
DI Name	Function Description of Digital Input (DI)									Trigger Method	Control Mode
POS0	PR Command Selection (1~64)									Level triggered	PR
POS1	Position Command	POS5	POS4	POS3	POS2	POS1	POS0	CTRG	Corresponding Parameter		
POS2	Homing	0	0	0	0	0	0	↑	P6-00		
POS3									P6-01		
POS4	Procedure1	0	0	0	0	0	1	↑	P6-02		
POS5									P6-03		
	~										
	Procedure 50	1	1	0	0	1	0	↑	P6-98		
									P6-99		
	Procedure 51	1	1	0	0	1	1	↑	P7-00		
									P7-01		
	~										
	Procedure 63	1	1	1	1	1	1	↑	P7-26		
									P7-27		

Setting Value: 0x1D			
DI Name	Function Description of Digital Input (DI)	Trigger Method	Control Mode
ABSE	When DI.ABSE is ON, it is in ABS mode. DI.ABSQ, DI.ABSC, DI.ABSR, DI.ABSD and DI.ABSC are enabled. When DI.ABSE is ON, the function of DI4, DO2, DO3 will be disabled. Function of DI4 will be ASDQ, DO2 will be ABSR and DO3 will be ABSD.	Level triggered	ALL

Setting Value: 0x1F			
DI Name	Function Description of Digital Input (DI)	Trigger Method	Control Mode
ABSC	When DI.ABSC is ON, multi-turn data stored in absolute encoder will be cleared. When DI.ABSE is ON, this function is enabled.	Rising edge triggered	ALL

Setting Value: When DI.ABSE is ON, DI4 inputs ABSQ signal, function set by P2-13 is disabled.

DI Name	Function Description of Digital Input (DI)	Trigger Method	Control Mode
ABSQ is always inputted by DI4	During I/O transmission, Handshaking signal will be sent to the servo drive by the controller. When DI.ABSQ is OFF, it means the controller issues Request ; DI.ABSQ is ON means the controller has already received ABSQ signal. When DI.ABSE is ON, this DI is enabled. Please refer to diagram 13.4 for detailed description.	Rising and Falling edge triggered	ALL

Setting Value: 0x14, 0x15

DI Name	Function Description of Digital Input (DI)						Trigger Method	Control Mode
SPD0 SPD1	Internal Speed Command Selection (1~4)						Level triggered	S
Speed Command Number	DI signal of CN1		Command Source		Content	Range		
	SPD1	SPD0						
S1	0	0	Mode	S External analog command	Voltage deviation between V-REF and GND	+/-10 V		
				Sz N/A	Speed command is 0	0		
S2	0	1	Register parameter		P1-09	+/-5000 r/min		
S3	1	0			P1-10	+/-5000 r/min		
S4	1	1			P1-11	+/-5000 r/min		

Setting Value: 0x16, 0x17

DI Name	Function Description of Digital Input (DI)						Trigger Method	Control Mode
TCM0 TCM1	Internal Torque (Force) Command Selection (1~4)						Level triggered	T
Torque (force) command number	DI signal of CN1		Command Source		Content	Range		
	TCM1	TCM0						
T1	0	0	Mode	T Analog command	Voltage deviation between V-REF and GND	+/- 10 V		
				Tz N/A	Torque (force) command is 0	0		
T2	0	1	Register parameter		P1-12	+/- 300 %		
T3	1	0			P1-13	+/- 300 %		
T4	1	1			P1-14	+/- 300 %		

Setting Value: 0x18			
DI Name	Function Description of Digital Input (DI)	Trigger Method	Control Mode
S-P	In position and speed mode, if the DI is OFF, it is in speed mode. And it is in position mode when the DI is ON. (P selects PT or PR via DI.PT-PR (0x2B).)	Level triggered	Dual Mode

Setting Value: 0x19			
DI Name	Function Description of Digital Input (DI)	Trigger Method	Control Mode
S-T	In speed and torque (force) mode, if the DI is OFF, it is in speed mode. And it is in torque (force) mode when the DI is ON.	Level triggered	Dual Mode

Setting Value: 0x20			
DI Name	Function Description of Digital Input (DI)	Trigger Method	Control Mode
T-P	In position and torque (force) mode, if the DI is OFF, it is in torque (force) mode; if the DI is ON, then it is in position mode.	Level triggered	Dual Mode

Setting Value: 0x21			
DI Name	Function Description of Digital Input (DI)	Trigger Method	Control Mode
EMGS	When this DI is ON, the motor stops urgently.	Level triggered	ALL

Setting Value: 0x22			
DI Name	Function Description of Digital Input (DI)	Trigger Method	Control Mode
NL (CWL)	Reverse inhibit limit (contact b)	Level triggered	ALL

Setting Value: 0x23			
DI Name	Function Description of Digital Input (DI)	Trigger Method	Control Mode
PL (CCWL)	Forward inhibit limit (contact b)	Level triggered	ALL

Setting Value: 0x24			
DI Name	Function Description of Digital Input (DI)	Trigger Method	Control Mode
ORGP	In PR mode, during the process of homing if the DI is ON ← → OFF, the servo will regard this position as the homing origin. (Please refer to the setting of parameter P5-04)	Rising / Falling edge triggered	PR

Setting Value: 0x27

DI Name	Function Description of Digital Input (DI)	Trigger Method	Control Mode
SHOM	In PR mode, when searching the origin is needed, it will activate the function of searching the origin when the DI is ON. (Please refer to the setting of parameter P5-04)	Rising edge triggered	PR

Setting Value: 0x28

DI Name	Function Description of Digital Input (DI)	Trigger Method	Control Mode
	Reserved		

Setting Value: 0x2B

DI Name	Function Description of Digital Input (DI)	Trigger Method	Control Mode
PT-PR	When selecting PT-PR dual mode or PT-PR-S multiple mode, source can be selected via this DI. If this DI is OFF, it is in PT mode; If the DI is ON, it is in PR mode.	Level triggered	Dual Mode

Setting Value: 0x36

DI Name	Function Description of Digital Input (DI)	Trigger Method	Control Mode
CAM	E-Cam engaging control (Please refer to the setting of P5-88 U, Z value)	Rising / Falling edge triggered	PR

Setting Value: 0x37

DI Name	Function Description of Digital Input (DI)	Trigger Method	Control Mode
JOGU	When this DI is ON, the motor will JOG in forward direction.	Level triggered	ALL

Setting Value: 0x38

DI Name	Function Description of Digital Input (DI)	Trigger Method	Control Mode
JOGD	When this DI is on, the motor will JOG in reverse direction.	Level triggered	ALL

Setting Value: 0x39

DI Name	Function Description of Digital Input (DI)	Trigger Method	Control Mode
EV1	Event trigger command #1 (Refer to the setting of P5-98, P5-99)	Rising /Falling edge triggered	PR

Setting Value: 0x3A			
DI Name	Function Description of Digital Input (DI)	Trigger Method	Control Mode
EV2	Event trigger command #2 (Refer to the setting of P5-98, P5-99)	Rising /Falling edge triggered	PR

Setting Value: 0x3B			
DI Name	Function Description of Digital Input (DI)	Trigger Method	Control Mode
EV3	Event trigger command #3 (It is provided after firmware version V1.008 sub04.)	Rising /Falling edge triggered	PR

Setting Value: 0x3C			
DI Name	Function Description of Digital Input (DI)	Trigger Method	Control Mode
EV4	Event trigger command #4 (It is provided after firmware version V1.008 sub04)	Rising /Falling edge triggered	PR

Setting Value: 0x43, 0x44			
DI Name	Function Description of Digital Input (DI)	Trigger Method	Control Mode
GNUM0 GNUM1	Gear Ratio Selection 0 (Numerator) Gear Ratio Selection 1 (Numerator) <div style="text-align: center; margin-top: 10px;"> </div>	Level triggered	PT

Setting Value: 0x45			
DI Name	Function Description of Digital Input (DI)	Trigger Method	Control Mode
INHP	In position mode, when this DI is ON, the external pulse input command is not working. (Note: The function has to be set to DI8 so as to ensure the instantaneity of pulse prohibition)	Level triggered	PT

Setting Value: 0x46			
DI Name	Function Description of Digital Input (DI)	Trigger Method	Control Mode
STOP	Motor stops	Rising edge triggered	PR

Note : (1) 11~17 Single control mode; 18~20 Dual control mode. (2) When P2-10 ~ P2-17 is set to 0, DI has no function.

Table 8.2 Function Description of Digital Output (DO)

Setting Value: 0x01			
DO Name	Function Description of Digital Output (DO)	Trigger Method	Control Mode
SRDY	When the controlled and main circuit power is applied to the drive, this DO is ON if no alarm occurs.	Level triggered	ALL

Setting Value: 0x02			
DO Name	Function Description of Digital Output (DO)	Trigger Method	Control Mode
SON	When the servo is ON, this DO is ON if no alarm occurs.	Level triggered	ALL

Setting Value: 0x03			
DO Name	Function Description of Digital Output (DO)	Trigger Method	Control Mode
ZSPD	When the motor speed is slower than the setting speed of zero speed (P1-38), this DO is ON.	Level triggered	ALL

Setting Value: 0x04			
DO Name	Function Description of Digital Output (DO)	Trigger Method	Control Mode
TSPD	When the motor speed is faster than the target speed (P1-39), this DO is ON.	Level triggered	ALL

Setting Value: 0x05			
DO Name	Function Description of Digital Output (DO)	Trigger Method	Control Mode
TPOS	In position mode, when the deviation pulse number is smaller than the position range (the setting value of P1-54), this DO is ON.	Level triggered	PT, PR

Setting Value: 0x06			
DO Name	Function Description of Digital Output (DO)	Trigger Method	Control Mode
TQL	When it is in torque (force) limit, this DO is ON.	Level triggered	ALL , except T, Tz

Setting Value: 0x07			
DO Name	Function Description of Digital Output (DO)	Trigger Method	Control Mode
ALRM	When the alarm occurs, this DO is ON. (Except forward / reverse limit, communication error, undervoltage, abnormal fan)	Level triggered	ALL

Setting Value: 0x08			
DO Name	Function Description of Digital Output (DO)	Trigger Method	Control Mode
BRKR	<p>When the signal of brake control is output, adjust the setting of parameter P1-42 and</p> <p>P1-43.</p>	Level triggered	ALL

Setting Value: 0x09			
DO Name	Function Description of Digital Output (DO)	Trigger Method	Control Mode
HOME	<p>When homing is completed, it means the position coordinates system is available and this DO is ON.</p> <p>When applying to the power, this DO is OFF. When homing is completed, this DO is ON. During the operation, this DO is ON until the counter overflows (including command or feedback) and the DO becomes OFF.</p> <p>When PR triggers homing command, this DO becomes OFF. After homing, this DO becomes ON.</p>	Level triggered	PR

Setting Value: 0x0D		
DO Name	Function Description of Digital Output (DO)	Control Mode
ABSW	Warning of absolute encoder.	ALL

Setting Value: 0x0E		
DO Name	Function Description of Digital Output (DO)	Control Mode
IDXD	Indexing coordinates is valid.	PR

Setting Value: 0x10			
DO Name	Function Description of Digital Output (DO)	Trigger Method	Control Mode
OLW	<p>When reaching the overload setting, this DO is ON.</p> <p>t_{OL} = Overload allowable time of the servo x Setting value of P1-56, when the overload accumulative time exceeds t_{OL}, it will output pre-overload warning (OLW). However, if the overload accumulative time exceeds the overload allowable time of the servo, it will output pre-overload error (ALRM).</p> <p>For example: The setting value of pre-overload warning is 60% (P1-56=60).</p>	Level triggered	ALL

	<p>When the output average load of the servo drive is 200%, if the output time exceeds 8 seconds, the servo drive will show the overload alarm (AL.006).</p> <p>$t_{OL} =$ The output average load of the servo exceeds 200% for 8 seconds x parameter setting value = 8sec x 60% = 4.8sec</p> <p>Result: When the output average load of the servo drive exceeds 200% for 4.8 seconds, this DO is ON. If it exceeds for 8 seconds, then, DO.ALARM is ON.</p>		
--	--	--	--

Setting Value: 0x11

DO Name	Function Description of Digital Output (DO)	Trigger Method	Control Mode
WARN	Warning output (Forward / reverse limit, communication error, undervoltage, abnormal fan)	Level triggered	ALL

Setting Value: 0x12

DO Name	Function Description of Digital Output (DO)	Trigger Method	Control Mode
OVF	Position Command Overflows	Level triggered	PR

Setting Value: 0x13

DO Name	Function Description of Digital Output (DO)	Trigger Method	Control Mode
SNL (SCWL)	Software limit (Reverse limit)	Level triggered	ALL

Setting Value: 0x14

DO Name	Function Description of Digital Output (DO)	Trigger Method	Control Mode
SPL (SCCWL)	Software limit (Forward limit)	Level triggered	ALL

Setting Value: 0x15

DO Name	Function Description of Digital Output (DO)	Trigger Method	Control Mode
Cmd_OK	<p>Complete PR command and enter into PR mode, this DO is ON.</p> <p>When PR command is executing, this DO is OFF.</p> <p>After completing the command, this DO is ON.</p> <p>When the DO is ON, it means the command is completed, but not finishing motor positioning. Please refer to DO.TPOS.</p>	Level triggered	PR

Setting Value: 0x16

DO Name	Function Description of Digital Output (DO)	Trigger Method	Control Mode
CAP_OK	CAP procedure completed	Level triggered	ALL

Setting Value: 0x17

DO Name	Function Description of Digital Output (DO)	Trigger Method	Control Mode
MC_OK	When DO.Cmd_OK and TPOS are both ON, this DO is ON. Refer to P1-48.	Level triggered	PR

Setting Value: 0x18

DO Name	Function Description of Digital Output (DO)	Trigger Method	Control Mode
CAM_AREA	Master of E-Cam locates in setting area.	Level triggered	PR

Setting Value: 0x19

DO Name	Function Description of Digital Output (DO)	Trigger Method	Control Mode
SP_OK	Speed completed output: In speed mode, when the deviation between the speed feedback and the command is smaller than the setting value of P1-47, then this DO is ON.	Level triggered	S / Sz

Setting Value: When DI.ABSE is ON, DO2 outputs ABSR signal, function set by P2-19 is disabled.

DO Name	Function Description of Digital Output (DO)	Trigger Method	Control Mode
ABSR is always outputted by DO2	DO.ABSR is OFF means the Request sent by ABSQ has been received. DO.ABSR is ON means the data that is outputted by ABSD is valid. When DI.ABSE is ON, this DO is enabled. Please refer to diagram 13.4 for detailed description.	Level triggered	ALL

Setting Value: When DI.ABSE is ON, DO3 outputs ABSD signal, function set by P2-20 is disabled.

DO Name	Function Description of Digital Output (DO)	Trigger Method	Control Mode
ABSD is always outputted by DO3	Position data of ABS is outputted. The data is valid when ABSR is ON. When DI.ABSE is ON, this DO is enabled. Please refer to diagram 13.4 for detailed description.	Level triggered	ALL

Setting Value: 0x30

DO Name	Function Description of Digital Output (DO)	Trigger Method	Control Mode
SDO_0	Ouput the status of bit 00 of P4-06	Level triggered	ALL

Setting Value: 0x31

DO Name	Function Description of Digital Output (DO)	Trigger Method	Control Mode
SDO_1	Ouput the status of bit 01 of P4-06	Level triggered	ALL

Setting Value: 0x32

DO Name	Function Description of Digital Output (DO)	Trigger Method	Control Mode
SDO_2	Ouput the status of bit 02 of P4-06	Level triggered	ALL

Setting Value: 0x33

DO Name	Function Description of Digital Output (DO)	Trigger Method	Control Mode
SDO_3	Ouput the status of bit 03 of P4-06	Level triggered	ALL

Setting Value: 0x34

DO Name	Function Description of Digital Output (DO)	Trigger Method	Control Mode
SDO_4	Ouput the status of bit 04 of P4-06	Level triggered	ALL

Setting Value: 0x35

DO Name	Function Description of Digital Output (DO)	Trigger Method	Control Mode
SDO_5	Ouput the status of bit 05 of P4-06	Level triggered	ALL

Setting Value: 0x36

DO Name	Function Description of Digital Output (DO)	Trigger Method	Control Mode
SDO_6	Ouput the status of bit 06 of P4-06	Level triggered	ALL

Setting Value: 0x37

DO Name	Function Description of Digital Output (DO)	Trigger Method	Control Mode
SDO_7	Ouput the status of bit 07 of P4-06	Level triggered	ALL

Setting Value: 0x38

DO Name	Function Description of Digital Output (DO)	Trigger Method	Control Mode
SDO_8	Ouput the status of bit 08 of P4-06	Level triggered	ALL

Setting Value: 0x39

DO Name	Function Description of Digital Output (DO)	Trigger Method	Control Mode
SDO_9	Ouput the status of bit 09 of P4-06	Level triggered	ALL

Setting Value: 0x3A

DO Name	Function Description of Digital Output (DO)	Trigger Method	Control Mode
SDO_A	Ouput the status of bit 10 of P4-06	Level triggered	ALL

Setting Value: 0x3B

DO Name	Function Description of Digital Output (DO)	Trigger Method	Control Mode
SDO_B	Ouput the status of bit 11 of P4-06	Level triggered	ALL

Setting Value: 0x3C

DO Name	Function Description of Digital Output (DO)	Trigger Method	Control Mode
SDO_C	Ouput the status of bit 12 of P4-06	Level triggered	ALL

Setting Value: 0x3D

DO Name	Function Description of Digital Output (DO)	Trigger Method	Control Mode
SDO_D	Ouput the status of bit 13 of P4-06	Level triggered	ALL

Setting Value: 0x3E

DO Name	Function Description of Digital Output (DO)	Trigger Method	Control Mode
SDO_E	Ouput the status of bit 14 of P4-06	Level triggered	ALL

Setting Value: 0x3F

DO Name	Function Description of Digital Output (DO)	Trigger Method	Control Mode
SDO_F	Ouput the status of bit 15 of P4-06	Level triggered	ALL

Note : 1) When P2-18 ~ P2-22 is set to 0, DO has no function.

Chapter 9 Communication

9.1 RS-485 Communication Hardware Interface

This servo drive supports the serial communication of RS-485. Communication function enables the servo drive to access and change parameters inside the system. Followings are the wiring description.

■ Configuration

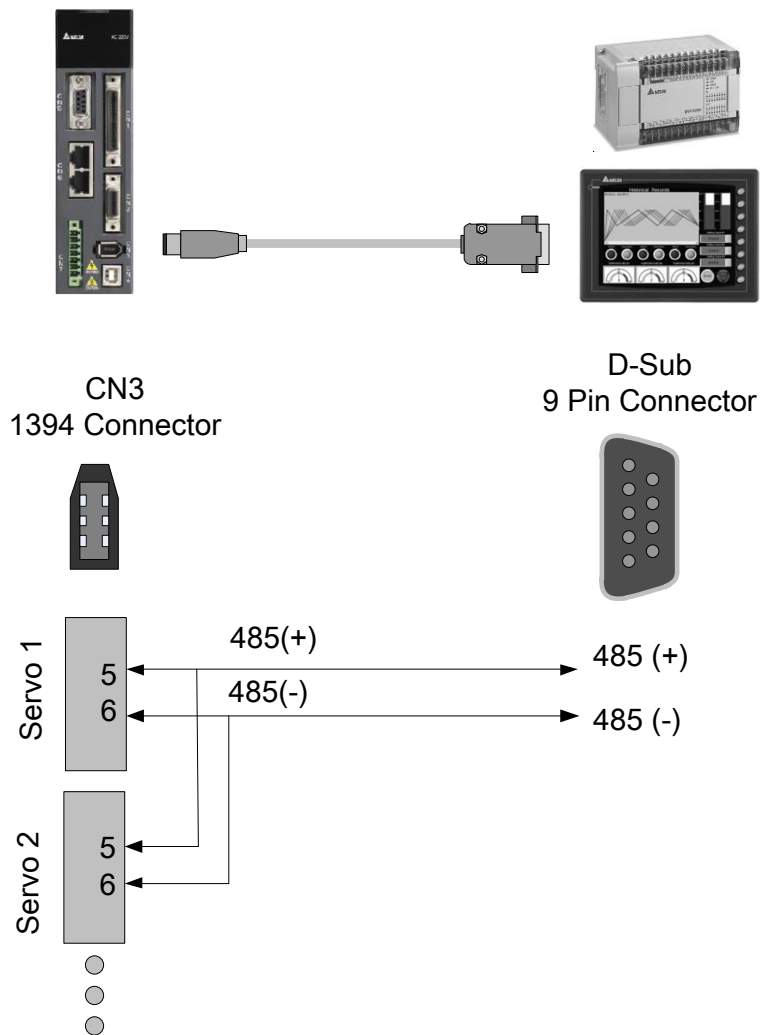

Note:

- 1) 100 meters of communication cable is suitable for less interference environment. If the transmission speed is over 38400bps, the length of communication cable should not longer than 15 meters so as to ensure the accuracy of transmission.
- 2) Numbers shown in the above diagram represent the pin number of each connector.
- 3) Please use the power supply unit whose direct current is over 12 volt.
- 4) Using RS-485 can connect up to 32 servo drives at the same time. REPEATER can be used to connect more servo drives. 127 is the maximum.
- 5) Please refer to Chapter 3.6 for CN3 Pin Definition.

9.2 RS-485 Communication Parameters Setting

The following four parameters, P3-00 (Address Setting), P3-01 (Transmission Speed), P3-02 (Communication Protocol) and P3-05 (Communication Mechanism), are essential and must be set for the communication of the servo drive. The rest, such as P3-03 (Communication Error Disposal), P3-04 (Communication Timeout), P3-06 (Control Switch of Digital Input), P3-07 (Communication Response Delay Time) and P3-08 (Monitor Mode) is optional. Please refer to Chapter 8 of this user manual.

Communication Parameter									
Parameter	Abbr.	Function	Default	Unit	Control Mode				Related Section
					PT	PR	S	T	
P3-00●	ADR	Address Setting	0x7F	N/A	O	O	O	O	7.3
P3-01	BRT	Transmission Speed	0x0203	bps	O	O	O	O	7.3
P3-02	PTL	Communication Protocol	6	N/A	O	O	O	O	7.3
P3-05	CMM	Communication Mechanism	0	N/A	O	O	O	O	7.3

- (★) Read-only register, can only read the status. For example: parameter P0-00, P0-10 and P4-00, etc.
- (▲) Setting is unable when Servo On, e.g. parameter P1-00, P1-46 and P2-33, etc.
- (●) Not effective until re-power on or off the servo drive, e.g. parameter P1-01 and P3-00.
- (■) Parameters of no data retained setting, e.g. parameter P2-30 and P3-06.

9.3 MODBUS Communication Protocol

There are two modes of MODBUS networks communication, ASCII (American Standard Code for information interchange) mode and RTU (Remote Terminal Unit) mode. Users could set the needed communication protocol via parameter P3-02. Apart from these two communication modes, this servo drive also supports function of 03H to access more than one data, 06H to write one character and 10H to write multiple characters. Please refer to the following descriptions.

■ Code Description

ASCII Mode:

The so-called ASCII mode is using American Standard Code for Information Interchange (ASCII) to transmit the data. Between two stations (Master and Slave) to transmit data 64H, the master will send '6' which represented by 36H of ASCII code and '4' represented by 34H of ASCII code.

ASCII code of digit 0 to 9 and characters A to F is as follows:

Character	'0'	'1'	'2'	'3'	'4'	'5'	'6'	'7'
ASCII code	30H	31H	32H	33H	34H	35H	36H	37H
Character	'8'	'9'	'A'	'B'	'C'	'D'	'E'	'F'
ASCII code	38H	39H	41H	42H	43H	44H	45H	46H

RTU Mode:

Every 8-bit of data is constituted by two 4-bits hexadecimal characters. If data 64H is transmitted between two stations, it will be transmitted directly, which is more efficient than ASCII mode.

■ Character Structure

Characters will be encoded into the following framing and transmitted in serial. The checking method of different bit is as the following.

10 bits character frame (for 7-bit character)

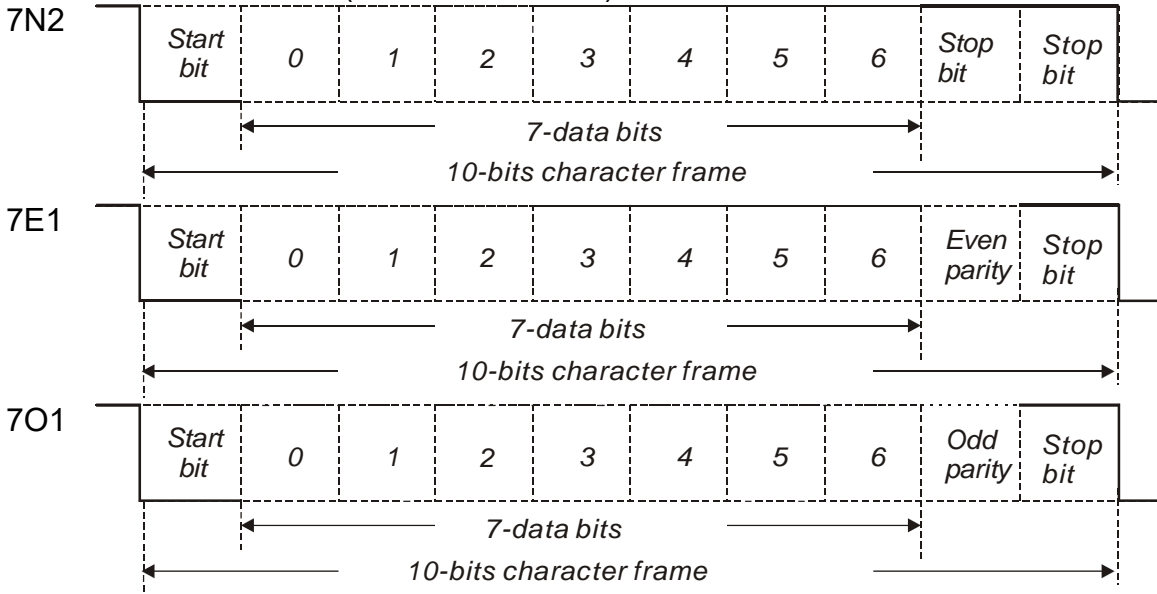

11 bits character frame (for 8-bit character)

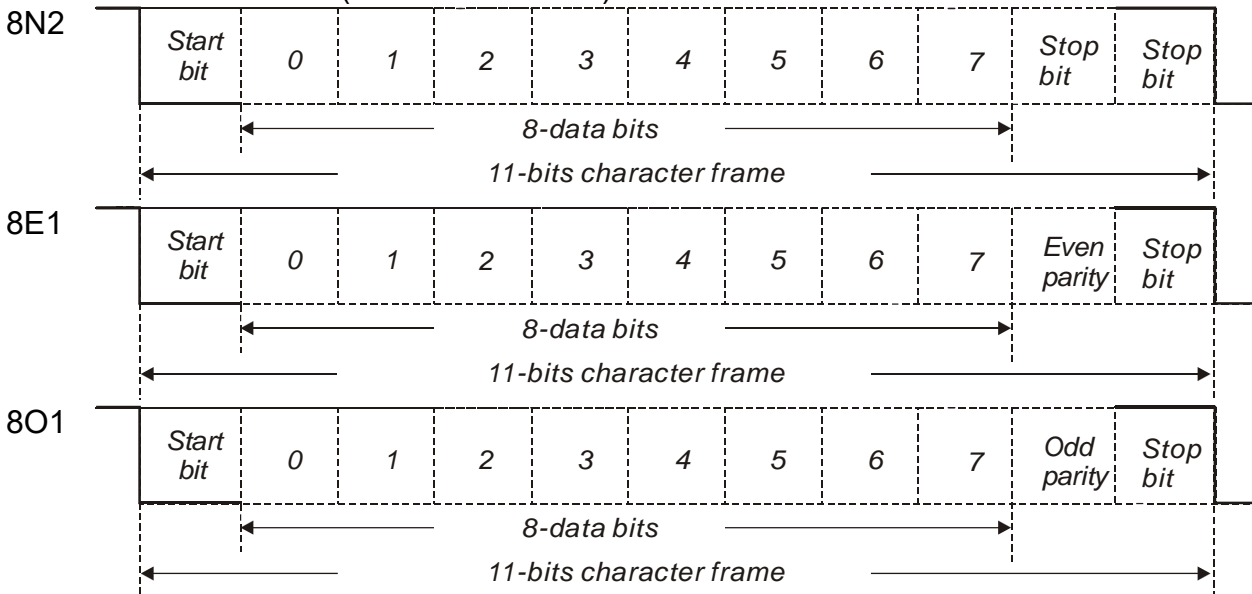

■ Communication Data Structure

The Data Frame in two different communication modes:

ASCII mode:

Start	Start character ' : ' (3AH)
Slave Address	Communication address: 1-byte includes 2 ASCII codes
Function	Function code: 1-byte includes 2 ASCII codes
Data (n-1)	Data content: n-word = 2n-byte includes 4n of ASCII code, n<=10
.....	
Data (0)	
LRC	Error checking: 1-byte includes 2 ASCII codes
End 1	End code 1 : (0DH)(CR)
End 0	End code 0 : (0AH)(LF)

The start character of communication in ASCII mode is colon ' : '(ASCII is 3AH) · ADR is the ASCII code of two characters. The end code is CR (Carriage Return) and LF (Line Feed). And the communication address, function code, data content, error checking LRC (Longitudinal Redundancy Check), etc are between the start character and end code.

RTU mode:

Start	A silent interval which is longer than 10ms
Slave Address	Communication address : 1-byte
Function	Function code : 1-byte
Data (n-1)	Data content : n-word =2n-byte · n<=10
.....	
Data (0)	
CRC	Error checking : 1-byte
End 1	A silent interval which is longer than 10ms

The start of communication in RTU (Remote Terminal Unit) mode is a silent interval. The end of it is another silent interval. The communication address, function code, data content, error checking CRC (Cyclical Redundancy Check), etc are between the start and the end.

Example 1: function code 03H, access multiple words:

The Master issues the command to the 1st Slave and reads the continuous 2 words starting from the start address 0200H. In response message from the Slave, the content of starting address 0200H is 00B1H and the content of the 2nd data address 0201H is 1F40H. The maximum allowable data in one single access is 10. The calculation of LRC and CRC will be described in next chapter.

ASCII mode

Command message from the Master:

Start	‘:’
Slave Address	‘0’
	‘1’
Function	‘0’
	‘3’
Starting data address	‘0’
	‘2’
	‘0’
	‘0’
Number of data (In Word)	‘0’
	‘0’
	‘0’
	‘2’
LRC Check	‘F’
	‘8’
End 1	(0DH)(CR)
End 0	(0AH)(LF)

Response message from the Slave:

Start	‘:’
Slave Address	‘0’
	‘1’
Function	‘0’
	‘3’
Number of data (In Byte)	‘0’
	‘4’
The content of starting address 0200H	‘0’
	‘0’
	‘B’
The content of the 2 nd data address 0201H	‘1’
	‘F’
	‘4’
LRC Check	‘0’
	‘E’
LRC Check	‘8’
	‘8’
End 1	(0DH)(CR)
End 0	(0AH)(LF)

RTU mode:

Command message (Master):

Slave Address	01H
Function	03H
Starting data address	02H (High word)
	00H (Low word)
Number of data (In Word)	00H
	02H
CRC Check Low	C5H (Low word)
CRC Check High	B3H (High word)

Response message (Slave):

Slave Address	01H
Function	03H
Number of data (In Byte)	04H
The content of starting address 0200H	00H (High word)
	B1H (Low word)
The content of the 2 nd data address 0201H	1FH (High word)
	40H (Low word)
CRC Check Low	A3H (Low word)
CRC Check High	D4H (High word)

Note: Before and after the transmission in RTU mode, 10ms of silent interval is needed.

Example 2: function code 06H, write single word:

The Master issues command to the 1st Slave and writes data 0064H to address 0200H. The Slave sends the response message to the Master after the writing is completed. The calculation of LRC and CRC will be described in next chapter.

ASCII mode:

Command message from the Master:

Start	‘:’
Slave Address	‘0’
	‘1’
Function	‘0’
	‘6’
Starting data address	‘0’
	‘2’
	‘0’
	‘0’
Data content	‘0’
	‘0’
	‘6’
	‘4’
LRC Check	‘9’
	‘3’
End 1	(0DH)(CR)
End 0	(0AH)(LF)

Response message from the Slave:

Start	‘:’
Slave Address	‘0’
	‘1’
Function	‘0’
	‘6’
Starting data address	‘0’
	‘2’
	‘0’
	‘0’
Data content	‘0’
	‘0’
	‘6’
	‘4’
LRC Check	‘9’
	‘3’
End 1	(0DH)(CR)
End 0	(0AH)(LF)

RTU mode:

Command message from the Master:

Address	01H
Slave Function	06H
Starting data address	02H (High word)
	00H (Low word)
Data content	00H (High word)
	64H (Low word)
CRC Check Low	89H (Low word)
CRC Check High	99H (High word)

Response message from the Slave:

Address	01H
Slave Function	06H
Starting data address	02H (High word)
	00H (Low word)
Data content	00H (High word)
	64H (Low word)
CRC Check Low	89H (Low word)
CRC Check High	99H (High word)

Note: Before and after the transmission in RTU mode, 10ms of silent interval is needed.

Example 3: function code 10H, write multiple words:

The Master issues command to the 1st Slave and writes 0BB8H and 0000H to the starting address 0112H. That is to say, 0112H is written into 0BB8H and 0113H is written into 0000H. The maximum allowable data in one single access is 10. The Slave sends the response message to the Master after the writing is completed. The calculation of LRC and CRC will be described in next chapter.

ASCII mode:

Command message from the Master:

Start	':'
Slave Address	'0'
	'1'
Function	'1'
	'0'
Starting data address	'0'
	'1'
	'1'
	'2'
Number of data (In Word)	'0'
	'0'
	'0'
	'2'
Number of data (In Byte)	'0'
	'4'
The 1 st data content	'0'
	'B'
	'8'
The 2 nd data content	'0'
	'0'
	'0'
LRC Check	'1'
	'3'
End 1	(0DH)(CR)
End 0	(0AH)(LF)

Response message from the Slave:

Start	':'
Slave Address	'0'
	'1'
Function	'1'
	'0'
Starting data address	'0'
	'1'
	'1'
	'2'
Number of data	'0'
	'0'
	'0'
	'2'
LRC Check	'D'
	'A'
End 1	(0DH)(CR)
End 0	(0AH)(LF)

RTU mode:

Command message from the Master:

Slave Address	01H
Function	10H
Starting data address	01H (High word)
	12H (Low word)
Number of data (In Word)	00H (High word)
	02H (Low word)
Number of data (In Byte)	04H
The 1 st data content	0BH (High word)
	B8H (Low word)
The 2 nd data content	00H (High word)
	00H (Low word)
CRC Check Low	FCH (Low word)
CRC Check High	EBH (High word)

Response message from the Slave:

Slave Address	01H
Function	10H
Starting data address	01H (High word)
	12H (Low word)
Number of data (In Word)	00H (High word)
	02H (Low word)
CRC Check Low	E0H (Low word)
CRC Check High	31H (High word)

Note: Before and after the transmission in RTU mode, 10ms of silent interval is needed.

■ LRC and CRC transmission error checking

The error checking in ASCII communication mode is LRC (Longitudinal Redundancy Check); CRC (Cyclical Redundancy Check) is for RTU communication mode. The algorithm of both is as the following.

LRC (ASCII mode):

Start	‘:’
Slave Address	‘7’
	‘F’
Function	‘0’
	‘3’
Starting data address	‘0’
	‘5’
	‘C’
	‘4’
Number of data	‘0’
	‘0’
	‘0’
	‘1’
LRC Check	‘B’
	‘4’
End 1	(0DH)(CR)
End 0	(0AH)(LF)

The LRC algorithm is: add all byte, round down the carry and take 2’ s complement. For example, 7FH + 03H + 05H + C4H + 00H + 01H = 14CH, round down carry 1 and take 4CH.

2’s complement of 4CH is B4H.

CRC (RTU mode):

The description of CRC is as the followings:

- Step 1: Load a 16-bits register of FFFFH, which is called **CRC** register.
- Step 2: (The low byte of CRC register) XOR (The first byte of command), and save the result in CRC register.
- Step 3: Right move one bit. Check the least significant bit (LSB) of CRC register. If the bit is 1, then (CRC register) XOR (A001H).
- Step 4: Return to Step 3 until Step 3 has been executed for 8 times. Go to Step 5.
- Step 5: Repeat the procedure from Step 2 to Step 4 until all byte is processing. Get the result of CRC value.

Description: After calculating CRC value, fill in the low word of CRC first in command message, and then fill in the high word of CRC. For example, if the result of CRC algorithm is 3794H, fill in 94H in low word and then 37H in high word.

ARD	01H
CMD	03H
Starting data address	01H (High word)
	01H (Low word)
Number of data (in word)	00H (High word)
	02H (Low word)
CRC Check Low	94H (Low word)
CRC Check High	37H (High word)

Example of CRC program:

Produce CRC in C language. This function needs two parameters:

unsigned char* data;

unsigned char length

This function returns CRC of unsigned integer.

```
unsigned int crc_chk(unsigned char* data, unsigned char length) {
    int j;
    unsigned int reg_crc=0xFFFF;

    while( length-- ) {
        reg_crc^= *data++;
        for (j=0; j<8; j++ ) {
            if( reg_crc & 0x01 ) { /*LSB(bit 0 ) = 1 */
                reg_crc = (reg_crc >> 1)^0xA001;
            } else {
                reg_crc = (reg_crc>>1);
            }
        }
    }
    return reg_crc;
}
```

Example of personal computer procedure:

```
#include<stdio.h>
#include<dos.h>
#include<conio.h>
#include<process.h>
#define PORT 0x03F8/* the address of COM 1 */
#define THR 0x0000
#define RDR 0x0000
#define BRDL 0x0000
#define IER 0x0001
#define BRDH 0x0001
#define LCR 0x0003
#define MCR 0x0004
#define LSR 0x0005
#define MSR 0x0006
unsigned char rdat[60];
/* read 2 data from address 0200H of ASD with address 1 */
unsigned char tdat[60]={':', '0', '1', '0', '3', '0', '2', '0', '0', '0', '0', '2', 'F', '8', '\r', '\n'};
void main() {
    int I;
    outportb(PORT+MCR,0x08); /* interrupt enable */
    outportb(PORT+IER,0x01); /* interrupt as data in */
    outportb(PORT+LCR,( inportb(PORT+LCR) | 0x80 ) );
    /* the BRDL/BRDH can be access as LCR.b7 == 1 */
    outportb(PORT+BRDL,12);
    outportb(PORT+BRDH,0x00);
    outportb(PORT+LCR,0x06); /* set prorocol
    <7,E,1> = 1AH, <7,O,1> = 0AH
    <8,N,2> = 07H <8,E,1> = 1BH
```

```
                <8,0,1> = 0BH                                */
for( l = 0; l<=16; l++ ) {
    while( !(inportb(PORT+LSR) & 0x20) ); /* wait until THR empty */
    outportb(PORT+THR,tdat[l]);          /* send data to THR */
}
l = 0;
while( !kbhit() ) {
    if( inportb(PORT+LSR)&0x01 ) { /* b0==1, read data ready */
        rdat[l++] = inportb(PORT+RDR); /* read data from RDR */
    }
}
}
```

9.4 Write-in and Read-out Communication Parameters

Please refer to Chapter 8, Parameters for all parameter details. And the descriptions of parameters which can be wrote or read through communication are as follows.

Parameters are divided into 8 groups, Group 0: Monitor Parameters, Group 1: Basic Parameters, Group 2: Extension Parameters, Group 3: Communication Parameters, Group 4: Diagnosis Parameters, Group 5: Motion Setting, Group 6 and Group 7: PR Definition.

Write parameters via communication:

Parameters which can be written through communication include:

Group 0, except (P0-00~P0-01), (P0-08~P0-13) and (P0-46) Group 1 (P1-00~P1-76)

Group 2 (P2-00~P2-67)

Group 3 (P3-00~P3-11)

Group 4, except (P4-00~P4-04) and (P4-08~P4-09)

Group 5 (P5-00~P5-99), except P5-10, P5-16 and P5-76

Group 6 (P6-00~P6-99)

Group 7 (P7-00~P7-27)

Please note that:

(P3-01) When change to a new communication speed, the next data will be written in a new transmission speed after setting the new value.

(P3-02) When change to the new communication protocol, the next data will be written with the new communication protocol after setting the new value.

(P4-05) JOG controls parameters of the servo. Please refer to Chapter 8, Parameters for the description.

(P4-06) Force to control output contact. This parameter is for DO (Digital Output) testing. Users can write 1, 2, 4, 8 and 16 to test DO1, DO2, DO3, DO4 and DO5 respectively. Please write 0 after the test so as to inform the servo drive that the test has been completed.

(P4-10) Adjustment function selection. Write 20 (= 14H in hexadecimal format) in parameter P2-08 first to enable the adjustment so as to change the value of P4-10.

(P4-11 ~ P4-21) This parameter is Offset Adjustment. Do not change the setting unless it is necessary. If it is necessary, please write 22 (= 16H, in hexadecimal format) in parameter P2-08 first to enable the function so as to change the value of (P4-11 ~ P4-21).

Read parameters through communication:

Parameters can be read through communication include:

Group 0 (P0-00~P0-46)

Group 4 (P4-00~P4-23)

Group 1 (P1-00~P1-76)

Group 5 (P5-00~P5-99)

Group 2 (P2-00~P2-67)

Group 6 (P6-00~P6-99)

Group 3 (P3-00~P3-11)

Group 7 (P7-00~P7-27)

Chapter 10 Troubleshooting

10.1 Alarm of Servo Drive

Display	Alarm Name	Alarm Description	Corresponding DO	Servo Status
AL001	Over current	The current of the main circuit is 1.5 times more than the instantaneous current of the motor.	ALM	Servo Off
AL002	Over voltage	The voltage of the main circuit is higher than the standard voltage.	ALM	Servo Off
AL003	Under voltage	The voltage of the main circuit is lower than the standard voltage.	WARN	Servo Off
AL004	Motor Combination Error	The drive corresponds to the wrong motor.	ALM	Servo Off
AL005	Regeneration Error	Regeneration control is in error.	ALM	Servo Off
AL006	Overload	The motor and the drive is overload.	ALM	Servo Off
AL007	Over speed	The control speed of the motor exceeds the normal speed.	ALM	Servo Off
AL008	Abnormal Pulse Command	The input frequency of the pulse command is over the allowable value of the hardware interface.	ALM	Servo Off
AL009	Excessive Deviation of Position Command	The deviation of position command exceeds the allowable setting value.	ALM	Servo Off
AL011	Encoder Error	The encoder produces abnormal pulse.	ALM	Servo Off
AL012	Adjustment Error	When executing electrical adjustment, the adjusted value exceeds the allowable value.	ALM	Servo Off
AL013	Emergency Stop	Press the emergency stop button.	WARN	Servo Off
AL014	Reverse Limit Error	Activate the reverse limit switch.	WARN	Servo On
AL015	Forward Limit Error	Activate the forward limit switch.	WARN	Servo On
AL016	IGBT Overheat	The temperature of IGBT is over high	ALM	Servo Off

Display	Alarm Name	Alarm Description	Corresponding DO	Servo Status
AL017	Abnormal EEPROM	It is in error when DSP accesses EEPROM.	ALM	Servo Off
AL018	Abnormal signal output	The encoder output exceeds the rated output frequency.	ALM	Servo Off
AL019	Serial Communication Error	RS-485 communication is in error	ALM	Servo Off
AL020	Serial Communication Time Out	RS-485 communication time out	WARN	Servo On
AL021	Reserved	Reserved		
AL022	Main Circuit Power Lack Phase	Only one single phase is inputted in the main circuit power.	WARN	Servo Off
AL023	Early Warning for Overload	Early Warning for Overload	WARN	Servo On
AL024	Encoder initial magnetic field error	The magnetic field of the encoder U, V, W signal is in error.	ALM	Servo Off
AL025	The Internal of the Encoder is in Error	The internal memory of the encoder and the internal counter are in error.	ALM	Servo Off
AL026	Unreliable internal data of the encoder	The error of the internal data has been detected for three times continuously.	ALM	Servo Off
AL030	Motor Crash Error	The motor crashes the equipment, reaches the torque of P1-57 and exceeds the time set by P1-58.	ALM	Servo Off
AL031	Incorrect wiring of the motor power line U, V, W, GND	Incorrect wiring of the motor power line U, V, W, GND	ALM	Servo Off
AL033	Connection of 26 pin on converter box is breakdown	Connection of 26 pin on converter box (encoder) is breakdown	ALM	Servo Off
AL035	Motor temperature error	Motor' s temperature is too high	ALM	Servo Off

Display	Alarm Name	Alarm Description	Corresponding DO	Servo Status
AL040	Excessive Deviation of Full Closed-loop Position Control	Excessive Deviation of Full Closed-loop Position Control	ALM	Servo Off
AL041	Communication of CN5 is breakdown	Communication of CN5 (encoder) is breakdown	ALM	Servo Off
AL044	Warning of servo drive function overload	Warning of servo drive function overload	WARN	Servo On
AL050	Auto detection of motor parameters is completed.	When executing PM-01, function of auto detection, this alarm will occur when the detection is completed.	ALM	Servo Off
AL051	Auto detection of motor parameters is in error	During auto detection, when friction is too big, motor is stuck or entering wrong resolution and pole pitch, this alarm will occur.	ALM	Servo Off
AL052	Initial magnetic pole detection error	When PM-03.Y = 0, it will detect the initial magnetic pole automatically. When it cannot find the initial magnetic pole, this alarm will occur.	ALM	Servo Off
AL053	Motor parameter is not confirmed	If PM-02 = 0, this alarm will occur when motor servo On.	ALM	Servo Off
AL054	Exceeding the range of motor parameter	Parameter range of linear motor is different from rotary motor. In PM-00, if it exceeds the range when switching the motor type, this alarm will occur.	ALM	Servo Off
AL055	Motor magnetic fields is abnormal	When enabling the Y item of PM-09, servo will detect the motor's current magnetic field, and compare it with the position of Hall sensor's. When the deviation between both is too excessive, this alarm will occur.	ALM	Servo Off
AL057	Feedback pulse is lost	When P2-81 = 1, it will check if the pulse is lost. If the loss amount is more than the value of P2-82, this alarm will occur.	ALM	Servo Off

Display	Alarm Name	Alarm Description	Corresponding DO	Servo Status
AL058	Excessive deviation of initial magnetic pole detection position when power on	During initial magnetic pole detection, it will check if the position error exceeds the range. If yes, this alarm will occur.	ALM	Servo Off
AL067	Motor temperature warning	Motor' s temperature will be over high	WARN	Servo On
AL099	DSP Firmware Upgrade	EEPROM has not been reset after upgrading the firmware. The fault can be cleared when firstly set P2-08 to 30. Then set P2-08 to 28. And re-power on the drive.	ALM	Servo Off

10.2 Alarm of CANopen Communication

Display	Alarm Name	Alarm Description	Corrective Actions	Corresponding DO	Servo Status
AL111	CANopen SDO receives buffer overflow	SDO Rx Buffer overflow (receives more than two SDOs within 1 millisecond)	NMT: Reset node or 0x6040.Fault Reset	ALM	Servo On
AL112	CANopen PDO receives buffer overflow	PDO Rx Buffer overflow (receives more than two same PDOs of the COBID within 1 millisecond)	Same as above	ALM	Servo On
AL121	Index error occurs when accessing CANopen PDO	The specified Index in the message does not exist.	Same as above	ALM	Servo On
AL122	Sub-Index error occurs when accessing CANopen PDO	The specified Sub-Index in the message does not exist.	Same as above	ALM	Servo On
AL123	Data Size error occurs when accessing CANopen PDO	The data length in the message does not match to the specified object.	Same as above	ALM	Servo On
AL124	Data range error occurs when accessing CANopen PDO	The data value in the message is over the range of the specified object.	Same as above	ALM	Servo On

Display	Alarm Name	Alarm Description	Corrective Action	Corresponding DO	Servo Status
AL 125	CANopen PDO object is read-only and write-protected	The specified object in the message is write-protected.	Same as above	ALM	Servo On
AL 126	CANopen PDO object is not allowed in PDO	The specified object in the message does not support PDO	Same as above	ALM	Servo On
AL 127	CANopen PDO object is write-protected when Servo On	The specified object in the message is write-protected when Servo ON	Same as above	ALM	Servo On
AL 128	Error occurs when reading CANopen PDO object via EEPROM	An error occurs when loading the default value via ROM at start-up. All objects of CAN returns to the default value automatically.	Same as above	ALM	Servo On
AL 129	Error occurs when writing CANopen PDO object via EEPROM	An error occurs when saving the current value into ROM.	Same as above	ALM	Servo On
AL 130	The accessing address of EEPROM is out of range when using CANopen PDO object	The quantity of the data inside ROM is over the planned space. It is probably because the software has been updated. The data inside ROM is stored by the old version. Thus, it cannot be used.	Same as above	ALM	Servo On
AL 131	CRC of EEPROM calculation error occurs when using CANopen PDO object	It indicates that the data stored in ROM has been damaged. All objects of CAN will return to the default setting automatically.	Same as above	ALM	Servo On
AL 132	Enter the incorrect password when using CANopen PDO object	When entering parameters via CAN, the parameters are password-protected. Users have to decode the password first.	Same as above	ALM	Servo On
AL 105	Abnormal CAN Bus hardware	The communication of CAN Bus is breakdown or Error Rx/Tx Counter is over 128.	NMT: Reset node or re-servo on	ALM	Servo On

10.3 Alarm of Motion Control

Display	Alarm Name	Alarm Description	Corrective Actions	Corresponding DO	Servo Status
AL201	An error occurs when loading CANopen data	An error occurs when loading data via EEPROM.	DI:ARST, CANopen 0x1011 Restore default parameter	WARN	Servo On
AL213	Write parameters: exceeds the range	Write parameters via PR procedure: the value is over the range.	DI:Alm Reset or P0-01= 0	WARN	Servo On
AL215	Write parameters: read-only	Write parameters via PR procedure: the parameter is read-only	DI:Alm Reset or P0-01= 0	WARN	Servo On
AL217	Write parameters: parameter locked	Write parameters via PR procedure: it is write-protected when the servo is ON or the input data is unreasonable.	Correct the PR command and parameter	WARN	Servo On
AL235	PR command overflows	Feedback position counter overflows and executes the absolute positioning command.	NMT: Reset node or 0x6040.Fault Reset	WARN	Servo On
AL245	PR positioning is over time	The execution of positioning command exceeds the time limit.	Same as above	WARN	Servo On
AL249	The number of PR command exceeds the range	The range of PR command is between 0 and 63, or it will exceed the limit.	Same as above	WARN	Servo On
AL261	Index error occurs when accessing CANopen object	The specified Index in the message does not exist.	DI.ARST NMT: Reset node or 0x6040.Fault Reset	WARN	Servo On
AL263	Sub-Index error occurs when accessing CANopen object	The specified Sub-Index in the message does not exist.	Same as above	WARN	Servo On
AL265	Data Size error occurs when accessing CANopen object	The data length in the message does not match to the specified object.	Same as above	WARN	Servo On

Display	Alarm Name	Alarm Description	Corrective Actions	Corresponding DO	Servo Status
AL267	Data range error occurs when accessing CAN.	The data value in the message is over the range of the specified object.	Same as above	WARN	Servo On
AL269	CANopen object is read-only and write-protected	The specified object in the message is write-protected	Same as above	WARN	Servo On
AL266	PDO is not allowed in CANopen object	The specified object in the message does not support PDO	Same as above	WARN	Servo On
AL268	CANopen object is write-protected when Servo On	The specified object in the message is write-protected when Servo ON	Same as above	WARN	Servo On
AL26F	Error occurs when reading CANopen object via EEPROM	An error occurs when loading the default value via ROM at start-up. All objects of CANopen returns to the default value automatically.	Same as above	WARN	Servo On
AL271	Error occurs when writing CANopen object via EEPROM	An error occurs when saving the current value into ROM.	Same as above	WARN	Servo On
AL273	The accessing address of EEPROM is out of range when using CANopen object	The quantity in the data inside ROM is over the planned space. It is probably because the software has been updated. The data inside ROM is stored by the old version. Thus, it cannot be used.	Same as above	WARN	Servo On
AL275	CRC of EEPROM calculation error occurs when using CANopen object	It indicates that the data stored in ROM has been damaged. All CANopen objects will return to the default setting automatically.	Same as above	WARN	Servo On

Display	Alarm Name	Alarm Description	Corrective Actions	Corresponding DO	Servo Status
AL277	Enter the incorrect password when using CANopen object	When entering parameters via CAN, the parameters are password-protected. Users have to decode the password first.	Same as above	WARN	Servo On
AL283	Forward Software Limit	The value of position command is bigger than forward software limit (P5-08)	The fault will be cleared automatically when the motor operates backwards.	WARN	Servo On
AL285	Reverse Software Limit	The value of position command is smaller than reverse software limit (P5-09)	The fault will be cleared automatically when the motor operates backwards.	WARN	Servo On
AL289	Feedback position counter overflows	Feedback position counter overflows.	NMT: Reset node or 0x6040.Fault Reset	WARN	Servo On
AL291	Servo OFF error	Servo OFF when the motion path is incomplete.	Same as above	WARN	Servo On
AL301	CANopen fails to synchronize	CANopen IP mode fails to synchronize with the controller.	Same as above	WARN	Servo On
AL302	The synchronized signal of CANopen is sent too fast	The synchronized signal, SYNC of CANopen is sent too fast.	Same as above	WARN	Servo On
AL303	The synchronized signal of CANopen is sent too slow	The synchronized signal, SYNC of CANopen has not been received in time.	Same as above	WARN	Servo On
AL304	CANopen IP command is failed	Command cannot be issued in CANopen IP mode.	Same as above	WARN	Servo On
AL305	SYNC Period is in error	CANopen 301 Obj 0x1006 Data Error !	Same as above	WARN	Servo On

Display	Alarm Name	Alarm Description	Corrective Actions	Corresponding DO	Servo Status
	Position Deviation Alarm	Please refer to the description of parameter P1-48. After DO.MC_OK ON, DO.MC_OK becomes OFF because DO.TPOS turns OFF.	DI:Alm Reset or P0-01= 0	WARN	Servo On

Note: if the alarm occurs and is different from the alarm showed in **Alarm of Servo Drive**, **Alarm of CANopen Communication** and **Alarm of Motion Control**, please contact with distributors or technical personnel.

10.4 Causes and Corrective Actions

Alarm Display

AL001

: Over current

Causes	Checking Method	Corrective Actions
The drive output is short-circuit	Check if the wiring between the motor and the drive is correct and see if the wire is short-circuited.	Eliminate short-circuit and avoid metal conductor being exposed.
The motor wiring is in error.	Check if the wiring steps are correct when connecting the motor to the drive.	Rewiring by following the wiring description from the user manual.
IGBT is abnormal	The temperature of the heat sink is abnormal	Send the drive back to the distributors or contact with Delta
The control parameter setting is in error.	Check if the setting value exceeds the default setting	Setting back to the default setting and then gradually adjust the value.
Unreasonable command	Check if the command doing reasonable acceleration time.	Less steep command used or filter applying to smooth command.

AL002

: Over voltage

Causes	Checking Method	Corrective Actions
The input voltage of the main circuit is higher than the rated allowable voltage.	Use the voltmeter to see if the input voltage of the main circuit is within the rated allowable voltage value. (please refer to Chapter 12.1)	Apply to the correct power supply or serial voltage regulator.
Wrong power input (incorrect power system)	Use the voltmeter to see if the power system matches the specification.	Apply to the correct power supply or serial adaptor.
The hardware of the servo drive is damaged.	Use the voltmeter to see if the input voltage of the main circuit is within the rated allowable voltage value but still shows the error.	Send the drive back to the distributors or contact with Delta.

AL003

: Under voltage

Causes	Checking Method	Corrective Actions
The input voltage of the main circuit is lower than the rated allowable voltage.	Check if the input voltage wiring of the main circuit is normal.	Re-confirm the voltage wiring.
No power supply for the main circuit.	Use the voltmeter to see if the voltage of the main circuit is normal.	Check the power switch

Wrong power input (incorrect power system)	Use the voltmeter to see if the power system matches the specification.	Apply to the correct power supply or serial adaptor.
--	---	--

AL004**: Motor Combination Error**

Causes	Checking Method	Corrective Actions
The encoder is damaged.	The encoder is abnormal.	Change the motor
The encoder is loose.	Check the encoder connector.	Install the motor again.
Motor Combination Error	Connect to the right motor.	Change the motor

AL005**: Regeneration Error**

Causes	Checking Method	Corrective Actions
The regenerative resistor is unconnected or too low	Check the connection of regenerative resistor.	Reconnect the regenerative resistor or calculate the value of the regenerative resistor.
Parameter P1-53 is not set to zero when the regenerative resistor is not in use.	Check if parameter P1-53 of regenerative resistor is set to zero.	Set parameter P1-53 of regenerative resistor to zero when it is not applying.
Wrong parameter setting	Check the setting value of parameter P1-52 and P1-53.	Correctly reset the setting.

AL006**: Overload**

Causes	Checking Method	Corrective Actions
Over the rated loading of the drive and continuously excessive using	Set parameter P0-02 to 11 and see if the average torque [%] is over 100% all the time.	Increase the motor capacity or reduce the load.
The setting of the control system parameter is inappropriate.	1. Check if there is any mechanical vibration. 2. Check if the acceleration / deceleration constant is set too fast.	1. Adjust the gain value of the control circuit. 2. Slow down the acceleration / deceleration setting time.
Wrong wiring of the motor and the encoder.	Check the wiring of U, V, W and the encoder.	Correct wiring
The encoder of the motor is defective.	Send the drive back to the distributors or contact with Delta.	

AL007 : Overspeed

Causes	Checking Method	Corrective Actions
Unreasonable command	Use the scope to check if the signal of analog voltage is abnormal.	Less steep command used or filter applying to smooth command.
Inappropriate parameter setting	Check if the setting of parameter P2-34 is too small (the condition of over-speed warning).	Correctly set parameter P2-34 (the condition of over-speed warning).

AL008 : Abnormal Pulse Command

Causes	Checking Method	Corrective Actions
The pulse command frequency is higher than the rated input frequency.	Use the scope to check if the input frequency is over the rated input frequency.	Correctly set the input pulse frequency.

AL009 : Excessive Deviation of Position Command

Causes	Checking Method	Corrective Actions
Parameter P2-35 is set too small	Check the setting value of parameter P2-35 (The warning condition of excessive position deviation)	Increase the setting value of P2-35 (The warning condition of excessive position deviation)
The setting of the gain value is too small.	Check if the setting value is appropriate	Correctly adjust the gain value
The torque limit is too low.	Check the torque limit value	Correctly adjust the torque limit value
Excessive external load	Check the external load	Reduce the external load or evaluate the motor capacity again
Improper setting of E-gear ratio	Make sure if the proportion of P1-44 and P1-45 is appropriate.	Correctly setup E-gear ratio

AL011 : Encoder Error

Causes	Checking Method	Corrective Actions
Wrong wiring of the encoder	Check if the wiring follows the suggested wiring of the user manual.	Correct wiring
The encoder is loose	Check the drive connector of CN2 and encoder	Install the encoder again

Bad connection of the encoder	Check if the connection between CN2 of the drive and the encoder of the servo motor is loose	Reconnect the wiring
The encoder is damaged	Check if the motor is damaged	Change the motor

AL012 : Adjustment Error

Causes	Checking Method	Corrective Actions
The analog input contact is incorrectly set back to zero	Measure if the voltage of the analog input contact is the same as the ground voltage	Correctly ground the analog input contact
The detection device is damaged	Reset the power supply	If the error still occurs after reset, send the drive back to the distributors or contact with Delta.

AL013 : Emergency Stop

Causes	Checking Method	Corrective Actions
Press the emergency stop button	Check if the emergency stop button is enabled.	Activate emergency stop

AL014 : Reverse Limit Error

Causes	Checking Method	Corrective Actions
Reverse limit switch is activated.	Check if the limit switch is enabled.	Enable the reverse limit switch
The servo system is unstable.	Check the control parameter and inertia ratio	Re-adjust the parameter or evaluate the motor capacity.

AL015 : Forward Limit Error

Causes	Checking Method	Corrective Actions
Forward limit switch is activated.	Check if the limit switch is enabled.	Enable the forward limit switch
The servo system is unstable.	Check the control parameter and inertia ratio	Re-adjust the parameter or evaluate the motor capacity.

AL016 : IGBT Overheat

Causes	Checking Method	Corrective Actions
Over the rated loading of the drive and continuously excessive using	Check if it is overloading or the motor current is too high.	Increase the motor capacity or reduce the load.
The drive output is short-circuit	Check the drive output wiring	Correct wiring

AL017 : Abnormal EEPROM

Causes	Checking Method	Corrective Actions
It is in error when DSP accesses EEPROM.	Press the SHIFT Key on the panel and it shows EXGAB. X = 1, 2, 3 G = group code of the parameter AB = hexadecimal of the parameter If it shows E320A, it means it is parameter P2-10; If it shows E3610, it means it is parameter P6-16. Please check the parameter.	The fault occurs when applying to the power. It means one of the parameters is over the reasonable range. Please re-power on after adjusting. The fault occurs in normal operation. It means it is in error when writing the parameter. The alarm can be cleared by DI.ARST.
Abnormal hidden parameter	Press the SHIFT Key on the panel and it shows E100X	The fault occurs in parameter reset. The setting of the drive is wrong. Please set the correct type of the drive.
Data in ROM is damaged.	Press the SHIFT Key on the panel and it shows E0001	The fault occurs when it is servo-on. Usually it is because the data in ROM is damaged or there is no data in ROM. Please send the drive back to the distributors or contact with Delta.

AL018 : Abnormal Signal Output

Causes	Checking Method	Corrective Actions
The encoder is in error and cause the abnormal signal output	Check the fault records (P4-00~P4-05). See if the alarm exists with the encoder error (AL011, AL024, AL025, AL026)	Conduct the corrective actions of AL011, AL024, AL025, AL026
The output pulse exceeds the hardware allowable range.	Check if the following conditions produce: P1-76 < Motor Speed or $\frac{\text{Motor Speed}}{60} \times P1 - 46 \times 4 > 19.8 \times 10^6$	Correctly set parameter P1-76 and P1-46: P1-76 > Motor Speed or $\frac{\text{Motor Speed}}{60} \times P1 - 46 \times 4 < 19.8 \times 10^6$

AL019 : Serial Communication Error

Causes	Checking Method	Corrective Actions
Improper setting of the communication parameter	Check the setting value of communication parameter	Correctly set the parameter value
Incorrect communication address	Check the communication address	Correctly set the communication address
Incorrect communication value	Check the accessing value	Correctly set the value

AL020 : Serial Communication Time Out

Causes	Checking Method	Corrective Actions
Improper setting of the time-out parameter	Check the parameter setting	Correctly set the value
The drive hasn't received the communication command for a long time.	Check if the communication cable is loose or broken.	Correct wiring

AL021 : Reserved

AL022 : Main circuit power leak phase

Causes	Checking Method	Corrective Actions
The main circuit power is abnormal	Check if RST power cable is loose or does not connect to the power. This alarm occurs when no power connects to 3-phase for under 1.5 kW (included) servo drive. No power connects to single phase for 2 kW (included or above) servo drive, this alarm occurs.	Make sure it applies to the power. If issue persists, please send the drive back to the distributors or contact with Delta.

AL023 : Early warning for overload

Causes	Checking Method	Corrective Actions
Early warning for overload	<ol style="list-style-type: none"> 1. Check if it is used in overload condition. 2. Check if the value of parameter P1-56 is set to small. 	<ol style="list-style-type: none"> 1. Please refer to the corrective actions of AL006. 2. Please increase the setting value of parameter P1-56. Or set the value over 100 and deactivate the overload warning function.

AL024 : Encoder initial magnetic field error

Causes	Checking Method	Corrective Actions
The initial magnetic field is of the encoder in error (Signal, U, V, W of the encoder magnetic field is in error.)	<ol style="list-style-type: none"> 1. Check if the servo is properly grounded. 2. Check if the encoder cable separates from the power supply or the high-current circuit to avoid the interference. 3. Check if the shielding cables are used in the wiring of the encoder. 4. If it connects to Hall sensor, please check the wiring of Hall sensor. 	If issue persists, please send the drive back to the distributors or contact with Delta.

AL025**: The internal of the encoder is in error**

Causes	Checking Method	Corrective Actions
The internal of the encoder is in error. (The internal memory and the internal counter are in error)	<ol style="list-style-type: none"> 1. Check if the servo is properly grounded. 2. Check if the encoder cable separates from the power supply or the high-current circuit to avoid the interference. 3. Check if the shielding cables are used in the wiring of the encoder. 	<ol style="list-style-type: none"> 1. Please connect the UVW connector (color green) to the heat sink of the servo drive. 2. Please check if the encoder cable separates from the power supply or the high-current circuit. 3. Please use shielding mesh. 4. If issue persists, please send the drive back to the distributors or contact with Delta.

AL026**: Unreliable internal data of the encoder**

Causes	Checking Method	Corrective Actions
The encoder is in error. (Errors occur in the internal data for three times continuously)	<ol style="list-style-type: none"> 1. Check if the servo is properly grounded. 2. Check if the encoder cable separates from the power supply or the high-current circuit to avoid the interference. 3. Check if the shielding cables are used in the wiring of the encoder. 	<ol style="list-style-type: none"> 1. Please connect the UVW connector (color green) to the heat sink of the servo drive. 2. Please check if the encoder cable separates from the power supply or the high-current circuit. 3. Please use shielding mesh. 4. If issue persists, please send the drive back to the distributors or contact with Delta.

AL027**: Encoder reset error**

Causes	Checking Method	Corrective Actions
Reset the encoder	<ol style="list-style-type: none"> 1. If the contact of the signal cable is poor 2. If the encoder power is stable 3. If the operating temperature is higher than 95 °C 	<ol style="list-style-type: none"> 1. Make sure the signal cable is normal 2. Please use shielded net for encoder signal cable. 3. If issue persists, please send the drive back to the distributors or contact with Delta.

AL030 : Motor Crash Error

Causes	Checking Method	Corrective Actions
Motor Crash Error	<ol style="list-style-type: none"> 1. Check if P1-57 is enabled. 2. Check if P1-57 is set too small and the time of P1-58 is set too short. 	<ol style="list-style-type: none"> 1. If it is enabled by mistake, please set P1-57 to zero. 2. According to the actual torque setting, if the value is set too small, the alarm will be triggered by mistake. However, if the value is set too big, it will lose the function of protection.

AL031 : Incorrect wiring of the motor power line U, V, W, GND

Causes	Checking Method	Corrective Actions
The wiring of U, V, W, GND of the motor is incorrect connected.	Check if U, V, W of the motor is incorrect connected	Follow the user manual to correctly wire U, V, W and make sure it is grounded.

AL033 : Connection of 26 pin on converter box is breakdown

Causes	Checking Method	Corrective Actions
Connection of 26 pin on converter box is breakdown	<p>Check the status of converter box</p> <ol style="list-style-type: none"> 1. Switch mode Rotary switch at X1: AB pulse: Check if the connection of pin 1~6 on 26 pin is breakdown. Rotary switch at X2: SIN COS: Check if the connection of pin 8~13 on 26 pin is breakdown. 2. Drive mode The 1st bit of PM-03 = 0: Check if the connection of pin 1~6 on 26 pin is breakdown. The 1st bit of PM-03 = 1: Check if the connection of pin 8~13 on 26 pin is breakdown. 	Re-connect the breakdown part and then re-servo on will do.

AL035 : Motor Temperature Error

Causes	Checking Method	Corrective Actions
Motor temperature error	Check if the temperature of surrounding environment is over high	Reduce the temperature of surrounding environment

AL040 : Excessive deviation of full-closed loop position control

Causes	Checking Method	Corrective Actions
Excessive deviation of full closed-loop position control	<ol style="list-style-type: none"> 1. Check if P1-73 is set too small. 2. Check if the connector is loose or there is any connection problem of other mechanism. 	<ol style="list-style-type: none"> 1. Increase the value of P1-73. 2. Check if the connection is well connected.

AL041 : Communication of CN5 is breakdown

Causes	Checking Method	Corrective Actions
Communication of CN5 is breakdown	Check if the connection of pin1~5 and pin 9 on CN5 connector is breakdown.	Make sure the connection is correct and then re-servo on.

AL044 : Warning of servo drive function overload

Causes	Checking Method	Corrective Actions
Warning of servo drive function overload	N/A	Set Bit 4 of P2-66 to 1 could close the display of this alarm.

AL050 : Auto detection of motor parameters is completed

Causes	Checking Method	Corrective Actions
When executing the function of PM-01 (Automatic Identification of Motor Parameter), the alarm occurs when the auto detection is completed.	It informs users the detection is completed and should re-power on the servo drive.	Please re-power on the servo drive.

AL051

: Auto detection of motor parameters is in error

Causes	Checking Method	Corrective Actions
When executing the function of PM-01, if the friction is too big, motor is stuck or entering wrong resolution and pitch pole, this alarm will occur.	<ol style="list-style-type: none"> 1. Check if motor pole pitch, encoder resolution and encoder type are entered correctly. 2. Check if motor is stuck during detection. 3. Check if the motor friction is too big. 4. Check if the feedback of linear scale is abnormal, the connection is breakdown, the scale is not installed properly or there is noise interference. 	<ol style="list-style-type: none"> 1. Enter the value which is the same as the actual one and activate the detection again. 2. The rotary motor will rotate at forward and reverse direction for one magnetic cycle during detection. The linear motor will move for a pitch forward and backward. Please preserve the moving distance before detection. 3. Change another motor with more power. 4. Correct the problem of linear scale.

AL052

: Initial magnetic pole detection error

Causes	Checking Method	Corrective Actions
When motor does not connect to Hall sensor, it will search the initial magnetic pole when power on. If the initial magnetic pole is not found, this alarm will occur.	<ol style="list-style-type: none"> 1. Check if the feedback is normal 2. Check if the motor friction is too big 	Correct the problem of the encoder

AL053

: Motor parameter is not confirmed

Causes	Checking Method	Corrective Actions
If PM-02 = 0, this alarm occurs when motor servo On.		Make sure the motor parameter group is entered correctly. Set PM-02 to 1 and re-power on will do. After the detection procedure is completed, this parameter will be setup automatically.

AL054**: Exceeding the range of motor parameters**

Causes	Checking Method	Corrective Actions
When switching the motor type, if the setting value exceeds the range of PM-00, this alarm will occur.	<p>Check if the parameter is incorrect:</p> <p>Press the SHIFT Key to display EXGAB</p> <p>X = 1, 2, 3</p> <p>G = Parameter group code</p> <p>AB = Hex. Code of parameter</p> <p>E320A represents P2-10; E3610 represents P6-16; and E3D10 represents PM-16.</p>	The parameter setting range of linear motor is different from rotary motor. Please setup the correct parameter according to the motor type.

AL055**: Motor parameter is not confirmed**

Causes	Checking Method	Corrective Actions
When enabling the Y item of PM-09, servo will detect the motor's current magnetic field, and compare it with the position of Hall sensor's. When the deviation between both is too excessive, this alarm will occur.	<p>The servo drive monitors motor's magnetic field through the encoder, thus,</p> <ol style="list-style-type: none"> check if the feedback of encoder interferes the pulse loss because of the noise. assume that the feedback type of the encoder is square wave digital signal, check if the motor is over speed and exceeds the limit that hardware could take. The limit is 20Mhz (the resolution of quadruple frequency) check if Hall sensor is normal. 	<ol style="list-style-type: none"> Exclude the noise problem, if the type is square wave digital signal, users could filter out the noise through the proper setting of filter function. The setting of converter box =>PM-03 The setting of CN5 =>P1-74 Limit the max. speed of motor. Setup P1-55.

AL057**: Feedback pulse is lost**

Causes	Checking Method	Corrective Actions
When P2-81 = 1, it will check if pulse is lost. If the pulse loss amount exceeds the value of P2-82, this alarm will occur.	<ol style="list-style-type: none"> Check if the feedback of encoder interferes the pulse loss because of the noise. Assume that the feedback type of the encoder is square wave digital signal, check if the motor is over speed and exceeds the limit that hardware could take. The limit is 20Mhz (the resolution of quadruple frequency) 	<ol style="list-style-type: none"> Exclude the noise problem, if the type is square wave digital signal, users could filter out the noise through the proper setting of filter function. The setting of converter box =>PM-03 The setting of CN5 =>P1-74 Limit the max. speed of motor. Setup P1-55.

AL058

: Excessive deviation of initial magnetic pole detection position when power on

Causes	Checking Method	Corrective Actions
During initial magnetic pole detection, it will check if the position error exceeds the range. If yes, this alarm will occur.	<ol style="list-style-type: none"> 1. Check if the command is issued when power just on. 2. Check if the moving is too excessive during initial pole detection. 	<ol style="list-style-type: none"> 1. Do not issue the command right after the power is on. Users can issue the command until TPOS is On. 2. Reduce the value of PM-11. Reduce the detect current of initial pole.

AL067

: Motor Temperature Warning

Causes	Checking Method	Corrective Actions
Motor' s temperature will be over high	Check if the temperature of surrounding environment is over high	Reduce the temperature of surrounding environment

AL099

: DSP firmware upgrade

Causes	Checking Method	Corrective Actions
Upgrade DSP firmware	Check if the firmware is upgraded.	Firstly set P2-08 to 30. Then set P2-08 to 28, the alarm will be cleared when re-power on.

AL111

: CANopen SDO receives overflow

Causes	Checking Method	Corrective Actions
SDO Rx Buffer overflow (receives more than two SDOs within 1ms)	Check if the servo drive receives (sends) more than one SOD within 1ms.	NMT:Reset node 或 0x6040.Fault Reset

AL112

: CANopen PDO receives overflow

Causes	Checking Method	Corrective Actions
PDO Rx Buffer overflow (receives more than two PDOs of COBID within one millisecond)	Check if the servo drive receives (sends) more than one PDO of COBID within 1ms.	NMT: Reset node or 0x6040.Fault Reset

AL121

: Index error occurs when accessing CANopen PDO

Causes	Checking Method	Corrective Actions
The specified Index in the message does not exist.	Check if the Entry Index of PDO Mapping is modified when PDO is receiving or sending	NMT: Reset node or 0x6040.Fault Reset

AL 122 : Sub-Index error occurs when accessing CANopen PDO

Causes	Checking Method	Corrective Actions
The specified Sub-Index in the message does not exist.	Check if the Entry Sub-index of PDO Mapping is modified when PDO is receiving or sending.	NMT: Reset node or 0x6040.Fault Reset

AL 123 : Data Size error occurs when accessing CANopen PDO

Causes	Checking Method	Corrective Actions
The data length in the message does not match to the specified object.	Check if the data length of Entry of PDO Mapping is modified when PDO is receiving or sending.	NMT: Reset node or 0x6040.Fault Reset

AL 124 : Data range error occurs when accessing CANopen PDO

Causes	Checking Method	Corrective Actions
The data value in the message is over the range of the specified object.	Check if the written range is wrong when PDO is receiving or sending.	NMT: Reset node or 0x6040.Fault Reset

AL 125 : CANopen PDO Object is read-only and write-protected

Causes	Checking Method	Corrective Actions
The specified object in the message is write-protected.	Check if the specified object is read-only when PDO is receiving or sending.	NMT: Reset node or 0x6040.Fault Reset

AL 126 : CANopen PDO Object is not allowed in PDO

Causes	Checking Method	Corrective Actions
The specified object in the message does not support PDO.	Check if the specified object allows PDO Mapping when PDO is receiving or sending.	NMT: Reset node or 0x6040.Fault Reset

AL 127 : CANopen PDO Object is write-protected when Servo On

Causes	Checking Method	Corrective Actions
The specified object in the message is write-protected when Servo ON	Check that when PDO is receiving or sending, if the specified object is write-protected when Servo On.	NMT: Reset node or 0x6040.Fault Reset

AL 128

: Error occurs when reading CANopen PDO object via EEPROM

Causes	Checking Method	Corrective Actions
An error occurs when loading the default value via ROM at start-up. All objects of CAN returns to the default value automatically.	When PDO is receiving or sending, check if the error occurs because the specified object reads EEPROM.	NMT: Reset node or 0x6040.Fault Reset

AL 129

: Error occurs when writing CANopen PDO object via EEPROM

Causes	Checking Method	Corrective Actions
An error occurs when saving the current value into ROM.	When PDO is receiving or sending, check if the error occurs because the specified object is wrote into EEPROM	NMT: Reset node or 0x6040.Fault Reset

AL 130

: The accessing address of EEPROM is out of range when using CANopen PDO object

Causes	Checking Method	Corrective Actions
The quantity of the data inside ROM is over the planned space. It is probably because the software has been updated. The data inside ROM is stored by the old version. Thus, it cannot be used.	Check that when PDO is receiving or sending, if the specified object enables EEPROM address exceeds the limit.	NMT: Reset node or 0x6040.Fault Reset

AL 131

: CRC of EEPROM calculation error occurs when using CANopen PDO object

Causes	Checking Method	Corrective Actions
It means the data stored in ROM is damaged. All CANopen objects automatically returns to the default value.	Check if the specified object would cause CRC calculation error in EEPROM when PDO is receiving or sending.	NMT: Reset node or 0x6040.Fault Reset

AL 132**: Enter the incorrect password when using CANopen PDO object**

Causes	Checking Method	Corrective Actions
When entering parameters via CAN, parameters are password-protected. Users have to decode the password first.	Check if the specified object enters the wrong password when PDO is receiving or sending.	NMT: Reset node or 0x6040.Fault Reset

AL 185**: Abnormal CAN Bus hardware**

Causes	Checking Method	Corrective Actions
Abnormal CAN Bus hardware	<ol style="list-style-type: none"> 1. Check if the communication cable of CAN Bus is good. 2. Check if the communication quality is good. (It is suggested to use common grounding and shielded cable) 	NMT: Reset node or re-servo on

AL 201**: An error occurs when loading CANopen data**

Causes	Checking Method	Corrective Actions
An error occurs when loading CANopen data	<ol style="list-style-type: none"> 1. If the alarm is cleared when re-servo on, it means the data error occurs instantaneously when accessing in the previous time. 2. If the error still exists after re-servo on, it means the data in EEPROM is damaged. It has to enter the correct value again. The method is as the followings: <ol style="list-style-type: none"> a. If the user desires to enter the default value, it can set P2-08 to 30, 28 or CANopen object as 0x1011. b. If the user desires to enter the current value, it can set CANopen object to 0x1010. (Please refer to CANopen description.) 	DI:ARST, CANopen 0x1011 Restore default parameter

AL213 ~ AL217 : An error occurs when writing parameter via PR

Causes	Checking Method	Corrective Actions
PR commands TYPE 8 Error occurs when writing parameters	AL213 : parameter exceeds the range	DI : Alm Reset or P0-01 = 0
	AL215 : the parameter is read-only	
	AL217 : Servo On or invalid value	Re-adjust PR command and parameters

AL235 : PR command overflows

Causes	Checking Method	Corrective Actions
PR command overflows	PR mode continuously operates in one direction and causes feedback register overflows. And the coordinate system cannot reflect the correct position. If issuing the absolute positioning command (except incremental) at this time, the error will occur.	NMT: Reset node or 0x6040.Fault Reset

AL245 : PR positioning is over time

Causes	Checking Method	Corrective Actions
PR positioning is over time	This alarm will not occur at the moment. If it does, please contact the distributors.	NMT: Reset node or 0x6040.Fault Reset

AL249 : The number of PR command exceeds the range

Causes	Checking Method	Corrective Actions
The number of PR command exceeds the range	This alarm will not occur at the moment. If it does, please contact the distributors.	NMT: Reset node or 0x6040.Fault Reset

AL261 : Index error occurs when accessing CANopen object

Causes	Checking Method	Corrective Actions
The specified Index in the message does not exist.	This alarm will not occur at the moment. If it does, please contact the distributors.	NMT: Reset node or 0x6040.Fault Reset

AL263**: Sub-Index error occurs when accessing CANopen object**

Causes	Checking Method	Corrective Actions
The specified Sub-Index in the message does not exist.	This alarm will not occur at the moment. If it does, please contact the distributors.	NMT: Reset node or 0x6040.Fault Reset

AL265**: Data size error occurs when accessing CANopen object**

Causes	Checking Method	Corrective Actions
The data length in the message does not match to the specified object.	This alarm will not occur at the moment. If it does, please contact the distributors.	NMT: Reset node or 0x6040.Fault Reset

AL267**: Data range error occurs when accessing CANopen object**

Causes	Checking Method	Corrective Actions
The data in the message is over the range of the specified object.	This alarm will not occur at the moment. If it does, please contact the distributors.	NMT: Reset node or 0x6040.Fault Reset

AL269**: CANopen object is read-only and write-protected**

Causes	Checking Method	Corrective Actions
The specified object in the message is write-protected.	This alarm will not occur at the moment. If it does, please contact the distributors.	NMT: Reset node or 0x6040.Fault Reset

AL266**: CANopen PDO Object is not allowed in PDO**

Causes	Checking Method	Corrective Actions
The specified object in the message does not support PDO	This alarm will not occur at the moment. If it does, please contact the distributors.	NMT: Reset node or 0x6040.Fault Reset

AL264**: CANopen object is write-protected when Servo On**

Causes	Checking Method	Corrective Actions
The specified object in the message is write-protected when Servo ON	This alarm will not occur at the moment. If it does, please contact the distributors.	NMT: Reset node or 0x6040.Fault Reset

AL26F

: Error occurs when reading CANopen object via EEPROM

Causes	Checking Method	Corrective Actions
An error occurs when loading the default value via ROM at start-up. All objects of CAN returns to the default value automatically.	This alarm will not occur at the moment. If it does, please contact the distributors.	NMT: Reset node or 0x6040.Fault Reset

AL271

: Error occurs when writing CANopen object via EEPROM

Causes	Checking Method	Corrective Actions
An error occurs when saving the current value into ROM	This alarm will not occur at the moment. If it does, please contact the distributors.	NMT: Reset node or 0x6040.Fault Reset

AL273

: The accessing address of EEPROM is out of range when using CANopen object

Causes	Checking Method	Corrective Actions
The quantity of the data inside ROM is over the planned space. It is probably because the software has been updated. The data inside ROM is stored by the old version. Thus, it cannot be used.	This alarm will not occur at the moment. If it does, please contact the distributors.	NMT: Reset node or 0x6040.Fault Reset

AL275

: CRC of EEPROM calculation error occurs when using CANopen object

Causes	Checking Method	Corrective Actions
It indicates that the data stored in ROM has been damaged. All objects of CAN will return to the default settings automatically.	This alarm will not occur at the moment. If it does, please contact the distributors.	NMT: Reset node or 0x6040.Fault Reset

AL277**: Enter the incorrect password when using CANopen object**

Causes	Checking Method	Corrective Actions
When entering parameters via CAN, the parameters are password-protected. Users have to decode the password first.	This alarm will not occur at the moment. If it does, please contact the distributors.	NMT: Reset node or 0x6040.Fault Reset

AL283**: Forward Software Limit**

Causes	Checking Method	Corrective Actions
Forward software limit	Forward Software Limit is determined by the position command, not the actual feedback position. It is because the command will arrive first and then the feedback. When the protection function is activated, the actual position might not over the limit. Therefore, setting an appropriate decelerating time could satisfy the demand. Please refer to the description of parameter P5-03.	NMT: Reset node or 0x6040.Fault Reset

AL285**: Reverse Software Limit**

Causes	Checking Method	Corrective Actions
Reverse software limit	Reverse Software Limit is determined by the position command, not the actual feedback position. It is because the command will arrive first and then the feedback. When the protection function is activated, the actual position might not over the limit. Therefore, setting an appropriate decelerating time could satisfy the demand. Please refer to the description of parameter P5-03.	NMT: Reset node or 0x6040.Fault Reset

AL289**: Feedback position counter overflows**

Causes	Checking Method	Corrective Actions
Feedback position counter overflows	This alarm will not occur at the moment. If it does, please contact the distributors.	NMT: Reset node or 0x6040.Fault Reset

AL291 : Servo Off error

Causes	Checking Method	Corrective Actions
Servo Off error	<ol style="list-style-type: none"> 1. Check if the wiring of DI.SERVO ON is correct 2. Check if the controller servo on the drive too early. 	NMT: Reset node or 0x6040.Fault Reset

AL301 : CANopen fails to synchronize

Causes	Checking Method	Corrective Actions
CANopen fails to synchronize	<ol style="list-style-type: none"> 1. Check if the communication quality of the circuit is bad. 2. Check if the controller sends SYNC signal successfully. 3. Check if the setting of P3-09 is reasonable. (It is better to use the default value) 	NMT: Reset node or 0x6040.Fault Reset

AL302 : The synchronized signal of CANopen is sent too fast

Causes	Checking Method	Corrective Actions
The synchronized signal of CANopen is sent too fast	<ol style="list-style-type: none"> 1. Check if synchronized cycle 0x1006 is the same as the setting of controller. 2. Check if the setting of P3-09 is reasonable. (It is better to use the default value) 3. Check if the order of controller is incorrect. 	NMT: Reset node or 0x6040.Fault Reset

AL303 : The synchronized signal of CANopen is sent too slow

Causes	Checking Method	Corrective Actions
The synchronized signal of CANopen is sent too slow	<ol style="list-style-type: none"> 1. Check if the communication quality of the circuit is bad. 2. Check if synchronized cycle 0x1006 is the same as the setting of controller. 3. Check if the setting of P3-09 is reasonable. (It is better to use the default value) 4. Check if the order of controller is incorrect. 	NMT: Reset node or 0x6040.Fault Reset

AL 304 : CANopen IP command fails

Causes	Checking Method	Corrective Actions
CANopen IP command fails	The calculating time of IP mode takes too long. Please disable USB monitoring function.	NMT: Reset node or 0x6040.Fault Reset

AL 305 : SYNC Period is in error

Causes	Checking Method	Corrective Actions
SYNC Period is in error	Examine the content of 0x1006.If it is smaller than or equals to 0, the alarm will occur.	NMT: Reset node or 0x6040.Fault Reset

AL 380 : Position Deviation Alarm

Causes	Checking Method	Corrective Actions
DO.MC_OK is ON and becomes OFF.	Please refer to the description of parameter P1-48. After DO.MC_OK ON, DO.MC_OK becomes OFF because DO.TPOS turns OFF. The position of the motor might be deviated by the external force after positioning. This alarm can be cleared by P1-48.Y=0.	DI : Alm Reset or P0-01= 0

10.5 Corrective Actions after the Alarm Occurs

AL001	: Over current	Turn DI.ARST on to clear the alarm
AL002	: Over voltage	Turn DI.ARST on to clear the alarm
AL003	: Under voltage	The alarm can be cleared after the voltage returns to normal.
AL004	: The magnetic field of the motor is abnormal	The alarm can be cleared after re-power on.
AL005	: Regeneration error	Turn DI.ARST on to clear the alarm
AL006	: Overload	Turn DI.ARST on to clear the alarm
AL007	: Excessive speed deviation	Turn DI.ARST on to clear the alarm
AL008	: Abnormal pulse command	Turn DI.ARST on to clear the alarm
AL009	: Excessive deviation of position control	Turn DI.ARST on to clear the alarm
AL011	: Encoder error	The alarm can be cleared after re-power on.
AL012	: Adjustment error	The alarm can be cleared when removing CN1 wiring and execute auto adjustment.
AL013	: Emergency stop	The alarm can be cleared automatically after turning DI.EMGS off
AL014	: Reverse limit error	Turn DI.ARST on or Servo Off to clear the alarm. The alarm also can be cleared when the motor operates backwards.
AL015	: Forward limit error	Turn DI.ARST on or Servo Off to clear the alarm. The alarm also can be cleared when the motor operates backwards.
AL016	: The temperature of IGBT is abnormal	Turn DI.ARST on to clear the alarm
AL017	: Abnormal EEPROM	If the alarm occurs, then parameter reset is a must. And re-servo on again. If it happens during the operation, please turn DI.ARST on to clear the alarm.
AL018	: Abnormal signal output	Turn DI.ARST on to clear the alarm
AL019	: Serial communication error	Turn DI.ARST on to clear the alarm
AL020	: Serial communication timeout	Turn DI.ARST on to clear the alarm
AL022	: Main circuit power leak phase	Turn DI.ARST on to clear the alarm
AL023	: Early warning for overload	Turn DI.ARST on to clear the alarm

AL024	: Encoder initial magnetic field error	The alarm can be cleared after re-power on.
AL025	: The internal of the encoder is in error	The alarm can be cleared after re-power on.
AL026	: The encoder is in error	The alarm can be cleared after re-power on.
AL030	: Motor crash error	Turn DI.ARST on to clear the alarm
AL031	: Incorrect wiring of the motor power line U, V, W, GND	The alarm can be cleared after re-power on.
AL033	: Connection of 26 pin on converter box is breakdown	The alarm can be cleared after re-power on.
AL035	: Motor temperature error	The alarm can be cleared after re-power on.
AL040	: Excessive deviation of full closed-loop position control	Turn DI.ARST on to clear the alarm
AL041	: Communication of CN5 is breakdown	The alarm can be cleared after re-power on.
AL044	: Warning of servo drive function	Set Bit 4 of P2-66 to 1 and re-power on will do.
AL050	: Auto detection of motor parameters is completed	The alarm can be cleared after re-power on.
AL051	: Auto detection of motor parameters is in error	Turn DI.ARST on to clear the alarm
AL052	: Initial magnetic pole detection error	Turn DI.ARST on to clear the alarm
AL053	: Motor parameter is not confirmed	Set PM-02 to 1 and re-power on. The alarm will be cleared automatically.
AL054	: Exceeding the range of motor parameter	Correctly setup the parameter and re-power on. The alarm will be cleared automatically.
AL055	: Motor magnetic field error	The alarm can be cleared after re-power on.
AL057	: Motor magnetic field error	The alarm can be cleared after re-power on.
AL058	: Motor magnetic field error	Turn DI.ARST on to clear the alarm
AL057	: Motor temperature warning	The alarm will be cleared when the temperature recovers
AL099	: DSP firmware upgrade	Firstly set P2-08 to 30. Then set it to 28. And the alarm will be cleared after re-power on.
AL111	: CANopen SDO receives buffer overflow	NMT: Reset node or 0x6040.Fault Reset
AL112	: CANopen PDO receives buffer overflow	NMT: Reset node or 0x6040.Fault Reset

AL 121	: Index error occurs when accessing CANopen PDO	NMT: Reset node or 0x6040.Fault Reset
AL 122	: Sub-Index error occurs when accessing CANopen PDO	NMT: Reset node or 0x6040.Fault Reset
AL 123	: Sub-Index error occurs when accessing CANopen PDO	NMT: Reset node or 0x6040.Fault Reset
AL 124	: Data range error occurs when accessing CANopen PDO	NMT: Reset node or 0x6040.Fault Reset
AL 125	: CANopen PDO object is read-only and write-protected.	NMT: Reset node or 0x6040.Fault Reset
AL 126	: CANopen PDO object is not allowed in PDO	NMT: Reset node or 0x6040.Fault Reset
AL 127	: CANopen PDO object is write-protected when Servo On	NMT: Reset node or 0x6040.Fault Reset
AL 128	: Error occurs when reading CANopen PDO object via EEPROM	NMT: Reset node or 0x6040.Fault Reset
AL 129	: Error occurs when writing CANopen PDO object via EEPROM	NMT: Reset node or 0x6040.Fault Reset
AL 130	: The accessing address of EEPROM is out of range when using CANopen PDO object	NMT: Reset node or 0x6040.Fault Reset
AL 131	: CRC of EEPROM calculation error occurs when using CANopen PDO object	NMT: Reset node or 0x6040.Fault Reset
AL 132	: Enter the incorrect password when using CANopen PDO object	NMT: Reset node or 0x6040.Fault Reset
AL 185	: Abnormal CAN Bus hardware	NMT:Reset node or re-servo on
AL 201	: An error occurs when loading CANopen data	Turn DI.ARST on to clear the alarm, CANopen 0x1011 Restore default parameter
AL 213	: An error occurs when writing parameter via PR : exceeds the range	DI.Alm Reset or P0-01 = 0
AL 215	: An error occurs when writing parameter via PR : read-only	DI.Alm Reset or P0-01 = 0

AL217	: An error occurs when writing parameter via PR : parameter locked	Re-adjust PR command and parameter
AL235	: PR command overflows	NMT: Reset node or 0x6040.Fault Reset
AL245	: PR positioning is over time	NMT: Reset node or 0x6040.Fault Reset
AL249	: The number PR command exceeds the range	NMT: Reset node or 0x6040.Fault Reset
AL261	: Index error occurs when accessing CANopen object	NMT: Reset node or 0x6040.Fault Reset
AL263	: Sub-Index error occurs when accessing CANopen object	NMT: Reset node or 0x6040.Fault Reset
AL265	: Data Size error occurs when accessing CANopen object	NMT: Reset node or 0x6040.Fault Reset
AL267	: Data range error occurs when accessing CAN.	NMT: Reset node or 0x6040.Fault Reset
AL269	: CANopen object is read-only and write-protected	NMT: Reset node or 0x6040.Fault Reset
AL26b	: PDO is not allowed in CANopen object	NMT: Reset node or 0x6040.Fault Reset
AL26d	: CANopen object is write-protected when Servo On	NMT: Reset node or 0x6040.Fault Reset
AL26f	: Error occurs when reading CANopen object via EEPROM	NMT: Reset node or 0x6040.Fault Reset
AL271	: Error occurs when writing CANopen object via EEPROM	NMT: Reset node or 0x6040.Fault Reset
AL273	: The accessing address of EEPROM is out of range when using CANopen object	NMT: Reset node or 0x6040.Fault Reset
AL275	: CRC of EEPROM calculation error occurs when using CANopen object	NMT: Reset node or 0x6040.Fault Reset
AL277	: Enter the incorrect password when using CANopen object	NMT: Reset node or 0x6040.Fault Reset
AL283	: Forward Software Limit	NMT: Reset node or 0x6040.Fault Reset
AL285	: Reverse Software Limit	NMT: Reset node or 0x6040.Fault Reset



AL 289	: Feedback position counter overflows	NMT: Reset node or 0x6040.Fault Reset
AL 291	: Servo Off error	NMT: Reset node or 0x6040.Fault Reset
AL 301	: CANopen fails to synchronize	NMT: Reset node or 0x6040.Fault Reset
AL 302	: The synchronized signal of CANopen is sent too fast	NMT: Reset node or 0x6040.Fault Reset
AL 303	: The synchronized signal of CANopen is sent too slow	NMT: Reset node or 0x6040.Fault Reset
AL 304	: CANopen IP command is failed	NMT: Reset node or 0x6040.Fault Reset
AL 305	: SYNC Period is in error	NMT: Reset node or 0x6040.Fault Reset
AL 380	: Position Deviation Alarm	DI:Alm Reset or P0-01 = 0

Chapter 11 Specifications

11.1 Specifications of Servo Drive

ASDA-A2R Series		100 W	200 W	400 W	750 W	1 kW	1.5 kW	2 kW	3 kW	
		01	02	04	07	10	15	20	30	
Power	Phase / Voltage	Single phase/ Three phase 220 VAC						Three phase 220 VAC		
	Permissible voltage	Single phase/ Three phase 200 ~ 230 VAC, -15%~10%						Three phase 200 ~ 230 VAC, -15%~10%		
	Continuous output current	0.9 Arms	1.55 Arms	2.6 Arms	5.1 Arms	7.3 Arms	8.3 Arms	13.4 Arms	19.4 Arms	
Cooling method		Natural cooling			Fan cooling					
Encoder resolution / Feedback resolution (for Delta's 20BIT rotary motor)		20-bit (1280000 p/rev)								
Main circuit control		SVPWM control								
Control mode		Manual / Auto								
Regenerative resistor		N/A			Built-in					
Position Control Mode	Max. input pulse frequency	Transmitted by differential: 500K/4Mpps, transmitted by open-collector: 200Kpps								
	Pulse type	Pulse + symbol; A phase + B phase; CCW pulse + CW pulse								
	Command source	External pulse / Register								
	Smoothing strategy	Low-pass and P-curve filter								
	E-gear ratio	E-gear ratio: N / M time, limitation: (1/50 < N/M < 25600) N: 1~32767 / M: 1:32767								
	Torque limit	Parameter settings								
	Feed forward compensation	Parameter settings								
Speed Control Mode	Analog command input	Voltage range	0 ~ ±10 V _{DC}							
		Input resistance	10 KΩ							
		Time constant	2.2 us							
	Speed control range*1	1:5000								
	Command source	External analog command / Register								
	Smoothing strategy	Low-pass and S-curve filter								

ASDA-A2R Series		100 W	200 W	400 W	750 W	1 kW	1.5 kW	2 kW	3 kW
		01	02	04	07	10	15	20	30
	Torque limit		Via parameter setting or analog input						
	Bandwidth		Max.1kHz						
	Speed accuracy*2		The load fluctuation (0 ~ 100%) is 0.01%						
			The power fluctuation ±10% is 0.01%						
		The ambient temperature fluctuation (0 ~ 50°C) is 0.01%							
Torque control mode	Analog command input	Voltage range	0 ~ ±10 V _{DC}						
		Input resistance	10 KΩ						
		Time constant	2.2 us						
	Command source		External analog command / Register						
	Smoothing strategy		Low-pass filter						
	Speed limit		Via parameter setting or analog input						
	Analog monitor output		The monitor signal which can be set via parameters (Output voltage range: ±8 V)						
Digital Input/Output		Input	Servo on, Fault reset, Gain switch, Pulse clear, Zero clamp, Command input reverse control, Internal position command trigger, Torque (force) limit, Speed limit, Internal position command selection, Motor stop, Speed command selection, Speed / position mode switching, Speed / torque (force) mode switching, Torque (force) / position mode switching, Pt / Pr command switching, Emergency stop, Positive / negative limit, Original point, Forward / reverse operation torque limit, Homing activated, E-CAM engage, Forward / reverse JOG input, Event trigger, E-gear N selection, Pulse input prohibition						
		Output	A, B, Z Line Driver output Servo on, Servo ready, Zero speed, Target speed reached, Target position reached, torque (force) limiting, Servo alarm, Brake control, Homing completed, Early warning for overload, Servo warning, Position command overflows, Software negative limit, Software positive limit, Internal position command completed, Capture procedure completed, Servo procedure completed, Master position area of E-CAM						
Protective function		Over current, Overvoltage, Undervoltage, Overheat, Regeneration error, Overload, Excessive speed deviation, Excessive position deviation, Encoder error, Adjustment error, Emergency stop, Negative / positive limit error, Excessive deviation of full-closed loop control, Serial communication error, Rst leak phase, Serial communication timeout, Short-circuit protection of terminal U, V, W and CN1, CN2, CN3							
Communication interface		RS-485 / CANopen / USB							
Environment	Installation site		Indoors (avoid the direct sunlight), no corrosive fog (avoid fume, flammable gas and dust)						
	Altitude		Elevation under 1000M						
	Atmospheric pressure		86kPa ~ 106kPa						
	Operating temperature		0°C ~ 55°C(If the temperature is over 45°C, forced air circulation is needed.)						
	Storage temperature		-20°C ~ 65°C						
	Humidity		Under 0 ~ 90% RH (non-condensing)						

Vibrating	Under 20Hz, 9.80665m/s ² (1G), 20 ~ 50Hz 5.88m/ s ² (0.6G)
IP rating	IP20
Power system	TN system* ⁴
Approvals	IEC/EN 61800-5-1, UL 508C, C-tick   



Note:

- *1 When it is in rated load, the speed ratio is: the minimum speed (smooth operation) /rated speed.
- *2 When the command is the rated speed, the velocity correction ratio is: (rotational speed with no load – rotational speed with full load) / rated speed.
- *3 Please refer to section 11.6 for overload features.
- *4 TN system: The neutral point of the power system connects to the ground directly. The exposed metal components connect to the ground via the protective earth conductor.

11.2 Specifications of Servo Motor (ECMA Series)

Low inertia series

ECMA	C104	C△04	C△06		C△08		C△09	
	0F	01	02	04	04	07	07	10
Rated power (kW)	0.05	0.1	0.2	0.4	0.4	0.75	0.75	1.0
Rated torque (N-m)*1	0.159	0.32	0.64	1.27	1.27	2.39	2.39	3.18
Max. torque (N-m)	0.477	0.96	1.92	3.82	3.82	7.16	7.14	8.78
Rated speed (r/min)	3000						3000	
Max. speed (r/min)	5000						3000	
Rated current (A)	0.69	0.90	1.55	2.60	2.60	5.10	3.66	4.25
Max. instantaneous current (A)	2.05	2.70	4.65	7.80	7.80	15.3	11	12.37
Max. power per second (kW/s)	12.27	27.7	22.4	57.6	24.0	50.4	29.6	38.6
Rotor inertia ($\times 10^{-4}$ kg.m ²)	0.0206	0.037	0.177	0.277	0.68	1.13	1.93	2.62
Mechanical constant (ms)	1.14	0.75	0.80	0.53	0.74	0.63	1.72	1.20
Torque constant – KT(N-m/A)	0.23	0.36	0.41	0.49	0.49	0.47	0.65	0.75
Voltage constant – KE (mV/(r/min))	9.8	13.6	16.0	17.4	18.5	17.2	24.2	27.5
Armature resistance (Ohm)	12.7	9.30	2.79	1.55	0.93	0.42	1.34	0.897
Armature inductance (mH)	26	24.0	12.07	6.71	7.39	3.53	7.55	5.7
Electric constant (ms)	2.05	2.58	4.30	4.30	7.96	8.36	5.66	6.35
Insulation class	Class A (UL), Class B (CE)							
Insulation resistance	> 100MΩ, DC 500V							
Insulation strength	1.8k Vac,1 sec							
Weight – without brake (kg)	0.42	0.5	1.2	1.6	2.1	3.0	2.9	3.8
Weight – with brake (kg)	--	0.8	1.5	2.0	2.9	3.8	3.69	5.5
Radial max. loading (N)	78.4	78.4	196	196	245	245	245	245
Axial max. loading (N)	39.2	39.2	68	68	98	98	98	98
Max. power per second (kW/s) (with brake)	--	25.6	21.3	53.8	22.1	48.4	29.3	37.9
Rotor inertia ($\times 10^{-4}$ kg.m ²) (with brake)	--	0.04	0.19	0.30	0.73	1.18	1.95	2.67
Mechanical constant (ms) (with brake)	--	0.81	0.85	0.57	0.78	0.65	1.74	1.22
Brake holding torque [Nt-m (min)]*2	--	0.3	1.3	1.3	2.5	2.5	2.5	2.5
Brake power consumption (at 20°C) [W]	--	7.3	6.5	6.5	8.2	8.2	8.2	8.2
Brake release time [ms (Max)]	--	5	10	10	10	10	10	10
Brake pull-in time [ms (Max)]	--	25	70	70	70	70	70	70

ECMA	C104	C△04	C△06		C△08		C△09	
	0F	01	02	04	04	07	07	10
Vibration grade (μm)	15							
Operating temperature (°C)	0°C ~ 40°C							
Storage temperature (°C)	-10°C ~ 80°C							
Operating humidity	20 ~ 90%RH (non-condensing)							
Storage humidity	20 ~ 90%RH (non-condensing)							
Vibration capacity	2.5G							
IP Rating	IP65 (use the waterproof connector and shaft seal installation (or oil seal))							
Approvals	 							

Note:

*1 The rated torque is the continuous permissible torque between 0~40°C operating temperature which is suitable for the following heat sink dimension.

ECMA-__ 04 / 06 / 08 : 250mm x 250mm x 6mm

ECMA-__ 10 : 300mm x 300mm x 12mm

ECMA-__ 13 : 400mm x 400mm x 20mm



ECMA-__ 18 : 550mm x 550mm x 30mm

Material: Aluminum – F40, F60, F80, F100, F130, F180

*2 The built-in brake of the servo motor is for remaining the item in stop status. Do not use it to decelerate or as the dynamic brake.

Low inertia series

ECMA	C△10		C△13
	10	20	30
Rated power (kW)	1.0	2.0	3.0
Rated torque (N-m) ^{*1}	3.18	6.37	9.55
Max. torque (N-m)	9.54	19.1	28.65
Rated speed (r/min)	3000		3000
Max. speed (r/min)	5000		4500
Rated current (A)	7.30	12.05	17.2
Max. instantaneous current (A)	21.9	36.15	47.5
Max. power per second (kW/s)	38.1	90.6	71.8
Rotor inertia (× 10 ⁻⁴ kg.m ²)	2.65	4.45	12.7
Mechanical constant (ms)	0.74	0.61	1.11
Torque constant – KT(N-m/A)	0.44	0.53	0.557
Voltage constant – KE (mV/(r/min))	16.8	19.2	20.98
Armature resistance (Ohm)	0.20	0.13	0.0976
Armature inductance (mH)	1.81	1.50	1.21
Electric constant (ms)	9.30	11.4	12.4
Insulation class	Class A (UL), Class B (CE)		
Insulation resistance	> 100MΩ, DC 500V		
Insulation strength	1.8k Vac,1 sec		
Weight – without brake (kg)	4.3	6.2	7.8
Weight – with brake (kg)	4.7	7.2	9.2
Radial max. loading (N)	490	490	490
Axial max. loading (N)	98	98	98
Max. power per second (kW/s) (with brake)	30.4	82.0	65.1
Rotor inertia (× 10 ⁻⁴ kg.m ²) (with brake)	3.33	4.95	14.0
Mechanical constant (ms) (with brake)	0.93	0.66	1.22
Brake holding torque [Nt-m (min)] ^{*2}	8.0	8.0	10.0
Brake power consumption (at 20°C) [W]	19.4	19.4	19.0
Brake release time [ms (Max)]	10	10	10
Brake pull-in time [ms (Max)]	70	70	70

ECMA	C△10		C△13
	10	20	30
Vibration grade (μm)	15		
Operating temperature (°C)	0°C ~ 40°C		
Storage temperature (°C)	-10°C ~ 80°C		
Operating humidity	20 ~ 90%RH (non-condensing)		
Storage humidity	20 ~ 90%RH (non-condensing)		
Vibration capacity	2.5G		
IP Rating	IP65 (use the waterproof connector and shaft seal installation (or oil seal) model)		
Approvals	 		

Note:

*1 The rated torque is the continuous permissible torque between 0~40°C operating temperature which is suitable for the following heat sink dimension.

ECMA-__ 04 / 06 / 08 : 250mm x 250mm x 6mm

ECMA-__ 10 : 300mm x 300mm x 12mm

ECMA-__ 13 : 400mm x 400mm x 20mm



ECMA-__ 18 : 550mm x 550mm x 30mm

Material: Aluminum – F40, F60, F80, F100, F130, F180

*2 The built-in brake of the servo motor is for remaining the item in stop status. Do not use it to decelerate or as the dynamic brake.

Medium / High inertia series

ECMA	E△13				E△18			G△13		
	05	10	15	20	20	30	35	03	06	09
Rated power (kW)	0.5	1.0	1.5	2.0	2.0	3.0	3.5	0.3	0.6	0.9
Rated torque (N-m)*1	2.39	4.77	7.16	9.55	9.55	14.32	16.71	2.86	5.73	8.59
Max. torque (N-m)	7.16	14.3	21.48	28.65	28.65	42.97	50.13	8.59	17.19	21.48
Rated speed (r/min)	2000							1000		
Max. speed (r/min)	3000							2000		
Rated current (A)	2.9	5.6	8.3	11.01	11.22	16.1	19.2	2.5	4.8	7.5
Max. instantaneous current (A)	8.7	16.8	24.9	33.03	33.66	48.3	57.6	7.5	14.4	22.5
Max. power per second (kW/s)	7.0	27.1	45.9	62.5	26.3	37.3	50.8	10.0	39.0	66.0
Rotor inertia (× 10 ⁻⁴ kg.m ²)	8.17	8.41	11.18	14.59	34.68	54.95	54.95	8.17	8.41	11.18
Mechanical constant (ms)	1.91	1.51	1.10	0.96	1.62	1.06	1.08	1.84	1.40	1.06
Torque constant – KT(N-m/A)	0.83	0.85	0.87	0.87	0.85	0.89	0.87	1.15	1.19	1.15
Voltage constant – KE (mV/(r/min))	30.9	31.9	31.8	31.8	31.4	32.0	32	42.5	43.8	41.6
Armature resistance (Ohm)	0.57	0.47	0.26	0.174	0.119	0.052	0.052	1.06	0.82	0.43
Armature inductance (mH)	7.39	5.99	4.01	2.76	2.84	1.38	1.38	14.29	11.12	6.97
Electric constant (ms)	12.96	12.88	15.31	15.86	23.87	26.39	26.39	13.55	13.50	16.06
Insulation class	Class A (UL), class B (CE)									
Insulation resistance	> 100MΩ, DC 500V									
Insulation strength	1.8k Vac, 1 sec									
Weight – without brake (kg)	6.8	7.0	7.5	7.8	13.5	18.5	18.5	6.8	7.0	7.5
Weight – with brake (kg)	8.2	8.4	8.9	9.2	17.5	22.5	22.5	8.2	8.4	8.9
Radial max. loading (N)	490	490	490	490	1176	1470	490	490	490	490
Axial max. loading (N)	98	98	98	98	490	490	98	98	98	98
Max. power per second (kW/s) (with brake)	6.4	24.9	43.1	59.7	24.1	35.9	48.9	9.2	35.9	62.1
Rotor inertia (× 10 ⁻⁴ kg.m ²) (with brake)	8.94	9.14	11.90	15.88	37.86	57.06	57.06	8.94	9.14	11.9
Mechanical constant (ms) (with brake)	2.07	1.64	1.19	1.05	1.77	1.10	1.12	2.0	1.51	1.13
Brake holding torque [Nt-m (min)]*2	10.0	10.0	10.0	10.0	25.0	25.0	10.0	10.0	10.0	10.0
Brake power consumption (at 20°C) [W]	19.0	19.0	19.0	19.0	20.4	20.4	19.0	19.0	19.0	19.0
Brake release time [ms (Max)]	10	10	10	10	10	10	10	10	10	10
Brake pull-in time [ms (Max)]	70	70	70	70	70	70	70	70	70	70

ECMA	E△13				E△18			G△13		
	05	10	15	20	20	30	35	03	06	09
Vibration grade (μm)	15									
Operating temperature (°C)	0°C ~ 40°C									
Storage temperature (°C)	-10°C ~ 80°C									
Operating humidity	20 ~ 90%RH (non-condensing)									
Storage humidity	20 ~ 90%RH (non-condensing)									
Vibration capacity	2.5G									
IP Rating	IP65 (use the waterproof connector and shaft seal installation (or oil seal) model)									
Approvals	 									

Note:

*1 The rated torque is the continuous permissible torque between 0~40°C operating temperature which is suitable for the following heat sink dimension.

ECMA-__ 04 / 06 / 08 : 250mm x 250mm x 6mm

ECMA-__ 10 : 300mm x 300mm x 12mm

ECMA-__ 13 : 400mm x 400mm x 20mm

ECMA-__ 18 : 550mm x 550mm x 30mm

Material: Aluminum – F40, F60, F80, F100, F130, F180

*2 The built-in brake of the servo motor is for remaining the item in stop status. Do not use it to decelerate or as the dynamic brake.

Medium / High inertia series

ECMA	F113	F△13	F113		F△18
	05	08	13	18	30
Rated power (kW)	0.5	0.85	1.3	1.8	3.0
Rated torque (N-m)*1	3.18	5.41	8.34	11.48	19.10
Max. torque (N-m)	8.92	13.8	23.3	28.7	57.29
Rated speed (r/min)	1500				
Max. speed (r/min)	3000				
Rated current (A)	3.9	7.1	12.6	13	19.4
Max. instantaneous current (A)	12.1	19.4	38.6	36	58.2
Max. power per second (kW/s)	9.8	21.52	34.78	52.93	66.4
Rotor inertia (× 10 ⁻⁴ kg.m ²)	10.3	13.6	20	24.9	54.95
Mechanical constant (ms)	2.8	2.43	1.62	1.7	1.28
Torque constant - KT (N-m/A)	0.82	0.76	0.66	0.88	0.98
Voltage constant – KE (mV/(r/min))	29.5	29.2	24.2	32.2	35.0
Motor resistance (Ohm)	0.624	0.38	0.124	0.185	0.077
Motor inductance (mH)	7	4.77	1.7	2.6	1.27
Electric constant (ms)	11.22	12.55	13.71	14.05	16.5
Insulation class	Class A (UL), Class B (CE)				
Insulation resistance	> 100MΩ, DC 500V				
Insulation strength	1.8k Vac, 1 sec				
Weight – without brake (kg)	6.3	8.6	9.4	10.5	18.5
Weight – with brake (kg)	--	10.0	--	--	22.5
Radial max. loading (N)	490	490	490	490	1470
Axial max. loading (N)	98	98	98	98	490
Max. power per second (kW/s) (with brake)	8.8	19.78	32.66	50.3	63.9

Rotor inertia ($\times 10^{-4}\text{kg.m}^2$) (with brake)	11.5	14.8	21.3	26.2	57.06
Mechanical constant (ms) (with brake)	3.12	2.65	1.73	1.79	1.33
Brake holding torque [Nt-m (min)] ^{*2}	10	10.0	10.0	10.0	25.0
Brake power consumption (at 20°C)[W]	19	19.0	19.0	19.0	20.4
Brake release time [ms (Max)]	10	10	10	10	10
Brake pull-in time [ms (Max)]	70	70	70	70	70
Vibration grade (μm)	15				
Operating temperature (°C)	0 °C~ 40°C				
Storage temperature (°C)	-10°C ~ 80°C				
Operating humidity	20 ~ 90%RH (non-condensing)				
Storage humidity	20 ~ 90%RH (non-condensing)				
Vibration capacity	2.5G				
IP Rating	IP65 (use the waterproof connector and shaft seal installation (or oil seal) model)				
Approvals ^{*4}					

Note:

*1 The rated torque is the continuous permissible torque between 0~40°C operating temperature which is suitable for the following heat sink dimension.

ECMA-__ 04 / 06 / 08 : 250mm x 250mm x 6mm

ECMA-__ 10 : 300mm x 300mm x 12mm

ECMA-__ 13 : 400mm x 400mm x 20mm

ECMA-__ 18 : 550mm x 550mm x 30mm

ECMA-__ 22 : 650mm x 650mm x 35mm

Material: Aluminum – F40, F60, F80, F100, F130, F180, F220

*2 The built-in brake of the servo motor is for remaining the item in stop status. Do not use it to decelerate or as the dynamic brake.

*3 If desire to reach the max. torque limit of motor 250%, it is suggest to use the servo drive with higher watt.

*4 The application of UL safety compliance for ECMA-F11305, ECMA-F11308, ECMA-F11313, ECMA-F11318 is under processing.

11.3 Specifications of Servo Motor (ECML series)

ECML	S16		S20		
	06	08	03	04	05
Rated force (N)	21.8	36	29.6	39.4	49.3
Max. force (N)	87.2	144	118.3	157.5	197.1
Rated current (A _{rms})	0.66	0.66	1.1	1.1	1.1
Max. instantaneous current (A _{rms})	2.64	2.64	4.4	4.4	4.4
Force constant-FC (N/A _{rms})	33	44	26.9	35.8	44.8
Voltage constant –KE (V _{rms} /(m/s))	11	14.7	8.9	11.9	14.9
Armature resistance (Ohm)	55.7	74.2	20	26.6	33.3
Armature inductance (mH)	10.5	14	7	9	11
Rated power (W)	47	62.6	46.9	62.3	78
Max. instantaneous power (W)	751.7	1001.3	749.7	997.1	1248.3
Motor constant (N/√W)	3.2	4.6	4.3	5	5.6
Electric constant (ms)	0.19	0.19	0.35	0.34	0.33
Thermal resistance (°C/W)	1.6	1.2	1.6	1.2	0.96
Weight of coil assembly (kg)	0.35	0.45	0.65	0.83	1.0
Length of coil assembly (mm)	108	138	108	138	168
Vertical attraction Force (N)	0	0	0	0	0
Magnetic pole pitch (mm)	30		60		
Air gap (mm)	0.75				
Max. temperature of coil assembly	130°C				
Insulation class	Class B (CE)				
Insulation resistance	> 10MΩ, DC 500V				
Insulation strength	1.8k Vac,1 sec				
Operating temperature (°C)	0 ~ 40				
Storage temperature (°C)	-10 ~ 80				
Operating humidity	20 ~ 80%RH (non-condensing)				
Storage humidity	20 ~ 80%RH (non-condensing)				
Approvals					

ECML	S25			S32		
	04	06	08	04	06	08
Rated force (N)*1	62.3	93.5	130.0	87.4	138.9	185.2
Max. force (N)	249.2	374	520.0	349.6	555.7	740.9
Rated current (A _{rms})	1.7	1.7	2.5	1.9	2.7	2.7
Max. instantaneous current (A _{rms})	6.8	6.8	10.0	7.6	10.8	10.8
Force constant –FC (N/A _{rms})	36.6	55	52.5	46	51.4	68.6
Back EMF constant – KE (V _{rms} /(m/s))	12.2	18.3	17.5	15.3	17.2	22.9
Armature resistance (Ohm)	11.6	17.4	12.6	14	10.7	14.3
Armature inductance (mH)	14.6	22	23	16	12.5	16.6
Rated power (W)	64.9	97.4	152.5	97.9	151	201.8
Max. instantaneous power (W)	1038.6	1557.8	2439.6	1565.7	2416.5	3229.5
Motor constant (N/√W)	7.7	9.5	10.5	8.8	11.3	13
Electric constant (ms)	1.26	1.26	1.83	1.14	1.17	1.16
Thermal resistance (°C/W)	1.16	0.77	0.49	0.77	0.5	0.37
Weight of coil assembly (kg)	1.1	1.6	2.1	1.5	2.2	2.8
Length of coil assembly (mm)	138	198	258	138	198	258
Vertical attraction Force (N)	0	0	0	0	0	0
Magnetic pole pitch (mm)	60			60		
Air gap (mm)	1.0			1.75		
Max. temperature of coil assembly	130°C					
Insulation class	Class B (CE)					
Insulation resistance	> 10MΩ, DC 500V					
Insulation strength	AC 1500V, 60 seconds					
Operating temperature (°C)	0 ~ 40					
Storage temperature (°C)	-10 ~ 80					
Operating humidity	20 ~ 80%RH (non-condensing)					
Storage humidity	20 ~ 80%RH (non-condensing)					
Approvals						

11.4 Torque Features (T-N curve)

220 V Series

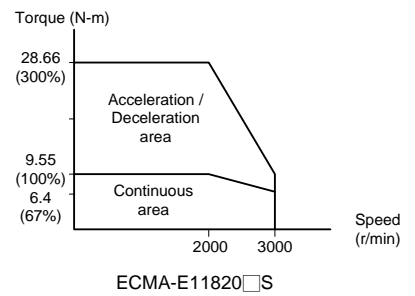
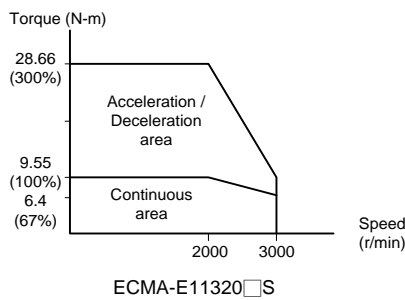
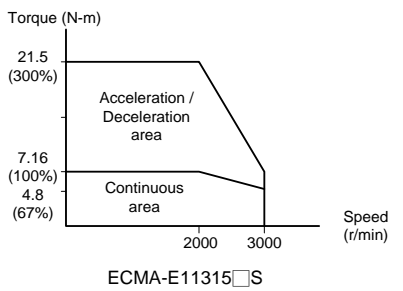
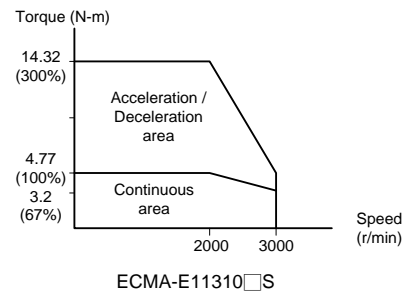
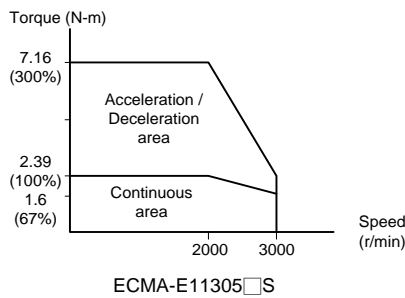
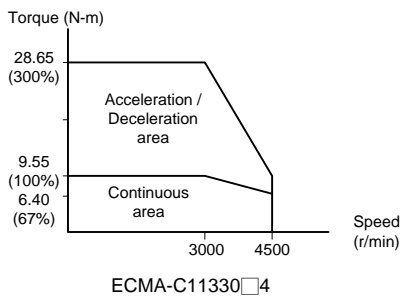
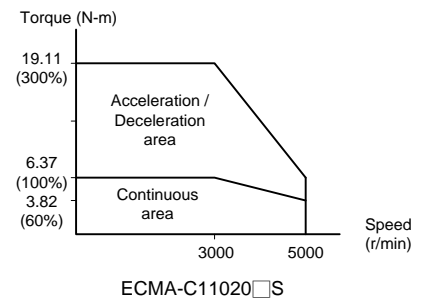
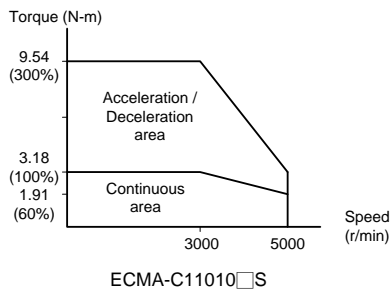
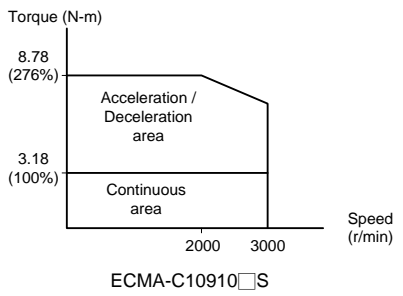
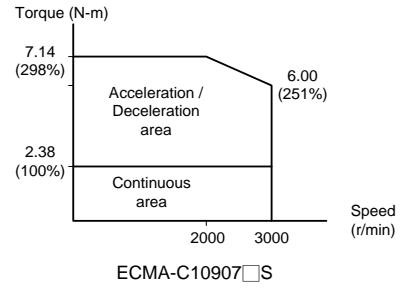
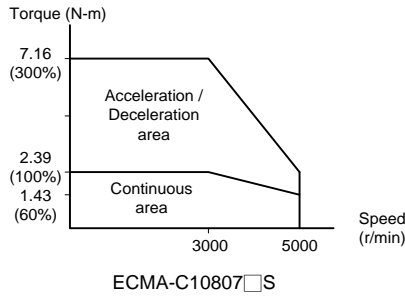
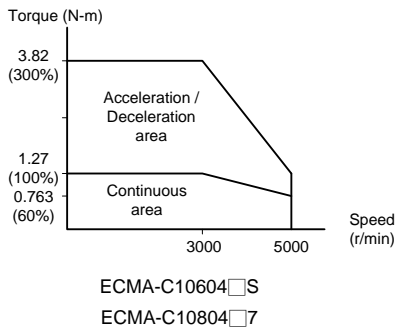
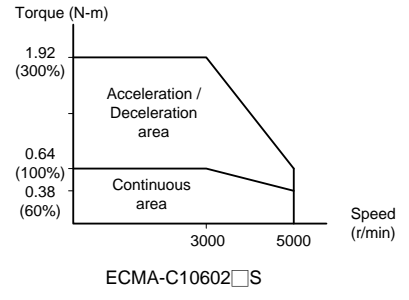
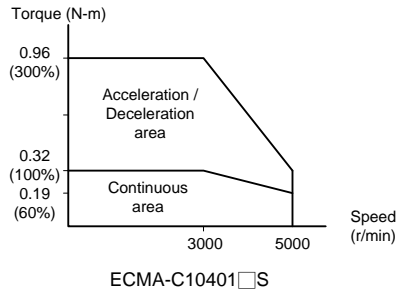
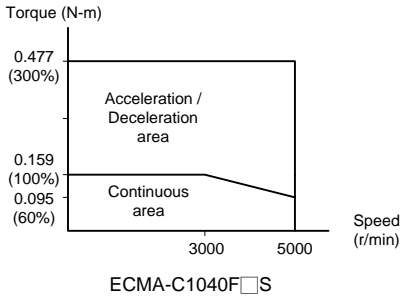

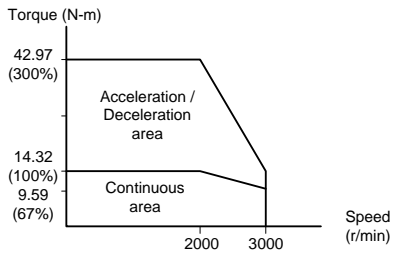

ECMA-E11830 □ S

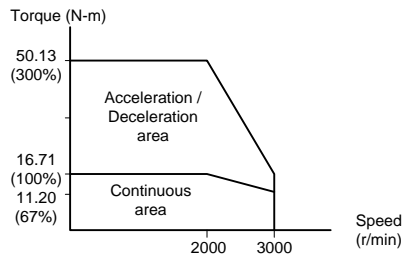

ECMA-E11835 □ S

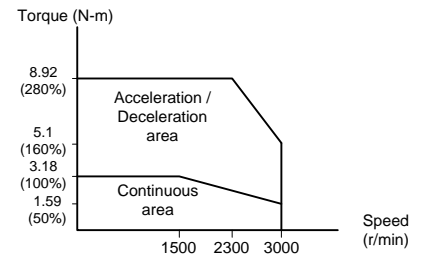

ECMA-F11305 □ S

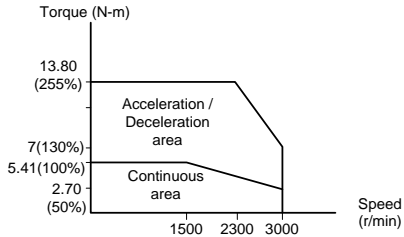

ECMA-F11308 □ S

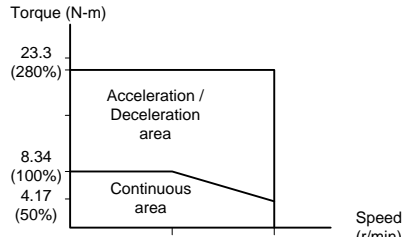

ECMA-F11313 □ S

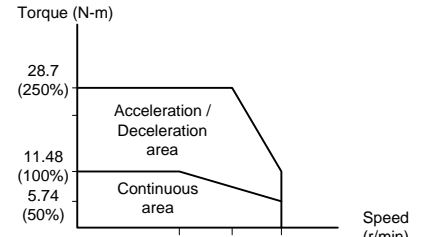

ECMA-F11318 □ S

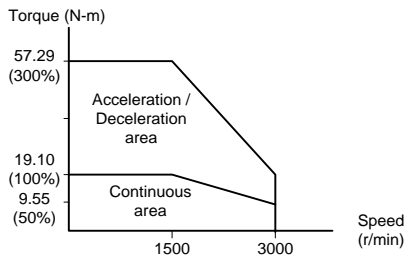

ECMA-F11830 □ S

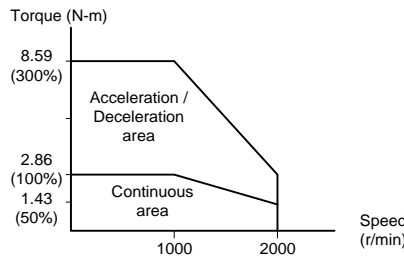

ECMA-G11303 □ S

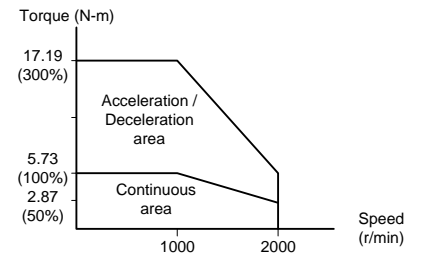

ECMA-G11306 □ S

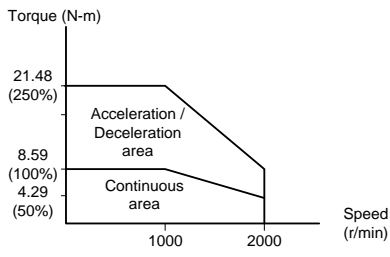

ECMA-G11309 □ S

11.5 Force and Speed Features (F-S curve)

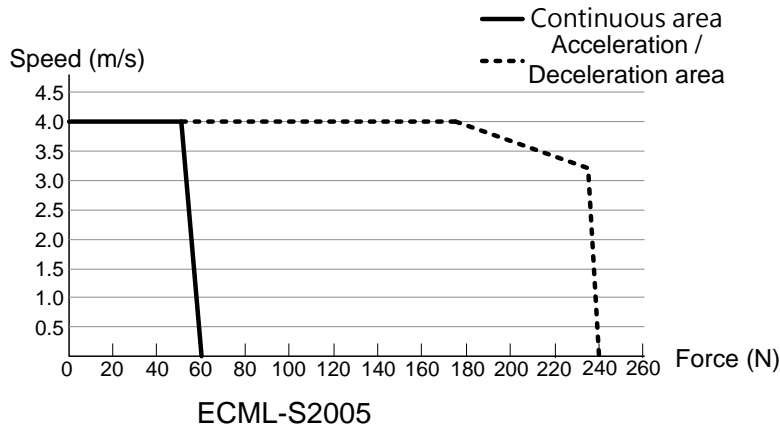
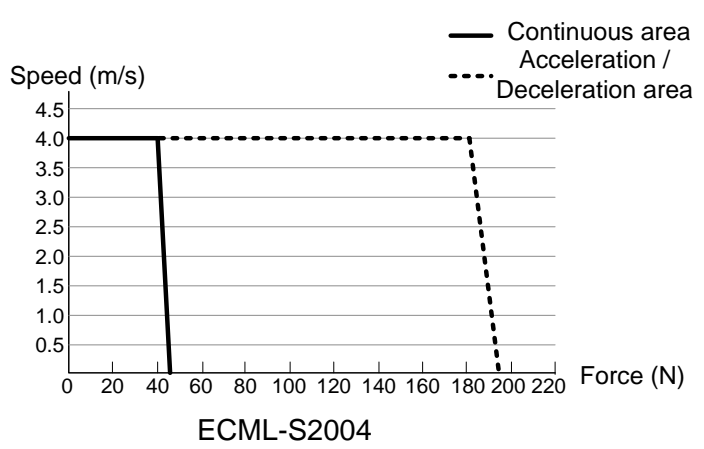
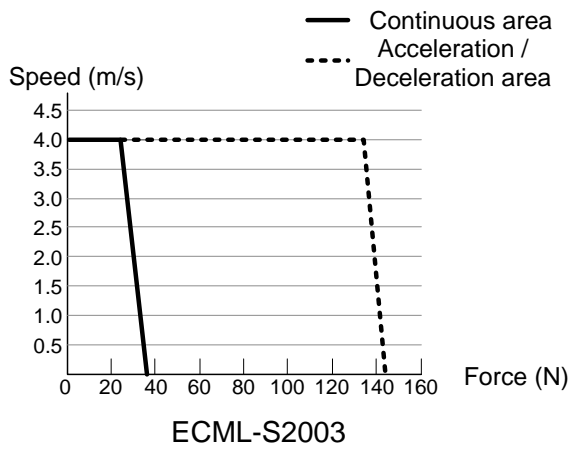
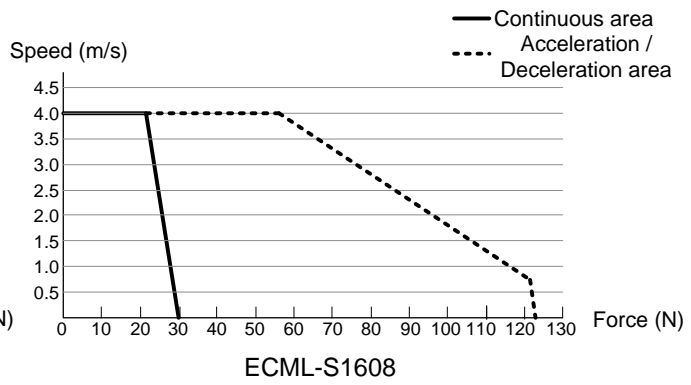
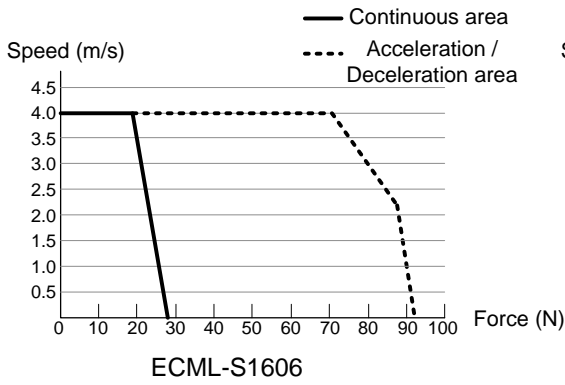

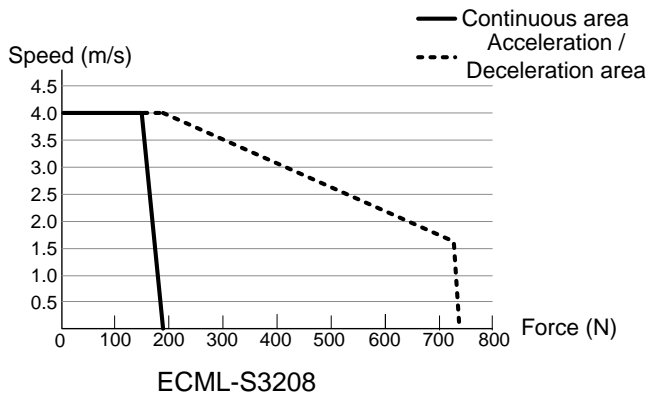
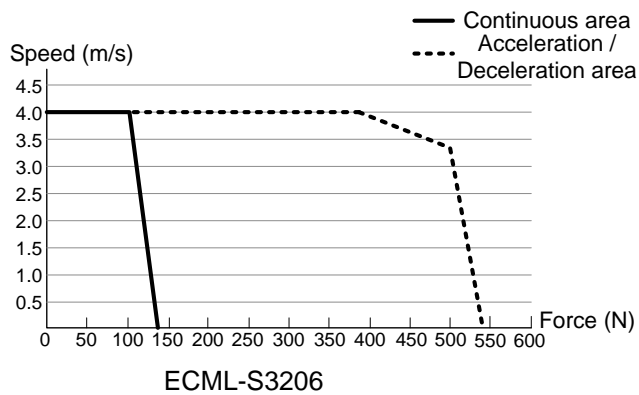
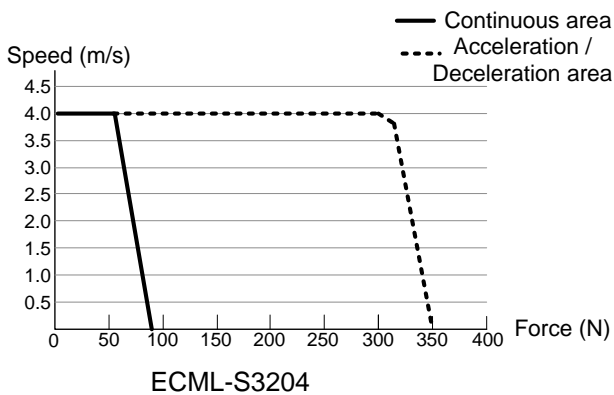
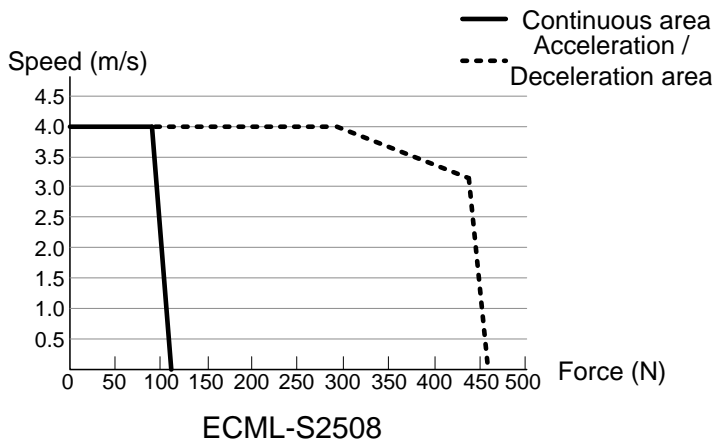
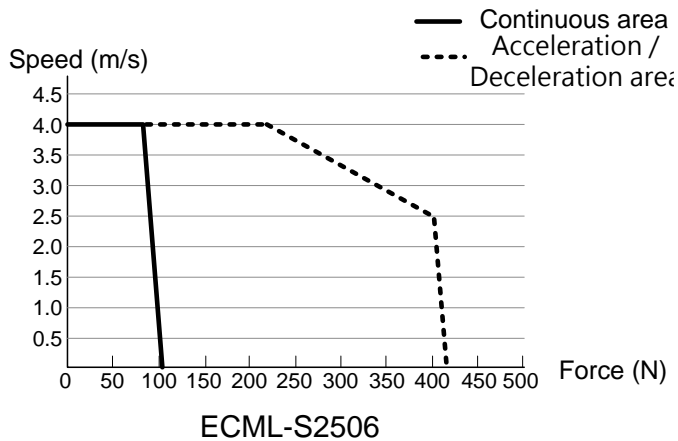
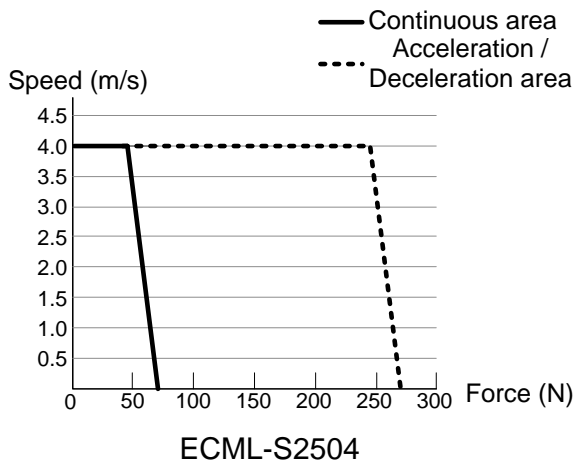

11.6 Overload Features

Definition of overload protection

The overload protection is to prevent the motor in overheat status.

Cause of overload

- 1) When the motor operates over the rated torque, the operation time is too long
- 2) The inertia ratio is set too big and frequently accelerate / decelerate
- 3) Connection error between the power cable and encoder wiring
- 4) Servo gain setting error and cause resonance of the motor
- 5) The motor with brake operates without releasing the brake

The graph of load and operating time

Low inertia (ECMA C1, J1 series)

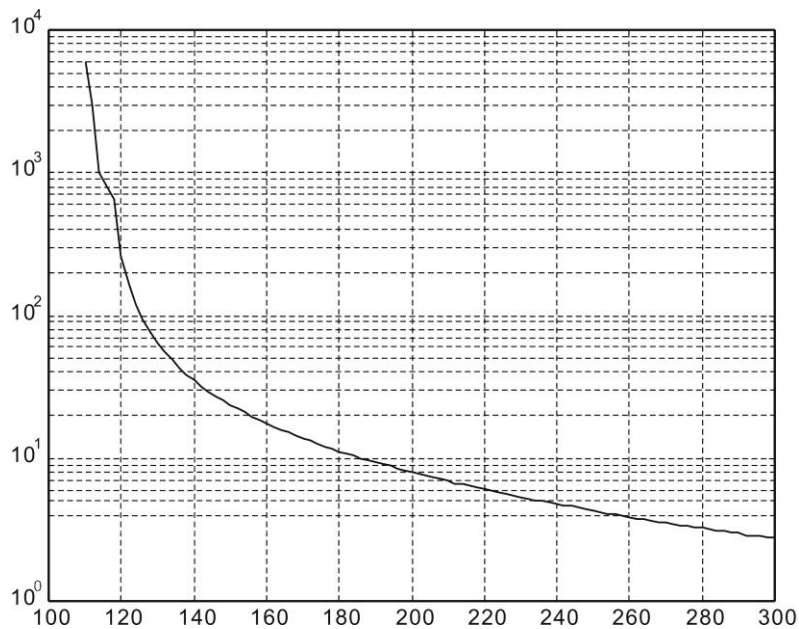

Load	Operating Time
120%	263.8s
140%	35.2s
160%	17.6s
180%	11.2s
200%	8s
220%	6.1s
240%	4.8s
260%	3.9s
280%	3.3s
300%	2.8s

Medium and Medium-high inertia (ECMA E1, F1 series)

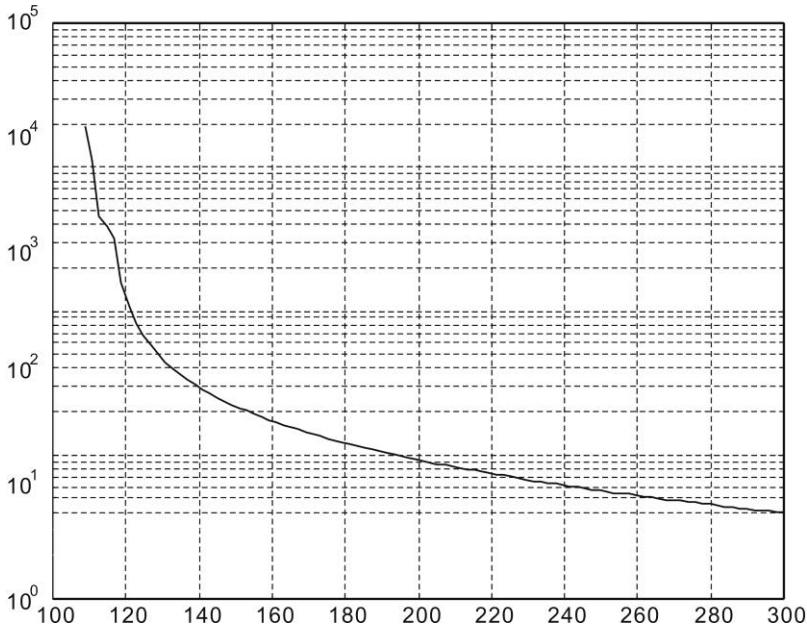

Load	Operating Time
120%	527.6s
140%	70.4s
160%	35.2s
180%	22.4s
200%	16s
220%	12.2s
240%	9.6s
260%	7.8s
280%	6.6s
300%	5.6s

High inertia (ECMA G1 series)

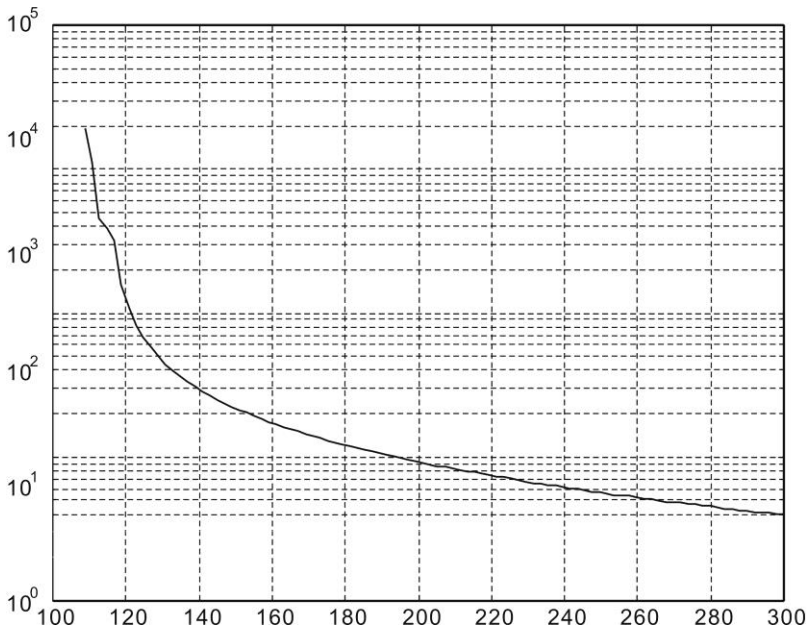

Load	Operating Time
120%	527.6s
140%	70.4s
160%	35.2s
180%	22.4s
200%	16s
220%	12.2s
240%	9.6s
260%	7.8s
280%	6.6s
300%	5.6s

11.7 Dimensions of the Servo Drive

ASD-A2R-0121; ASD-A2R-0221; ASD-A2R-0421 (100W ~ 400W)

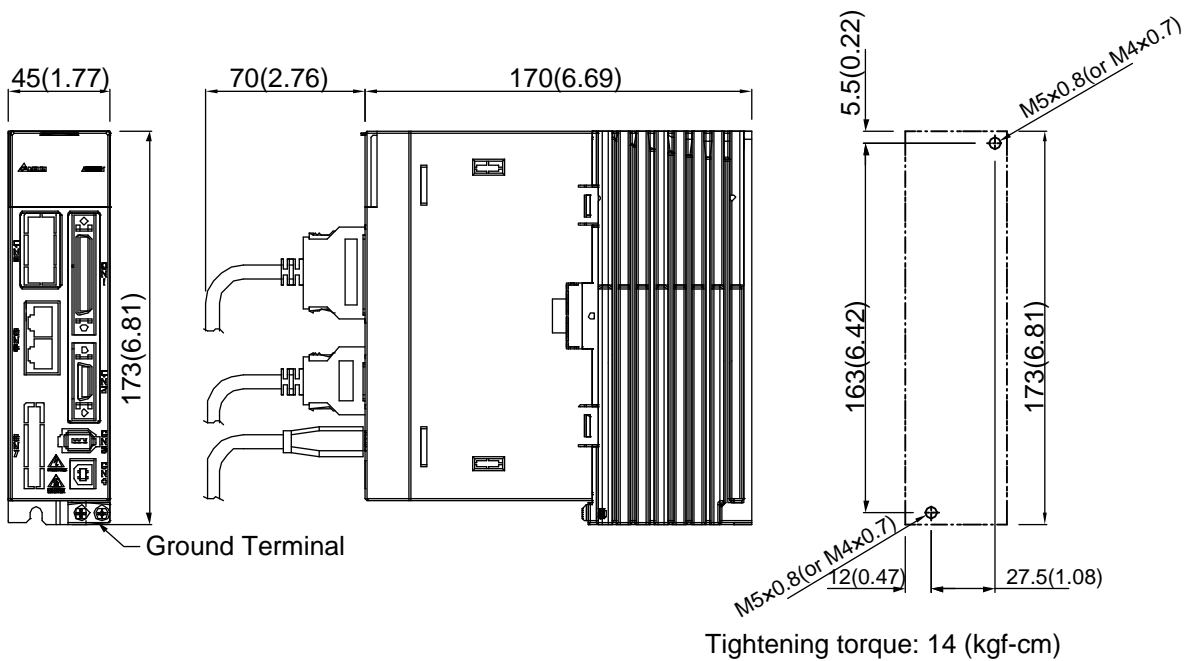

Weight	1.5 (3.3)
--------	-------------

Note:

- 1) Dimensions are in millimeters (inches); Weights are in kilograms (pounds).
- 2) Dimensions and weights might be revised without prior notice.

ASD-A2R-0721; ASD-A2R-1021; ASD-A2R-1521 (750W ~ 1.5kW)

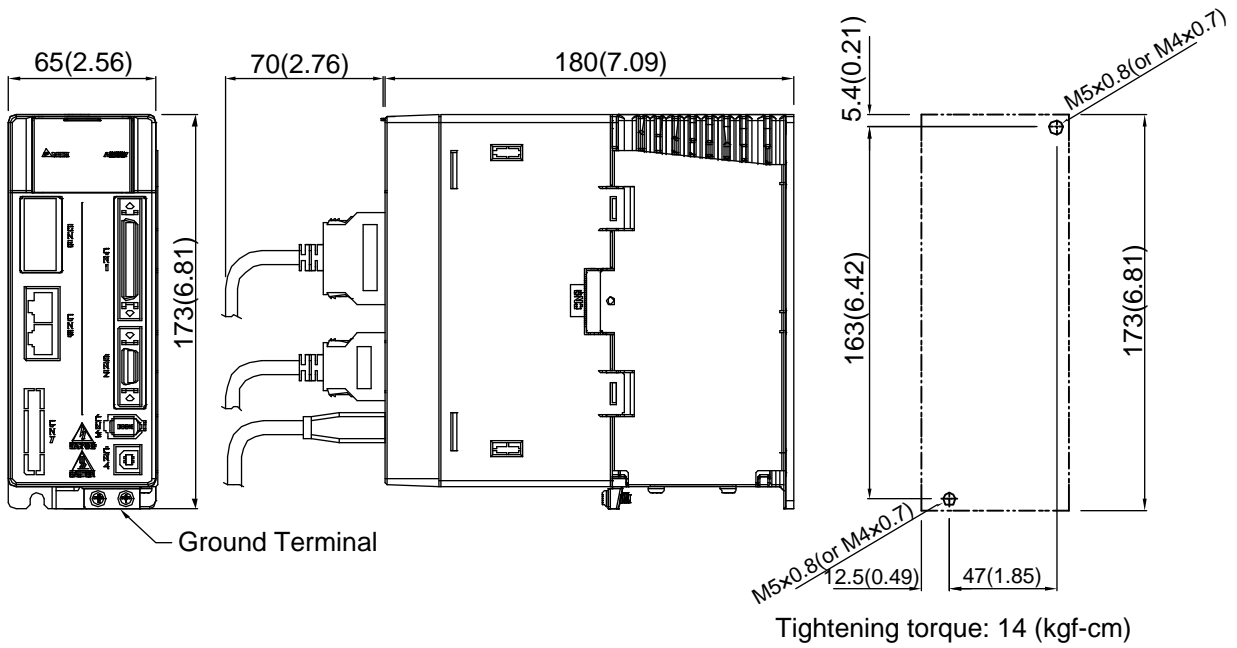

Weight	2.0 (4.4)
--------	-------------

Note:

- 1) Dimensions are in millimeters (inches); Weights are in kilograms (pounds).
- 2) Dimensions and weights might be revised without prior notice.

ASD-A2R-2023; ASD-A2R-3023 (2kW ~ 3kW)

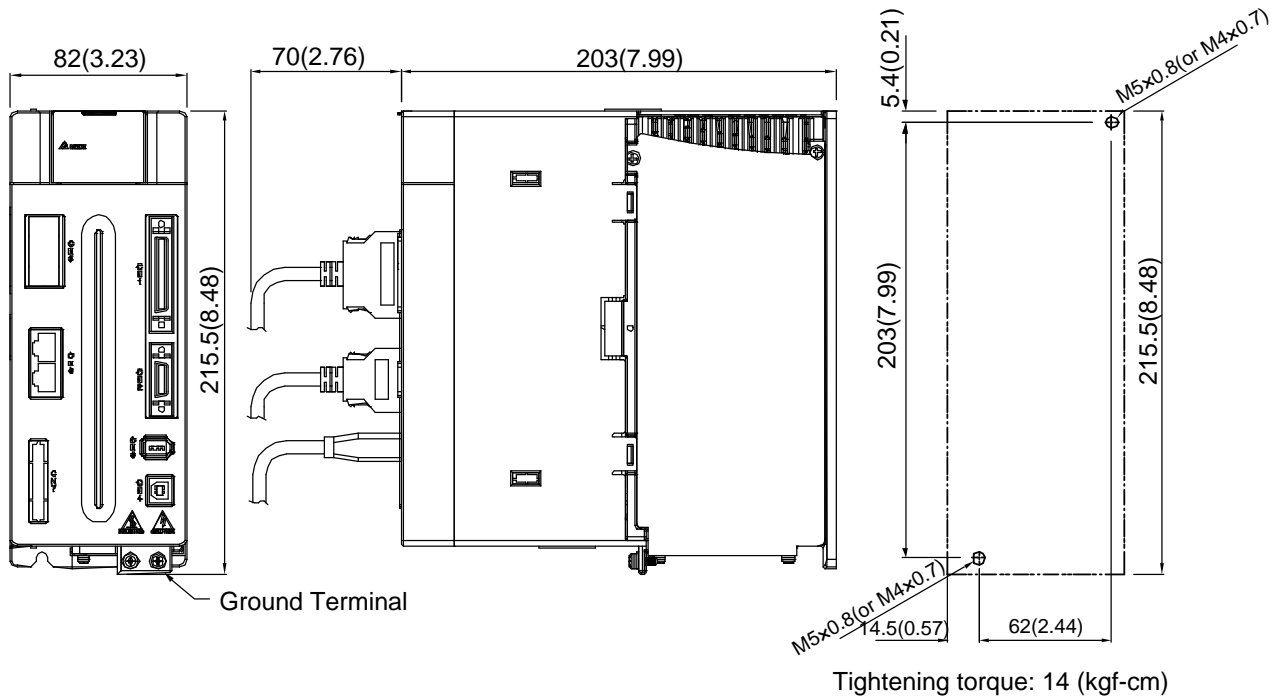

Weight	2.89 (6.36)
--------	---------------

Note:

- 1) Dimensions are in millimeters (inches); Weights are in kilograms (pounds).
- 2) Dimensions and weights might be revised without prior notice.

11.8 Dimensions of ECMA Series Servo Motor

Motor Frame Size: 86 or below (Units: mm)

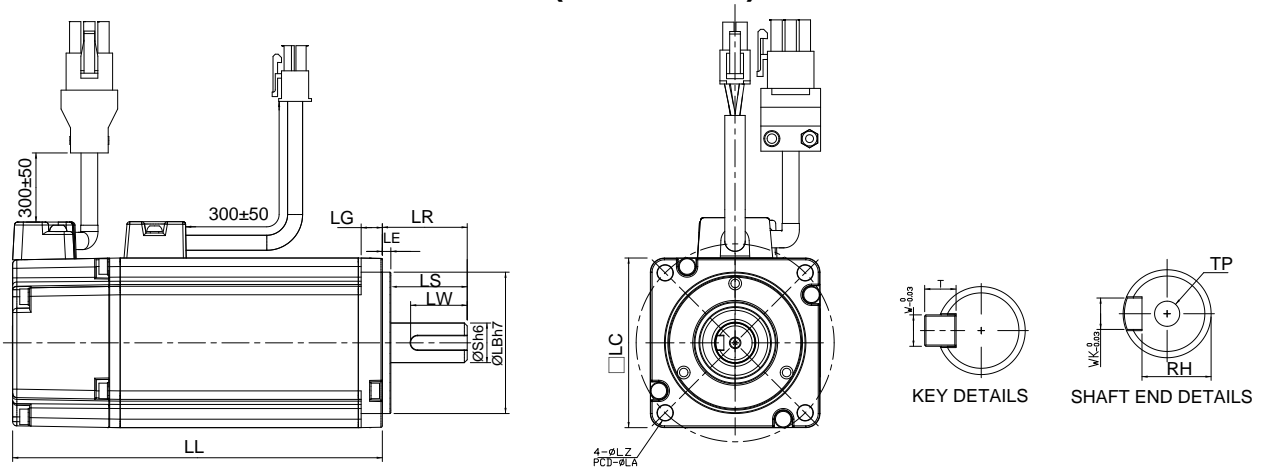

Model	C1040F□S	C△0401□S	C△0602□S	C△0604□S	C△0604□H
LC	40	40	60	60	60
LZ	4.5	4.5	5.5	5.5	5.5
LA	46	46	70	70	70
S	8 ^(+0/-0.009)	8 ^(+0/-0.009)	14 ^(+0/-0.011)	14 ^(+0/-0.011)	14 ^(+0/-0.011)
LB	30 ^(+0/-0.021)	30 ^(+0/-0.021)	50 ^(+0/-0.025)	50 ^(+0/-0.025)	50 ^(+0/-0.025)
LL (without brake)	79.1	100.6	105.5	130.7	145.8
LL (with brake)	--	136.6	141.6	166.8	176.37
LS	20	20	27	27	27
LR	25	25	30	30	30
LE	2.5	2.5	3	3	3
LG	5	5	7.5	7.5	7.5
LW	16	16	20	20	20
RH	6.2	6.2	11	11	11
WK	3	3	5	5	5
W	3	3	5	5	5
T	3	3	5	5	5
TP	--	M3 Depth 8	M4 Depth 15	M4 Depth 15	M4 Depth 15

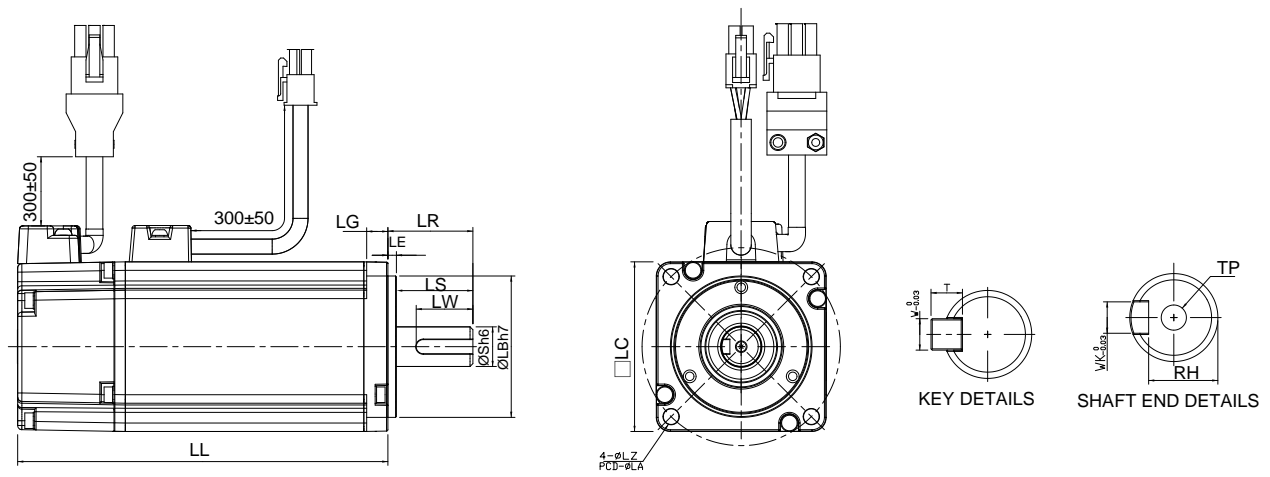

Note:

- 1) Dimensions are in millimeters.
- 2) Dimensions and weights might be revised without prior notice.
- 3) Box, (□) represents the shaft end/ brake or the number of oil seal.
- 4) The boxes (△) in the model names are for encoder resolution types (△=1: Incremental encoder, 20-bit; △=2: Incremental encoder, 17-bit).

Motor Frame Size: 86 or below (Units: mm)

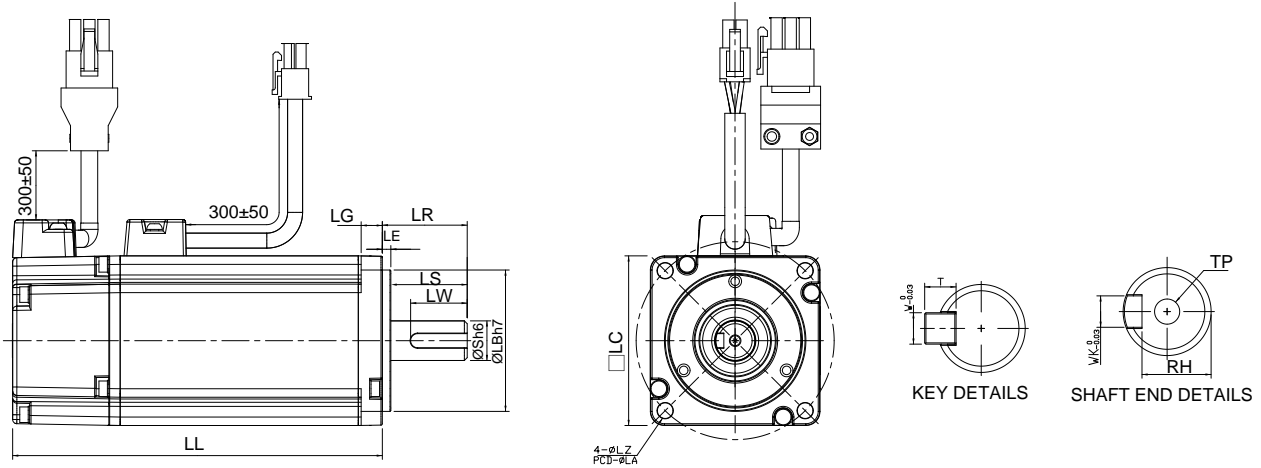

Model	C△0804□7	C△0807□S	C△0807□H	C△0907□S	C△0910□S
LC	80	80	80	86	86
LZ	6.6	6.6	6.6	6.6	6.6
LA	90	90	90	100	100
S	14 ^(+0/-0.011)	19 ^(+0/-0.013)	19 ^(+0/-0.013)	16 ^(+0/-0.011)	16 ^(+0/-0.011)
LB	70 ^(+0/-0.030)	70 ^(+0/-0.030)	70 ^(+0/-0.030)	80 ^(+0/-0.030)	80 ^(+0/-0.030)
LL (without brake)	112.3	138.3	151.1	130.2	153.2
LL (with brake)	152.8	178	189	161.3	184.3
LS	27	32	32	30	30
LR	30	35	35	35	35
LE	3	3	3	3	3
LG	8	8	8	8	8
LW	20	25	25	20	20
RH	11	15.5	15.5	13	13
WK	5	6	6	5	5
W	5	6	6	5	5
T	5	6	6	5	5
TP	M4 Depth 15	M6 Depth 20	M6 Depth 20	M5 Depth 15	M5 Depth 15

Note:

- 1) Dimensions are in millimeters.
- 2) Dimensions and weights might be revised without prior notice.
- 3) Box, (□) represents the shaft end/ brake or the number of oil seal.
- 4) The boxes (△) in the model names are for encoder resolution types (△=1: Incremental encoder, 20-bit; △=2: Incremental encoder, 17-bit).

Motor Frame Size: 100 ~ 130 (Units: mm)

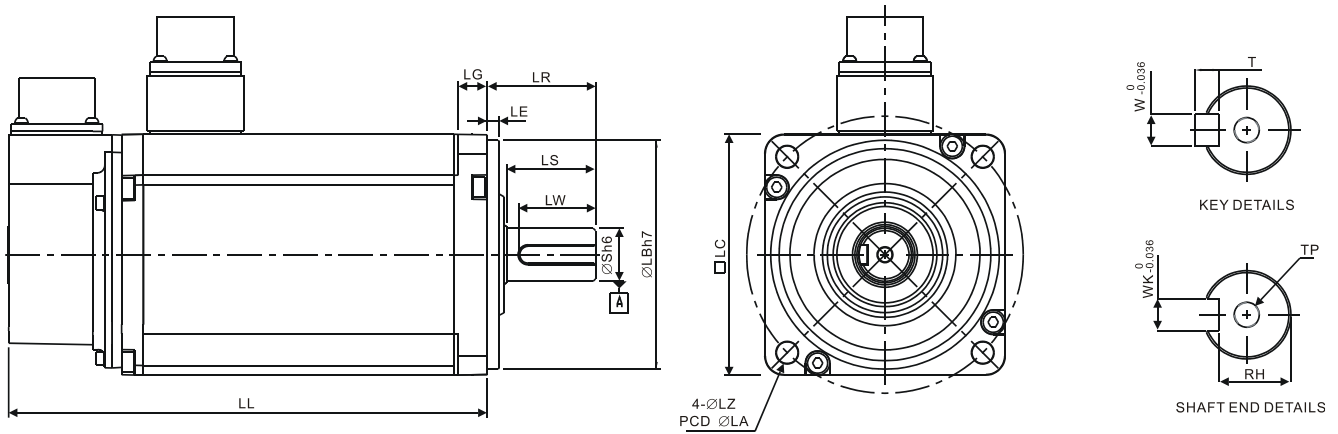

Model	C△1010□S	C△1020□S	C△1330□4	E△1305□S	E△1310□S	E△1315□S	E△1320□S
LC	100	100	130	130	130	130	130
LZ	9	9	9	9	9	9	9
LA	115	115	145	145	145	145	145
S	22 ⁽⁺⁰⁾ _(-0.013)	22 ⁽⁺⁰⁾ _(-0.013)	24 ⁽⁺⁰⁾ _(-0.013)	22 ⁽⁺⁰⁾ _(-0.013)	22 ⁽⁺⁰⁾ _(-0.013)	22 ⁽⁺⁰⁾ _(-0.013)	22 ⁽⁺⁰⁾ _(-0.013)
LB	95 ⁽⁺⁰⁾ _(-0.035)	95 ⁽⁺⁰⁾ _(-0.035)	110 ⁽⁺⁰⁾ _(-0.035)	110 ⁽⁺⁰⁾ _(-0.035)	110 ⁽⁺⁰⁾ _(-0.035)	110 ⁽⁺⁰⁾ _(-0.035)	110 ⁽⁺⁰⁾ _(-0.035)
LL (without brake)	153.3	199	187.5	147.5	147.5	167.5	187.5
LL (with brake)	192.5	226	216.0	183.5	183.5	202	216
LS	37	37	47	47	47	47	47
LR	45	45	55	55	55	55	55
LE	5	5	6	6	6	6	6
LG	12	12	11.5	11.5	11.5	11.5	11.5
LW	32	32	36	36	36	36	36
RH	18	18	20	18	18	18	18
WK	8	8	8	8	8	8	8
W	8	8	8	8	8	8	8
T	7	7	7	7	7	7	7
TP	M6 Depth 20	M6 Depth 20	M6 Depth 20	M6 Depth 20	M6 Depth 20	M6 Depth 20	M6 Depth 20

Note:

- 1) Dimensions are in millimeters.
- 2) Dimensions and weights might be revised without prior notice.
- 3) Box, (□) represents the shaft end/ brake or the number of oil seal.
- 4) The boxes (△) in the model names are for encoder resolution types (△=1: Incremental encoder, 20-bit; △=2: Incremental encoder, 17-bit).

Motor Frame Size: 100 ~ 130 (Units: mm)

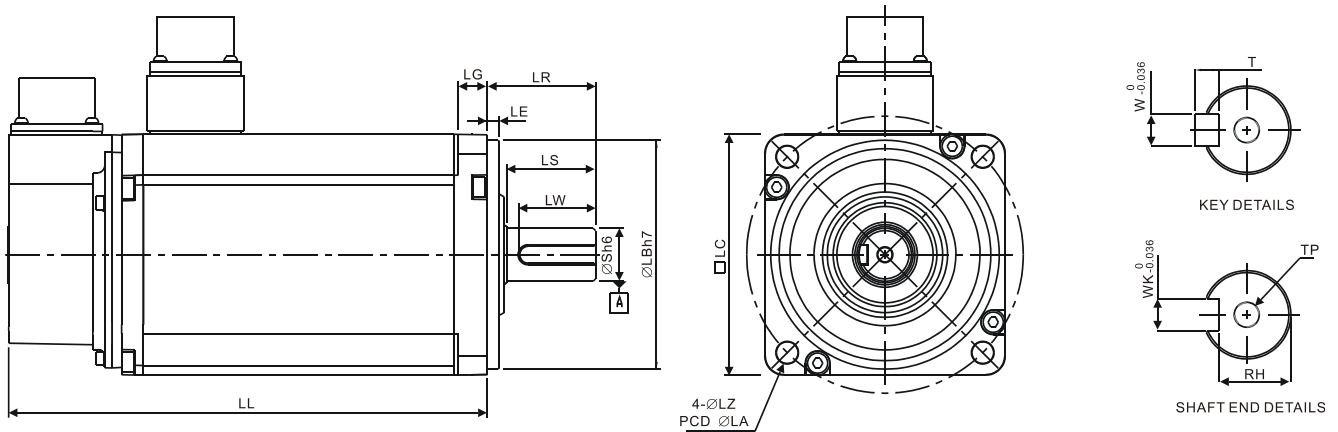

Model	F11305□S	F△1308□S	F11313□S	F11318□S	G△1303□S	G△1306□S	G△1309□S
LC	130	130	130	130	130	130	130
LZ	9	9	9	9	9	9	9
LA	145	145	145	145	145	145	145
S	22 ⁺⁰ _{-0.013}	22 ⁺⁰ _{-0.013}	22 ⁺⁰ _{-0.013}	22 ⁺⁰ _{-0.013}	22 ⁺⁰ _{-0.013}	22 ⁺⁰ _{-0.013}	22 ⁺⁰ _{-0.013}
LB	110 ⁺⁰ _{-0.035}	110 ⁺⁰ _{-0.035}	110 ⁺⁰ _{-0.035}	110 ⁺⁰ _{-0.035}	110 ⁺⁰ _{-0.035}	110 ⁺⁰ _{-0.035}	110 ⁺⁰ _{-0.035}
LL (without brake)	139.5	152.5	187.5	202	147.5	147.5	163.5
LL (with brake)	168	181	--	--	183.5	183.5	198
LS	47	47	47	47	47	47	47
LR	55	55	55	55	55	55	55
LE	6	6	6	6	6	6	6
LG	11.5	11.5	11.5	11.5	11.5	11.5	11.5
LW	36	36	36	36	36	36	36
RH	18	18	18	18	18	18	18
WK	8	8	8	8	8	8	8
W	8	8	8	8	8	8	8
T	7	7	7	7	7	7	7
TP	M6 Depth 20	M6 Depth 20	M6 Depth 20	M6 Depth 20	M6 Depth 20	M6 Depth 20	M6 Depth 20

Note:

- 1) Dimensions are in millimeters.
- 2) Dimensions and weights might be revised without prior notice.
- 3) Box, (□) represents the shaft end/ brake or the number of oil seal.
- 4) The boxes (△) in the model names are for encoder resolution types (△=1: Incremental encoder, 20-bit; △=2: Incremental encoder, 17-bit).

Motor Frame Size: 180 or above (Units: mm)

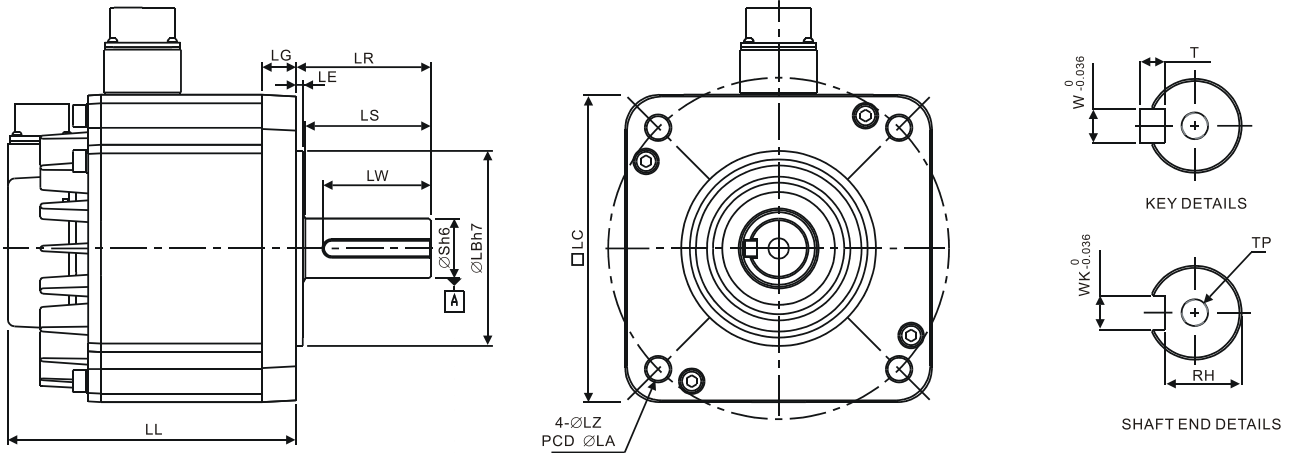

Model	E△1820□S	E△1830□S	E△1835□S	F△1830□S
LC	180	180	180	180
LZ	13.5	13.5	13.5	13.5
LA	200	200	200	200
S	35 ⁽⁺⁰⁾ _(-0.016)	35 ⁽⁺⁰⁾ _(-0.016)	35 ⁽⁺⁰⁾ _(-0.016)	35 ⁽⁺⁰⁾ _(-0.016)
LB	114.3 ⁽⁺⁰⁾ _(-0.035)	114.3 ⁽⁺⁰⁾ _(-0.035)	114.3 ⁽⁺⁰⁾ _(-0.035)	114.3 ⁽⁺⁰⁾ _(-0.035)
LL (without brake)	169	202.1	202.1	202.1
LL (with brake)	203.1	235.3	235.3	235.3
LS	73	73	73	73
LR	79	79	79	79
LE	4	4	4	4
LG	20	20	20	20
LW	63	63	63	63
RH	30	30	30	30
WK	10	10	10	10
W	10	10	10	10
T	8	8	8	8
TP	M12 Depth 25	M12 Depth 25	M12 Depth 25	M12 Depth 25

Note:

- 1) Dimensions are in millimeters.
- 2) Dimensions and weights might be revised without prior notice.
- 3) Box, (□) represents the shaft end/ brake or the number of oil seal.
- 4) The boxes (△) in the model names are for encoder resolution types (△=1: Incremental encoder, 20-bit; △=2: Incremental encoder, 17-bit).

11.9 Dimensions of ECML Series Servo Motor

Coreless (Units: mm)

Coil Assembly

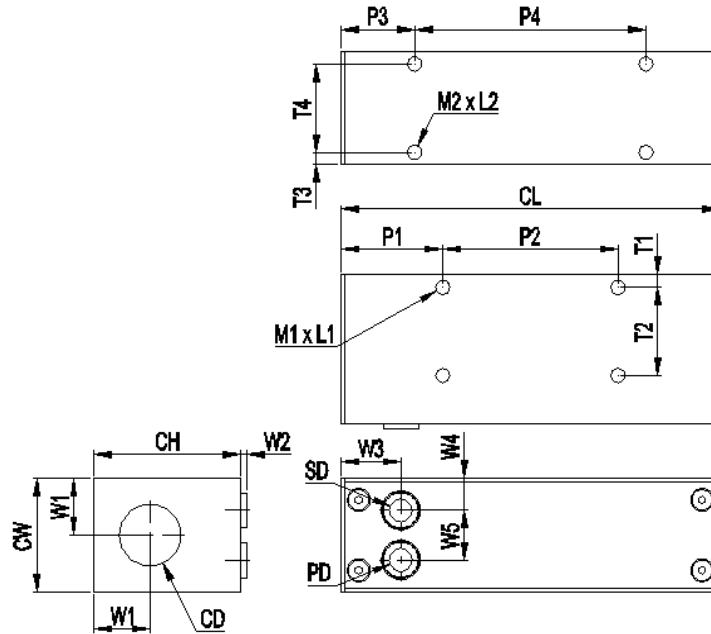

Model	S1606	S1608	S2003	S2004	S2005
CH	42	42	52	52	52
CW	32	32	42	42	42
CD	17.5	17.5	21.5	21.5	21.5
CL	108	138	108	138	168
P1	29	29	29	29	29
P2	50	80	50	80	110
P3	21	21	21	21	21
P4	66	96	66	96	126
T1	3.5	3.5	3.5	3.5	3.5
T2	25	25	35	35	35
T3	3.5	3.5	3.5	3.5	3.5
T4	25	25	35	35	35
M1 x L1	M4x4.5	M4x4.5	M4x7	M4x7	M4x7
M2 x L2	M4x4.5	M4x4.5	M4x7	M4x7	M4x7
W1	16	16	21	21	21
W2	15	15	15	15	15
W3	17	17	17	17	17
W4	9	9	11	11	11
W5	14	14	20	20	20
PD	6	6	6	6	6
SD	6	6	6	6	6

Coil Assembly

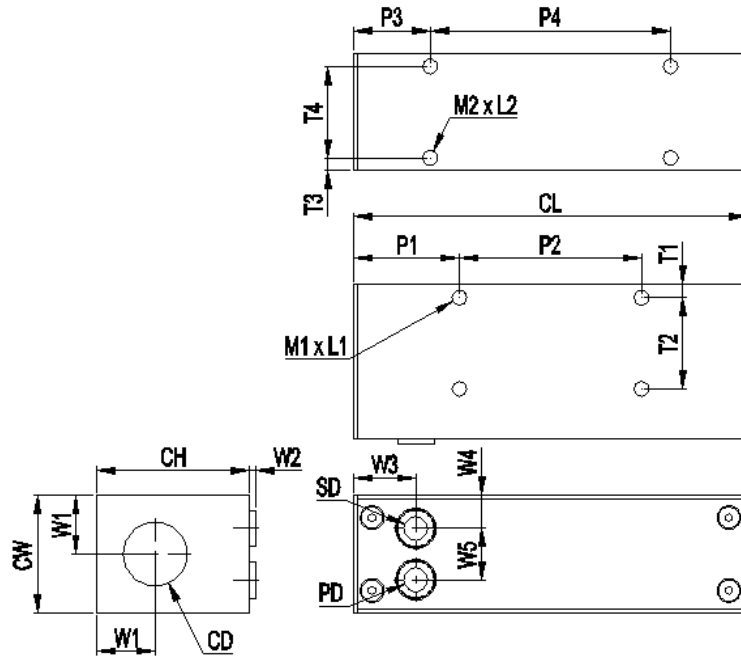

Model	S2504	S2506	S2508	S3204	S3206	S3208
CH	62	62	62	70	70	70
CW	52	52	52	60	60	60
CD	27	27	27	35.5	35.5	35.5
CL	138	198	258	138	198	258
P1	37	37	37	37	37	37
P2	64	124	184	64	124	92x2
P3	27	27	27	27	27	27
P4	84	144	204	84	144	204
T1	5	5	5	5	5	5
T2	42	42	42	50	50	50
T3	5	5	5	5	5	5
T4	42	42	42	50	50	50
M1 x L1	M5x8	M5x8	M5x8	M6x10	M6x10	M6x10
M2 x L2	M5x8	M5x8	M5x8	M6x10	M6x10	M6x10
W1	26	26	26	30	30	30
W2	1.5	1.5	1.5	1.5	1.5	1.5
W3	21	21	21	21	21	21
W4	11	11	11	13	13	13
W5	30	30	30	34	34	34
PD	7	7	7	7	7	7
SD	6	6	6	6	6	6

Magnet Shaft

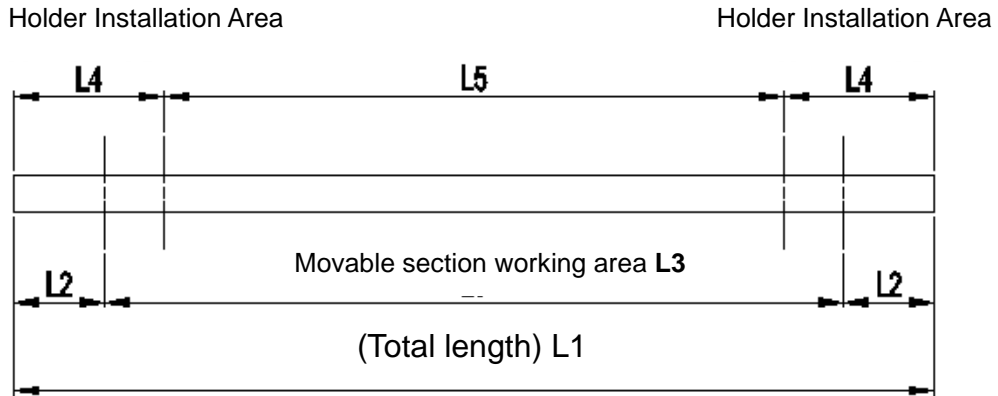

Model	SM16						SM20					
	0340	0520	0700	0880	1060	1240	0370	0550	0730	0910	1090	1270
L1	340	520	700	880	1060	1240	370	550	730	910	1090	1270
L2	35	35	35	35	35	35	35	35	35	35	35	35
L3	270	450	630	810	990	1170	300	480	660	840	1020	1200
L4	25	40	40	60	60	60	35	50	50	60	60	60
L5	290	440	620	760	940	1120	300	450	630	790	970	1150
Approx. mass	0.51	0.78	1.05	1.32	1.59	1.86	0.87	1.29	1.71	2.13	2.55	2.97

Model	SM 25						SM 32					
	0390	0570	0390	0570	0390	0570	0390	0570	0390	0570	0390	0570
L1	390	570	390	570	390	570	390	570	390	570	390	570
L2	45	45	45	45	45	45	45	45	45	45	45	45
L3	300	480	300	480	300	480	300	480	300	480	300	480
L4	45	45	45	45	45	45	45	45	45	45	45	45
L5	300	480	300	480	300	480	300	480	300	480	300	480
Approx. mass	1.43	2.08	1.43	2.08	1.43	2.08	1.43	2.08	1.43	2.08	1.43	2.08

(This page is intentionally left blank.)

Chapter 12 Setting of Motor Parameters

12.1 Tuning Procedure of Motor Parameters

Delta ASDA-A2R Servo Drive provides a more flexible option for selecting servo drive and motor. Once the system is properly set through the tuning procedure, it can go with the permanent magnet synchronous linear motor and permanent magnet synchronous rotary motor of other brands.

Users can setup motor parameters through the software or panel. For safety reasons, please Servo OFF the servo drive beforehand.

The tuning procedures are as follows.

STEP 1: Open PC software. Click the motor system setting from parameter function selection.

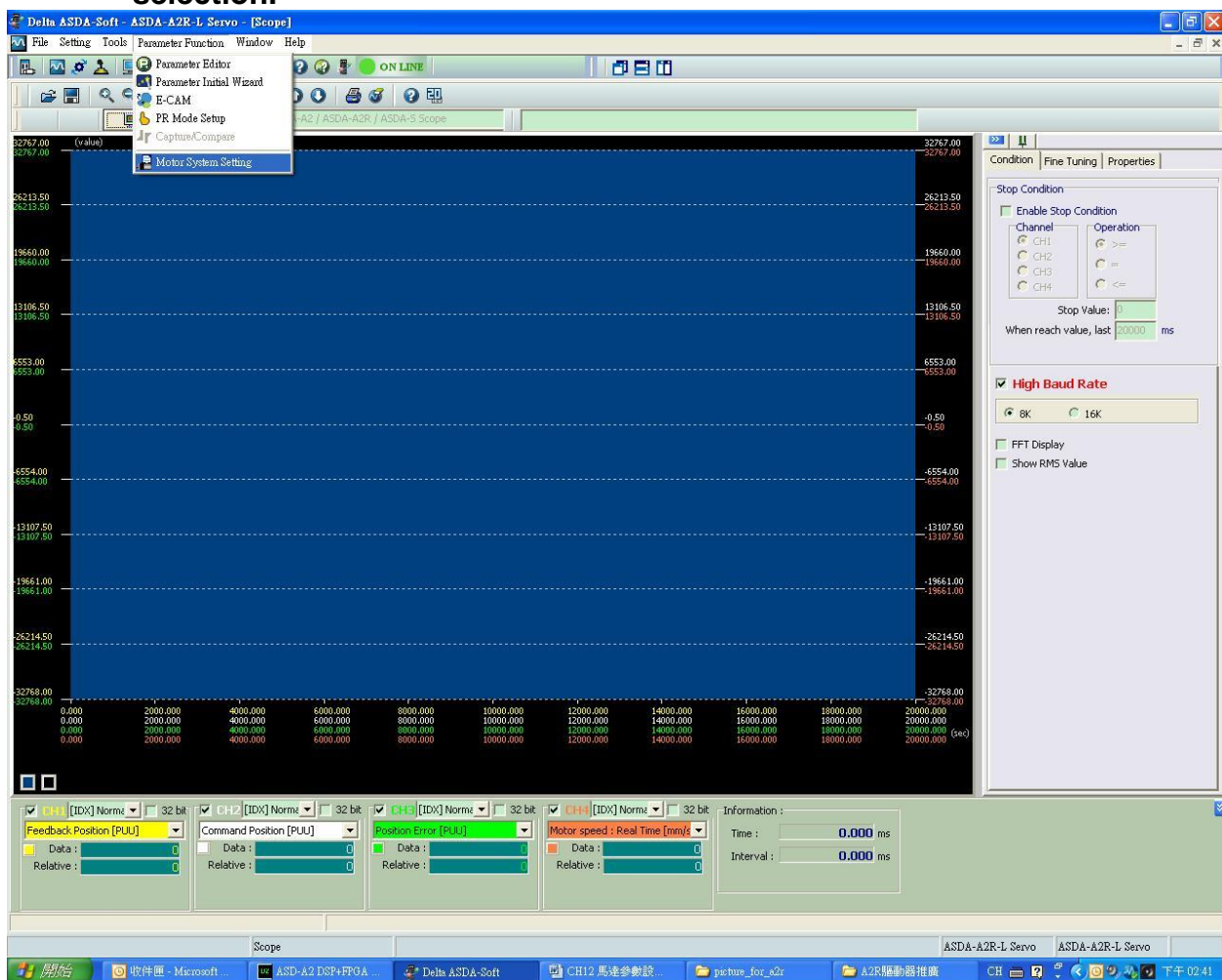

STEP 2: Setup motor parameters

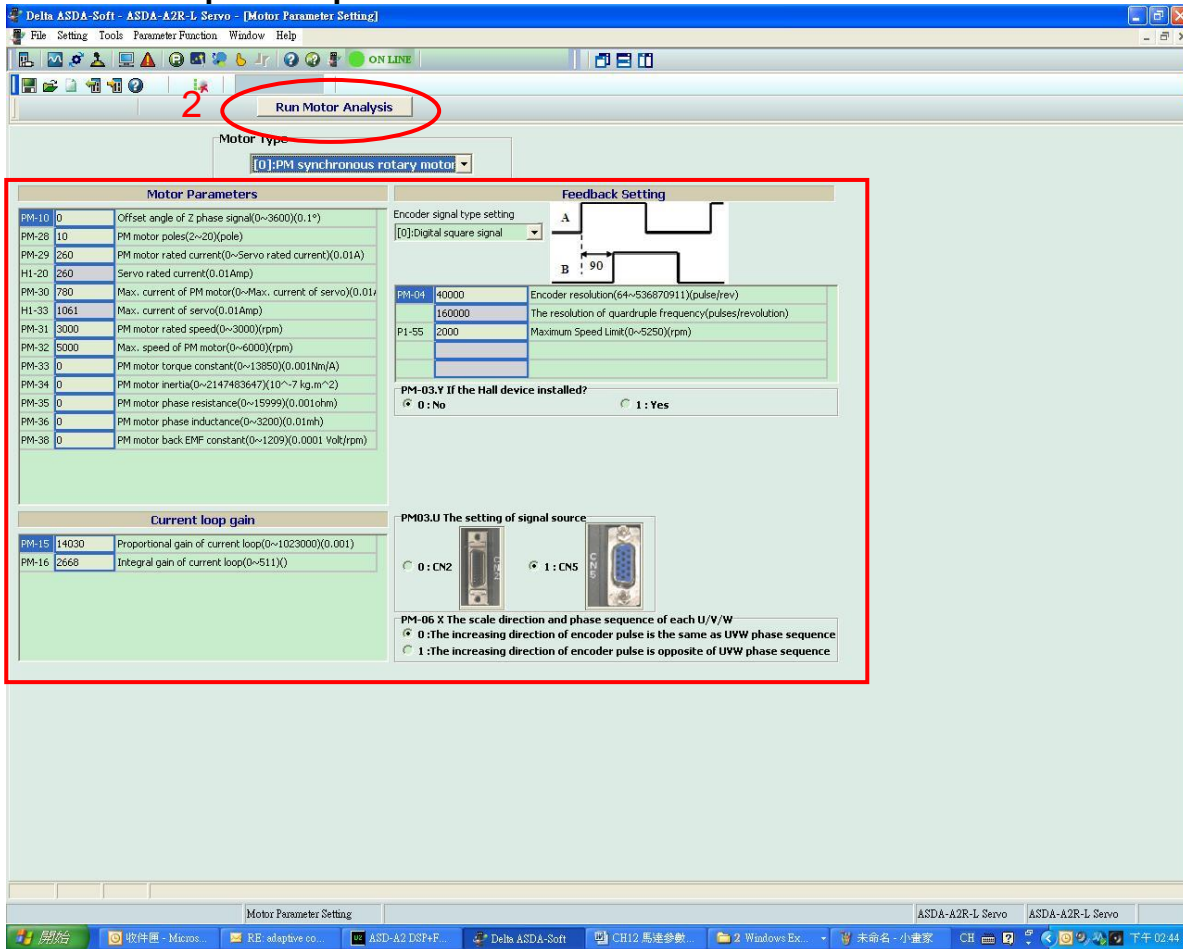

Two methods can setup motor parameters:

1. Directly edit motor parameters:

If users already know all motor parameters, please directly enter the value of each parameter for editing. Please refer to Chapter 8, PM Parameter Groups for relevant motor parameters. After editing, download the parameter to the servo drive and set PM-02 to 1. Then, re-servo ON the servo drive to enable the setting.

2. Run Motor Analysis:

Users can follow the instructions of Motor Analysis to finish the setting of motor parameters. The following steps detail the function of Motor Analysis.

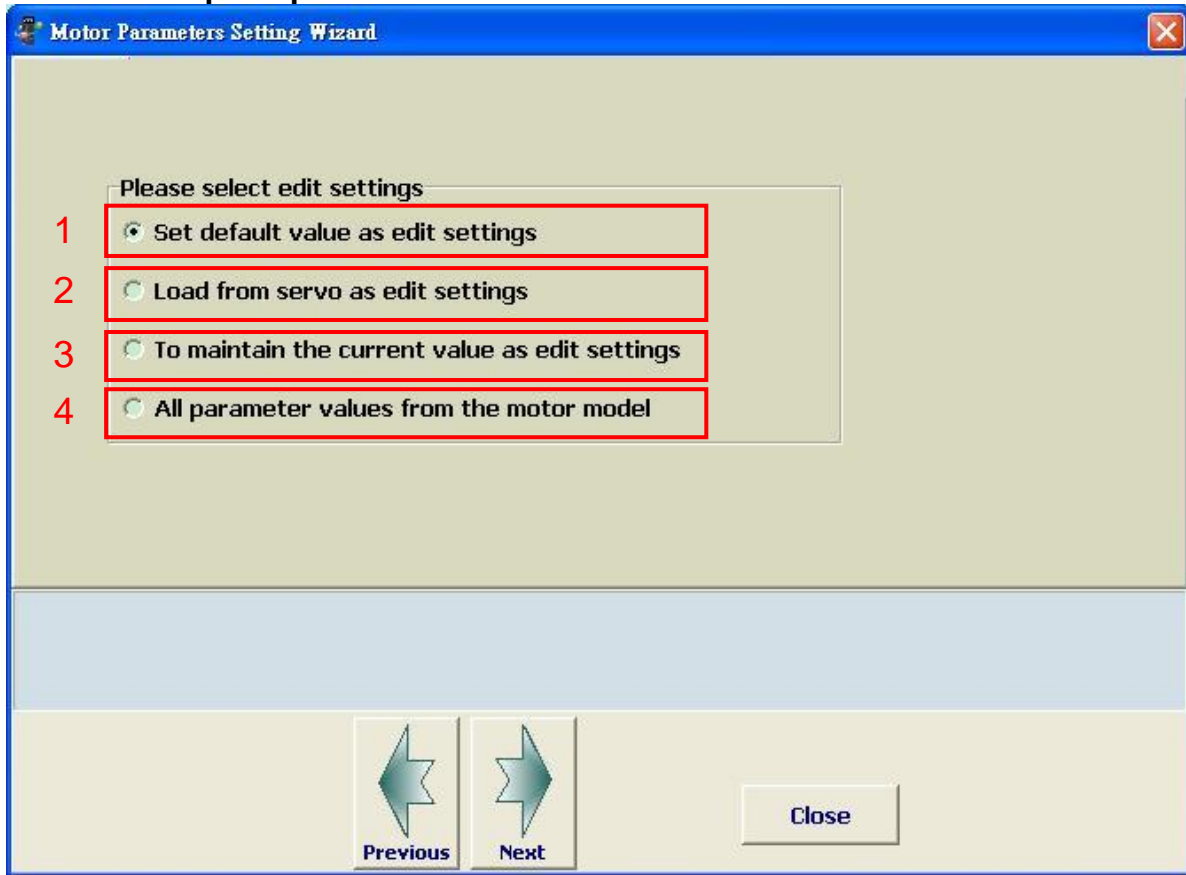
STEP 3: Setup the parameter initial value

This page is for setting up the initial value of parameter editing.

1. Set default value as edit settings: the initial value of parameter editing = The initial value of the parameter
2. Load from servo as edit settings: the initial value of parameter editing = Servo parameter value
3. To maintain the current value as edit settings: the initial value of parameter editing = The parameter value edited in STEP 2.

STEP 4: The setting of motor basic parameters

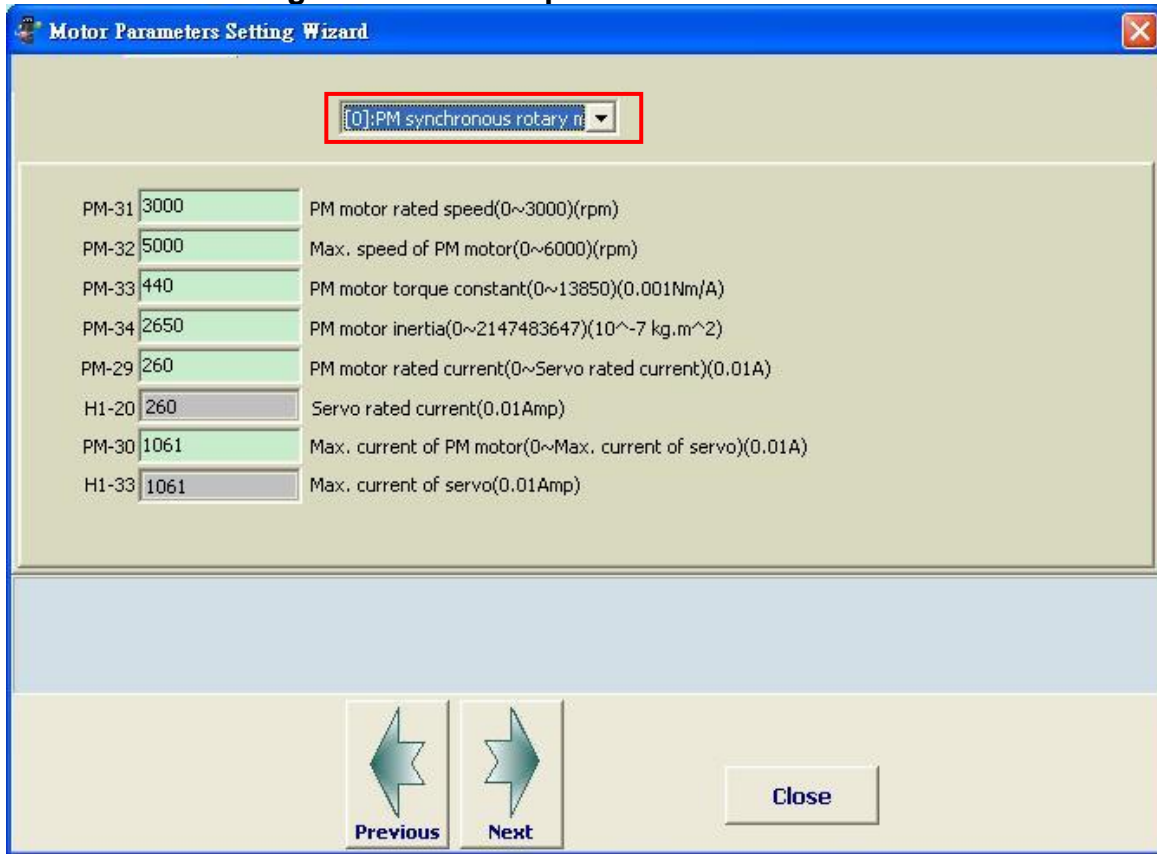

Select the motor type:

Permanent magnet synchronous linear motor or permanent magnet synchronous rotary motor

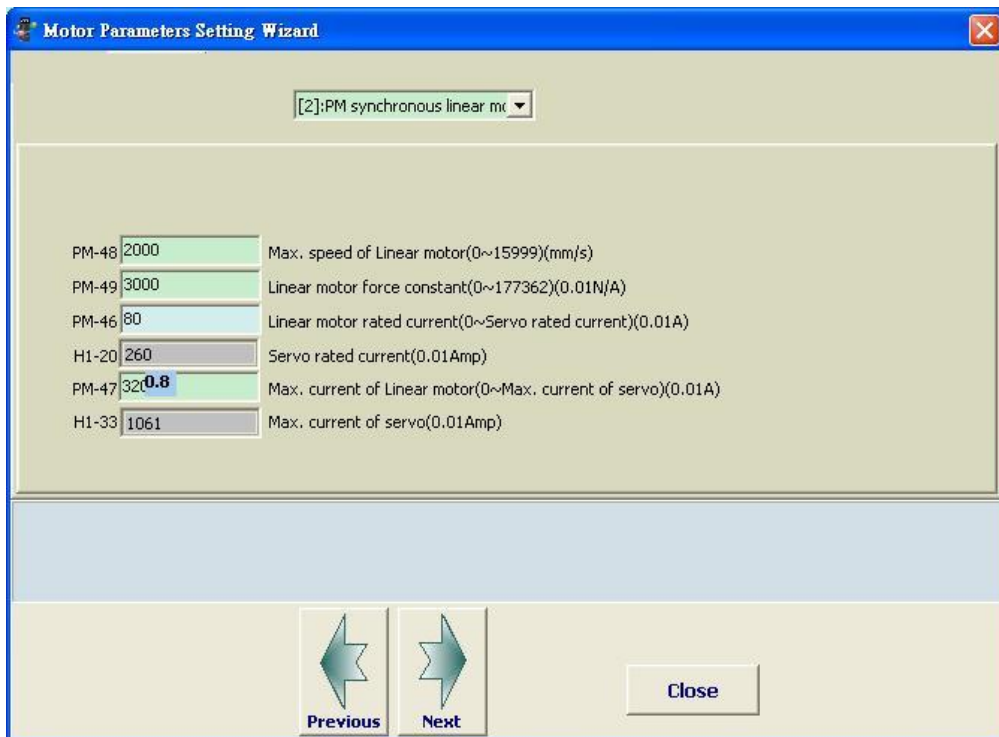

When editing parameters, if the selected parameter has decimal point, the software will show the result after computing.

STEP 4.1: The setting of permanent magnet synchronous rotary motor

No.	Code	Value	Description
1	PM-31	3000	PM motor rated speed(0~3000)(rpm)
2	PM-32	5000	Max. speed of PM motor(0~6000)(rpm)
3	PM-33	440	PM motor torque constant(0~13850)(0.001Nm/A)
4	PM-34	2650	PM motor inertia(0~2147483647)(10 ⁻⁷ kg.m ²)
5	PM-29	260	PM motor rated current(0~Servo rated current)(0.01A)
6	H1-20	260	Servo rated current(0.01Amp)
7	PM-30	1061	Max. current of PM motor(0~Max. current of servo)(0.01A)
8	H1-33	1061	Max. current of servo(0.01Amp)

1. The rated speed of PM synchronous rotary motor: range: 0~3000; unit: rpm
2. The maximum speed of PM synchronous rotary motor: range: 0~6000; unit: rpm
3. The torque constant of PM synchronous rotary motor: range: 0~13850; unit: 0.001Nm/A (ampere)
4. The inertia of PM synchronous rotary motor: unit: $10^{-7} \text{ kg} \cdot \text{m}^2$
5. The rated current of PM synchronous rotary motor: range: 0~the rated current of the servo; unit: 0.01A (ampere); the input value cannot exceed the rated current of the servo.
6. The rated current of the servo: It is the read-only value
7. The maximum current of PM synchronous rotary motor: input the maximum current of the motor; range: 0~the maximum current of the servo; unit: 0.01A (ampere)
8. The maximum current of the servo: It is the read-only value

STEP 4.2: The setting of permanent magnet synchronous linear motor



1. The maximum speed of PM synchronous linear motor: range: 0~15999; unit: $10^{-3}m/s$
2. The force constant of PM synchronous linear motor: range: 0~177362; unit: 0.01N/A (ampere)
3. The rated current of PM synchronous linear motor: range: 0~the rated current of the servo; unit: 0.01A (ampere); the input value cannot exceed the rated current of the servo.
4. The rated current of the servo: It is the read-only value
5. The maximum current of PM synchronous linear motor: input the maximum current of linear motor; range: 0~the maximum current of the servo; unit: 0.01A (ampere)
6. The maximum current of the servo: It is the read-only value.

STEP 5: The setting of feedback signal type

STEP 5.1: The setting of permanent magnet synchronous rotary motor

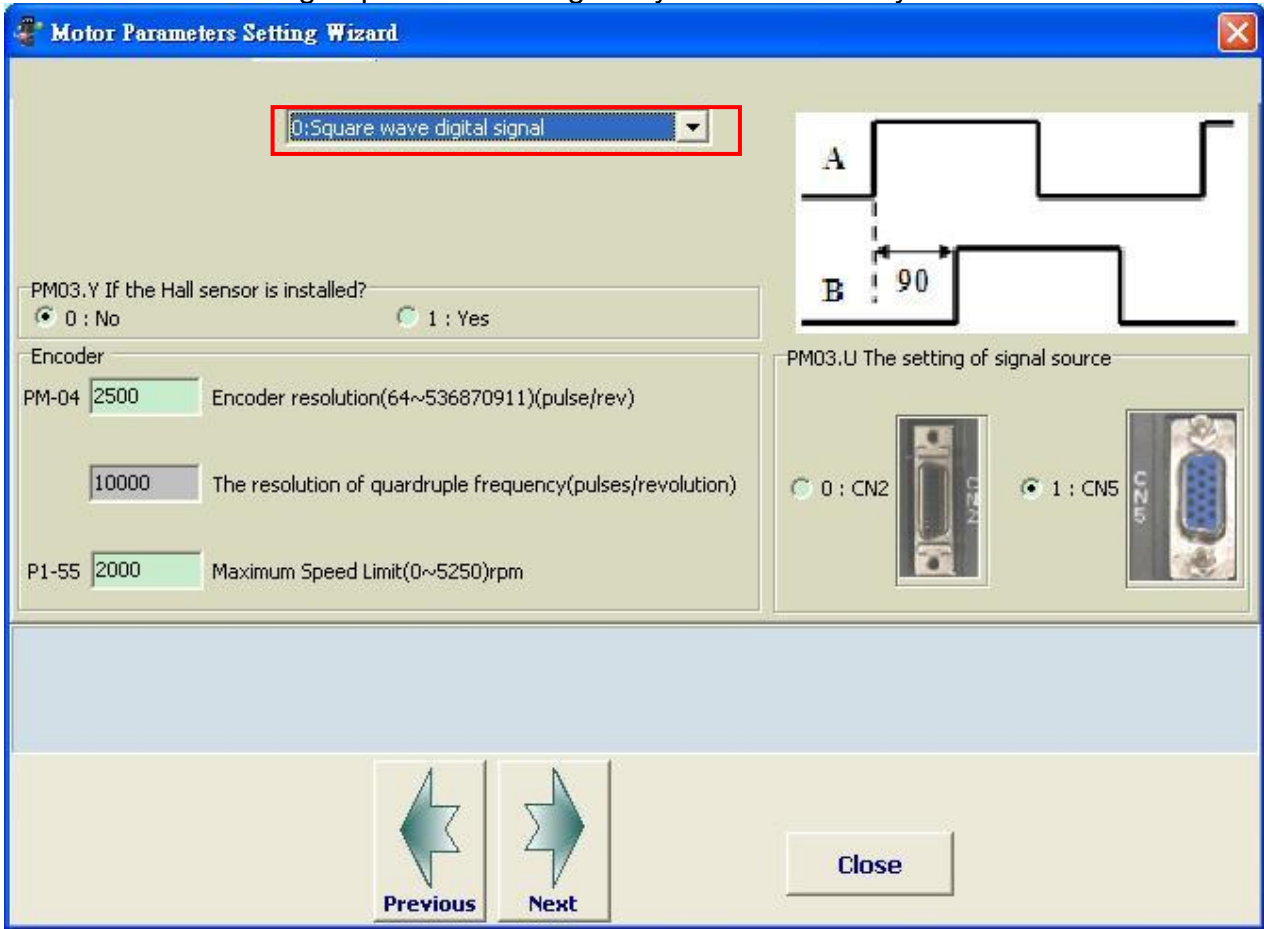

Select the encoder feedback signal type: square wave digital signal or sinusoid analog signal

STEP 5.1.1: The setting of square wave digital signal

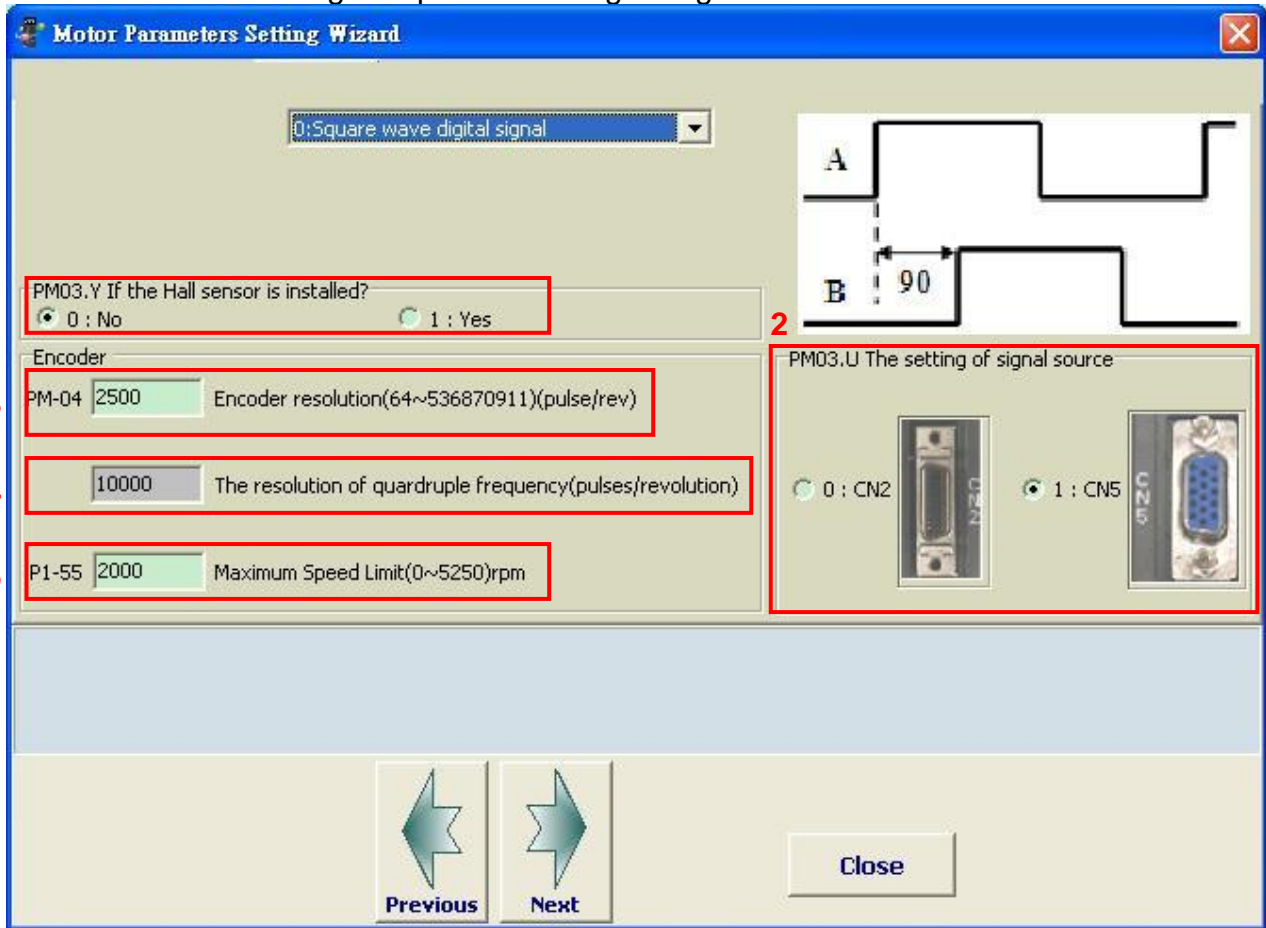

1. If the Hall sensor is installed: Select if the motor is installed Hall sensor.
2. The setting of signal source: Select the feedback signal source, CN2 or CN5
3. Encoder resolution (signal before quadrature process): The pulse number in one cycle of motor feedback; unit: *pulse/rev*
4. The resolution of quadruple frequency: It is the read-only value. Value = PM-04*4; Unit: *count/rev*
5. The maximum speed limit: The maximum speed limit of mechanism. Unite: rpm; range: $0 \sim \frac{5 \cdot 10^6 \cdot 60}{PM - 04}$ (motor maximum speed)*1.05 or (take the minimum value)

STEP 5.1.2: The setting of sinusoid analog signal

Motor Parameters Setting Wizard

1: Sinusoidal analog signal

PM03.Y If the Hall sensor is installed?

0 : No 1 : Yes

Encoder

PM-04 2500 Encoder resolution(64~536870911)(periods/rev)

PM-05 [11]:2048 The interpolation of signal converter box(4~2048)(\times)

5120000 The result after interpolation(pulses/revolution)

P1-55 2000 Maximum Speed Limit(0~5250)rpm

PM03.U The setting of signal source

0 : CN2 1 : CN5

Previous Next Close

1. If the Hall sensor is installed: Select if the motor is installed Hall sensor.
2. The setting of signal source: Its signal source is from CN2 port.
3. Encoder resolution (signal before quadrature process): The pulse number in one cycle of motor feedback; unit: *period/rev*
4. The interpolation of signal converter box: Setup the interpolation of signal converter box. It fine-cuts the sinusoid analog signal and transforms the signal into square wave signal which also enhances the resolution.
5. The result after interpolation: It is the read-only value. Value = PM-04*PM-05; unit: *count/rev*
6. The maximum speed limit: The maximum speed limit of mechanism. Range: 0~6000; unit: rpm

STEP 5.2: The setting of permanent magnet synchronous linear motor

STEP 5.2.1: The setting of square wave digital signal

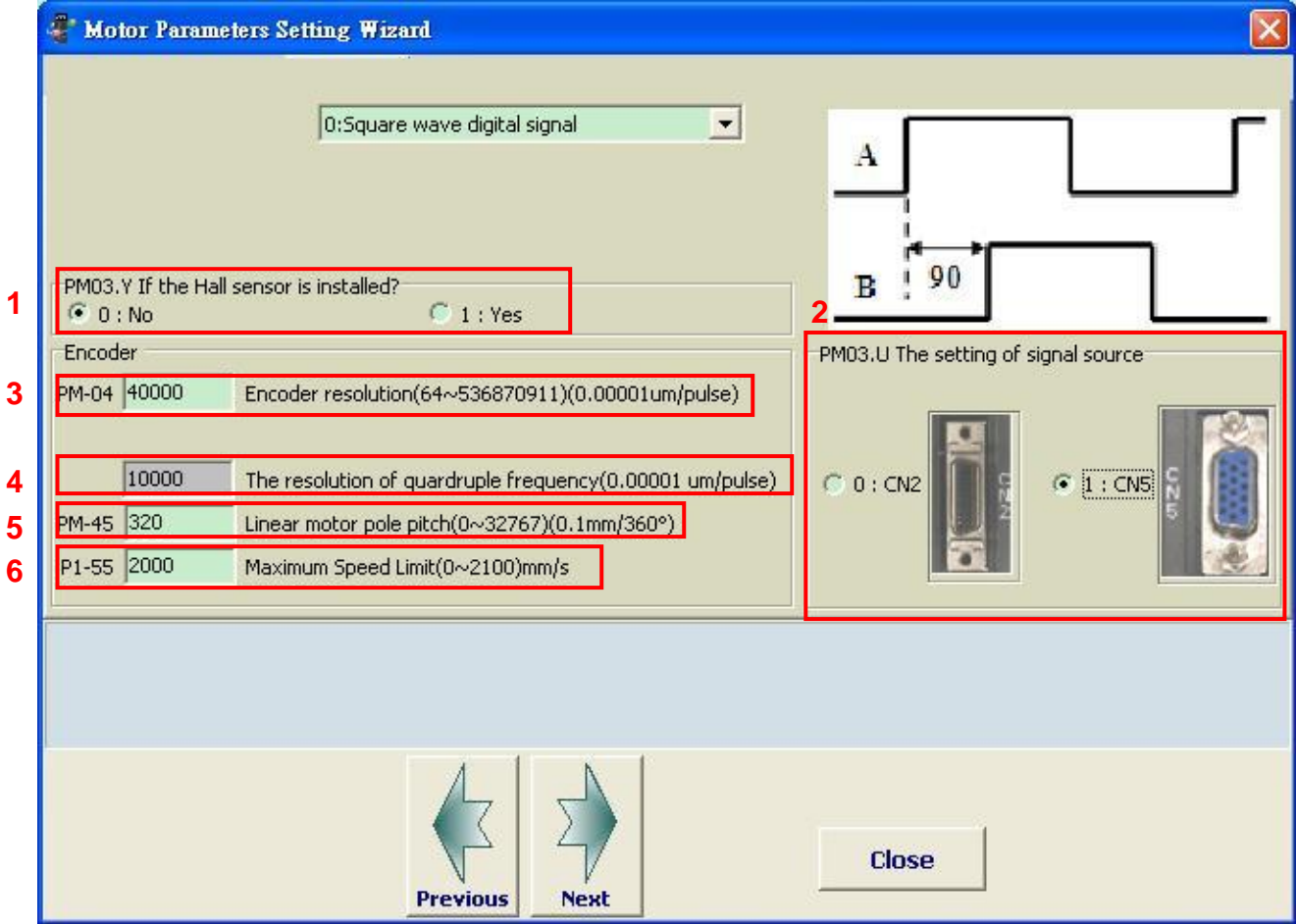

1. If the Hall sensor is installed: Select if the motor is installed Hall sensor.
2. The setting of signal source: Select the feedback signal source, CN2 or CN5
3. Encoder resolution (signal before quadrature process): The length of one pulse of linear scale feedback; unit: $10^{-5} \mu m / pulse$
For example, if the resolution of linear scale is $1 \mu m$ (signal after quadrature process), users should enter 400000 in the table; if it is $0.5 \mu m$, then users should enter 200000.
4. The resolution of quadruple frequency: It is the read-only value. Value = $PM-04/4$; Unit: $10^{-5} \mu m / count$
5. The pole pitch of permanent magnet synchronous linear motor. Range: 0~32767; unit: 0.1mm
6. The maximum speed limit: The maximum speed limit of mechanism. Range: 0~ PM-48
motor maximum speed*1.05 or $\frac{5 * PM - 04}{10^2}$ (take the minimum value); unit: $10^{-3} m / s$.

STEP 5.2.2: The setting of sinusoid analog signal

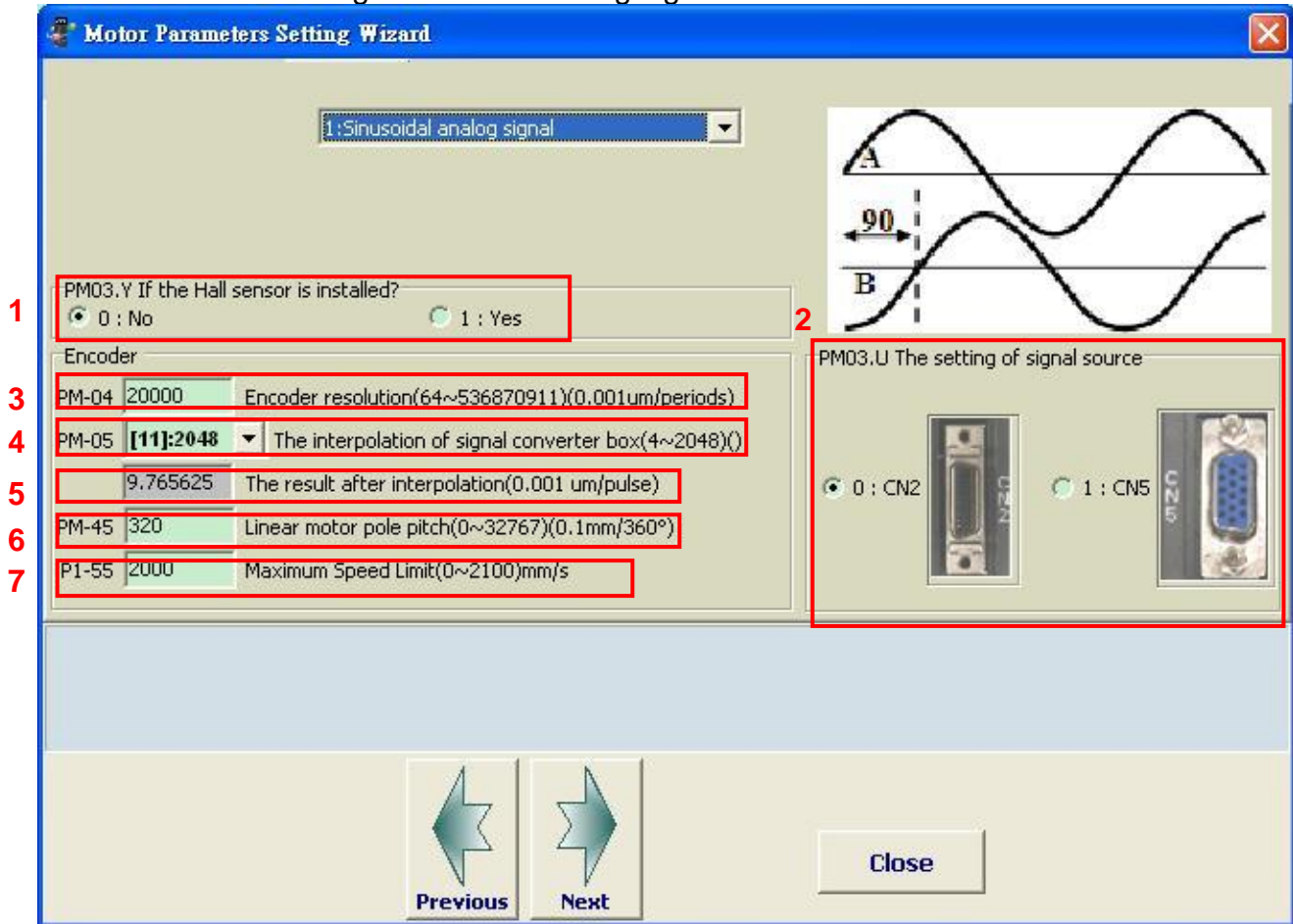

1. If the Hall sensor is installed: Select if the motor is installed Hall sensor.
2. The setting of signal source: Its signal source is from CN2 port only.
3. Encoder resolution: The length of one sinusoid cycle of linear scale feedback; unit:
 $10^{-3} \mu\text{m} / \text{period}$
4. The interpolation of signal converter box: Setup the interpolation of signal converter box. It fine-cuts the sinusoid analog signal and transforms the signal into square wave signal which also enhances the resolution.
5. The result after interpolation: It is the read-only value. Value = PM-04/PM-05*100; unit:
 $10^{-5} \mu\text{m} / \text{count}$
6. The pole pitch of permanent magnet synchronous linear motor. Input the pole pitch of permanent magnet synchronous linear motor. Range: 0~32767; unit: 0.1 mm
7. The maximum speed limit: input the maximum speed limit of mechanism; range:
0~15999; unit: $10^{-3} \text{m} / \text{s}$

STEP 6: Automatically detect parameters

STEP 6.1

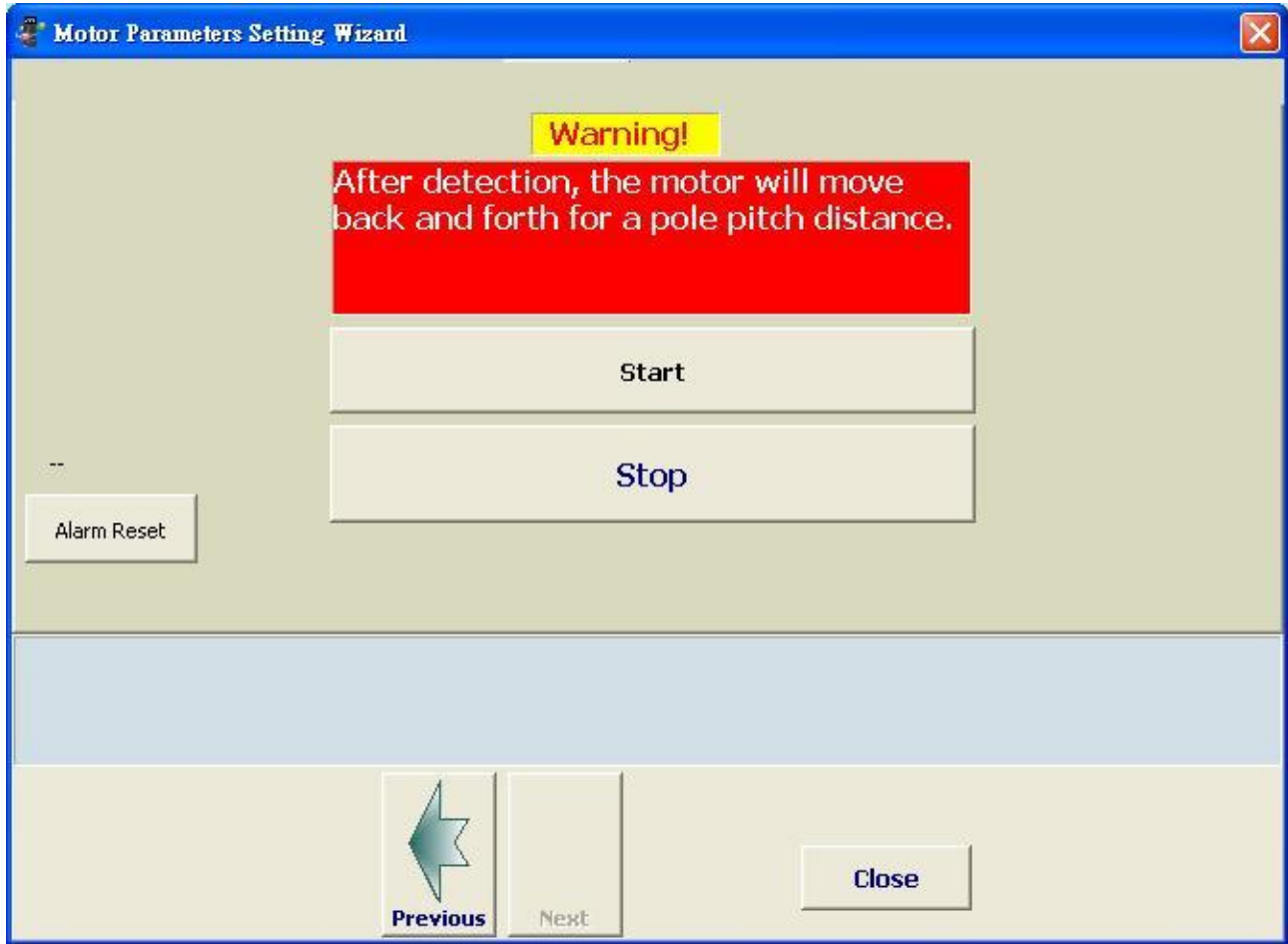

Press **START**, the software starts to detect electrical parameters of the motor. The motor will slightly wobble at first. Then, the linear motor moves back and forth for one pole pitch and the rotary motor rotates one cycle. Users shall pay attention to the direction the motor moves at the moment as it can be used to setup the definition of motor' s moving direction. Before the detection, please reserve the motor' s moving distance in advance.

During the detection, if an alarm occurs, please refer to Chapter 10 for troubleshooting. After conducting the corrective active, press **Previous** and then **Next** to clear the alarm.

The following common alarms are for reference.

AL051 : Auto detection of motor parameters is in error

Causes	Checking Method	Corrective Actions
When executing the function of PM-01, if the friction is too big, motor is stuck or entering wrong resolution and pitch pole, this alarm will occur.	<ol style="list-style-type: none"> 1. Check if motor pole pitch, encoder resolution and encoder type are entered correctly. 2. Check if motor is stuck during detection. 3. Check if the motor friction is too big. 4. Check if the feedback of linear scale is abnormal, the connection is breakdown, the scale is not installed properly or there is noise interference. 	<ol style="list-style-type: none"> 1. Enter the value which is the same as the actual one and activate the detection again. 2. The rotary motor will rotate at forward and reverse direction for one magnetic cycle during detection. The linear motor will move for a pitch forward and backward. Please preserve the moving distance before detection. 3. Chang another motor with more power. 4. Correct the problem of linear scale.

Check if the feedback of linear scale works properly through PC software.

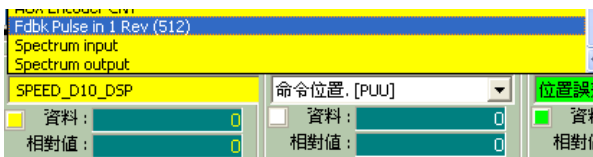

In monitor variable mode, press the **SHIFT** Key to pop up the menu. Select FDBK PULSE IN 1REV (512) and check 32BIT. This is the actual feedback pulse of linear scale (quadruple frequency). Manually move the fixed distance of linear motor. Observe the change of variables to see if the moving distance matches the linear scale resolution. For example, the linear scale resolution is 1um. If the linear motor is moved for 0.1m, the

value of FDBK PULSE IN 1REV (512) will be $\frac{0.1}{1*10^{-6}} = 100000$ pulse number.

If it has excessive error, please check if the linear scale has the problem that mentioned above.

AL024 : Encoder initial magnetic field error

Causes	Checking Method	Corrective Actions
The initial magnetic field is of the encoder in error (Signal, U, V, W of the encoder magnetic field is in error.)	<ol style="list-style-type: none"> 1. Check if the servo is properly grounded. 2. Check if the encoder cable separates from the power supply or the high-current circuit to avoid the interference. 3. Check if the shielding cables are used in the wiring of the encoder. 4. If it connects to Hall sensor, please check the wiring of Hall sensor. 	If issue persists, please send the drive back to the distributors or contact with Delta.

Judge the causes of alarm from Hall sensor. The followings are the description.

1. Check if the wiring of Hall sensor is correct.
2. If the motor connects to digital Hall sensor, the following methods can help to identify if digital Hall sensor can work properly.

In PC software, enter address 0xe37b and the value is 16bit. Bit1, bit2 and bit3 of this variable corresponds to the three-phase U, V and W of Hall sensor respectively. Move the motor will change the value.

The normal value changes regularly includes two situation mentioned below.

- i. (1,0,1) =>(1,0,0) =>(1,1,0) =>(0,1,0) =>(0,1,1) =>(0,0,1)
- ii. (0,0,1) =>(0,1,1) =>(0,1,0) =>(1,1,0) =>(1,0,0) =>(1,0,1)

If the value irregular changes, it means Hall sensor might have the problem that mentioned below.

1. The problem of interference: The value irregular changes.
2. If one of the following situations is established, such as the connection between Hall sensor and servo drive is broken, broken Hall sensor, wrong wiring, one of the value remains or the value changes but out of order, e.g. the value shows (1, 1, 1) and (0, 0, 0), the alarm (AL.024) occurs.

AL031 : Incorrect wiring of the motor power line U, V, W, GND

Causes	Checking Method	Corrective Actions
The wiring of U, V, W, GND of the motor is incorrect connected.	Check if U, V, W of the motor is incorrect connected	Follow the user manual to correctly wire U, V, W and make sure it is grounded.

STEP 6.2: Set the motor moving direction

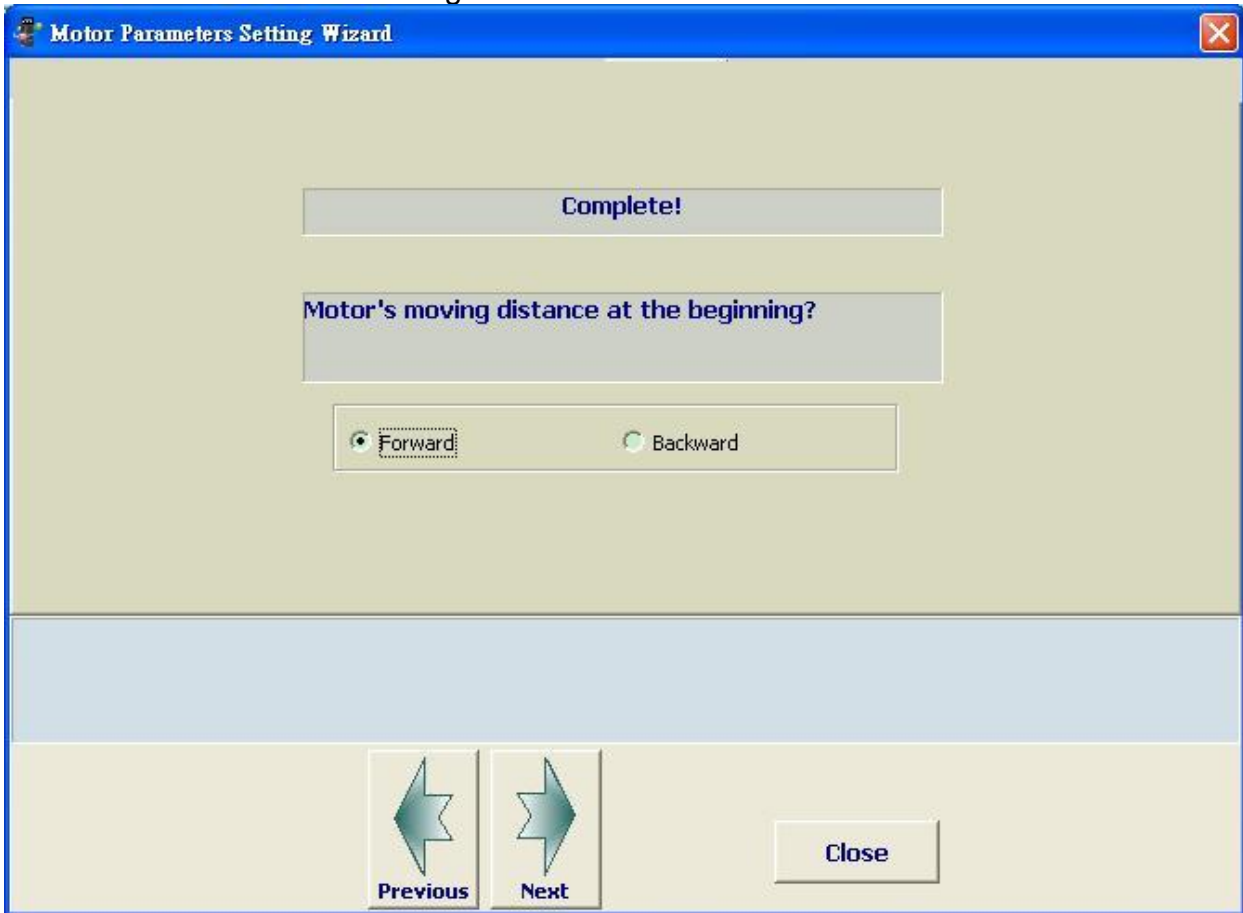

When the detection is completed, the above page pops up. Users self-define the first moving direction as backward or forward direction. The setting value is saved in Z item of P1-01.

STEP 6.3:

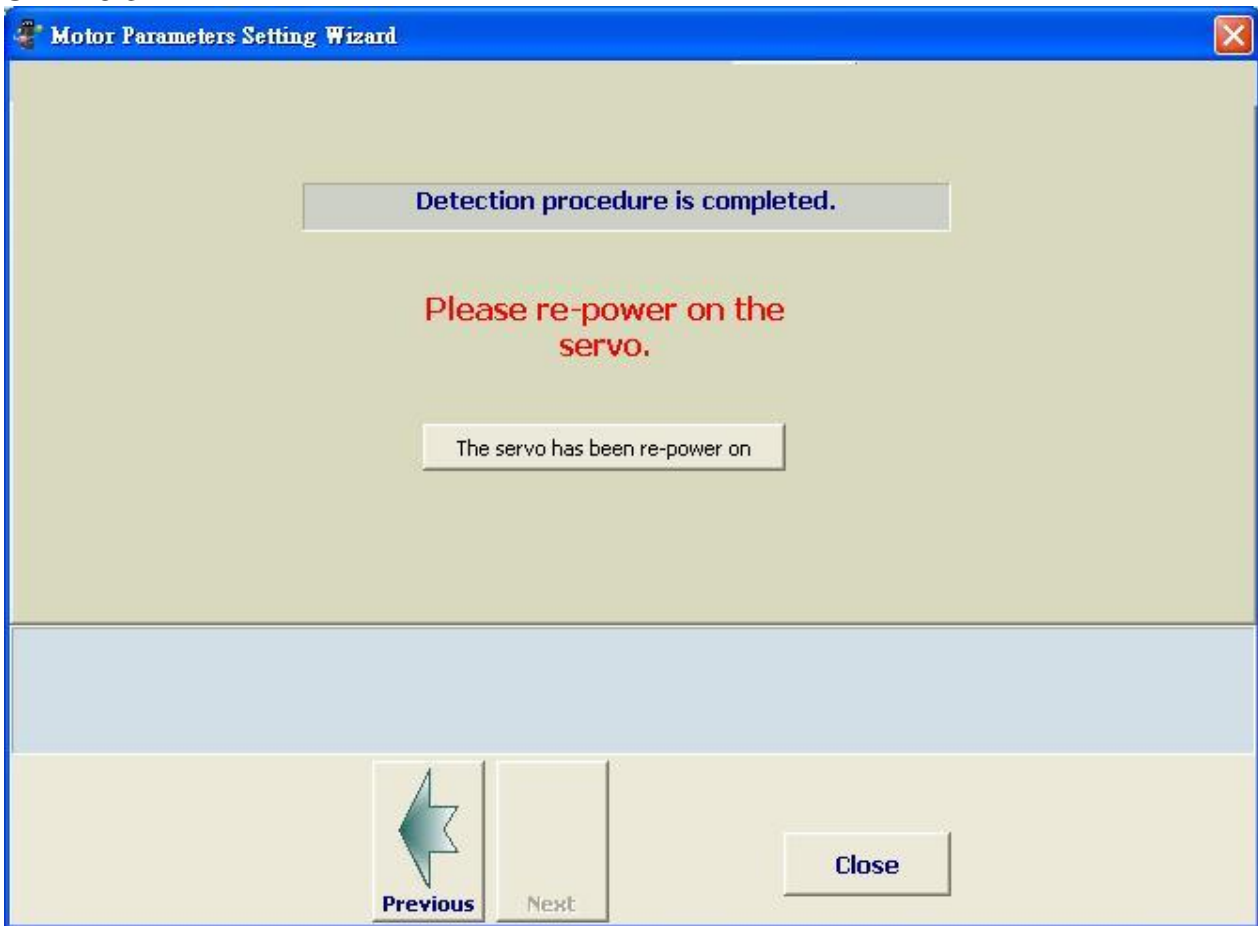

After the auto detection procedure is completed and re-servo on the servo drive, please press **The servo has been re-power on** and proceed to the next step.

STEP7: Edit motor parameters

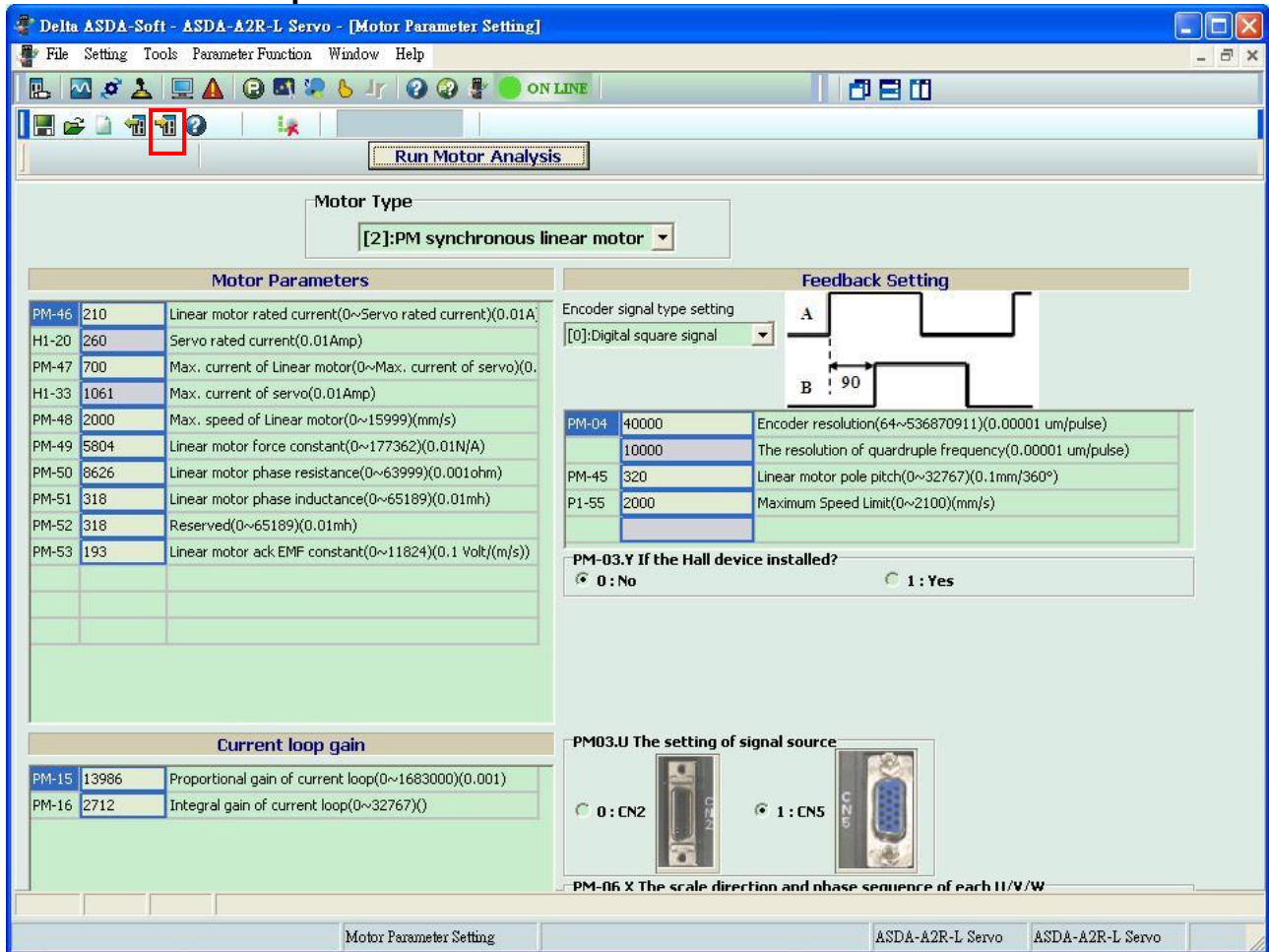

This page shows motor parameters and the value from auto-detection. The listed parameters are effective. If users desire to change the motor parameter, simply enter the value and press **Write into the Servo** will do.

STEP8: Gain adjustment of linear motor
 Open PC software and select **Auto Gain Tuning**.

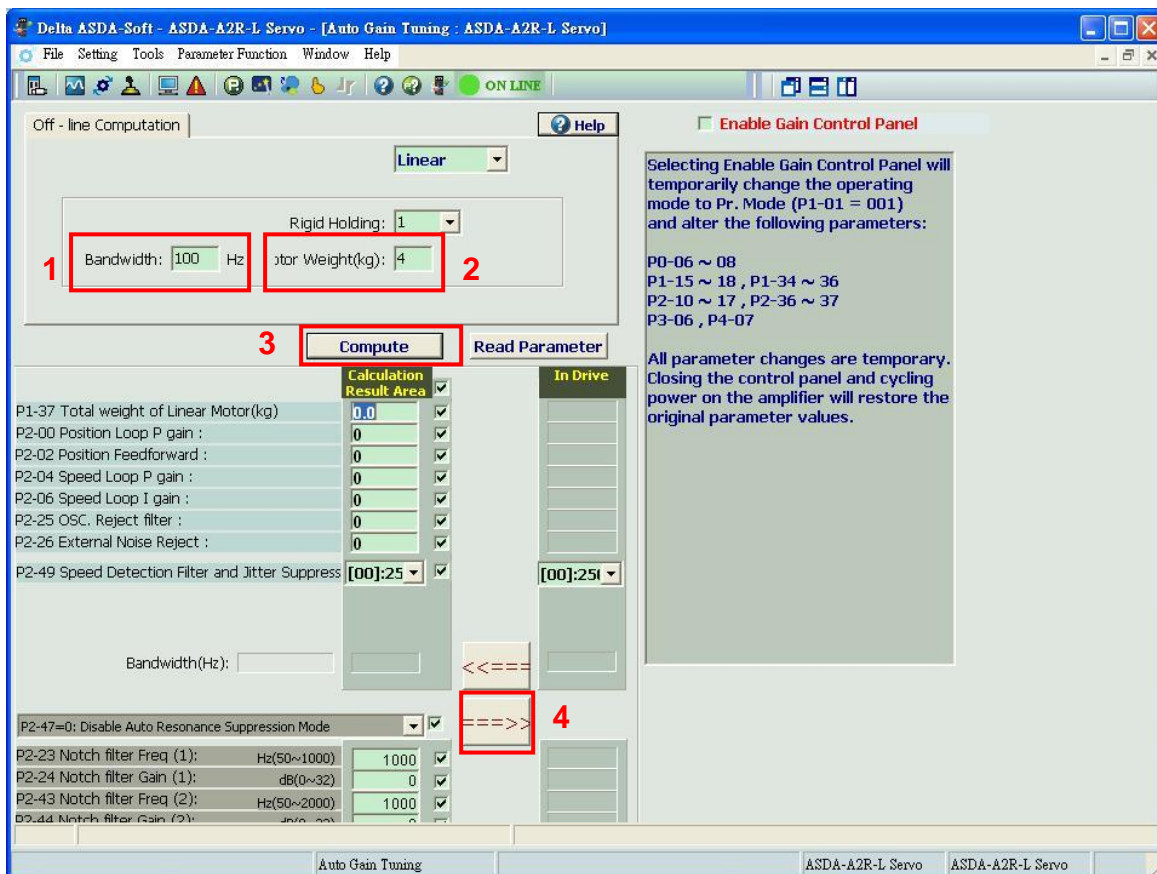
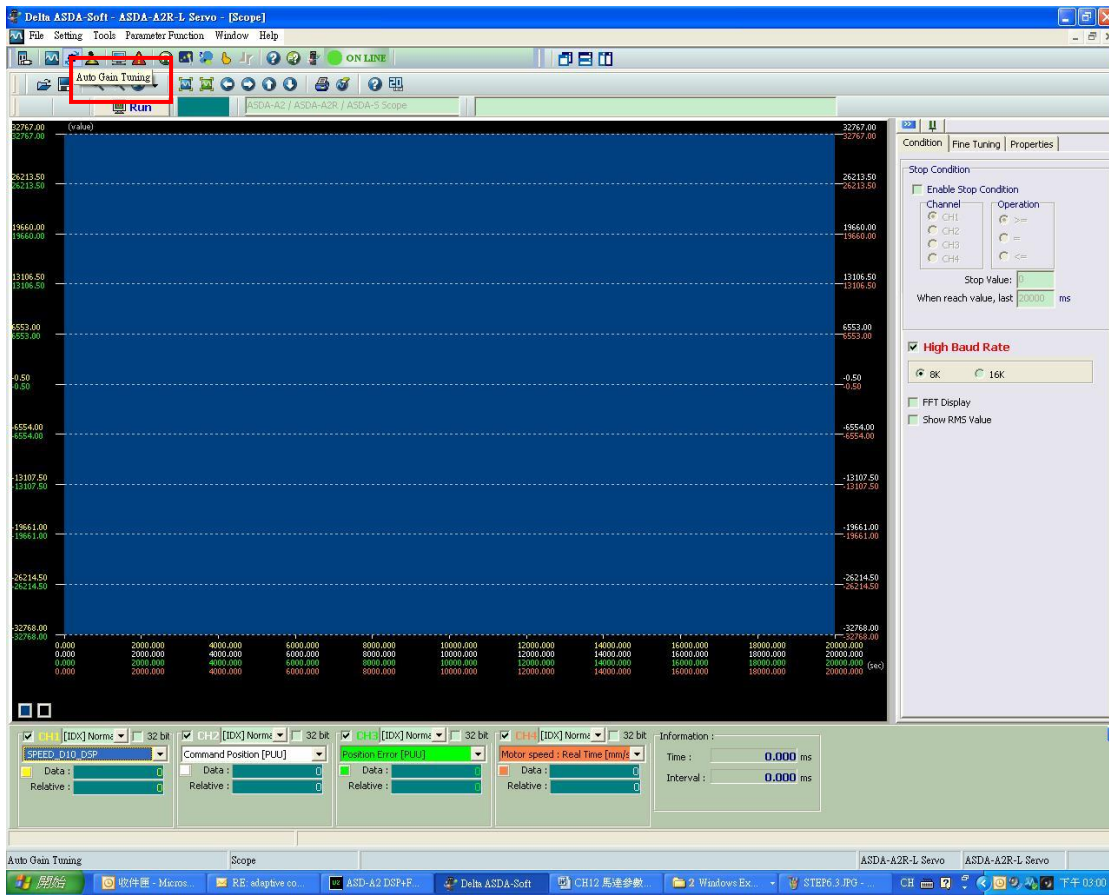

1. Set the proper bandwidth
2. Set the proper weight of linear motor and the total weight of system loading. Unit: kg
The estimated input value should close to the actual weight. If the input value is much smaller than the actual one, the motor might tremble during the operation; if the input value is much bigger than the actual one, it might cause resonance.
3. Gain computing
The software automatically computes the gain.
4. Download to servo drive
The gain value is not effective until it is downloaded to servo drive.

**Estimate the actual weight of linear motor
Enable Gain Control Panel:**

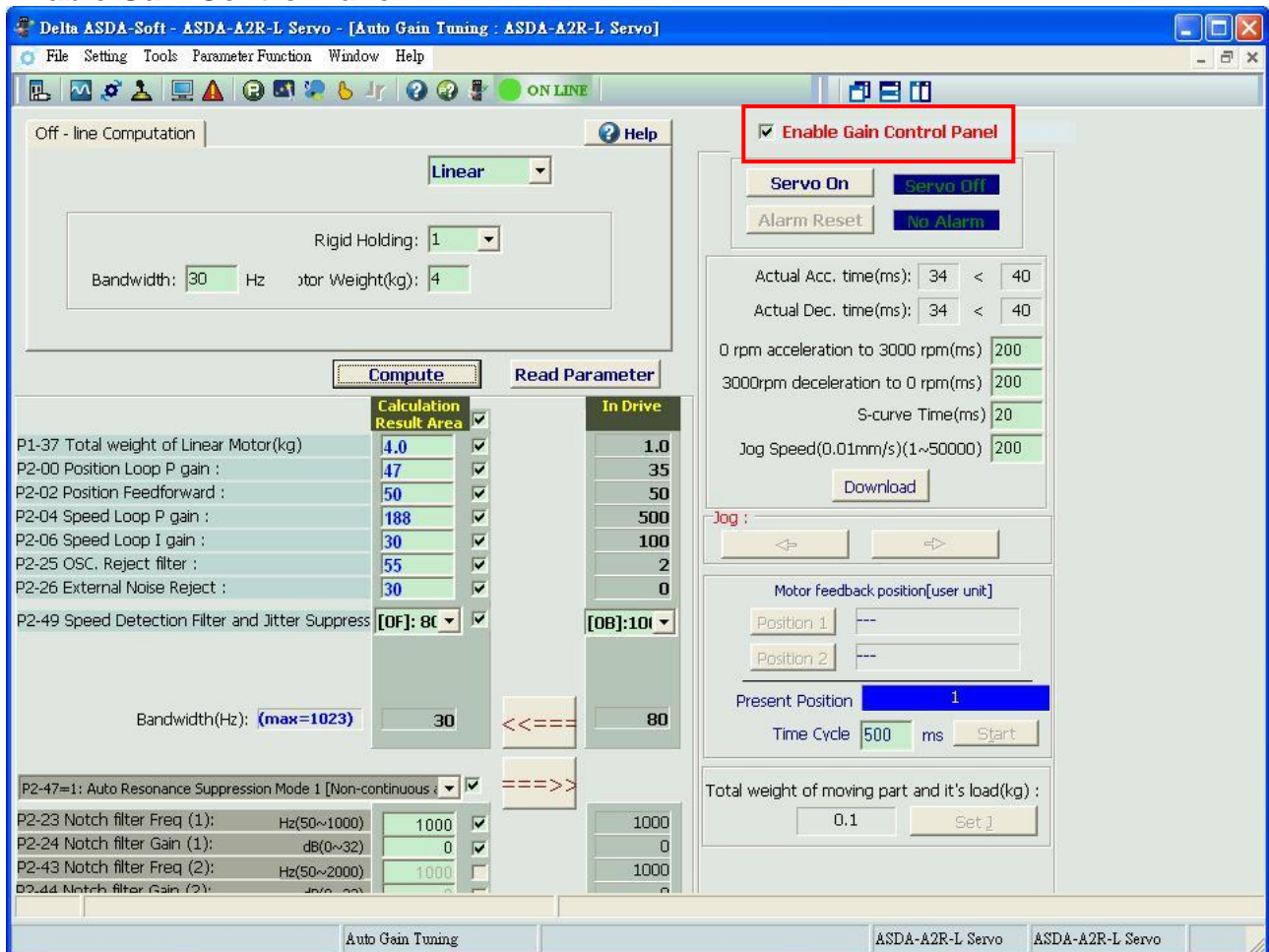

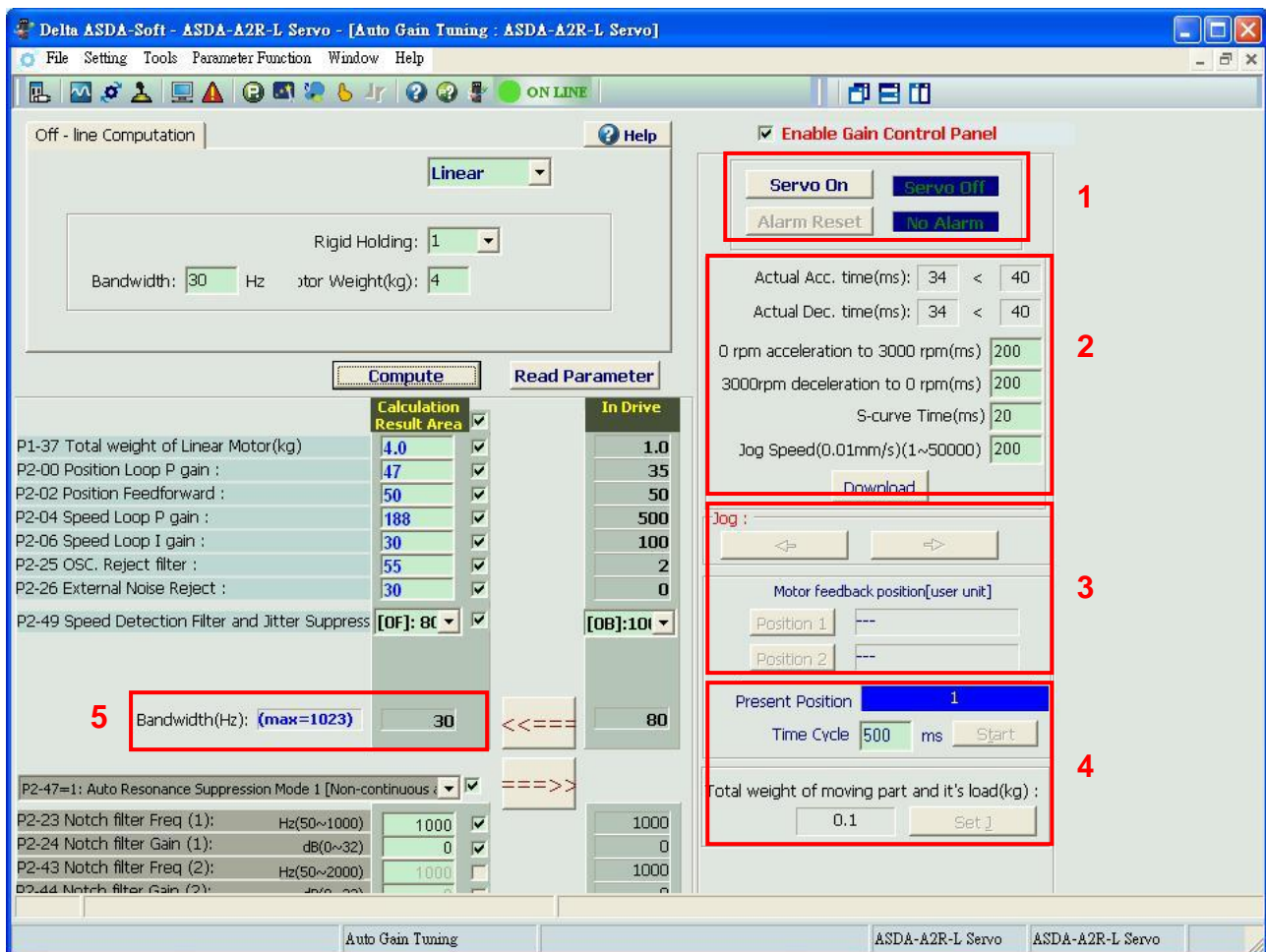

1. Activate the servo drive
2. Setup the speed curve of weight estimation and press **Download**.
For example, set the Jog speed to 10000 which means the operation speed is 100mm/s.
3. Decide the back and forth moving distance
Use Jog function to enable the motor moves back and forth between two fixed points and estimate the weight. And the distance between two fixed points can be determined by Position 1 and 2.
4. Start
Press the **Start** Key and the motor starts to move back and forth. In the item of the **total weight of movable section and load**, users can see the value starts to change. It means it is in weight estimation. When the value is stable, it can stop the motor. Press **Set J** to complete the estimation.
If it is in weight estimation, but the value in **total weight of movable section and load** remains, the speed and acceleration / deceleration constant should be increased in STEP 2 before conducting the estimation.
5. Setup the bandwidth and gain.

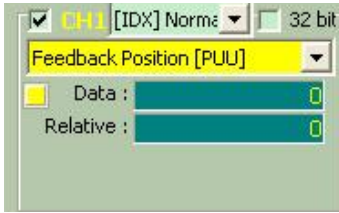
STEP9: P2-35 (The setting of preventing excessive position error)

With the proper setting of P2-35, it can effectively prevent the sudden unintended acceleration.

The motor can run at the maximum speed within the maximum limit. Observe the variable which is the approximate value of encoder error through PC software and then set a buffer range to P2-35.

For example, when the motor runs to the maximum speed, the maximum encoder error is 25000, the range of P2-35 can be set between 35000 and 40000.

STEP10: P1-74.U (The filter setting of CN5 linear scale) (digit in thousands)

When the feedback signal of CN5 connector is the AB type square wave from motor encoder or the signal of linear scale, setup the proper digital filter can effectively suppress the noise. Users can refer to the maximum approximate value of feedback pulse and setup the buffer value of P1-74.U. The setting value of U and its corresponding filter frequency:

U = 1 (20Mhz)

U = 2 (10Mhz)

U = 3 (6.66Mhz)

U = 4 (1.66Mhz)

U = 5 (833Khz)

U = 6 (416Khz)

Take filter frequency 20MHz (50ns) as the example:

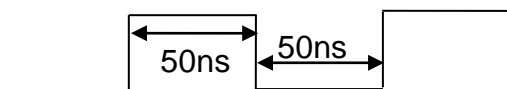

The single phase with the width smaller than 50ns will be filtered.

For example, when connecting to 1um of linear scale, the maximum speed of motor is 1m/s. At the moment, the maximum moving frequency of linear scale is 1MHz (quadruple frequency) and the minimum width of single phase pulse is 2us (= 500khz). Consider the change of pulse width or the motor's moving speed might exceed the upper limit, thus, setup a buffer range (set U to 4).

STEP11: Output A/B pulse by pass from CN5: P1-74.Y (digit in tens)

When the feedback signal of CN5 connector is the AB type square wave from motor encoder or the signal of linear scale, output A/B pulse by pass from CN5 in order to transmit a more realistic signal to the controller. Set P1-74.Y to 1 will do.

STEP12: Parameters that are commonly used in A2R

Execution	Related parameters
Aiming to the excessive position error, the parameter will activate the alarm for protection.	P2-35
Aiming to the problem of severe noise from low-resolution motor, it is suggested to set P2-84 to 111 to reduce the interference.	P2-84
Output A/B pulse by pass from CN5 When the motor feedback signal is from CN5, then output A/B pulse signal BYPASS will be the most ideal and realistic signal output	P1-74 Set P1-74.Y to 1
When the motor feedback signal is from CN5, setup the appropriate filter function of linear scale can prevent the interference.	P1-74.U (digit in thousands)
Examination of leak pulse: When the motor feedback signal is square wave digital signal, it might cause the problem of leak phase. The motor might move to the wrong position or even out of control. At this moment, set P2-81 to 1 can examine the problem of leak pulse. If the amount of leak pulse exceeds the value of P2-82, AL.057 will occur.	P2-81, P2-82, P2-83
No Hall sensor. Input the current to detect the position of initial magnetic field.	PM-11
Setup the sensor of motor temperature	PM-22

12.2 Panel Setup Procedure (without PC Software)

The setting of permanent magnet synchronous rotary motor

1. Press the MODE Key to select parameter function mode.	P0-00
2. Press the SHIFT Key to select parameter group mode to P2 group.	P2-00
3. Press the UP Key to select the parameter to P2-08.	P2-08
4. Press the SET Key to show the value.	00000
5. Use SHIFT , UP and DOWN Keys to set the value to 40. Then press the SET Key to save the value.	00040
6. Press the SHIFT Key to select the parameter group mode to PM group.	Pn-00
7. Use the UP and DOWN Key to select the parameter to PM-00	Pn-00
8. Press the SET Key to show the value	
9. Use SHIFT , UP and DOWN Keys to set the value to 0 and press the SET Key.	00000
10. Use UP and DOWN Keys to select the parameter to PM-31.	Pn-31
11. Press the SET Key to show the value.	
12. Use SHIFT , UP and DOWN Keys to setup the rated speed of the motor (unit: rpm; range: 0~3000). Then, press the SET Key to save it.	
13. Use UP and DOWN Keys to select the parameter to PM-32.	Pn-32
14. Press the SET Key to show the value.	
15. Use SHIFT , UP and DOWN Keys to setup the maximum speed of the motor (unit: rpm; range: 0~6000). Then, press the SET Key.	
16. Use UP and DOWN Keys to select the parameter to PM-33	Pn-33
17. Press the SET Key to show the value.	
18. Use SHIFT , UP and DOWN Keys to setup the torque constant of the motor (unit: 0.001Nm/A; range: 0~13850). Then, press the SET Key to save the value.	
19. Use UP and DOWN Keys to select the parameter to PM-34.	Pn-34
20. Press the SET Key to show the value.	
21. Use SHIFT , UP and DOWN Keys to setup the motor inertia (unit: $10^{-7} kg \cdot m^2$). Then, press the SET Key to save it.	
22. Use UP and DOWN Keys to select the parameter to PM-29	Pn-29
23. Press the SET Key to show the value.	
24. Use SHIFT , UP and DOWN Keys to setup the rated current of the motor. (unit: 0.01A; range: 0~the rated current of the servo drive). Then, press the SET Key to save it.	

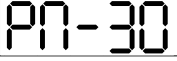
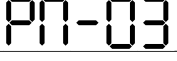
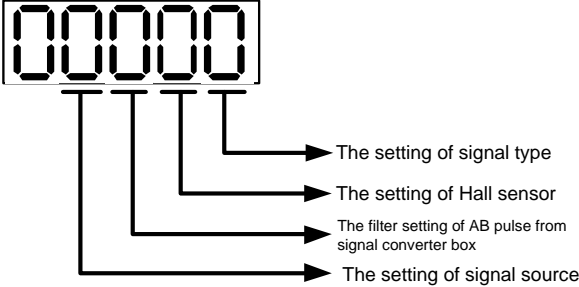
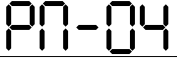
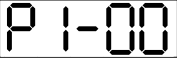
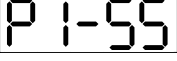
<p>25. Use UP and DOWN Keys to select the parameter to PM-30</p>	
<p>26. Press the SET Key to show the value.</p>	
<p>27. Use SHIFT, UP and DOWN Keys to setup the maximum current of the motor (unit: 0.01A; range: 0~the maximum current of the servo drive). Then, press the SET Key to save it.</p>	
<p>28. Use UP and DOWN Keys to select the parameter to PM-03</p>	
<p>29. Press the SET Key to show the value.</p>	
<p>30. Use SHIFT, UP and DOWN Keys to setup the encoder feedback type and press the SET Key to save it. The parameter setting is as the followings.</p>  <p>The setting of signal type: 0 = Square wave digital signal 1 = Sinusoid analog signal</p> <p>The setting of Hall sensor: 0 = without Hall sensor 1 = with Hall sensor</p> <p>The filter setting of AB pulse from signal converter box: 0 = BYPASS 1 = 16M 2 = 8M 3 = 3M</p> <p>The setting of signal source: 0 = comes from CN2 1 = comes from CN5</p>	
<p>31. Use UP and DOWN Keys to select the parameter to PM-04</p>	
<p>32. Press the SET Key to show the value.</p>	
<p>33. Use SHIFT, UP and DOWN Keys to setup the encoder resolution (single-phase resolution). Then, press the SET Key to save it.</p> <p>Unit: <i>pulse/rev</i> (square wave digital signal) Unit: <i>periods/rev</i> (sinusoid analog signal)</p>	
<p>34. Press the SHIFT Key to select the parameter group mode to P1 group</p>	
<p>35. Use UP and DOWN Keys to select the parameter to P1-55</p>	

36. Press the SET Key to show the value.	
37. Use SHIFT , UP and DOWN Keys to setup the maximum speed of the mechanism (unit: rpm; range: 0~the maximum speed of the motor). Then, press the SET Key to save it.	
38. Re-servo ON the servo drive.	
39. Press the MODE Key to select the parameter function mode.	P0-00
40. Press the SHIFT Key to select the parameter group mode to P2 group	P2-00
41. Press the UP Key to select the parameter to P2-08.	P2-08
42. Press the SET Key to show the value.	00000
43. Use SHIFT , UP and DOWN Keys to set the value to 40. Then, press the SET Key to save the value.	00040
44. Press the SHIFT Key to select the parameter group mode to PM group.	PM-00
45. Press the SET Key to show the value.	00000
46. Use SHIFT , UP and DOWN Keys to set the value to 01 and press the SET Key to save the value.	00001
47. After servo ON (P2-30=1), the motor starts to estimate. ※ The motor will operate one cycle in forward and reverse direction.	
48. When AL.050 occurs (see the figure on the right), it means the estimation is completed. Please re-servo ON the servo drive. ※If other ALARM occurs, please refer to the table of troubleshooting.	AL050

The setting of permanent magnet synchronous linear motor

1. Press the MODE Key to select the parameter function mode.	P0-00
2. Press the SHIFT Key to select the parameter group mode to P2 group.	P2-00
3. Press the UP Key to select the parameter to P2-08.	P2-08
4. Press the SET Key to show the value.	00000
5. Use SHIFT , UP and DOWN Keys to set the value to 40. Then, press the SET Key to save the value.	00040
6. Press the SHIFT Key to select the parameter group mode to PM group.	P7-00
7. Use UP and DOWN Keys to select the parameter to PM-00.	P7-00
8. Press the SET Key to show the value.	
9. Use SHIFT , UP and DOWN Keys to set the value to 2 and press the SET Key.	00002
10. Use UP and DOWN Keys to select the parameter to PM-48.	P7-48
11. Press the SET Key to show the value.	
12. Use SHIFT , UP and DOWN Keys to set the maximum speed of the motor (unit: 10^{-3} m/s; range: 0~15999) and press the SET Key.	
13. Use UP and DOWN Keys to select the parameter to PM-49	P7-49
14. Press the SET Key to show the value.	
15. Use SHIFT , UP and DOWN Keys to set the motor force constant (unit: 0.01N/A; range: 0~177362) and press the SET Key to save it.	
16. Use UP and DOWN Keys to select the parameter to PM-46	P7-46
17. Press the SET Key to show the value.	
18. Use SHIFT , UP and DOWN Keys to set the rated current of the motor (unit: 0.01A; range: 0~the rated current of the servo drive). Then, press the SET Key to save it.	
19. Use UP and DOWN Keys to select the parameter to PM-47.	P7-47
20. Press the SET Key to show the value.	
21. Use SHIFT , UP and DOWN Keys to setup the maximum current of the motor (unit: 0.01A; range: 0~the maximum current of the servo drive). Then, press the SET Key to save it.	
22. Use UP and DOWN Keys to select the parameter to PM-45.	P7-45
23. Press the SET Key to show the value.	
24. Use SHIFT , UP and DOWN Keys to setup the motor pole pitch (unit: 0.1mm/360°; range: 0~32767). Then, press the SET Key to save it.	
25. Use UP and DOWN Keys to select the parameter to PM-03	P7-03

26. Use **SHIFT**, **UP** and **DOWN** Keys to setup the encoder feedback type. Then, press the **SET** Key to save it. The parameter setting is as the followings.

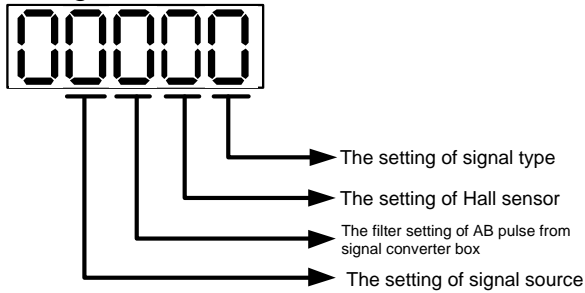

The setting of signal type:
 0 = square wave digital signal
 1 = sinusoid analog signal

The setting of Hall sensor:
 0 = without Hall sensor
 1 = with Hall sensor

The filter setting of AB pulse from signal converter box:
 0 = BYPASS
 1 = 16M
 2 = 8M
 3 = 3M

The setting of signal source:
 0 = comes from CN2
 1 = comes from CN5

27. Use **UP** and **DOWN** Keys to select the parameter to PM-04

PM-04

28. Press the **SET** Key to show the value.

29. Use **SHIFT**, **UP** and **DOWN** Keys to setup the encoder resolution (single-phase resolution). Then, press the **SET** Key to save it.

$10^{-5} \mu\text{m}/\text{pulse}$ (square wave digital signal),
 $10^{-3} \mu\text{m}/\text{period}$ (sinusoid analog signal)

30. Press the **SHIFT** Key to select the parameter group to P1 group.

P 1-00

31. Use **UP** and **DOWN** Keys to select the parameter to P1-55

P 1-55









32. Press the **SET** Key to show the value.

33. Use **SHIFT**, **UP** and **DOWN** Keys to setup the maximum speed of the mechanism (unit: 10^{-3}m/s ; range: 0~the maximum speed of the motor). Then, press the **SET** Key to save it.

34. Re-servo ON the servo drive.

35. Press the **MODE** Key to select parameter function mode.

PO-00

36. Press the SHIFT Key to select parameter group mode to P2 group.	
37. Press the UP Key to select the parameter to P2-08.	
38. Press the SET Key to show the value.	
39. Use SHIFT , UP and DOWN Keys to set the value to 40. Then, press the SET Key to save the value.	
40. Press the SHIFT Key to select the parameter group mode to PM group.	
41. Press the SET Key to show the value.	
42. Use SHIFT , UP and DOWN Keys to set the value to 01. Then, press the SET Key to save the value.	
43. After servo ON (P2-30=1), the motor starts to estimate automatically. ※The motor moves back and forth for one pole pitch.	
44. When AL.050 occurs (see the figure on the right), it means the estimation is completed. Please re-servo ON the servo drive. ※If other ALARM occurs, please refer to the table of troubleshooting.	

Appendix A Accessories

■ Power Connector

Delta Part Number: **ASDBCAPW0000**

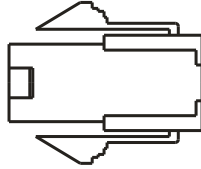

Title	Part No.	Manufacturer
Housing	C4201H00-2*2PA	JOWLE
Terminal	C4201TOP-2	JOWLE

Delta Part Number: **ASDBCAPW0100**

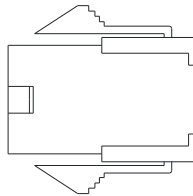

Title	Part No.	Manufacturer
Housing	C4201H00-2*3PA	JOWLE
Terminal	C4201TOP-2	JOWLE

Delta Part Number: **ASD-CAPW1000**

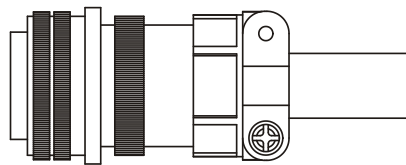

3106A-20-18S

Delta Part Number: **ASD-CAPW2000**

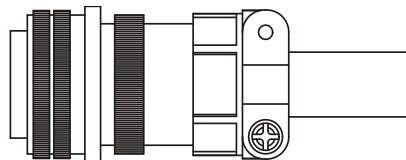

3106A-24-11S

■ Power Cable

Delta Part Number: **ASD-ABPW0003, ASD-ABPW0005**

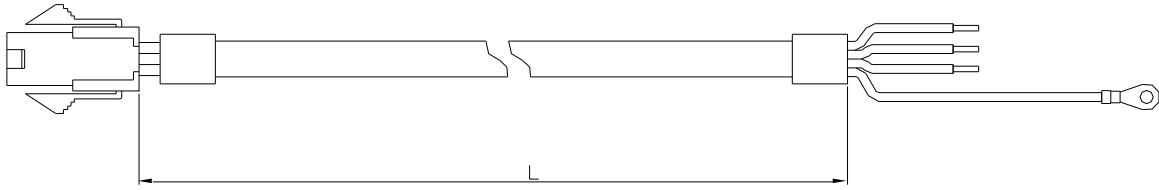

Title	Part No.	Manufacturer
Housing	C4201H00-2*2PA	JOWLE
Terminal	C4201TOP-2	JOWLE

Title	Part No.	L	
		mm	inch
1	ASD-ABPW0003	3000 ± 100	118 ± 4
2	ASD-ABPW0005	5000 ± 100	197 ± 4

Delta Part Number: **ASD-ABPW0103, ASD-ABPW0105**

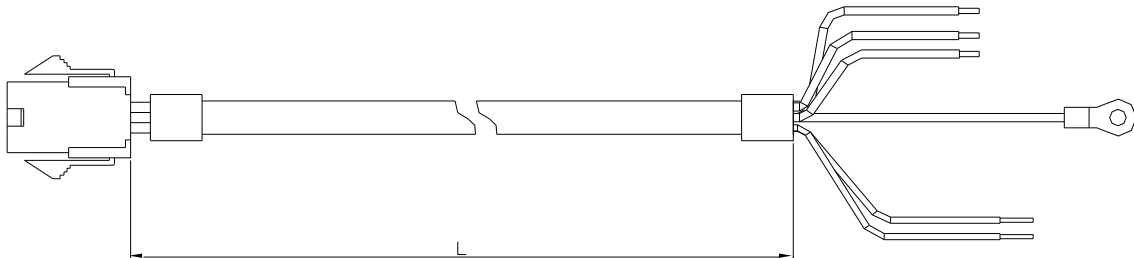

Title	Part No.	Manufacturer
Housing	C4201H00-2*3PA	JOWLE
Terminal	C4201TOP-2	JOWLE

Title	Part No.	L	
		mm	inch
1	ASD-ABPW0103	3000 ± 100	118 ± 4
2	ASD-ABPW0105	5000 ± 100	197 ± 4

Delta Part Number: **ASD-CAPW1003, ASD-CAPW1005**

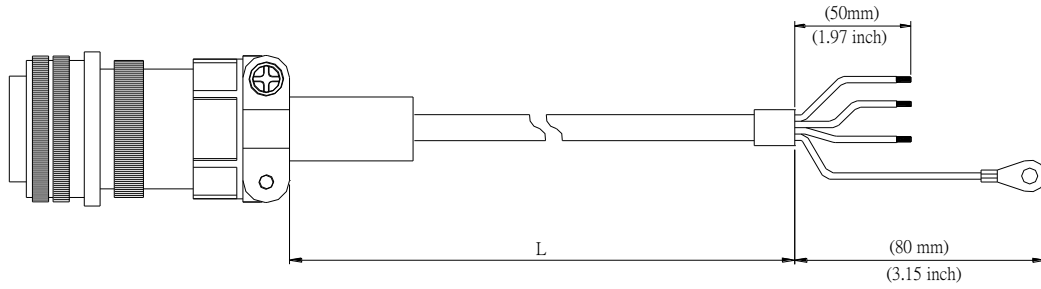

Title	Part No.	Straight	L	
			mm	inch
1	ASD-CAPW1003	3106A-20-18S	3000 ± 100	118 ± 4
2	ASD-CAPW1005	3106A-20-18S	5000 ± 100	197 ± 4

Delta Part Number: **ASD-CAPW1103, ASD-CAPW1105**

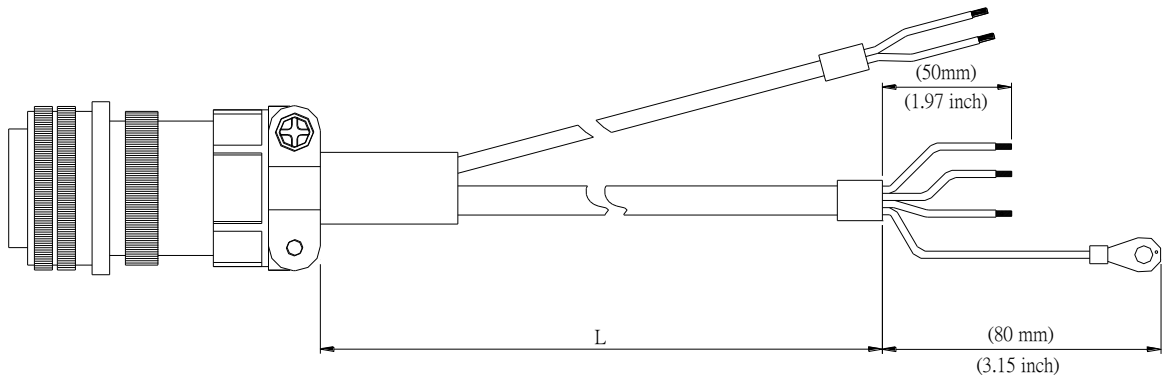

Title	Part No.	Straight	L	
			mm	inch
1	ASD-CAPW1103	3106A-20-18S	3000 ± 100	118 ± 4
2	ASD-CAPW1105	3106A-20-18S	5000 ± 100	197 ± 4

Delta Part Number: **ASD-A2PW1003, ASD-A2PW1005**

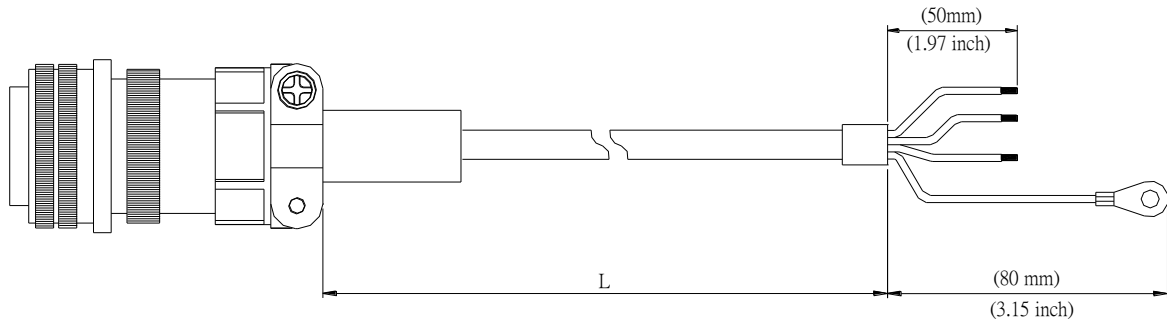

Title	Part No.	Straight	L	
			mm	inch
1	ASD-A2PW1003	3106A-20-18S	3000 ± 100	118 ± 4
2	ASD-A2PW1005	3106A-20-18S	5000 ± 100	197 ± 4

Delta Part Number: **ASD-A2PW1103, ASD-A2PW1105**

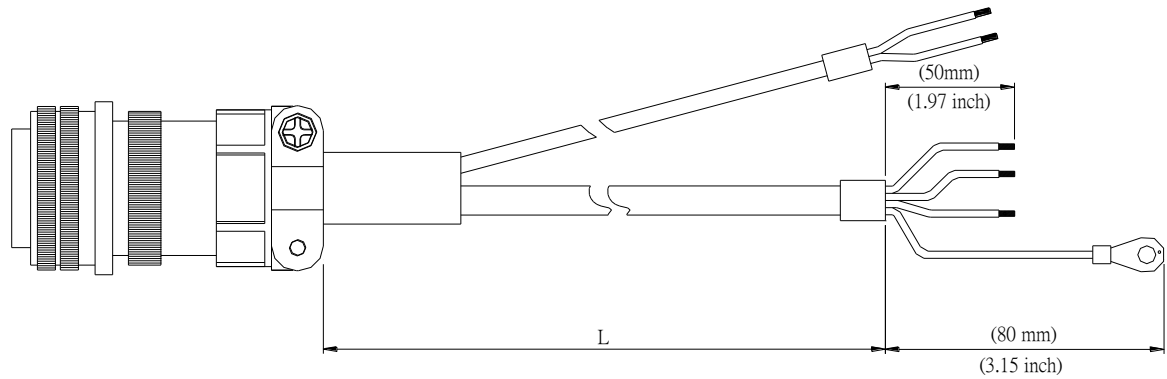

Title	Part No.	Straight	L	
			mm	inch
1	ASD-A2PW1103	3106A-20-18S	3000 ± 100	118 ± 4
2	ASD-A2PW1105	3106A-20-18S	5000 ± 100	197 ± 4

Delta Part Number: **ASD-CAPW2003, ASD-CAPW2005**

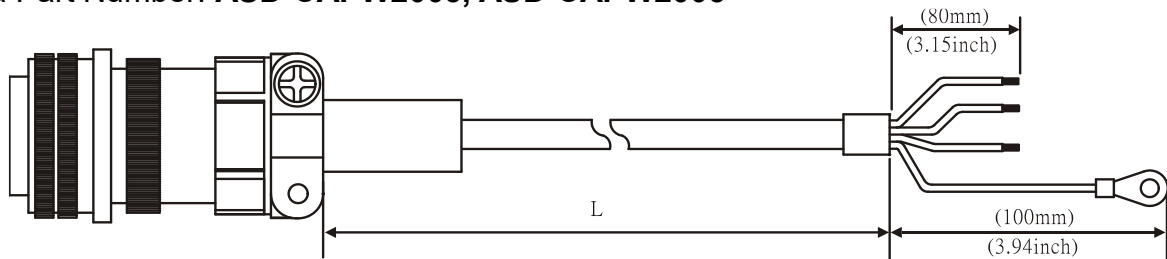

Title	Part No.	Straight	L	
			mm	inch
1	ASD-CAPW2003	3106A-24-11S	3000 ± 100	118 ± 4
2	ASD-CAPW2005	3106A-24-11S	5000 ± 100	197 ± 4

Delta Part Number: **ASD-CAPW2103, ASD-CAPW2105**

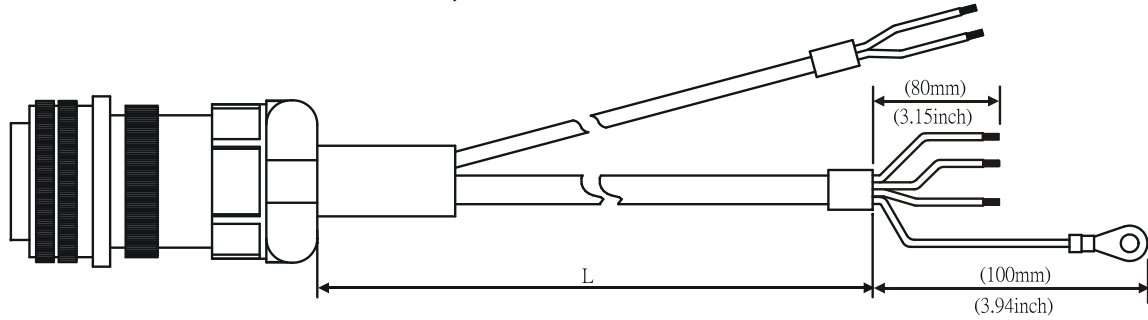

Title	Part No.	Straight	L	
			mm	inch
1	ASD-CAPW2103	3106A-24-11S	3000 ± 100	118 ± 4
2	ASD-CAPW2105	3106A-24-11S	5000 ± 100	197 ± 4

Encoder Connector

Delta Part Number: **ASD-ABEN0000**

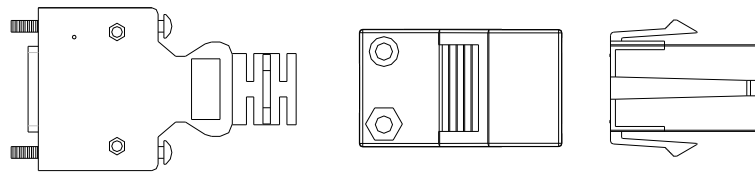

Title		Part No.	Manufacturer
MOTOR SIDE	Housing	AMP (1-172161-9)	AMP
	Terminal	AMP (170359-3)	AMP
	CLAMP	DELTA (34703237XX)	DELTA
DRIVE SIDE	PLUG	3M 10120-3000PE	3M
	SHELL	3M 10320-52A0-008	3M

Delta Part Number: **ASD-CAEN1000**

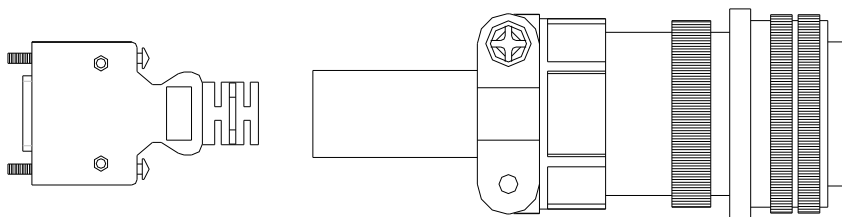

Title		Part No.	Manufacturer
MOTOR SIDE		3106A-20-29S	-
DRIVE SIDE	PLUG	3M 10120-3000PE	3M
	SHELL	3M 10320-52A0-008	3M

Encoder Cable (Incremental type)

Delta Part Number: **ASD-ABEN0003, ASD-ABEN0005**

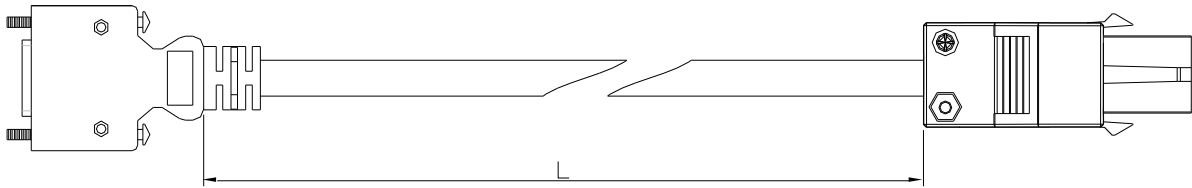

Title		Part No.	Manufacturer
MOTOR SIDE	Housing	AMP (1-172161-9)	AMP
	Terminal	AMP (170359-3)	AMP
	CLAMP	DELTA (34703237XX)	DELTA
DRIVE SIDE	PLUG	3M 10120-3000PE	3M
	SHELL	3M 10320-52A0-008	3M

Title	Part No.	L	
		mm	inch
1	ASD-ABEN0003	3000 ± 100	118 ± 4
2	ASD-ABEN0005	5000 ± 100	197 ± 4

Delta Part Number: **ASD-CAEN1003, ASD-CAEN1005**

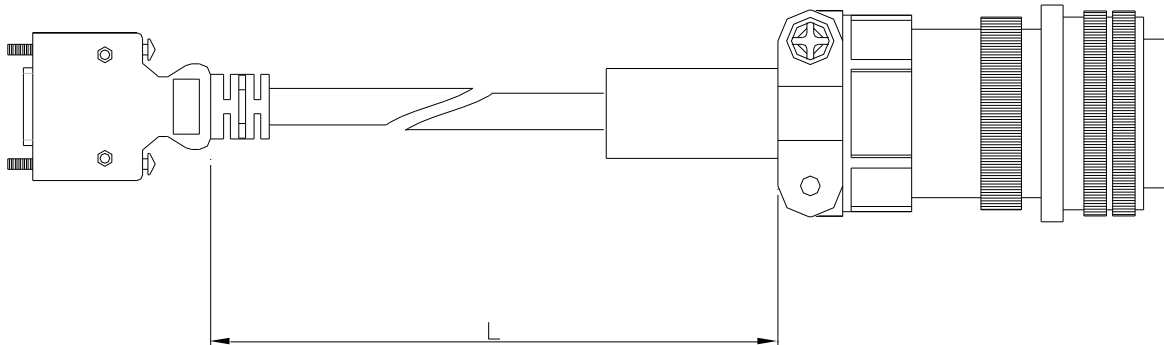

Title		Part No.	Manufacturer
MOTOR SIDE		3106A-20-29S	-
DRIVE SIDE	PLUG	3M 10120-3000PE	3M
	SHELL	3M 10320-52A0-008	3M

Title	Part No.	Straight	L	
			mm	inch
1	ASD-CAEN1003	3106A-20-29S	3000 ± 100	118 ± 4
2	ASD-CAEN1005	3106A-20-29S	5000 ± 100	197 ± 4

Encoder Cable (Absolute type)

Delta Part Number: **ASD-A2EB0003, ASD-A2EB0005**

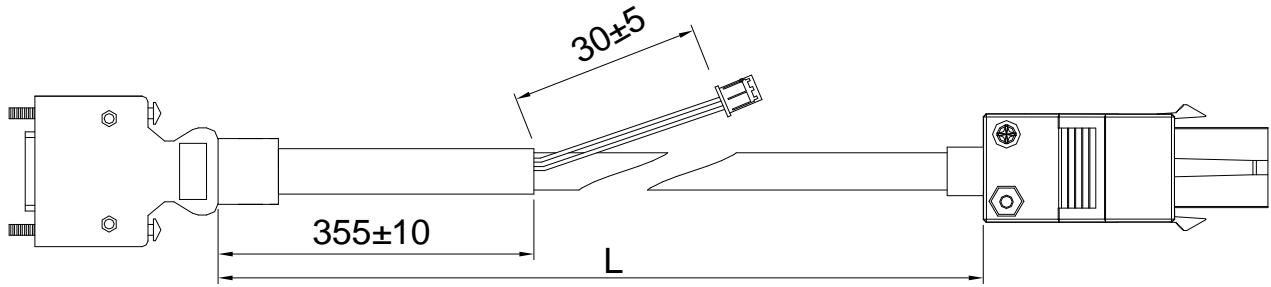

Title		Part No.	Manufacturer
MOTOR SIDE	Housing	AMP (1-172161-9)	AMP
	Terminal	AMP (170359-3)	AMP
	CLAMP	DELTA (34703237XX)	DELTA
DRIVE SIDE	PLUG	3M 10120-3000PE	3M
	SHELL	3M 10320-52A0-008	3M

Title	Model Name	L	
		mm	inch
1	ASD-A2EB0003	3000 ± 100	118 ± 4
2	ASD-A2EB0005	5000 ± 100	197 ± 4

Delta Part Number: **ASD-A2EB1003, ASD-A2EB1005**

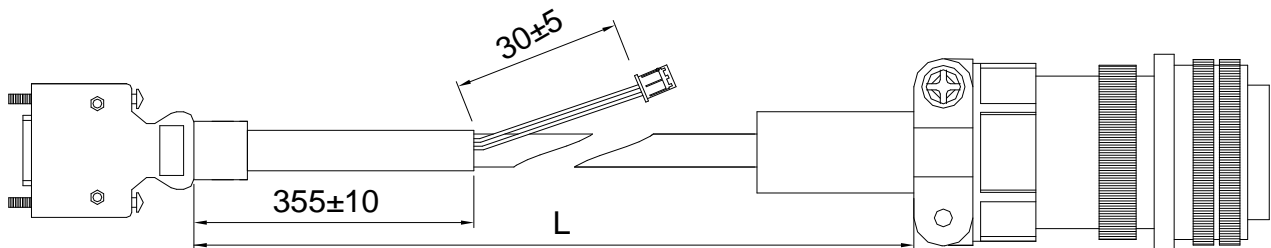

Title		Part No.	Manufacturer
MOTOR SIDE		3106A-20-29S	-
DRIVE SIDE	PLUG	3M 10120-3000PE	3M
	SHELL	3M 10320-52A0-008	3M

Title	Model Name	L	
		mm	inch
1	ASD-A2EB1003	3000 ± 100	118 ± 4
2	ASD-A2EB1005	5000 ± 100	197 ± 4

■ Signal Converter Box

Delta Part Number: **ASD-IF-EN0A20**

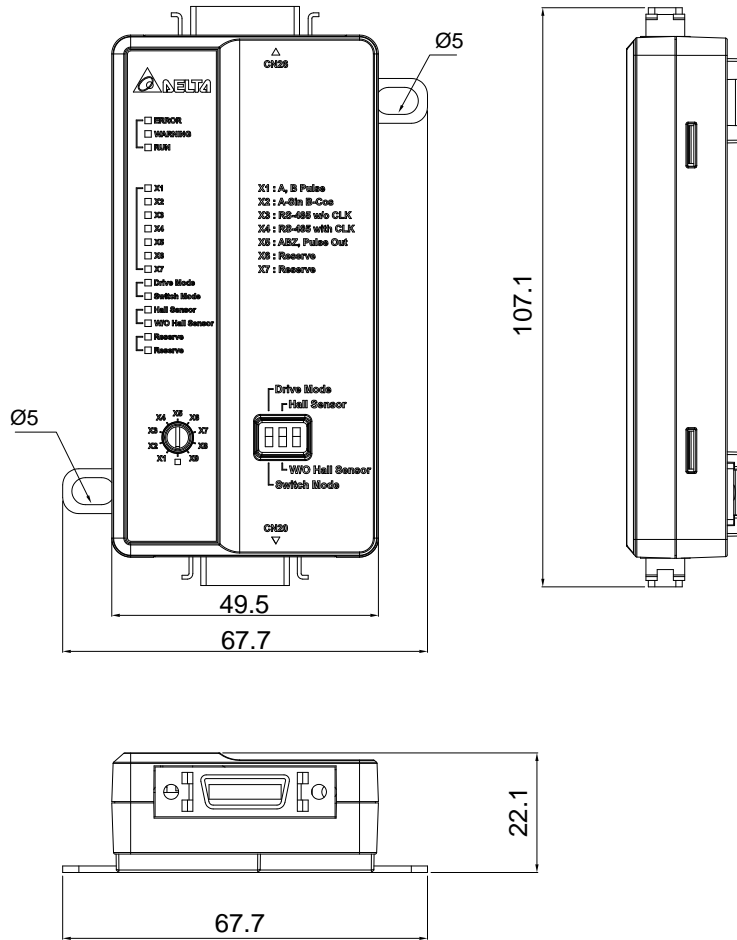

■ SCSI 26 pin Connector

Delta Part Number: **ASD-CN5C0026**

Title	Part No.	Vender Part No.	Manufacturer
Housing	305059030L	10326-52A0-008	3M
Terminal	307740120L	10126-3000PE	3M

■ SCSI 20 pin Connector

Delta Part Number: **ASD-CN5C0020**

Title	Part No.	Vender Part No.	Manufacturer
Housing	305059010L	10320-52A0-008	3M
Terminal	307740110L	10120-3000PE	3M

■ Signal Converter Box Cable

Delta Part Number: **ASD-CASC2003, ASD-CASC2005**

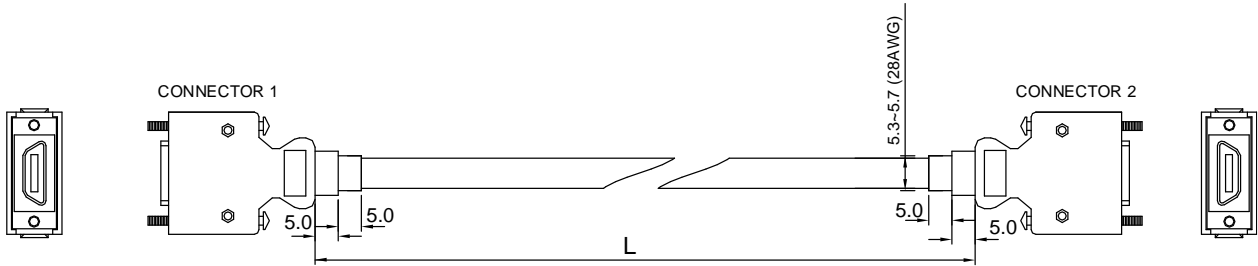

Title	Part No.	mm ² (AWG)	Type	L	
				mm	inch
1	ASD-CASC2003	5.3~5.7(28AWG)	UL2464	3000 ± 100	118 ± 4
2	ASD-CASC2005	5.3~5.7(28AWG)	UL2464	5000 ± 100	197 ± 4

■ I/O Connector

Delta Part Number: **ASD-CN5C0050**

Vendor Name	Vendor P/N
3M TAIWAN LTD	10150-3000PE
3M TAIWAN LTD	10350-52A0-008

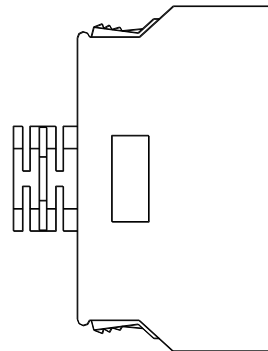

■ Terminal Block Module

Delta Part Number: **ASD-BM-50A**

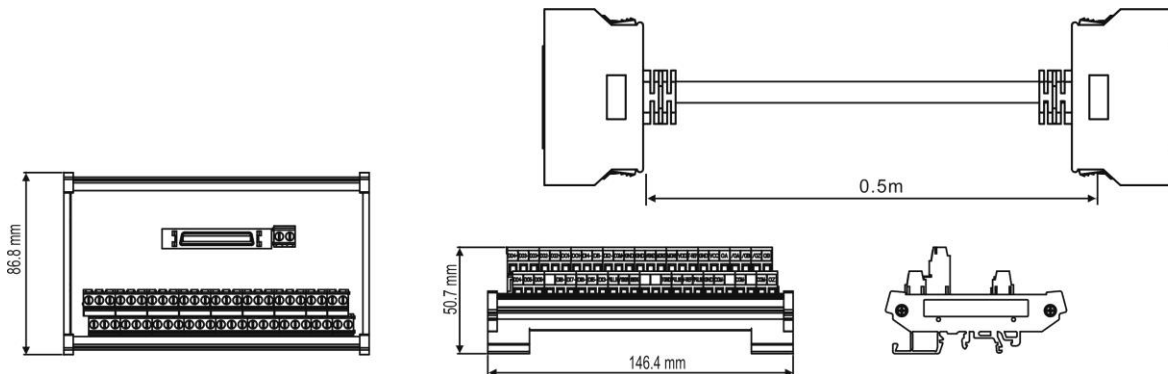

■ Software Communication Cable

Delta Part Number: **DOP-CAUSBAB**

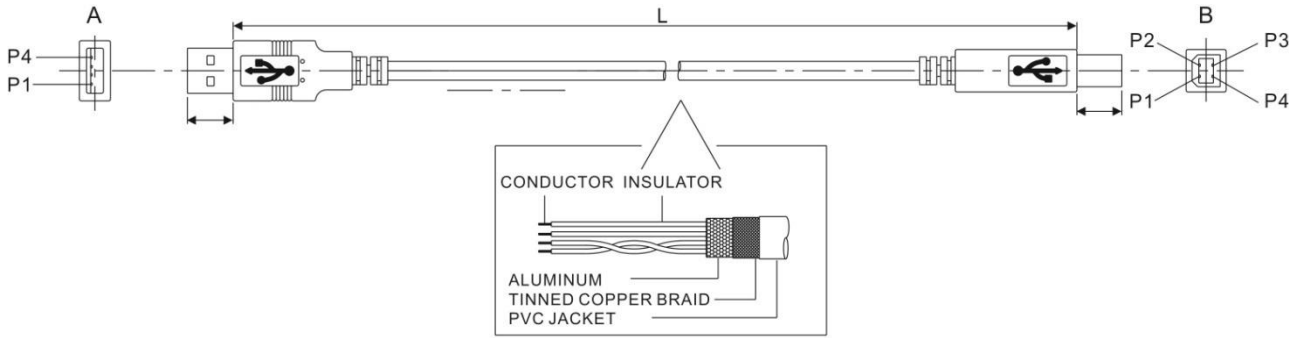

Title	Part No.	L	
		mm	inch
1	DOP-CAUSBAB	1400 ± 30	55 ± 1.2

■ CANopen Communication Cable

Delta Part Number: **TAP-CB03, TAP-CB04**

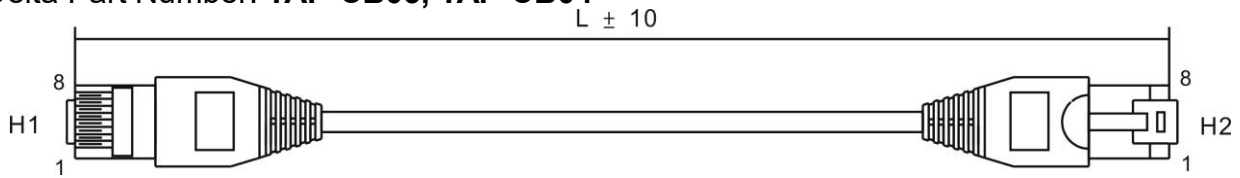

Title	Part No.	L	
		mm	inch
1	TAP-CB03	500 ± 10	19 ± 0.4
2	TAP-CB04	1000 ± 10	39 ± 0.4

■ CANopen Distribution Box

Delta Part Number: **TAP-CN03**

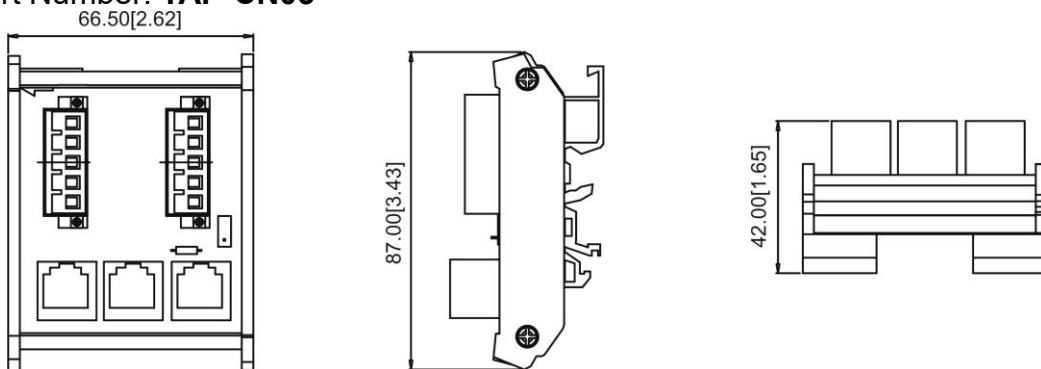

■ RS-485 Connector

Delta Part Number: **ASD-CNIE0B06**

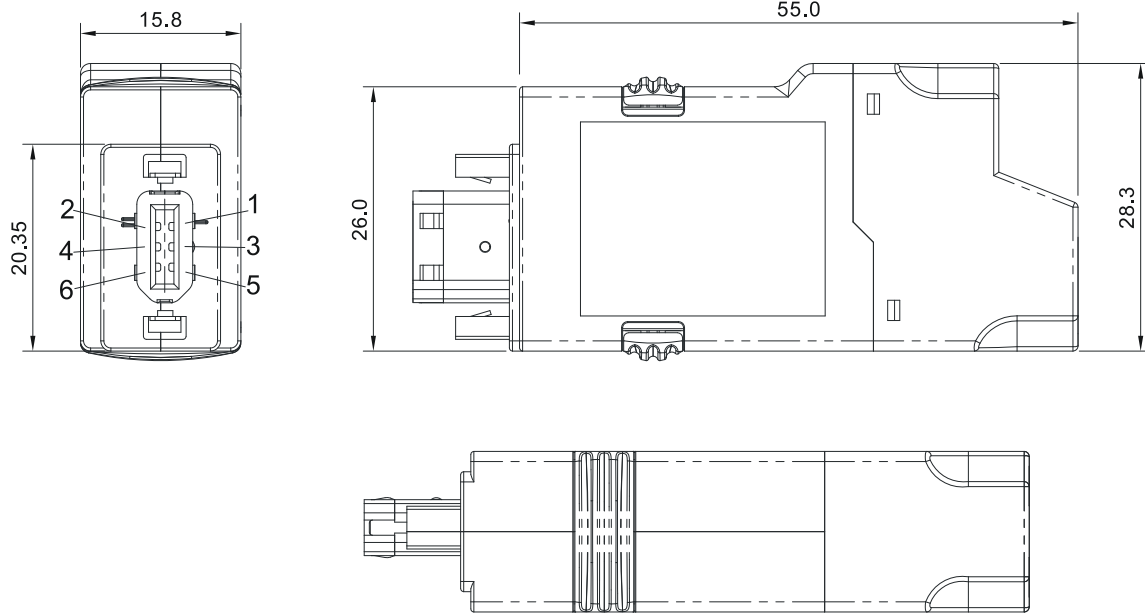

■ CN1 Quick Connector

Delta Part Number: **ASD-IF-SC5020**

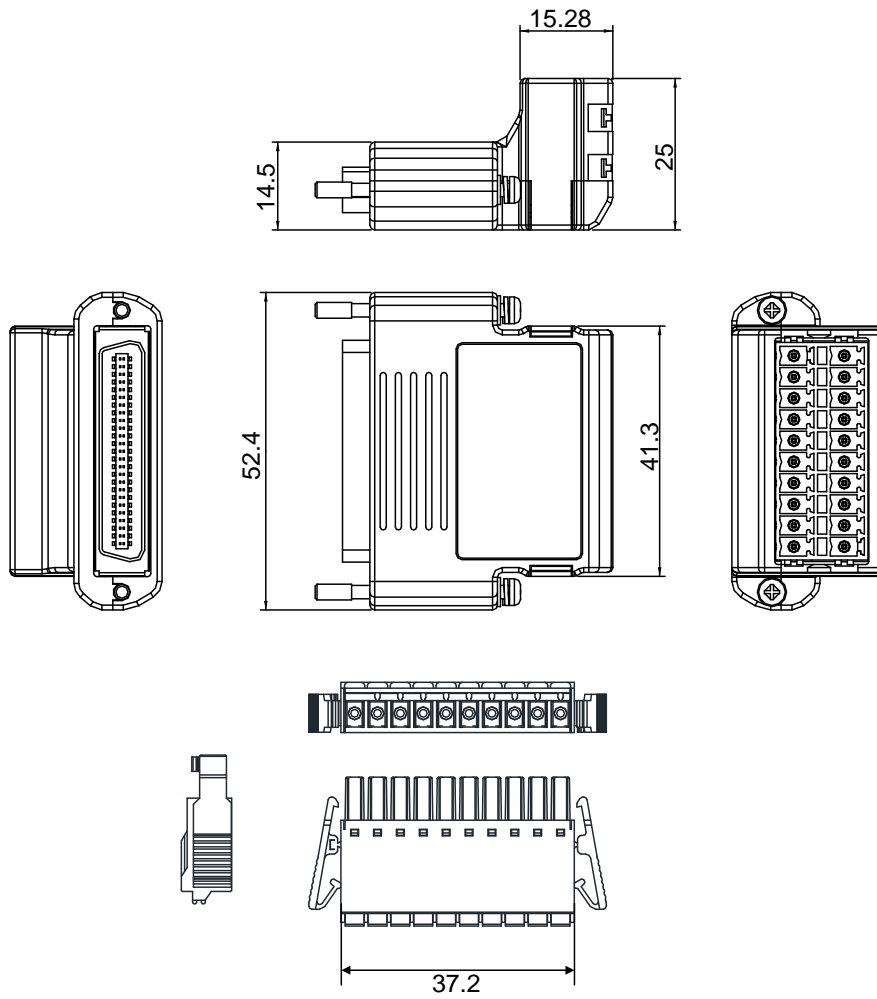

■ Optional Accessories

100W servo drive and 50W low-inertia motor

Servo Drive	ASD-A2R-0121-□
Low-inertia Motor	ECMA-C1040F□S
Motor Power Cable (without brake)	ASD-ABPW000X
Power Connector (without brake)	ASDBCAPW0000
Motor Power Cable (with brake)	ASD-ABPW010X
Power Connector (with brake)	ASDBCAPW0100
Incremental Type Encoder Connector	ASD-ABEN000X
Absolute Type Encoder Connector	ASD-A2EB000X
Encoder Connector	ASD-ABEN0000

(X=3 indicates that the cable length is 3m; X=5 indicates that the cable length is 5m)

100W servo drive and 100W low-inertia Motor

Servo Drive	ASD-A2R-0121-□
Low-inertia Motor	ECMA-C△0401□S
Motor Power Cable (without brake)	ASD-ABPW000X
Power Connector (without brake)	ASDBCAPW0000
Motor Power Cable (with brake)	ASD-ABPW010X
Power Connector (with brake)	ASDBCAPW0100
Incremental Type Encoder Connector	ASD-ABEN000X
Absolute Type Encoder Connector	ASD-A2EB000X
Encoder Connector	ASD-ABEN0000

(X=3 indicates that the cable length is 3m; X=5 indicates that the cable length is 5m)

200W servo drive and 200W low-inertia Motor

Servo Drive	ASD-A2R-0221-□
Low-inertia Motor	ECMA-C△0602□S
Motor Power Cable (without brake)	ASD-ABPW000X
Power Connector (without brake)	ASDBCAPW0000
Motor Power Cable (with brake)	ASD-ABPW010X
Power Connector (with brake)	ASDBCAPW0100
Incremental Type Encoder Connector	ASD-ABEN000X
Absolute Type Encoder Connector	ASD-A2EB000X
Encoder Connector	ASD-ABEN0000

(X=3 indicates that the cable length is 3m; X=5 indicates that the cable length is 5m)

400W servo drive and 400W low-inertia Motor

Servo Drive	ASD-A2R-0421-□
Low-inertia Motor	ECMA-C△0604□S ECMA-C△0804□7
Motor Power Cable (without brake)	ASD-ABPW000X
Power Connector (without brake)	ASDBCAPW0000
Motor Power Cable (with brake)	ASD-ABPW010X
Power Connector (with brake)	ASDBCAPW0100
Incremental Type Encoder Connector	ASD-ABEN000X
Absolute Type Encoder Connector	ASD-A2EB000X
Encoder Connector	ASD-ABEN0000

(X=3 indicates that the cable length is 3m; X=5 indicates that the cable length is 5m)

400W servo drive and 500W medium-inertia Motor

Servo Drive	ASD-A2R-0421-□
Medium-inertia Motor	ECMA-E△1305□S
Motor Power Cable (without brake)	ASD-CAPW100X
Motor Power Cable (with brake)	ASD-CAPW110X
Power Connector	ASD-CAPW1000
Incremental Type Encoder Connector	ASD-CAEN100X
Absolute Type Encoder Connector	ASD-A2EB100X
Encoder Connector	ASD-CAEN1000

(X=3 indicates that the cable length is 3m; X=5 indicates that the cable length is 5m)

400W servo drive and 300W high-inertia Motor

Servo Drive	ASD-A2R-0421-□
High-inertia Motor	ECMA-G△1303□S
Motor Power Cable (without brake)	ASD-CAPW100X
Motor Power Cable (with brake)	ASD-CAPW110X
Power Connector	ASD-CAPW1000
Incremental Type Encoder Connector	ASD-CAEN100X
Absolute Type Encoder Connector	ASD-A2EB100X
Encoder Connector	ASD-CAEN1000

(X=3 indicates that the cable length is 3m; X=5 indicates that the cable length is 5m)

750W servo drive and 500W high-inertia Motor

Servo Drive	ASD-A2R-0721-□
High-inertia Motor	ECMA-F11305□S
Motor Power Cable (without brake)	ASD-CAPW100X
Motor Power Cable (with brake)	ASD-CAPW110X
Power Connector	ASD-CAPW1000
Incremental Type Encoder Connector	ASD-CAEN100X
Absolute Type Encoder Connector	ASD-A2EB100X
Encoder Connector	ASD-CAEN1000

(X=3 indicates that the cable length is 3m; X=5 indicates that the cable length is 5m)

750W servo drive and 750W low-inertia Motor

Servo Drive	ASD-A2R-0721-□
Low-inertia Motor	ECMA-C△0807□S ECMA-C△0907□S
Motor Power Cable (without brake)	ASD-ABPW000X
Power Connector (without brake)	ASDBCAPW0000
Motor Power Cable (with brake)	ASD-ABPW010X
Power Connector (with brake)	ASDBCAPW0100
Incremental Type Encoder Connector	ASD-ABEN000X
Absolute Type Encoder Connector	ASD-A2EB000X
Encoder Connector	ASD-ABEN0000

(X=3 indicates that the cable length is 3m; X=5 indicates that the cable length is 5m)

750W servo drive and 600W high-inertia Motor

Servo Drive	ASD-A2R-0721-□
High-inertia Motor	ECMA-G△1306□S
Motor Power Cable (without brake)	ASD-CAPW100X
Motor Power Cable (with brake)	ASD-CAPW110X
Power Connector	ASD-CAPW1000
Incremental Type Encoder Connector	ASD-CAEN100X
Absolute Type Encoder Connector	ASD-A2EB100X
Encoder Connector	ASD-CAEN1000

(X=3 indicates that the cable length is 3m; X=5 indicates that the cable length is 5m)

1kW servo drive and 1kW low-inertia Motor

Servo Drive	ASD-A2R-1021-□
Low-inertia Motor	ECMA-C△1010□S
Motor Power Cable (without brake)	ASD-CAPW100X
Motor Power Cable (with brake)	ASD-CAPW110X
Power Connector	ASD-CAPW1000
Incremental Type Encoder Connector	ASD-CAEN100X
Absolute Type Encoder Connector	ASD-A2EB100X
Encoder Connector	ASD-CAEN1000

(X=3 indicates that the cable length is 3m; X=5 indicates that the cable length is 5m)

1kW servo drive and 1kW low-inertia Motor

Servo Drive	ASD-A2R-1021-□
Low-inertia Motor	ECMA-C△0910□S
Motor Power Cable (without brake)	ASD-ABPW000X
Power Connector (without brake)	ASDBCAPW0000
Motor Power Cable (with brake)	ASD-ABPW010X
Power Connector (with brake)	ASDBCAPW0100
Incremental Type Encoder Connector	ASD-ABEN000X
Absolute Type Encoder Connector	ASD-A2EB000X
Encoder Connector	ASD-ABEN0000

(X=3 indicates that the cable length is 3m; X=5 indicates that the cable length is 5m)

1kW servo drive and 1kW medium-inertia Motor

Servo Drive	ASD-A2R-1021-□
Medium-inertia Motor	ECMA-E△1310□S
Motor Power Cable (without brake)	ASD-CAPW100X
Motor Power Cable (with brake)	ASD-CAPW110X
Power Connector	ASD-CAPW1000
Incremental Type Encoder Connector	ASD-CAEN100X
Absolute Type Encoder Connector	ASD-A2EB100X
Encoder Connector	ASD-CAEN1000

(X=3 indicates that the cable length is 3m; X=5 indicates that the cable length is 5m)

1kW servo drive and 850W medium-high-inertia Motor

Servo Drive	ASD-A2R-1021-□
High-inertia Motor	ECMA-F△1308□S
Motor Power Cable (without brake)	ASD-CAPW100X
Motor Power Cable (with brake)	ASD-CAPW110X
Power Connector	ASD-CAPW1000
Incremental Type Encoder Connector	ASD-CAEN100X
Absolute Type Encoder Connector	ASD-A2EB100X
Encoder Connector	ASD-CAEN1000

(X=3 indicates that the cable length is 3m; X=5 indicates that the cable length is 5m)

1kW servo drive and 900W high-inertia Motor

Servo Drive	ASD-A2R-1021-□
High-inertia Motor	ECMA-G△1309□S
Motor Power Cable (without brake)	ASD-CAPW100X
Motor Power Cable (with brake)	ASD-CAPW110X
Power Connector	ASD-CAPW1000
Incremental Type Encoder Connector	ASD-CAEN100X
Absolute Type Encoder Connector	ASD-A2EB100X
Encoder Connector	ASD-CAEN1000

(X=3 indicates that the cable length is 3m; X=5 indicates that the cable length is 5m)

1.5kW servo drive and 1.5kW medium-inertia Motor

Servo Drive	ASD-A2R-1521-□
Medium-inertia Motor	ECMA-E△1315□S
Motor Power Cable (without brake)	ASD-CAPW100X
Motor Power Cable (with brake)	ASD-CAPW110X
Power Connector	ASD-CAPW1000
Incremental Type Encoder Connector	ASD-CAEN100X
Absolute Type Encoder Connector	ASD-A2EB100X
Encoder Connector	ASD-CAEN1000

(X=3 indicates that the cable length is 3m; X=5 indicates that the cable length is 5m)

2kW servo drive and 2kW low-inertia Motor

Servo Drive	ASD-A2R-2023-□
Low-inertia Motor	ECMA-C△1020□S
Motor Power Cable (without brake)	ASD-A2PW100X
Motor Power Cable (with brake)	ASD-A2PW110X
Power Connector	ASD-CAPW1000
Incremental Type Encoder Connector	ASD-CAEN100X
Absolute Type Encoder Connector	ASD-A2EB100X
Encoder Connector	ASD-CAEN1000

(X=3 indicates that the cable length is 3m; X=5 indicates that the cable length is 5m)

2kW servo drive and 2kW medium-inertia Motor

Servo Drive	ASD-A2R-2023-□
Medium-inertia Motor	ECMA-E△1320□S
Motor Power Cable (without brake)	ASD-A2PW100X
Motor Power Cable (with brake)	ASD-A2PW110X
Power Connector	ASD-CAPW1000
Incremental Type Encoder Connector	ASD-CAEN100X
Absolute Type Encoder Connector	ASD-A2EB100X
Encoder Connector	ASD-CAEN1000

(X=3 indicates that the cable length is 3m; X=5 indicates that the cable length is 5m)

2kW servo drive and 2kW medium-inertia Motor

Servo Drive	ASD-A2R-2023-□
Medium-inertia Motor	ECMA-E△1820□S
Motor Power Cable (without brake)	ASD-CAPW200X
Motor Power Cable (with brake)	ASD-CAPW210X
Power Connector	ASD-CAPW2000
Incremental Type Encoder Connector	ASD-CAEN100X
Absolute Type Encoder Connector	ASD-A2EB100X
Encoder Connector	ASD-CAEN1000

(X=3 indicates that the cable length is 3m; X=5 indicates that the cable length is 5m)

2kW servo drive and 1.3kW Medium-high-inertia Motor

Servo Drive	ASD-A2R-2023-□
Medium-high-inertia Motor	ECMA-F11313□S
Motor Power Cable (without brake)	ASD-A2PW100X
Motor Power Cable (with brake)	ASD-A2PW110X
Power Connector	ASD-CAPW1000
Incremental Type Encoder Connector	ASD-CAEN100X
Absolute Type Encoder Connector	ASD-A2EB100X
Encoder Connector	ASD-CAEN1000

(X=3 indicates that the cable length is 3m; X=5 indicates that the cable length is 5m)

2kW servo drive and 1.8kW Medium-high-inertia Motor

Servo Drive	ASD-A2R-2023-□
Medium-high-inertia Motor	ECMA-F11318□S
Motor Power Cable (without brake)	ASD-A2PW100X
Motor Power Cable (with brake)	ASD-A2PW110X
Power Connector	ASD-CAPW1000
Incremental Type Encoder Connector	ASD-CAEN100X
Absolute Type Encoder Connector	ASD-A2EB100X
Encoder Connector	ASD-CAEN1000

(X=3 indicates that the cable length is 3m; X=5 indicates that the cable length is 5m)

3kW servo drive and 3kW low-inertia Motor

Servo Drive	ASD-A2R-3023-□
Low-inertia Motor	ECMA-C△1330□4
Motor Power Cable (without brake)	ASD-A2PW100X
Motor Power Cable (with brake)	ASD-A2PW110X
Power Connector	ASD-CAPW1000
Incremental Type Encoder Connector	ASD-CAEN100X
Absolute Type Encoder Connector	ASD-A2EB100X
Encoder Connector	ASD-CAEN1000

(X=3 indicates that the cable length is 3m; X=5 indicates that the cable length is 5m)

3kW servo drive and 3kW medium-inertia Motor

Servo Drive	ASD-A2R-3023-□
Medium-inertia Motor	ECMA-E△1830□S
Motor Power Cable (without brake)	ASD-CAPW200X
Motor Power Cable (with brake)	ASD-CAPW210X
Power Connector	ASD-CAPW2000
Incremental Type Encoder Connector	ASD-CAEN100X
Absolute Type Encoder Connector	ASD-A2EB100X
Encoder Connector	ASD-CAEN1000

(X=3 indicates that the cable length is 3m; X=5 indicates that the cable length is 5m)

3kW servo drive and 3.5kW medium-inertia Motor

Servo Drive	ASD-A2R-3023-□
Medium-inertia Motor	ECMA-E△1835□S
Motor Power Cable (without brake)	ASD-CAPW200X
Motor Power Cable (with brake)	ASD-CAPW210X
Power Connector	ASD-CAPW2000
Incremental Type Encoder Connector	ASD-CAEN100X
Absolute Type Encoder Connector	ASD-A2EB100X
Encoder Connector	ASD-CAEN1000

(X=3 indicates that the cable length is 3m; X=5 indicates that the cable length is 5m)

3kW servo drive and 3kW Medium-high-inertia Motor

Servo Drive	ASD-A2R-3023-□
Medium-high-inertia Motor	ECMA-F△1830□S
Motor Power Cable (without brake)	ASD-CAPW200X
Motor Power Cable (with brake)	ASD-CAPW210X
Power Connector	ASD-CAPW2000
Incremental Type Encoder Connector	ASD-CAEN100X
Absolute Type Encoder Connector	ASD-A2EB100X
Encoder Connector	ASD-CAEN1000

(X=3 indicates that the cable length is 3m; X=5 indicates that the cable length is 5m)

Other Accessories (suitable for the whole series of ASDA-A2R)	
Name	Product Number
50 Pin I/O Connector (CN1)	ASD-CN5C0050
Terminal Block Module	ASD-BM-50A
Software Communication Cable	DOP-CAUSBAB
CANopen Communication Cable	TAP-CB03 / TAP-CB04
CANopen Distribution Box	TAP-CN03
RS-485 Connector	ASD-CNIE0B06
Regenerative Resistor 400W 40Ω	BR400W040
Regenerative Resistor 1kW 20Ω	BR1K0W020
Regenerative Resistor 1.5kW 5Ω	BR1K5W005

(This page is intentionally left blank.)

Appendix B Maintenance and Inspection

Basic Inspection

Item	Content
General inspection	Periodically check if the screws of the servo drive, the connection between the motor shaft and the mechanical system as well as the connection of terminal block and mechanical system are securely tightened.
	The gap of the control chamber and the installation of the cooling fan should free from oil, water or metallic particles. Also, the servo drive shall free from the cutting power of the power drill.
	If the control chamber is installed in the site which contains harmful gas or full of dust, please be ensured the servo drive is free from the harmful gas and dust.
	When making encoder cable or wire rods, please be ensured the wiring is correct. Otherwise, the motor may have sudden unintended acceleration or be burned.
Inspection before operation (has not applied to the power yet)	To avoid the electric shock, the ground terminal of the servo drive should firmly connect to the ground terminal of the control chamber. If the wiring is needed, wait at least 10 minutes after disconnecting the drive from the main supply power, or discharge electricity by discharge device.
	The splicing parts of the wiring terminal should be isolated.
	Make sure the wiring is correct so as to avoid the damage or any abnormality.
	Check if the electric conductivity objects including sheet metal (such as screws) or inflammable objects are not inside the servo drive.
	Check if the control switch is in OFF status.
	Do not place the servo drive of external regenerative resistor on inflammable objects.
	To avoid the electromagnetic brake losing efficacy, please check if stop function and circuit break function can work normally.
	If the peripheral devices are interfered by the electronic instruments, please reduce electromagnetic interference with devices.
Inspection before running the servo drive	The encoder cable should avoid excessive stress. When the motor is running, please be ensured the cable is not frayed or over extended.
	Please contact with Delta if there is any vibration of the servo motor or unusual noise during the operation.

(has already applied to the power)	Make sure the setting of the parameters is correct. Different machinery has different characteristic, please adjust the parameter according to the characteristic of each machinery.
	Please reset the parameter when the servo drive is in the status of SERVO OFF, or it may cause malfunction.
	When the relay is operating, make sure it can work properly.
	Check if the power indicator and LED display works normally.

Maintenance

- Please use and store the product in a proper site.
- Periodically clean the surface of the servo drive and servo motor so as to avoid the dust and dirt.
- Do not disassemble any mechanical part when in maintenance.
- Periodically clean the ventilation ports of the servo drive and do not use the product in a high-temperature site for a long time so as to avoid the malfunction.

The lifetime of machinery parts

- Dc Bus Capacitor
DC Bus Capacitor will be deteriorated by the affection of ripple current. Its lifetime is determined by the surrounding temperature and operating conditions. If it is operating in an air-conditioned site, its lifetime can up to 10 years.
- Relay
The contact of switching power supply will wear and leads to poor contact. The lifetime of relay is influenced by the power supply capacity; thus, the accumulative time of switching power supply is about 100,000 times.
- Cooling Fan
In continuous operation, the lifetime of the cooling fan is 2 to 3 years. However, if there is any unusual noise or vibration during inspection, place a new one is a must.