



Digitized Automation for a Changing World

# Delta Controller with Human Machine Interface HMC Series



[www.deltaww.com](http://www.deltaww.com)

 **DELTA**  
Smarter. Greener. Together.

# High Quality Display, Precise Control: The Optimum Combination of Display and Controller

## Standard Type HMC08



Manual Pulse Generator (MPG)



64K Colors TFT



DMCNET

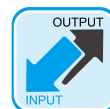

Digital I/O

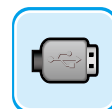

USB Disk

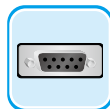

DMCNET

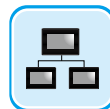

Ethernet



SD Card

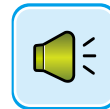

Audio Output

## Handheld Type HMC07-N412H5CX

New



Manual Pulse Generator (MPG)



64K Colors TFT



DMCNET

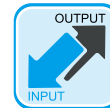

Digital I/O



Nameplate Protection



Emergency Stop



Compact Design

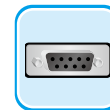

DMCNET



SD Card



Safety Limit Switch

## Handheld Type HMC07-N412H5CX



64K Colors TFT



DMCNET

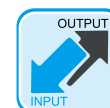

Digital I/O



Nameplate Protection



Emergency Stop



Compact Design

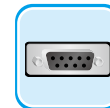

DMCNET



SD Card



**Handheld Type** HMC07-R412H5CX

New



MPG 手搖輪



64K Colors TFT



DMCNET

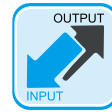

Digital I/O



行業專用輔助鍵



銘版防護



緊急停止按鈕



輕量化設計

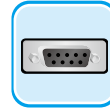

串列介面



SD 卡



限動開關

**Handheld Type** HMC07-R412H55X

New



64K Colors TFT



DMCNET

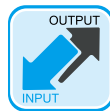

Digital I/O



行業專用輔助鍵



銘版防護



緊急停止按鈕



輕量化設計



串列介面



SD 卡





# Features

## DOPSoft for HMI Screen Editing and PLC Programming



### Powerful Dual Processors

Equipped with two high-speed CPUs: one for HMI operation, and the other as a Digital Signal Processor (DSP). The DSP serves as a motion processor for sequence control, which guarantees execution efficiency and system performance. The DSP supports up to four major PLC programs simultaneously.

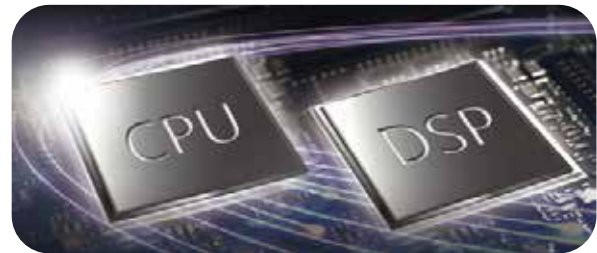

### Direct Remote I/O Connection



I/O points placed in the rear of the panel, result in complicated wiring and connection



Direct remote I/O connection provides simple and effortless wiring. Only one communication cable is needed to complete the I/O connection.

### Quick PLC Ladder Monitoring

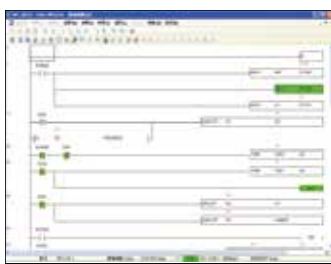

PLC ladder programs and registers can be monitored and changed in real time on a PC to greatly reduce the verification and debug time via Ethernet.

Ethernet



Built-in PLC ladder monitor devices allow users to display programs in real time and confirm machine operations without using a PC.

### Full nameplate protection enhances tolerance to various conditions

The new handheld models are equipped with full nameplate protection to prevent oil damage of the PCB and extend product life cycle.

### Built-in Motion Commands

Direct servo parameter setup and quick motion command editing, no additional communication commands are required.

# Solution Structure

## HMC R412 + ASDA-A3 Series

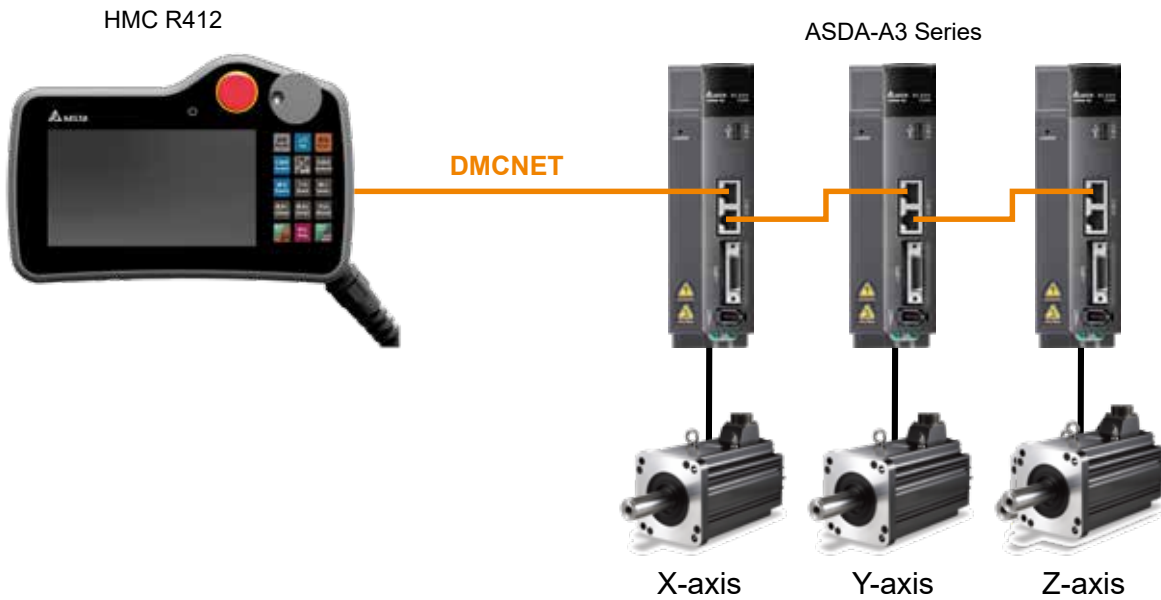

## Application

### Control of a Pick-an-Place Robot for an Injection Molding Machine

#### Features

1. The HMC integrates display and remote control functions with built-in PLC
2. High speed motion control bus for Delta Industrial PC-Based Motion Control Solution DMCNET
3. High speed remote I/O modules
4. Built-in ASD-specific motion control device



## Solution Structure

HMC + AC Servo Drive & Motor ASDA-M  
+ AC Servo Drive & Motor ASDA-A2

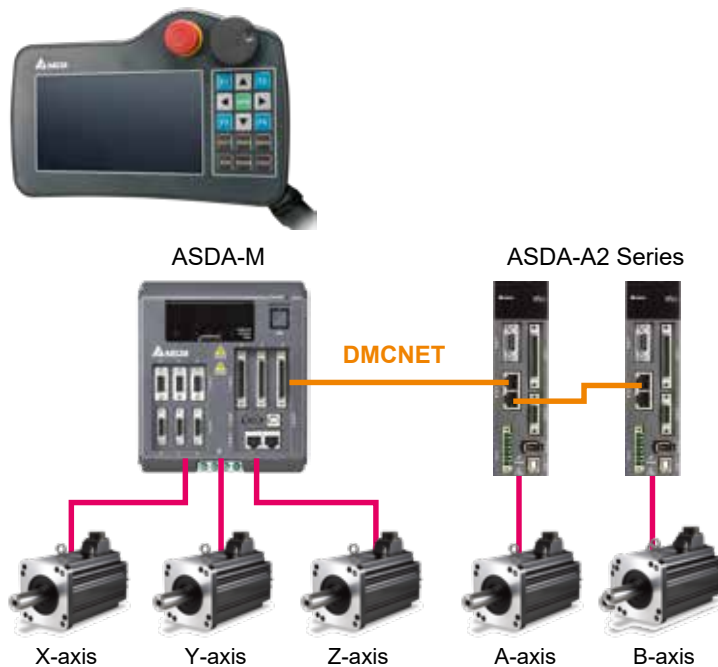

HMC + AC Servo Drive ASDA-B2  
+ E2M Motors



## Application

Robotic Loading/Unloading for Machine Tools

### Features

Distributed system bus supports various industry applications, large volume of program commands (1000 programs available, 400 editable items in each program) and dual system



# Application Cases for Quick Implementation

- ▶ System parameter settings: including gear ratio, acceleration/deceleration time and speed

**Servo Setting** | 1 | DEMO | 2015/10/19 | 14:31:34

	Gear ratio (Mot.)	Gear ratio (Don.)	S-curve	Acc. time (ms)	Dec. time (ms)	Homing acc./dec.	Max speed mm/s	RPM	Dir.
X1 axis	128	1	125	10	10	600	333.332	2000	C.W
Y1 axis	128	1	50	10	10	400	333.333	2000	C.W
Z1 axis	128	1	240	10	10	400	333.333	2000	C.C.W

X1 axis: 0.000 | Y1 axis: 0.000 | Z1 axis: 0.000

Operate | Manual | Teach | I/O | System | Alarm | Main

**Motion Setting** | 1 | DEMO | 2015/10/19 | 14:28:34

	Homing Offset (mm)	Homing Mode	Homing High speed (mm/s)	Homing Low speed (mm/s)	Autofan speed (mm/s)	Jog speed (mm/s)	Torque protection (%)
X1 axis	0.000	20	30.000	30.000	121.522	100.000	10.0
Y1 axis	0.000	25	50.000	50.000	150.000	100.000	10.0
Z1 axis	0.000	25	50.000	50.000	150.000	100.000	20.0

X1 axis: -0.001 | Y1 axis: 0.000 | Z1 axis: 0.000

Operate | Manual | Teach | I/O | System | Alarm | Main

- ▶ Intuitive teaching interface

**TEACH** | Motion Setting | 1 | DEMO | 2015/10/19 | 14:33:59

No. (Main Sys.) Instructions

- Goto T.P. ,speed:5% ,P1
- Goto T.P. ,speed:5% ,P2
- Output(Y)ON
- Goto T.P. ,speed:5% ,P1 ,delay:1.0 Sec

Speed: 50 %  
Delay before: 0.0 Sec

Teach Point: 1 | T.Point

Operate | Manual | Teach | I/O | System | Alarm | Main

- ▶ Positioning setting

**Main system Teach Point coordinate**

Comment	P	#X1 axis	#Y1 axis	#Z1 axis
Pos. 1	1	100.000	0.000	0.000
Pos. 2	2	0.000	100.000	0.000
Pos. 3	3	0.000	0.000	0.000
Pos. 4	4	0.000	0.000	0.000
Pos. 5	5	0.000	0.000	0.000
Pos. 6	6	0.000	0.000	0.000
Pos. 7	7	0.000	0.000	0.000
Pos. 8	8	0.000	0.000	0.000

Select T. Point: 1 | Write to Point | Read from Point

X1 axis: 0.000 | Y1 axis: 100.000 | Z1 axis: 0.000

Manual

- ▶ Operation program management

**PROGRAM MANAGE** | 1 | DEMO | 2015/10/19 | 14:33:17

No.	Program name	Modified time
1	DEMO	2015/10/19 10:58:49
2		
3	J1	2015/10/19 9:28:2
4		
5		
7	3D	2015/10/19 9:28:26
8	EDIT-TEST-2	2015/10/19 9:28:4
9	EDIT-TEST	2015/10/19 9:28:34
10	LD-UL-A	2015/10/19 11:0:11

X1 axis: -0.001 | Y1 axis: 0.001 | Z1 axis: 0.001

Operate | Manual | Teach | I/O | System | Alarm | Main

- ▶ Operation information

**AUTO** | Running Setting | 1 | DEMO | 2015/10/19 | 15:17:15

No. | T. Points | (Main Sys.) Instructions

- Goto T.P. ,speed:10% ,P1
- Goto T.P. ,speed:10% ,P2
- Output(Y)ON
- Goto T.P. ,speed:10% ,P1 ,delay:1.0 Sec

Speed: 50 %  
High Speed | Low Speed

Running Information

Planned cycles: 0  
Remainder: 0  
Cycle time: 0.00 Sec

Zero Return | Run | Pause | Stop | CycleStop | Magn: 1 | Hand Wheel

X1 axis: 59.825 | Y1 axis: 0.000 | Z1 axis: 0.000

Operate | Manual | Teach | I/O | System | Alarm | Main



# Application Cases for Quick Implementation

## ▶ Abundant operating instructions

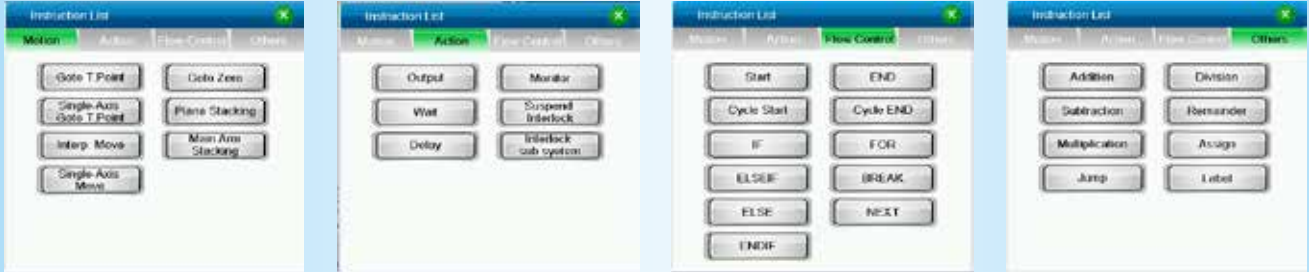

## ▶ Jog function



## ▶ Security zone setting

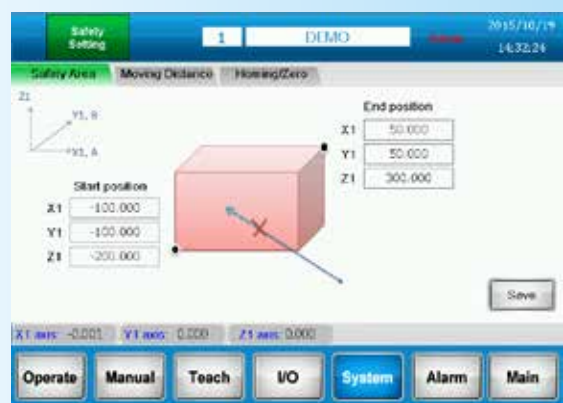

## ▶ Various stacking instructions

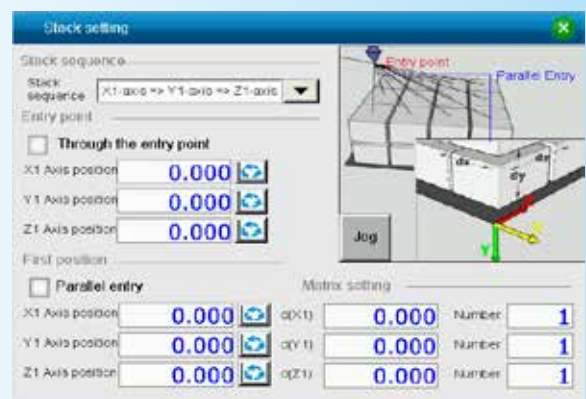
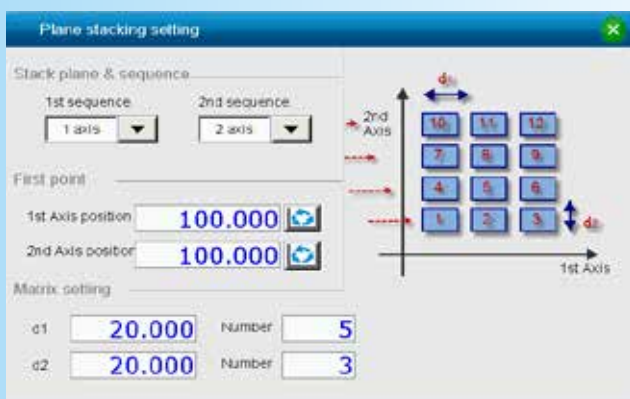



# Complete Total Solution

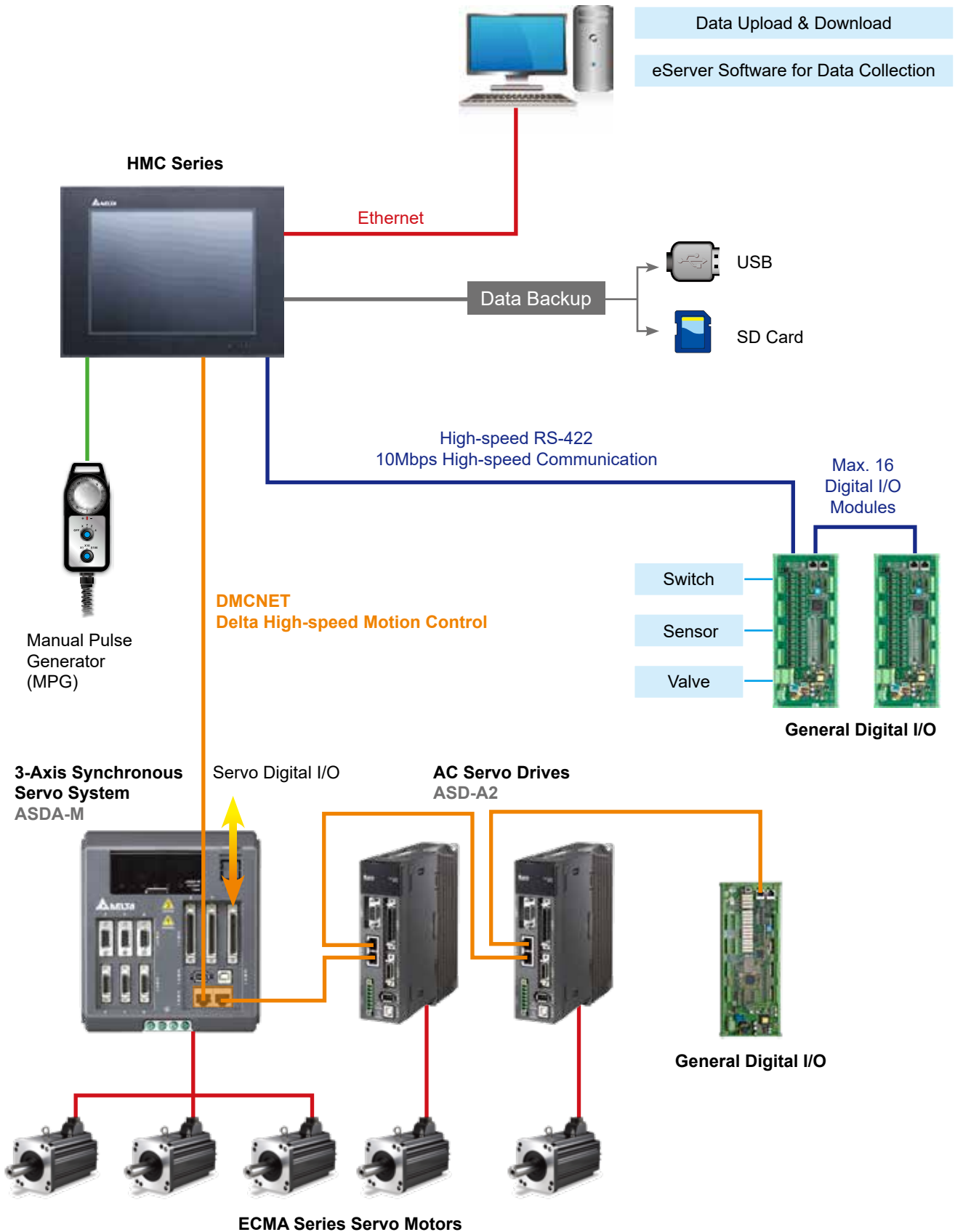

# Dimensions Dimensions are in mm (in.)

**NEW**

**Model Name** HMC07-N412 Series  
HMC07-R412 Series

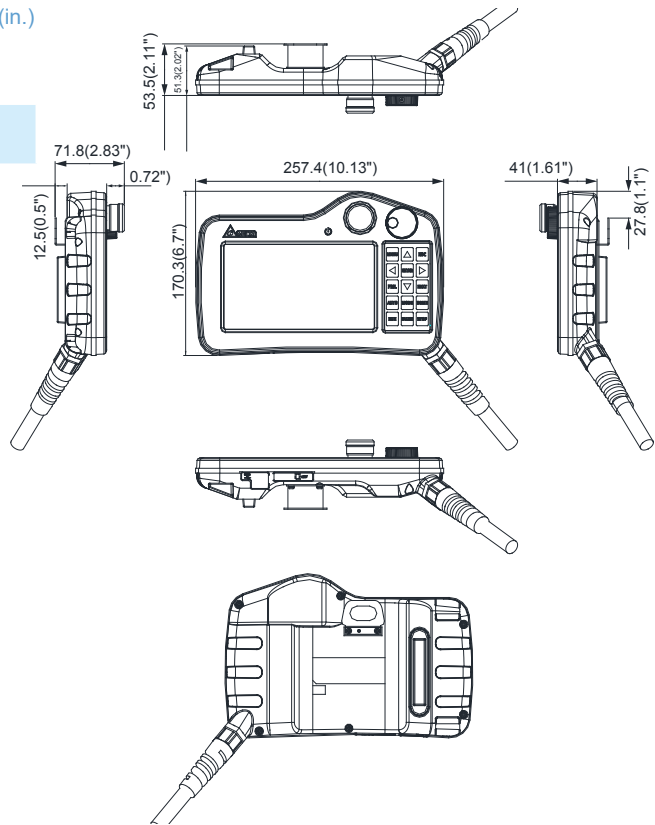

**Model Name** HMC08-N5xx Series

**Model Name** Remote I/O Module

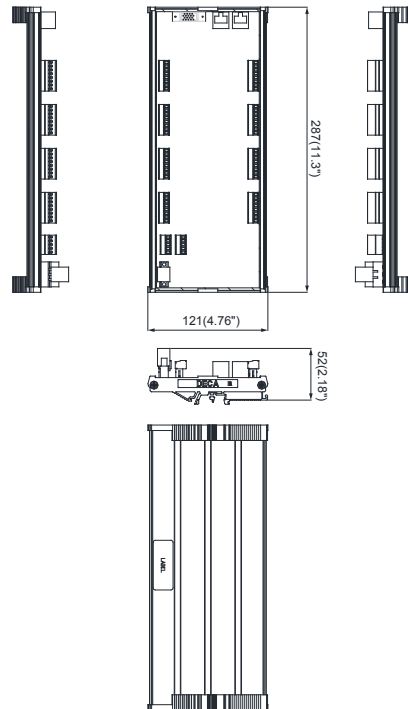
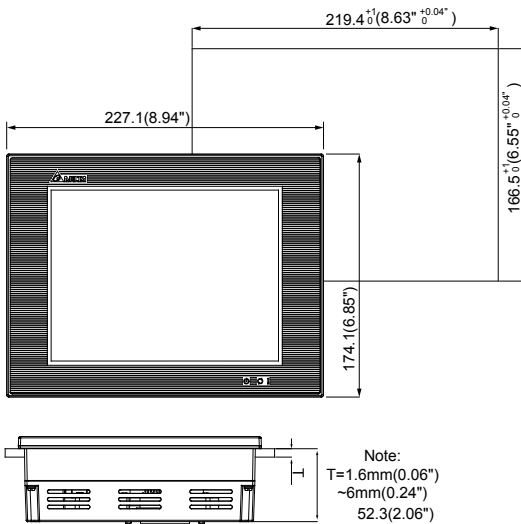

# Specifications

Model		HMC07-N412H5CX HMC07-R412H5CX	HMC07-N412H55X HMC07-R412H55X	HMC08-N500S52
LCD Module	Display Type	7" TFT LCD		8" TFT LCD
	Colors	65535		
	Resolution (pixels)	800 x 480	800 x 600	
	Backlight	LED back light (Half-life > 20k hours in 25°C environment) <sup>1)</sup>		
	Display Size (mm)	154.08 x 85.92	162 x 121.5	
Axes of Control		Max. 12 axes		
Operating System		Delta Real Time OS		
CPU	HMI	32-bit RISC Micro-controller		
	Controller	32-bit DSP		
Flash ROM (Bytes)		Flash ROM 128 MB (OS System: 30 MB / Backup: 16 MB / User Application: 82 MB)		
Backup Memory (Bytes)		16 MB ROM, 128 KB SRAM		
Buzzer		Multi-Tone Frequency (2K ~ 4 KHz) / 85 dB		
Communication Networks	Ethernet	N/A		1
	Social COM Port	RS-485 (Built-in power isolation <sup>2)</sup> )		RS-232 / RS-422 / RS-485 <sup>2)</sup>
	Motion Control BUS	DMCNET		
	USB	1 USB Slave Ver 2.0		1 USB Host Ver 1.1 / 1 USB Slave Ver 2.0
SD		SD / SDHC		
Emergency Stop Switch		Push-lock switch Output: 2 contacts B-contact (normally closed) x 2 Rated voltage: DC 30V Max. rated current: 500 mA Min. load allowed: 5VDC / 1 mA		N/A
3-Position Operation Switch		Only for internal register, no output signal	N/A	N/A
Manual Pulse Generator (MPG)		Only for internal register, no output signal	N/A	N/A
function Key		15		N/A
Cable Length		The X in HMC model name indicates cable length <sup>3)</sup>		N/A
Perpetual Calendar		Built-in		
Cooling Method		Natural cooling		
Safety Certification		CE		CE / UL
Protection Rating		IP54		IP65
Voltage		DC + 24V <sub>DC</sub> (± 15%) <sup>4)</sup> (Supplied by SELV circuits isolated from MAINS by double insulation)		
Voltage Endurance		Between DC24 terminal and FG terminal: AC500V, 1 min		
Power Consumption		6W <sup>5)</sup>		11W
Backup Battery		3V lithium CR2450 × 1		3V lithium CR2032 × 1
Backup Battery Life		5 years or more at 25°C, may vary due to temperature and usage condition		
Operation Temperature		0°C ~ 40°C		0°C ~ 50°C
Storage Temperature		-10°C ~ 60°C		
Operation Environment		10% ~ 90% RH (0 ~ 40°C), 10% ~ 55% RH (41 ~ 50°C), Pollution Degree 2		
Vibration		IEC61131-2 compliant 5 Hz ~ 8.3 Hz 3.5 mm, 8.3 Hz ~ 150 Hz 1G		
Shock		IEC60068-2-27 compliant 11 ms, 15G Peak, X, Y, Z direction for 6 times		
Dimensions (W) x (H) x (D) mm		257.4 x 170.3 x 71.8 (Emergency stop button and hook included)		219.4 x 174.1 x 52.3
Weight		750 g (Wire excluded)		about 1314 g

Note:

- 1) The half-life of the backlight is defined as the original luminance being reduced by 50% when the maximum driving current is supplied to the HMI
- 2) The isolated power circuit can withstand a 1500 V for 1 minute.
- 3) X = 5 : 5m, X = A : 10m, X = F : 15m, X = K : 20m
- 4) Isolated power supply recommended
- 5) The value of the power consumption indicates the electrical power consumed by HMI with no peripheral devices connected. To ensure normal operation, it is recommended using a power supply with a capacity 1.5 ~ 2 times the value of the power consumption

## Model List

Model Name	Descriptions	Note
<b>HMC07-N412H5C5</b>	General handheld controller for standard truss with built-in MPG and safety limit switch, 5 m cable included	( Note 1 )
<b>HMC07-N412H5CA</b>	General handheld controller for standard truss with built-in MPG and safety limit switch, 10 m cable included	( Note 1 )
<b>HMC07-N412H5CF *</b>	General handheld controller for standard truss with built-in MPG and safety limit switch, 15 m cable included	( Note 1 ) ( Note 3 )
<b>HMC07-N412H5CK *</b>	General handheld controller for standard truss with built-in MPG and safety limit switch, 20 m cable included	( Note 1 ) ( Note 3 )
<b>HMC07-R412H5C5</b>	Handheld controller for injection machine pick-and-place with built-in MPG and safety limit switch, 5 m cable included	( Note 2 )
<b>HMC07-R412H5CA</b>	Handheld controller for injection machine pick-and-place with built-in MPG and safety limit switch, 10 m cable included	( Note 2 )
<b>HMC07-R412H555</b>	Handheld controller for injection machine pick-and-place without built-in MPG and safety limit switch, 5 m cable included	( Note 2 )
<b>HMC07-R412H55A *</b>	Handheld controller for injection machine pick-and-place without built-in MPG and safety limit switch, 10 m cable included	( Note 2 ) ( Note 3 )
<b>HMC08-N500S52</b>	Fix-mounted controller with human machine interface HMC08	
<b>HMC-RIO3232RT5</b>	DMCNET remote I/O module (16 pts relay output), 32IN / 32OUT	
<b>HMC-RIO3232T15</b>	DMCNET remote I/O module (all-transistor output), 32IN / 32OUT	
<b>HM-RIO3232T12</b>	RS-422 remote I/O module, 32IN / 32OUT (for HMC 08 only)	

\*\*Note:

1. The physical button is in English.
2. The physical button is in Simplified Chinese & English.
3. Please contact Delta regional sales for inquiry.  
(Please refer to the product images for different models)



## Electrical Specifications of Remote I/O Modules

Model Name	Power Supply	Input Unit		Output Unit	
		Points	Type	Points	Type
HM-RIO3232T12 (HMC08-N500 only)	24 V <sub>DC</sub>	32	NPN (Sink)	32	Transistor
Input Point Electrical Specifications				Output Point Electrical Specifications	
Input Impedance		4.7 kΩ		Max. Switching Frequency	
Max. Switching Frequency		100 kHz		500 kHz	
Active Level	Off → On	> 16.5 V <sub>DC</sub>		Response Time (Relay)	On → Off
	On → Off	< 5 V <sub>DC</sub>			On → Off
Response Time	Off → On	< 3 μs		-	
	On → Off	< 40 μs		-	

Model Name	Power Supply	Input Unit		Output Unit		
		Points	Type	Points	Type	
HMC-RIO3232RT5 (For all models)	24 V <sub>DC</sub>	32	NPN (Sink)/ PNP (Source)	16 Relay / 16 TR	Relay/Transistor	
Input Point Electrical Specifications				Output Point Electrical Specifications		
Input Impedance		4.7 kΩ		Max. Switching Frequency		
Max. Switching Frequency		10 kHz		1 Hz (Relay) 8 kHz (TR)		
Active Level	Off → On	> 16.5 V <sub>DC</sub>		Response Time (Relay)	300 mA / 1 Point (TR) 2A / 1 Point (Relay)	
	On → Off	< 5 V <sub>DC</sub>			Off → On	10 ms
-				Response Time (TR)	Off → On	12 μs
-					On → Off	115 μs

Model Name	Power Supply	Input Unit		Output Unit		
		Points	Type	Points	Type	
HMC-RIO3232T15 (For all models)	24 V <sub>DC</sub>	32	NPN (Sink)/ PNP (Source)	32	Transistor	
Input Point Electrical Specifications				Output Point Electrical Specifications		
Input Impedance		4.7 kΩ		Max. Switching Frequency		
Active Level		> 16.5 V <sub>DC</sub>		8 kHz (TR)		
Active Level	Off → On	> 16.5 V <sub>DC</sub>		Maximum Loading	Resistive Load	
	On → Off	< 5 V <sub>DC</sub>				2A / 1 Point
-				Response Time (TR)	Off → On	12 μs
-					On → Off	115 μs

# Model Introduction

## HMC Series

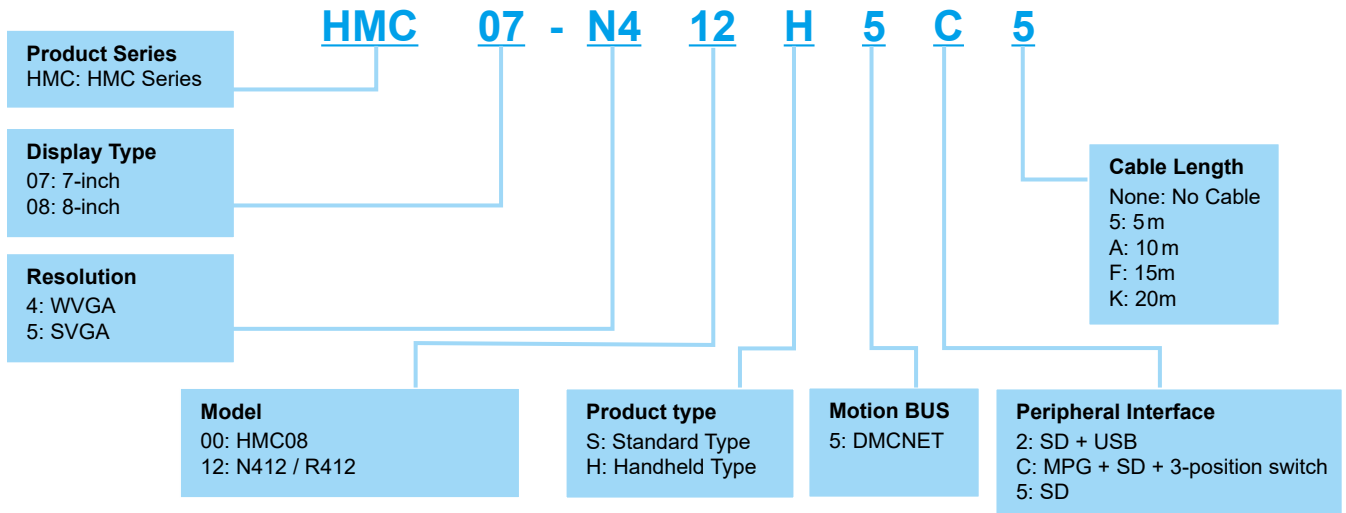

## Servo Motors ECMA Series

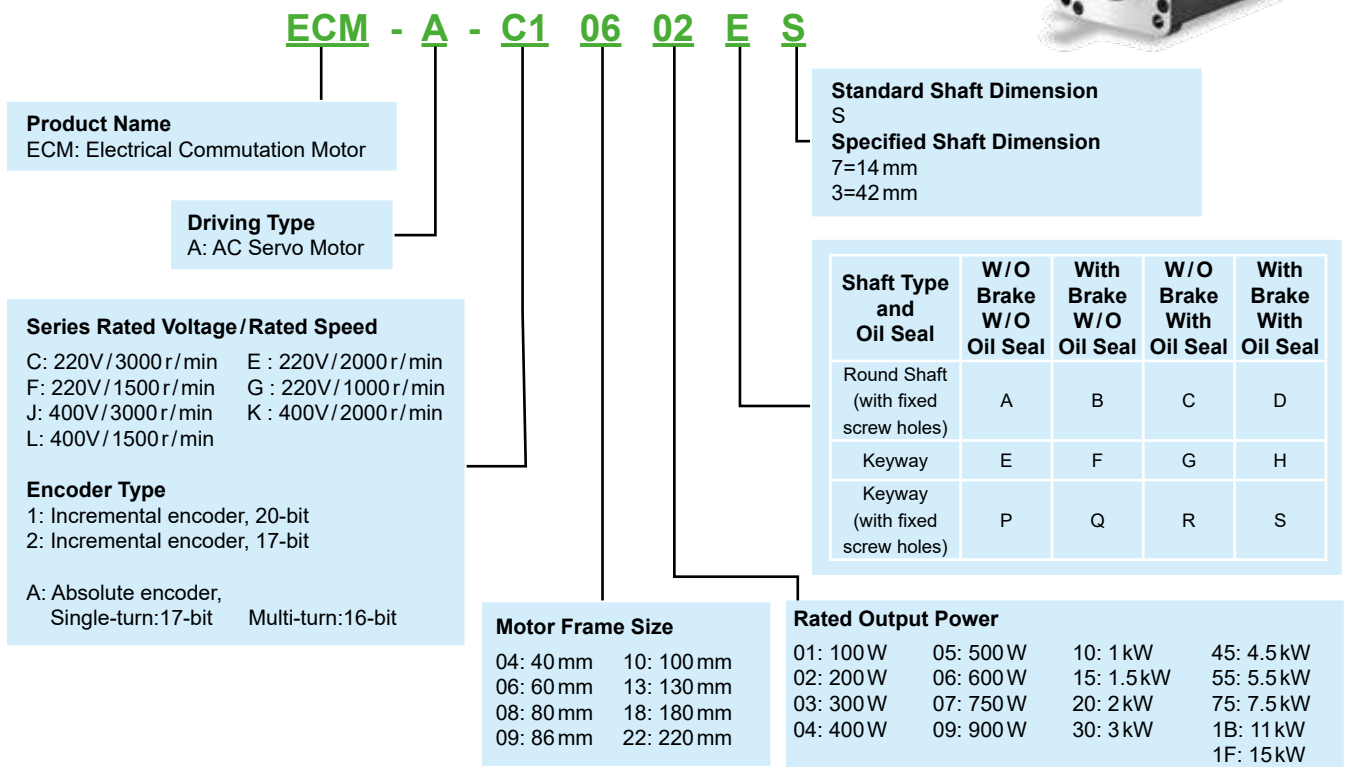

## Servo Drives ASDA-M Series



**ASD - M - 07 21 - F**

Product Name: AC Servo Drive

Series: M

F: DMCNET

Input Voltage and Phase  
21: 220V 1-phase  
23: 220V 3-phase

Rated Output Power  
07: 750 W  
15: 1.5 kW

## Servo Drives ASDA-A2 Series



**ASD - A2 - 04 21 - F**

Product Name: AC Servo Drive

Series: A2

F: DMCNET

Input Voltage and Phase  
21: 220V 1-phase/3-phase  
23: 220V 3-phase  
43: 400V 3-phase

Rated Output Power  
01: 100 W    20: 2.0 kW  
02: 200 W    30: 3.0 kW  
04: 400 W    45: 4.5 kW  
07: 750 W    55: 5.5 kW  
10: 1.0 kW    75: 7.5 kW  
15: 1.5 kW    1B: 11 kW  
                  1F: 15 kW

## Optional Accessories

Model Name	Model Name
HMC-CA3205C0	Handheld types HMC07-N5xx Series connection cable (5m, 32-pin)
HMC-CA3210C0	Handheld types HMC07-N5xx Series connection cable (10m, 32-pin)
HMC-CA1205C0	Handheld types HMC07-N5xx Series connection cable (5m, 12-pin)
HMC-CA1210C0	Handheld types HMC07-N5xx Series connection cable (10m, 32-pin)
NC-CAB-DMC003	DMCNET/Remote I/O connection cable (0.3m)
NC-CAB-DMC015	DMCNET/Remote I/O connection cable (1.5m)
NC-CAB-DMC050	DMCNET/Remote I/O connection cable (5m)
NC-CAB-DMC100	DMCNET/Remote I/O connection cable (10m)



Smarter. Greener. Together.

## Industrial Automation Headquarters

### Taiwan: Delta Electronics, Inc.

Taoyuan Technology Center  
No.18, Xinglong Rd., Taoyuan District,  
Taoyuan City 33068, Taiwan  
TEL: +886-3-362-6301 / FAX: +886-3-371-6301

## Asia

### China: Delta Electronics (Shanghai) Co., Ltd.

No.182 Minyu Rd., Pudong Shanghai, P.R.C.  
Post code : 201209  
TEL: +86-21-6872-3988 / FAX: +86-21-6872-3996  
Customer Service: 400-820-9595

### Japan: Delta Electronics (Japan), Inc.

Industrial Automation Sales Department  
2-1-14 Shibadaimon, Minato-ku  
Tokyo, Japan 105-0012  
TEL: +81-3-5733-1155 / FAX: +81-3-5733-1255

### Korea: Delta Electronics (Korea), Inc.

1511, 219, Gasan Digital 1-Ro., Geumcheon-gu,  
Seoul, 08501 South Korea  
TEL: +82-2-515-5305 / FAX: +82-2-515-5302

### Singapore: Delta Energy Systems (Singapore) Pte Ltd.

4 Kaki Bukit Avenue 1, #05-04, Singapore 417939  
TEL: +65-6747-5155 / FAX: +65-6744-9228

### India: Delta Electronics (India) Pvt. Ltd.

Plot No.43, Sector 35, HSIIDC Gurgaon,  
PIN 122001, Haryana, India  
TEL: +91-124-4874900 / FAX: +91-124-4874945

### Thailand: Delta Electronics (Thailand) PCL.

909 Soi 9, Moo 4, Bangpoo Industrial Estate (E.P.Z),  
Pattana 1 Rd., T.Phraksa, A.Muang,  
Samutprakarn 10280, Thailand  
TEL: +66-2709-2800 / FAX: +66-2709-2827

### Australia: Delta Electronics (Australia) Pty Ltd.

Unit 20-21/45 Normanby Rd., Notting Hill Vic 3168, Australia  
TEL: +61-3-9543-3720

## Americas

### USA: Delta Electronics (Americas) Ltd.

5101 Davis Drive, Research Triangle Park, NC 27709, U.S.A.  
TEL: +1-919-767-3813 / FAX: +1-919-767-3969

### Brazil: Delta Electronics Brazil

Rua Itapeva, 26 - 3º, andar Edifício Itapeva,  
One - Bela Vista 01332-000 - São Paulo - SP - Brazil  
TEL: +55-12-3932-2300 / FAX: +55-12-3932-237

### Mexico: Delta Electronics International Mexico S.A. de C.V.

Gustavo Baz No. 309 Edificio E PB 103  
Colonia La Loma, CP 54060  
Tlalnepantla, Estado de México  
TEL: +52-55-3603-9200

## EMEA

### EMEA Headquarters: Delta Electronics (Netherlands) B.V.

Sales: Sales.IA.EMEA@deltaww.com  
Marketing: Marketing.IA.EMEA@deltaww.com  
Technical Support: iatechnicalsupport@deltaww.com  
Customer Support: Customer-Support@deltaww.com  
Service: Service.IA.emea@deltaww.com  
TEL: +31(0)40 800 3900

### BENELUX: Delta Electronics (Netherlands) B.V.

Automotive Campus 260, 5708 JZ Helmond, The Netherlands  
Mail: Sales.IA.Benelux@deltaww.com  
TEL: +31(0)40 800 3900

### DACH: Delta Electronics (Netherlands) B.V.

Coesterweg 45, D-59494 Soest, Germany  
Mail: Sales.IA.DACH@deltaww.com  
TEL: +49(0)2921 987 0

### France: Delta Electronics (France) S.A.

ZI du bois Challand 2, 15 rue des Pyrénées,  
Lisses, 91090 Evry Cedex, France  
Mail: Sales.IA.FR@deltaww.com  
TEL: +33(0)1 69 77 82 60

### Iberia: Delta Electronics Solutions (Spain) S.L.U

Ctra. De Villaverde a Vallecas, 265 1º Dcha Ed.  
Hormigueras – P.I. de Vallecas 28031 Madrid  
TEL: +34(0)91 223 74 20

Carrer Llacuna 166, 08018 Barcelona, Spain

Mail: Sales.IA.Iberia@deltaww.com

### Italy: Delta Electronics (Italy) S.r.l.

Via Meda 2-22060 Novedrate(CO)  
Piazza Grazioli 18 00186 Roma Italy  
Mail: Sales.IA.Italy@deltaww.com  
TEL: +39 039 8900365

### Russia: Delta Energy System LLC

Vereyskaya Plaza II, office 112 Vereyskaya str.  
17 121357 Moscow Russia  
Mail: Sales.IA.RU@deltaww.com  
TEL: +7 495 644 3240

### Turkey: Delta Greentech Elektronik San. Ltd. Sti. (Turkey)

Şerifali Mah. Hendem Cad. Kule Sok. No:16-A  
34775 Ümraniye – İstanbul  
Mail: Sales.IA.Turkey@deltaww.com  
TEL: + 90 216 499 9910

### MEA: Eltek Dubai (Eltek MEA DMCC)

OFFICE 2504, 25th Floor, Saba Tower 1,  
Jumeirah Lakes Towers, Dubai, UAE  
Mail: Sales.IA.MEA@deltaww.com  
TEL: +971(0)4 2690148